

CEC NEWSLETTER

APRIL 27, 2001

IN THIS ISSUE:

Referral Bonuses

Show Emergency Backup

Top 20 Sales Volume

Worker's Comp Update

May 6 Coupon Promotion

Top 20 Sales Increase

REFERRAL BONUSES

Congratulations to the following individuals for their efforts with the Manager Referral Bonus Program ...

<u>Star Cast Member</u>	<u>Location</u>	<u>Referral</u>	<u>Bonus Amount</u>
RUTH DEVITT	645	ALISON DELANO	\$500.00
DAN HUNTER	512	SHAWN MIELKE	\$250.00
ABE ALABI	891	MARCUS STOUT	\$250.00
TINA YOUNG	652	SUSAN STANCIL	\$250.00
SHAWN BROWN	403	DEBRA WHITE	\$250.00
CARLOS DEPINTO	435	LOUIS VILSAINT	\$250.00
JAMES WHITE	033	JASON WILSON	\$250.00
JOE MONTEIRO	487	JIM RUBOYIANES	\$250.00
JASON SWEETMAN	117	BRYAN FISHBURNE	\$100.00
DAVID KITNER	611	DOREEN HODGE	\$50.00
JIM MILLIGAN	117	SEAN HENRY	\$50.00
YESY SALINAS	099	FREDY MORALES	\$50.00
VERNON WARD	380	CHUN RESKO	\$50.00

For information on how YOU TOO can earn a referral bonus, contact your Regional Recruiter or Raquel Sifuentes at (972) 258-5464. Thank you and **KEEP THOSE REFERRALS COMING!**

WORKERS' COMPENSATION DEPARTMENT UPDATE!

More hands to assist you in the management of any work-related injuries! The Workers' Compensation Department is excited in welcoming our new Senior Specialists, Shirl Wilson and Maria Vargas. Shirl officially joined CEC on February 12, 2001. Maria Vargas joined us shortly thereafter on March 21, 2001.

We will be splitting the handling of claims into East Coast and West Coast. This means your State will have a designated Specialist as your first contact on any work-related claim. The split is as follows:

EAST COAST – MARIA VARGAS

972-258-4225

AL, CT, DE, FL, GA, IN, KY, MA, MD, MI, MS, NC,
NH, NJ, NY, OH, PA, RI, SC, TN, VA, WI

WEST COAST – SHIRL WILSON

972-257-3062

AR, CA, CO, IA, ID, IL, KS, LA,
MN, MO, NE, NM, NV, OK, TX, WA

If you have any questions or concerns or just want to touch base with us, don't hesitate to contact us.....we're here to support you!

Mary Crane, Workers' Compensation Claims Manager --- 972-258-5474

SHOW EMERGENCY BACKUP

CEC Show and 3 Stage Show

In the event that your show VCR fails, the CEC Show and 3 Stage Show have an Emergency backup tape. The diagram below instructs you how to connect a Hi Fi Stereo VCR to play the 60 Minute Emergency Backup Tape (CEC Show Part # CS-0053-A, 3-Stage Show Part # CS-0053). It must be a Hi Fi Stereo VCR or this will not work.

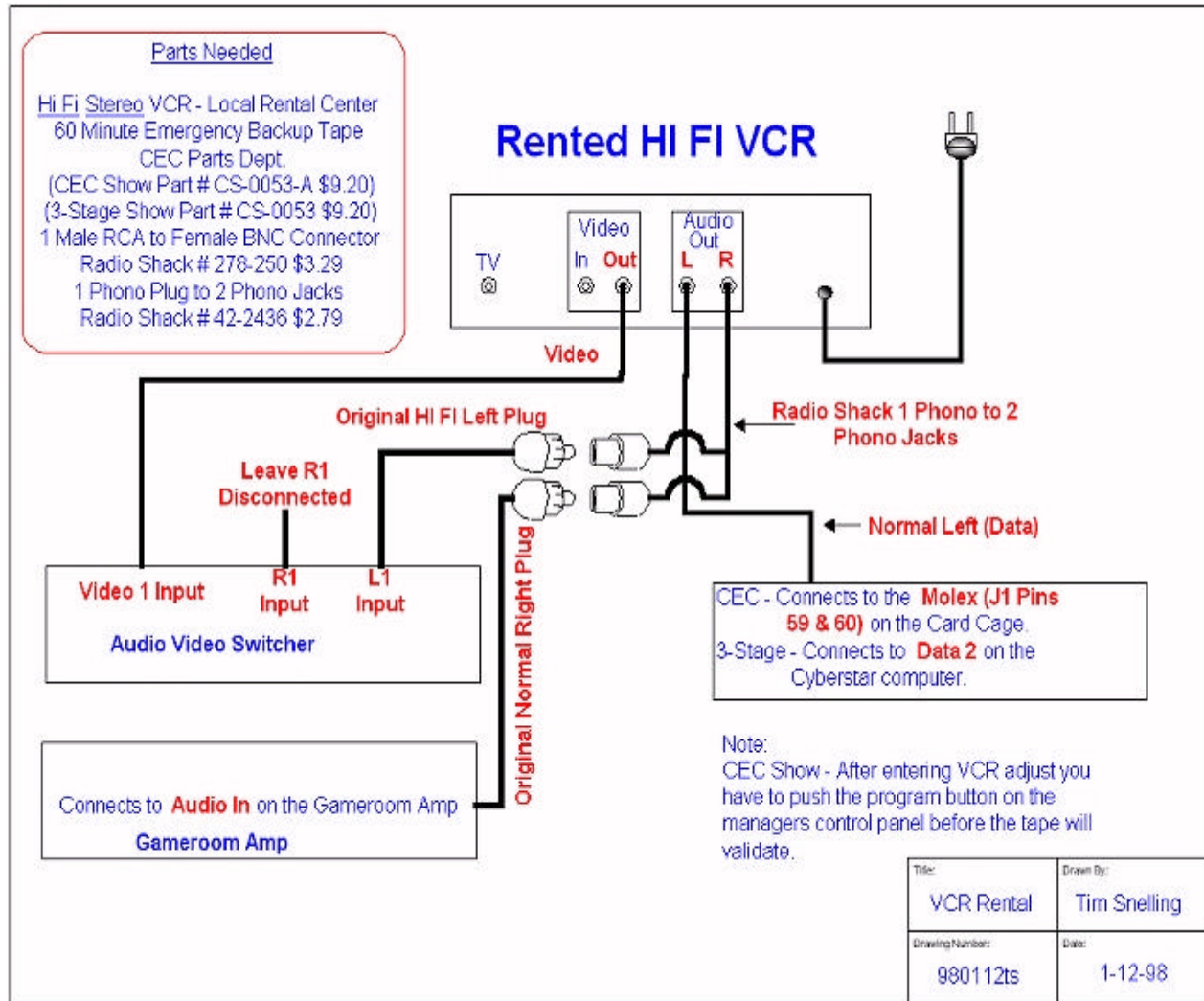

Studio C

Studio C has an emergency backup in the event of a hard drive failure. If your Studio C computer were to suffer a hard drive failure or you receive a message that informs you of a bad or missing file, it is still possible to run your show from your 3.5" floppy drive. All stores with Studio C should have the Emergency backup show that consists of Chuck E's Variety Show DVDs and a bootable floppy labeled Studio C Emergency Backup (part # STC-CRASH no charge, limited one per location).

If you do not have a backup for your show, you can order it from the CEC Parts Department (972) 258-5548. If you have any other questions, please contact CEC Technical support at (972) 258-5458.

MAY 6, 2001 COUPON PROMOTION

All markets will be participating in a coupon promotion in May. Coupons will be in newspapers 8n May 6. Below is a detailed list by market with coupon versions.

COUPONS:

- 1 large pizza with one or two toppings or Super Combo - 4 regular size soft drinks - 30 game and ride tokens! ONLY \$19.99 WITH COUPON	- 1 large pizza with one or two toppings or Super Combo - 4 regular size soft drinks - 48 game and ride tokens! ONLY \$22.99 WITH COUPON	- 1 large pizza with one or two toppings or Super Combo - 4 regular size soft drinks -75 game and ride tokens! ONLY \$25.99 WITH COUPON	- 1 large pizza with one or two toppings or Super Combo - 4 regular size soft drinks - 99 game and ride tokens! ONLY \$29.99 WITH COUPON
--	--	---	--

MARKETS:

Albany	D/FW	Lincoln	Roanoke
Albuquerque	Davenport	Little Rock	Rochester
Alexandria	Dayton/Springfield	Los Angeles	Rockford
Amarillo	Denver	Louisville	Sacramento
Atlanta	Des Moines	Lubbock	Salinas/Monterey
Augusta	Detroit	Madison	San Antonio
Austin	El Paso	McAllen-Brownsville, TX	San Diego
Bakersfield	Evansville	Memphis	San Francisco
Baltimore	Flint/Saginaw	Miami	Savannah
Biloxi-Gulfport, MS	Fresno/Visalia	Midland/Odessa	South Bend
Binghampton/Vestal	Ft. Smith/fYetteville	Milwaukee	Springfield, IL
Birmingham	Ft. Wayne	Minneapolis	Springfield, MA
Boise	Grand Rapids	Mobile/Pensacola	Springfield, MA
Boston	Greenville, SC	Montgomery	St. Louis
Buffalo	Hartford	Nashville	Tampa/St. Petersburg
Cedar Rapids	Houston	New York	Toledo
Charleston	Huntsville	Oklahoma City	Topeka
Charlotte	Indianapolis	Omaha	Tulsa
Chattanooga	Jacksonville	Orlando	Tyler/Longview
Chicago	Kansas City	Palm Springs	Washington DC
Cincy	Knoxville	Peoria	West Palm
Cleveland	Lacrosse	Philadelphia	Wichita Falls
Colorado Springs	Lafayette	Providence	Wichita, KS
Columbia, SC	Lansing	Raleigh/Durham	Wilkes-Barre/Scranton
Columbus, GA	Las Vegas	Reno	Youngstown/Boardman
Corpus Christi	Lexington	Richmond	

NOTE: NEW COUPON OFFER - ADD A MEDIUM PIZZA FOR ONLY \$7.99

SUPER FUN FAMILY PACK - 1 large pizza with one or two toppings or Super Combo - 4 regular size soft drinks - 30 game and ride tokens! ONLY \$19.99 WITH COUPON <i>Add a medium pizza for \$7.99</i>	CHUCK E.'s CHOICE - 1 large pizza with one or two toppings or Super Combo - 4 regular size soft drinks - 48 game and ride tokens! ONLY \$22.99 WITH COUPON <i>Add a medium pizza for \$7.99</i>	FUN MEAL DEAL - 1 large pizza with one or two toppings or Super Combo - 4 regular size soft drinks -75 game and ride tokens! ONLY \$25.99 WITH COUPON <i>Add a medium pizza for \$7.99</i>	ULTIMATE PLAY PACKAGE - 1 large pizza with one or two toppings or Super Combo - 4 regular size soft drinks - 99 game and ride tokens! ONLY \$29.99 WITH COUPON <i>Add a medium pizza for \$7.99</i>
--	--	---	--

MARKETS:

Baton Rouge	Greenbay	Harrisburg, PA	New Orleans
Columbus, OH			

Call POS if you have any questions about your registers. If you have questions after hours, call 817/870-0744. Please call Piper Shealy in marketing if you have any questions about the coupon promotion.

TOP 20 SALES VOLUME

<u>RANK</u>	<u>LOC #</u>	<u>LOCATION</u>	<u>SALES</u>	<u>RANK</u>	<u>LOC #</u>	<u>LOCATION</u>	<u>SALES</u>
1	446	Bell, CA	\$88,398	11	406	Huntington Beach, CA	\$63,724
2	841	Brookfield, WI	\$86,619	12	357	Lakewood, CA	\$63,379
3	321	Newark, CA	\$85,160	13	444	San Bruno, CA	\$61,671
4	418	Sun Valley, CA	\$77,800	14	058	Tinley Park, IL	\$60,074
5	453	Ventura, CA	\$72,387	15	517	Rochester, NY	\$59,980
6	324	Pasadena, CA	\$68,480	16	740	Canton, OH	\$59,978
7	456	Skokie, IL	\$67,282	17	325	Fullerton, CA	\$59,777
8	521	Vestal, NY	\$66,752	18	840	Amherst, NY	\$59,407
9	465	Torrance, CA	\$65,448	19	322	Dublin, CA	\$58,797
10	422	Garden Grove, CA	\$64,296	20	513	Queens, NY	\$58,592

TOP 20 SALES INCREASE

<u>RANK</u>	<u>LOC #</u>	<u>LOCATION</u>	<u>% INCREASE</u>	<u>RANK</u>	<u>LOC #</u>	<u>LOCATION</u>	<u>% INCREASE</u>
1	085	Rochester Hills, MI	97.8%	11	322	Dublin, CA	67.1%
2	713	Southgate, MI	95.9%	12	498	Cherry Hill, NJ	66.6%
3	103	Sterling Heights, MI	93.3%	13	716	New Orleans/Vet, LA	65.8%
4	399	Rohnert Park, CA	91.8%	14	323	Flint, MI	64.5%
5	954	Wilmington, DE	82.9%	15	715	Lafayette, LA	58.0%
6	559	North Olmsted, OH	77.8%	16	609	Baton Rouge, LA	57.9%
7	101	Parma, OH	72.5%	17	337	Pontiac, MI	57.5%
8	336	Saginaw, MI	71.5%	18	320	Thousand Oaks, CA	56.0%
9	058	Tinley Park, IL	71.1%	19	481	Deptford, NJ	54.0%
10	552	Boardman Park, OH	70.5%	20	414	Murrieta, CA	53.6%

CEC NEWSLETTER - APRIL 2001 ISSUES

(ONE ISSUE - 4/27/01)

Date of Origin: 2001
Archived: 5-30-12
Submission by Steve
Version 1.0

The documents contained herein are for educational use only.
Please do not replicate, redistribute, or make any unauthorized
printings. All intellectual property including characters,
artwork, photography, and slogans are trademark and/or
copyright their respective owners.

