

The New
Rock-afire Explosion®

User's Manual
and
Reference Guide

NEW-ROCK-A-FIRE EXPLOSION STAGE SHOW

MAINTENANCE

Routine maintenance on the show is more than important - it is absolutely necessary. The only difference between a well running show and a not-so-well running show is regular maintenance. As with any mechanical product, there will always be points of friction that require lubrication, and a small amount of normal wear that will affect certain adjustments.

For your convenience, the show is equipped with automatic oilers that handle the internal lubrication of all cylinders and air motors. There are only a few items on the show that require routine MANUAL lubrication: eyelids, eyes, turntable chains, and some character pivot points.

As for wear, with proper lubrication and adjustments, there should be a minimal amount. However, even a tiny amount of normal wear can affect the speed of character movements and turntables; hence, at the risk of sounding redundant, we cannot put enough emphasis on the importance of following the suggested schedules in this section.

DAILY, WEEKLY, and MONTHLY maintenance schedules appear on the following pages. It is suggested that you make plenty of photo copies of each schedule to use as checklists as the maintenance is performed. (Keep the originals in the manual for future copying.)

-- GO ON TO THE NEXT PAGE --

Dave/MBCSSA

THIS IS THE
MAINTENANCE MANUAL
FOR THE "SHOW" AS
DISCUSSED. PLEASE USE AS
NECESSARY.
Dave

-- DAILY --

- * Before turning on air, check all oilers and fill as needed with 10W non-detergent hydraulic oil.
- * Follow the start up procedure, then visually inspect all characters for proper stance as described in THE CHARACTERS section. Any movement that is not in its proper starting position at this point requires your attention to find out why. Fixing any small problems NOW will prevent damage.
- * Look at the eyes and eyelids of each character for signs of sticking or lack of lubrication, and lubricate as needed.
- * Visually check the arms and shoulder areas of the characters for costume pinching or pulling.
- * Visually inspect the stages and props for any abnormal wear or damage.
- * Listen carefully for air leaks in the characters or under the stage. Don't allow air leaks to go without repair - aside from affecting movements, there is a small amount of oil mixed with the air that will soil parts surrounding the leak.
- * Brush fur and blow off characters that don't look their best. Doing this every couple days, needed or not, will prevent the fur from matting and keep the costumes clean.
- * Play a couple shows, watch for obvious mechanical problems, and make sure the audio system sounds normal.

-- WEEKLY --

- * Drain water from compressor air tank. Drain water from drier.
- * Drain water from air filter next to the pressure regulator.
- * Turn the air on and follow the normal start up routine, check pressure gauge for 80 p.s.i., and adjust pressure regulator if necessary. Never vary from 80 p.s.i.!
- * Using override toggle switches, cycle curtain cylinders and check for proper operation. Watch for binding cables and/or loose or missing weights.
- * Look under each side turntable and note the oil level in the reservoir closest to the back of the stage. Then, using the toggle switches, rotate both side turntables and check the oil levels in the other two reservoirs (which are now closest to the back of the stage). If any of the four reservoirs has less than 1/4 inch of visible oil at any time, refer to SIDE TURNTABLES section for instructions. Check for oil leaks on the fittings and around the cables where they enter each end of the cylinder.
- * Thoroughly inspect each character for proper stance. Carefully note the position of the arms, head, and body. Check for any excess free movement. When in doubt, remove the costume to inspect suspicious "sloppiness" or "looseness" in any part of the character.
- * Lubricate eyes and eyelids using CEI eye lube ONLY. Remove any old lube first, using a soft cotton cloth. Do Not use paper towels or napkins.
- * Use the UTILITIES disk to check the speed settings of the large turntable and the three character (small) turntables. Tables that are too slow will affect the choreography and need to be adjusted ASAP. Tables that are too fast will cause damage and breakdowns, and MUST be adjusted NOW.

Adjustment guidelines:

Large turntable - 13.5 to 14.5 seconds; ideally, 14 seconds

Small turntable - 6.1 to 6.5 seconds; ideally, the fastest setting within the range that does NOT allow the turntable to coast into the stop mechanism. While making adjustments, watch the feedback gear to see if the stop-bolt is hitting the stop-pin at the end of the rotation in either direction. If it does, slow that direction down (a very small amount at a time) until the stop-bolt comes to rest just before the stop-pin. This will achieve the quickest, SAFE speed.

-- MONTHLY --

- * Use the AUTO ASSIGN FOR ADJUST feature of the UTILITIES disk to check the speed of each pneumatic movement of each character. Select the first movement on the list (Mitzi is used as the sampling list for this feature), then select 1.0 SECOND TIMER to cycle that movement on all the characters at the same time. This feature not only saves time, but allows you adjust the speed of the movement AND synchronize that movement on all the characters simultaneously. The guidelines for setting all the movement speeds are outlined in THE CHARACTERS section. As with the turntables, a movement that is too slow will affect the choreography and should be adjusted ASAP, but a movement that is too fast will surely cause damage and MUST be adjusted immediately. If a particular movement is suddenly much too fast, correct the speed, but be suspicious of a possible flow control problem and pay close attention to that movement over the next few days. If a movement is suddenly much too slow, check immediately for any physical binding or interference with the movement. Also, listen carefully for any air leaks while the movement is cycling. If there is no apparent reason for the slowness, correct the speed, but treat the condition as a possible flow control problem and watch it carefully for a few days to see if it reoccurs.

- * As above, use the AUTO ASSIGN FOR ADJUST feature to check the servo movements (eyes and eyelids) of each character. Servo speeds are not adjustable, but it is important to check them for smooth, uninhibited movement. A "sticky" eyelid or eye can damage the servo motor and/or the linkage. Check the eyes and eyelids for proper lubrication as described in the WEEKLY schedule.

- * Each character of the show should be internally inspected once every three months. Therefore, if your show has three characters, choose one for each month; if your show has six characters, select two for each month. This process does not take very long! Following these instructions will greatly reduce unusual wear, prevent internal damage, and significantly add to the lifetime of the character.
 - 1) Once each month, remove the entire costume and mask from the scheduled character(s).

 - 2) Literally start at the top of the head. Carefully inspect every visible part of the character all the way down to the feet. (If you disconnected the air to remove the costume, reconnect it now - it will make it easier to notice abnormal looseness in the character.)

3) Check for any loose screws, bolts, nuts, or shaft collars. REMEMBER: There are many bolt/locknut combinations acting as pivoting bolts throughout the character, and over-tightening them will hamper movement and possibly cause damage. When in doubt, refer to THE CHARACTER section for help in determining the difference! All hardware that is supposed to be tight should be checked (with tools) for tightness. All pivoting bolts should be just loose enough to spin freely, but should not have excess "end play" (defined in THE CHARACTER section).

4) After inspecting all the components of the character, expose the valve bank and manually actuate each movement at least a dozen times. The movement should be smooth and steady. There shouldn't be ANY binding or slamming.

5) If any part needs to be replaced, now is the best opportunity to replace it. If you don't have the required part on hand, order it right away. NOTE: If necessary, a movement can be temporarily stopped (while waiting for a new part) by closing the flow controls for that movement. You can avoid repair delays by keeping the spare parts kit stocked.

6) Make sure all clear plastic moldings are properly in place, then replace the mask and costume. With the character fully dressed, check the movement speeds one more time for correct adjustment.

*** CAUTION: Before performing the next few steps, disconnect the air line that feeds the large turntable air motor. Being under the center stage is safer with the air to the motor disconnected.

The next few steps require being under the center stage (the large turntable).

* Inspect the main harness that feeds the large turntable and the air lines/wire harnesses that are suspended below each cradle. Look for wear or cuts in the air hoses or protective cable sleeving. Worn or cut air hose should be replaced. Worn wire harnesses, if caught early enough, can be protected with new sleeving.

* Check the chains on the three character cradles for proper tension. (The diagram at the end of this section briefly describes the process of checking and/or adjusting chain tension.)

-- MONTHLY (cont.) --

- * Use a blow gun to clear away any dust on the four sets of infrared boards.
- * Check (for tightness) all bolts associated with the 6-inch wheels that support the center stage large turntable and the side stage turntables.
- * Inspect large air motor drive tire for wear. Remove any rubber tire particles with a vacuum. Replace the tire if necessary.
- * Check (for tightness) all 1/4-20 flat-head bolts that secure the diamond plate to the outside of the large turntable. At the same time, check the 1/4-20 flat-head bolts that secure the running boards (the curved plastic boards that ride on the 6-inch wheels) to the bottom side of the large turntable. If looseness is a problem, you can remove the bolt, lightly coat the threads with NON-permanent Loc-Tite thread sealer, and re-tighten the bolt in place.

- *** When you are finished under the stage, remember to reconnect the air line.

- * Perform routine maintenance on your air compressor as prescribed by its manufacturer.
- * Do general housekeeping, e.g., dust the props, vacuum the set, organize your spare parts area (re-order anything that you have used).
- * Finally, use a TOP QUALITY video tape head cleaner on your tape deck(s).

GENERAL DESCRIPTION

Background of the Rock-afire show

The first Rock-afire Explosion show was produced in 1980 and was placed in a Showbiz Pizza restaurant in Topeka, KS. This show was the first sophisticated animated show to appear in a restaurant. It was highly successful. People lined up outside the store in the dead of winter. From there the chain was expanded to over 220 restaurants. Creative Engineering, part owners of the concept, was in charge of the entertainment in the stores. The Classic Rock-afire grew in popularity and was an integral part of the burgeoning concept. People were amazed that their neighborhood entertainment center now contained Disney-like animation. Competition in this field quickly grew as more players entered the market. Along with the poor economy the concept fell on hard times and a washing out of the industry occurred. Showbiz bought the bankrupt Chuckie Cheese concept and proceeded to use the Chuckie characters exclusively. Creative Engineering proceeded to syndicate the Rock-afire Explosion to various concepts all over the world. Currently, there are Rock-afire shows on every continent except Antarctica. The Rock-afire show software is being translated into several different languages and is expected to add several more in the near future.

In 1992, the NEW Rock-afire Explosion show was introduced at the IAAPA show in Dallas TX. The next generation RAE show was designed to take the form to new heights. Through the use of Revolving turntables, video and customer interaction the RAE is poised to bring a whole new form of entertainment to parks and entertainment centers well into the 21st century. No longer are the characters screwed into one place. They are free to move from place to place on the stage, enabling them to interact with each other, the video screen and the audience. This allows entirely new forms of software to be performed. Educational software will be heavily explored. With the onset of such TV shows as Barney and Sesame St. it seems only natural for the New RAE show to perform a similar function. The show selector system, first developed for the Classic show is now available for the New RAE show with one major difference. No longer will the audience have to wait for a lengthy search. Once the thank you skit is finished the song selection will play instantaneously. With the use of video, spectators will be taken to various places around the world all narrated by members of the cast.

We expect about 6 new RAE shows to be in place by the end of 1994. From Minnesota to Mexico, the new RAE show will entertain and educate a new generation of children. It is our hope that with your help we can provide a service to your community and venture. We will make an effort to keep you posted on the progress and expansion of the new RAE show so that you will have a better understanding of this syndication effort and how it fits into your concept.

AUDIO / CONTROL RACK

Table of Contents

- General Description
- Start up / Shut Down
- Audio / Control Rack
- Computer / Wiring Diagrams
- Big Important Board
- DC Power Supply Circuits
- Operating System
- Show Adjustment Utilities
- The Characters
- Character Turntables
- Large Turntable
- Large Turntable Sync Problem?
- No Data To / From Turntables
- Side Turntables
- Props / Lights
- Maintenance
- Terms and Definitions

Odyssey Fun World

ODYSSEY FUN WORLD

- general description (4)
- start up / shut down (1)
- audio / control rack (2)
 - audio / control rack - with search deck
 - audio system - nrae with show selector
- computer / wiring diagrams (1)
 - wiring diagram - full show with show selector
- big important board (1)
 - big important board - standard
- dc power supply circuits (1)
 - bib power supply
 - main power distribution
 - large turntable interface board
 - limit switch circuit
- operating system (1)
- show adjustment utilities (2)
- the characters (10)
 - chart 2a - valve bank layout - billy bob - fatz - mitzi - beach bear - dook
 - chart 2b - valve bank layout - looney bird
 - diagram 2c - typical cylinder (cross-section view)
 - diagram 2d - typical rotary actuator
 - diagram 2e - pivot point example
- character turntables (6)
 - diagram 3a - fatz and mitzi front (utilities: position characters)
 - diagram 3b - cradle
- large turntable (5)
 - diagram 4a - fully clockwise position (#30 front-and-center)
 - diagram 4b - fully counterclockwise position
 - diagram 4c - beyond fully clockwise position, limit switch triggered
 - diagram 4d - beyond fully counterclockwise position, limit switch triggered
 - diagram 4e - #1 front-and-center
 - diagram 4f - large turntable feedback assembly
- large turntable sync problem ? (3)
- no data to / from turntables (1)
- side turntables (2)
- props / lights (2)
 - chart 6a - valve bank layout - props valve banks - left, center, and right stage
 - chart 6b - props controller
 - chart 6c - lighting controller
- maintenance (6)
 - chain adjustment tolerances
- terms and definitions (5)
 - appendix a

GENERAL DESCRIPTION

This introductory section is designed to take you on a quick tour of the show - from the VCR's and computer to the valve banks, air motors, lights, and props. The rest of the sections are devoted to specific areas of the show.

After following the start up procedure at the end of this section, the show is ready to play. In general, here's how all the computerized components of the show work:

The heart of the system is the computer (currently a modified Apple). The computer programs and cards do most of the decision-making while a show is running. For example, on a full show with Show Selector, the computer would do all the following: decide which song to play via the selector panels; instruct the appropriate VCR to play the show; decode the show data from the VCR video; send show data to the characters, turntables, and props; control time-outs between shows and the frequency of replays; and much more. In addition, in the utilities mode, the computer can perform dozens of diagnostic tests, manually cycle any movement of the show, and even send and receive e-mail with the optional modem. The computer is the central interpreter that synchronizes all the other components of the show.

All of the show information is contained on the video tapes - the video, the stereo audio, and the control data (encoded in the video). There are two VCR decks used for most shows. The first deck is a professional RS-232 controllable "search deck" (currently, a Panasonic). There are two key features of this deck, the first being the RS-232 connection between the deck and the RS-232 card in slot #4 of the computer. This connection gives the computer direct and complete control over the VCR deck. The other key feature is the internal counter that tracks the exact position of the tape and can be accessed by the computer, i.e., the computer tells the VCR to "go to" a particular spot on the tape (the beginning of the selected show), and the deck automatically rewinds or fast-forwards to that exact position. (A show with neither Show Selector nor Karaoke would not have this search deck.)

The second VCR deck is a commercial-grade deck with a standard remote control unit that has been wired to the Big Important Board (described later). For most shows, this deck is called the "thank you" deck because it's duty is to play a short skit before each actual show is played from the search deck. The thank you shorts are played back sequentially one at a time until the last one is played, at which point the tape is rewound to the beginning. The play, stop, and rewind commands come from the computer via the remote control. If it was possible to get a

quality commercial-grade deck with a remote jack on the back, we would certainly use it; however, the days of "wireless" remotes are here to stay, so no one makes a deck with a "wired" remote jack anymore. Just as you would with a home VCR, please keep the remote transmitter and the VCR's dust-free to ensure trouble-free operation. (A show with neither Show Selector nor Karaoke would ONLY have this deck.)

From the video decks, the video and audio travel different directions (refer to the wiring diagram in the COMPUTER / WIRING DIAGRAM section while reading the information below):

VIDEO SIGNALS:

The video from both decks goes into two input jacks on the Video Decoder card in slot #1 of the computer. The Decoder separates the show control data (described below) from the video itself. The video is then sent on to the Big Important Board (BIB). The BIB, according to the programming, amplifies the signal and controls when the signal is then allowed to be sent back out to the TV(s). (Shows with Karaoke work a bit differently - see the BIG IMPORTANT BOARD section and the wiring diagram.)

SHOW CONTROL DATA:

The show control data leaves the computer at two output jacks on the keyboard-end of the Showplay card in slot #2 of the computer. The top output is referred to as the "top drawer" signal, the bottom as the "bottom drawer" signal (a throwback to a much older version of a computer that was housed in a small gray cabinet that literally has two drawers). The top drawer signal goes directly to Dook's bit-stripper, then on to the Large Turntable Interface Board where it splits off to supply show data to Billy Bob's, Fatz's, and Mitzi's bit-strippers. The bottom drawer signal goes to the BIB which has its own bit-stripper on board to collect the specific data necessary to control the large turntable, character turntables, and strobe light. The signal then leaves the BIB and continues on to the panel box that houses the lighting and props bit-strippers. From there, the signal passes to Looney Bird's bit-stripper and on to Beach Bear's bit-stripper. (Lite shows do not have Dook, Looney Bird, or Beach Bear.)

BIT-STRIPPER - The bit-stripper system consists of several individual boards (mentioned above), each having a particular set of functions. Each character of the show has its own bit-stripper board. The props and lights each have a bit-stripper board as well. (The exception is the bit-stripper circuitry for the turntables and strobe light which is integrated on the BIB.) These bit-stripper boards are nearly identical except for the 6801 processor that is programmed to make each board specific to its task (the lighting board is slightly modified).

Character bit-stripper boards use the show data to shift the individual 24vdc valves of the valve bank that control all the pneumatic movements of the character. Character boards also have a 6805 PROM to control the 5vdc electric servo motors that operate the eyes and eyelids. The props bit-stripper board essentially works the same way by shifting the 24vdc pneumatic valves that control the curtain(s) and side turntable props (if equipped).

On each bit-stripper is a line of LED's that indicate when a movement is ON. When the LED is lit, the controlled movement is ON. The LED's, in order (starting near the edge of the board), represent the following:

- LED # 01-21 pneumatic movements associated with that bit-stripper, e.g., LED #1 on a character is the mouth.
- LED # 22-27 servo movements on characters
- LED # 28 not used
- LED # 29-30 connected in parallel, these two LED's indicate when the board is accurately interpreting the show data from the computer - a condition referred to as "in sync." When the LED's are NOT lit, the board is in sync. If the LED's ARE lit, the board is not in sync and will not operate properly.

The lighting bit-stripper board uses the show data to switch the 24vdc inputs on the solid-state relays to close the high voltage side of the relays to power the lights. On the lighting bit-stripper, the LED's #01-24 represent the first 24 solid-state relays in the lighting controller (described in PROPS / LIGHTS section). As with all bit-strippers, LED's 29-30 are for indicating sync.

AUDIO SIGNALS:

The stereo audio leaves the VCR's and goes directly to the BIB at four input jacks (two for each VCR). The BIB determines which deck is in play, and passes that audio (left and right channels) out the two output jacks to the equalizer. From there, the audio goes to the SPL computer (if equipped), then to the crossover device which separates the lows-frequency tones from the high-frequency tones. The "lows" go to the mixing amp that combines both channels to mono, and then on to the subwoofer amp that drives the bass speaker under the stage, behind the front grill. The "highs" go directly to the main amp that drives the eight monitor speakers placed around the room (see the audio system diagram).

ANIMATION:

The animated components are in, basically, three different groups: character movements, props, and turntables.

CHARACTER MOVEMENTS - The eyes and eyelids of each character are controlled by electric servo motors (servos), while all other movements are pneumatically operated. The pneumatic movements are all controlled by the valve bank mounted underneath or behind each character. The valves are shifted (energized/de-energized) by the bit-stripper board according to the show control data. For example, when the *right arm raise* valve is energized, the arm raises; when de-energized, the arm returns to its starting position. Most character movements are actuated by air cylinders that extend and retract, while others use rotary actuators that rotate up to 90 degrees.

PROPS - Props are all other pneumatic movements outside of the characters. These movements include (on a full show) rabbit ears, imitation speakers, coconut drop, Beach Bear's window, computer swivel, curtains, and side turntables. The reason side turntables are on this list is because they are moved by an air cylinder and are controlled by "props" valve banks; however, side turntables are discussed separately from the props in the manual sections due to their unique air-over-oil design.

TURNTABLES - The center stage has one large turntable on which the center-stage characters travel, and each center-stage character is on its own, smaller turntable. These four turntables operate essentially the same way - each is moved by an independent air motor, each can be moved independently of the others, and each has an independent "feedback" unit to tell the computer system its current position and its direction of travel (when moving).

**** The above general information is just that - general. ****

**** Detailed information follows in separate sections. ****

**** Do yourself a favor - read it! ****

**** Questions? Call 407-425-1001 ^{Thru 14} ****

ASK FOR ALEX

START UP / SHUT DOWN

START UP PROCEDURE FOR NEW ROCK-AFIRE SHOW

- 1) Turn on all circuit breakers for show
- 2) Turn on compressor system
- 3) Turn on sound system from top down (EQ then amps)
- 4) Turn on computer monitor
- 5) Be sure show selector disk is in the disk drive
- 6) Turn on computer
- 7) Turn on RCA VCR (Thank you deck)
- 8) To start show selector system, press button labeled-
PRESS THIS BUTTON WHEN SYSTEM IS TURNED ON
- 9) System will rewind and reset each VCR and turn on
panel lights
- 10) You are ready for operation

SHUT DOWN PROCEDURE FOR ROCK-AFIRE SHOW

- 1) Turn off computer
- 2) Turn off sound system bottom up (amps then EQ)
- 3) Turn off all circuit breakers
- 4) Turn off compressor system
- 5) System is shut down

AUDIO / CONTROL RACK

The items in the rack are shown in the diagram at the end of the section. Following that is another diagram that shows the audio path of the entire show. The following information is a shelf-by-shelf, general description of the components, along with some helpful hints.

MONITOR - The monitor is monochrome and is subject to screen burn-in, so you are encouraged to keep either the contrast or brightness control set to minimum when the monitor is not being utilized. Some program prompts require the lightpen for making selections; therefore, you will have to make sure the contrast and brightness controls are set high enough for the lightpen to work properly. (When you're all done, darken the screen again.)
NOTE: There is no audio signal sent to the monitor.

AUDIO AMPLIFIER - This is a low-power audio unit (make and model may vary) used to match the volume of the audio of the Thank You deck to that of the Search deck. Audio levels are carefully controlled during recording, but slight level differences may be experienced due to differences in the VCR's themselves.

DISK DRIVE - A high density (1.44 Meg) drive that uses specially formatted disks supplied by Creative Engineering, Inc.
CAUTION: Do not attempt to copy a C.E.I. disk on a standard PC - it won't work!

COMPUTER - (See the **COMPUTER / WIRING DIAGRAMS** section)

SEARCH DECK (VCR #1) - Professional-grade, addressable search deck that is controlled directly and completely by the computer via the RS-232 cable between them. This deck, which plays the show tape, can locate the exact beginning point of any show/song according to the indexing information on the accompanying show disk. (Shows with neither Show Selector nor Karaoke will not have this deck.)

THANK YOU DECK (VCR #2) - Commercial-grade VCR controlled by the wired remote control to play a "Thank You [for pressing a button on the Show Selector]" skit prior to each show. (On shows with neither Show Selector nor Karaoke, this will be the only deck in the rack and will not play "thank you" skits as it will contain the sequentially played shows.)

BIG IMPORTANT BOARD - (See **BIG IMPORTANT BOARD** section)

SPL COMPUTER (Sound Pressure Leveling) - If equipped with your show, its purpose is to automatically adjust the volume of the audio according to background noise. If the area directly immediate to the show experiences extreme fluctuations in background noise, an SPL computer can appropriately balance the audio level to the noise.

EQUALIZER - In most circumstances, the equalizer should be kept flat (all levels at zero). If, however, you have specific experience in adjusting tones, make adjustments conservatively. Remember: what sounds specifically "good" to one person may not sound good to the general public. When in doubt, set the EQ flat.

SUBWOOFER AMP - Used to control the lowest bass tones, this amp powers the woofer behind the grill on the front of the stage. CAUTION: Adding too much bass can cause "rumbling" that will ruin the quality of the audio. Get more than one person's opinion to help set the levels in your room.

MAIN AMP - Used to control the volume level of the eight room speaker.

POWER SUPPLY - This the main DC power supply of the show that supplies the power for the valve banks, the lighting relays, the Big Important Board (24vdc only), and the infrared feedback circuitry.

Audio / Control Rack

04/09/95

NOTE: Two items not visible from the front of the rack are the Yamaha PN90 Crossover and the Line Summing Amp. These two units are accessible from the rear of the rack.

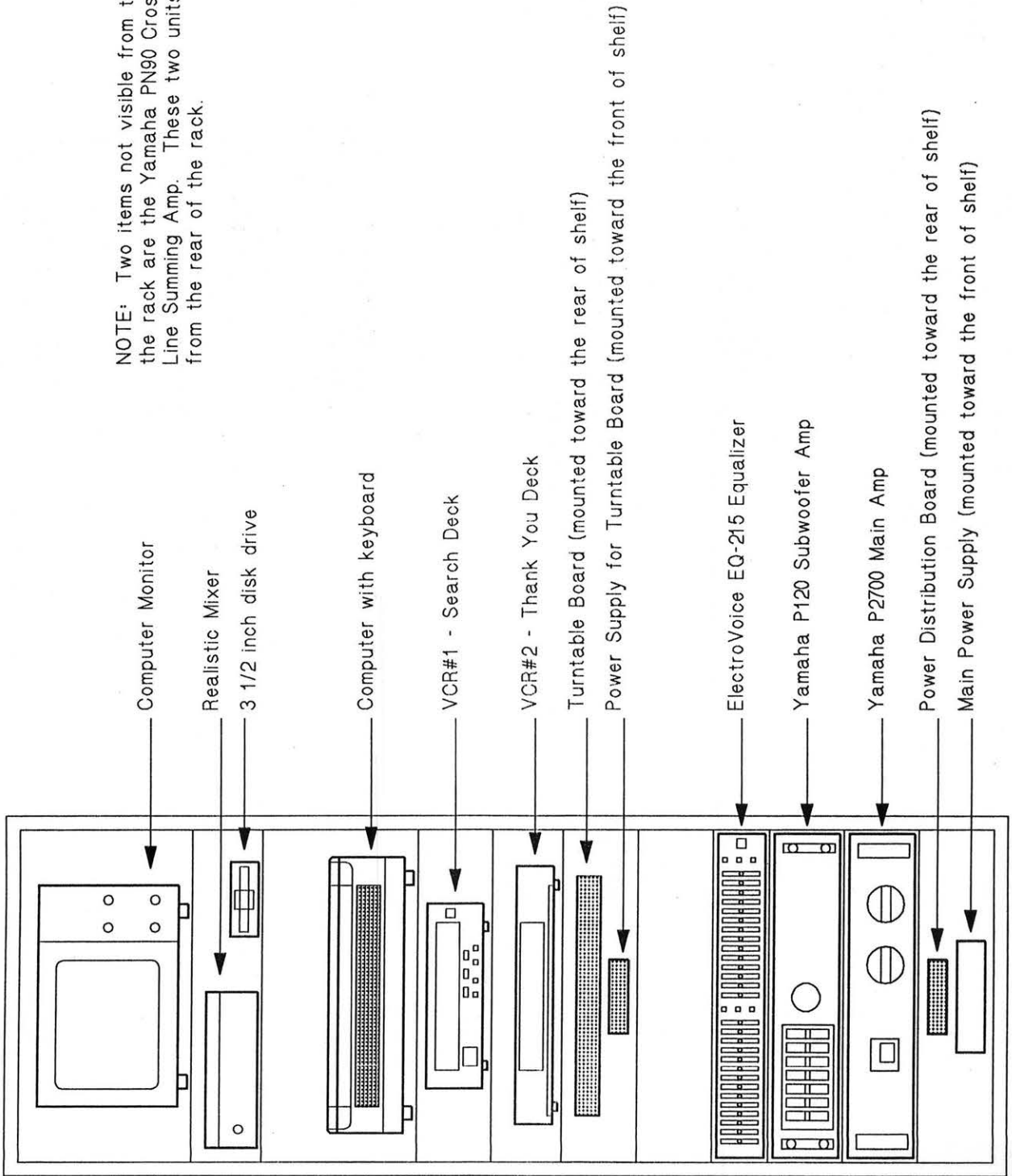

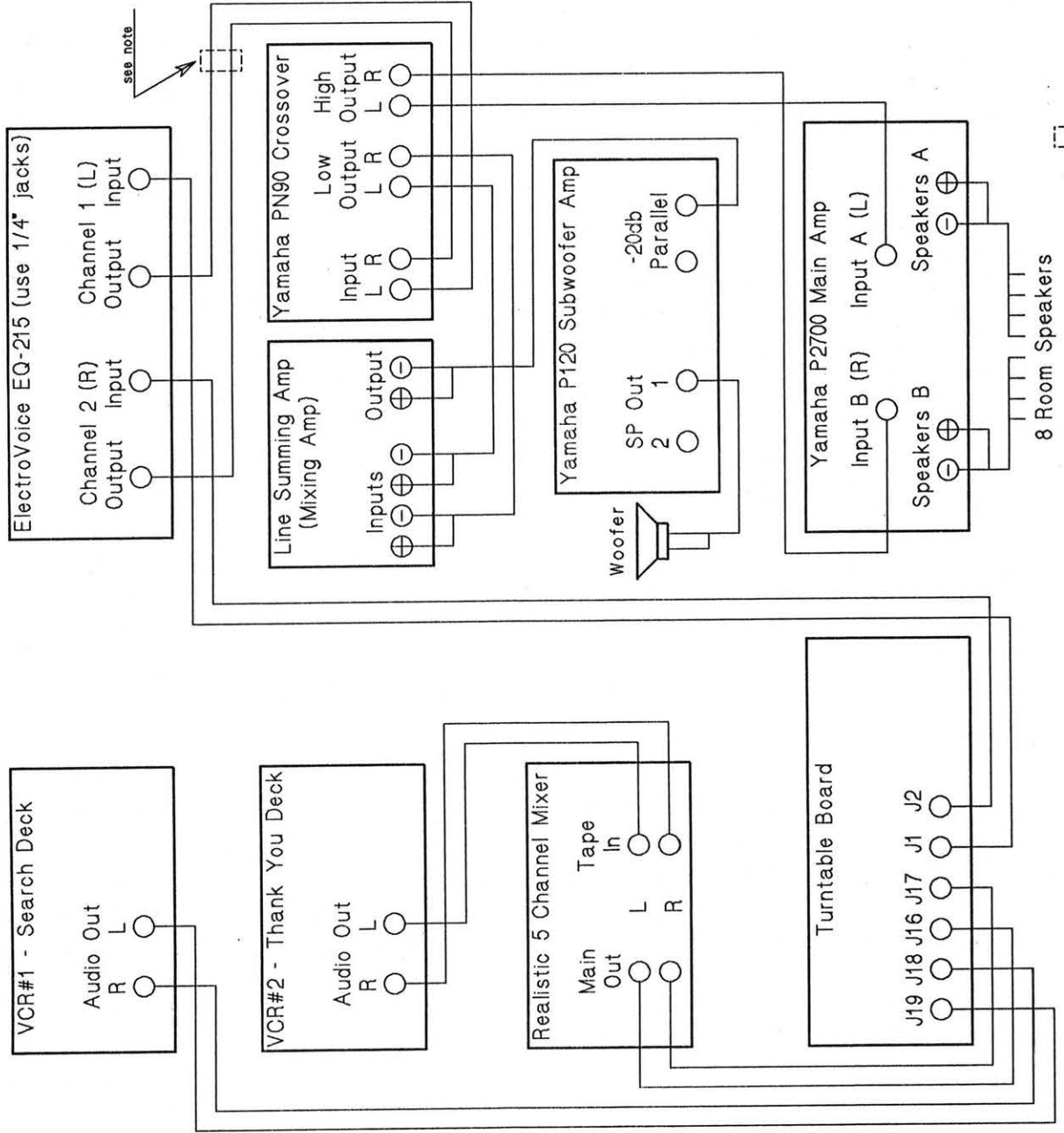

NOTE: If equipped, the SPL Computer goes in-line where indicated with []

THE COMPUTER

COMPUTER / WIRING DIAGRAMS

There isn't much else than can actually be "said" about the computer itself that hasn't already been outlined in the GENERAL DESCRIPTION section. The computer is an Apple II+ or IIe that has been modified to work with the custom-made cards (boards in the slots) manufactured by Creative Engineering, Inc.

On the following page is a wiring diagram that shows the connections between the computer cards (boards) and the other components of the show.

GENERAL NOTES:

- 1) Keep the Caps Lock on at all times.
- 2) Keep at least one foot clearance behind the rack that holds the computer (to prevent heat build-up).
- 3) Keeping the monitor screen clean will help the lightpen work efficiently.
- 4) Protect the disks and drive from dust, and, as usual, don't ever expose the floppy disk itself (protected by the sliding metal door on the plastic disk casing).
- 5) Keep the lid ON the computer at all times. Leaving the lid off is far too dangerous - anything falling into the interior of the computer could do serious damage.
- 6) The computer has its own internal power supply that should last a few years, depending on how long the computer is on each day. If you have to replace the power supply, use the spare in the spare parts kit and reorder another spare. Without the computer, the show will not run.

TURNTABLE BOARD

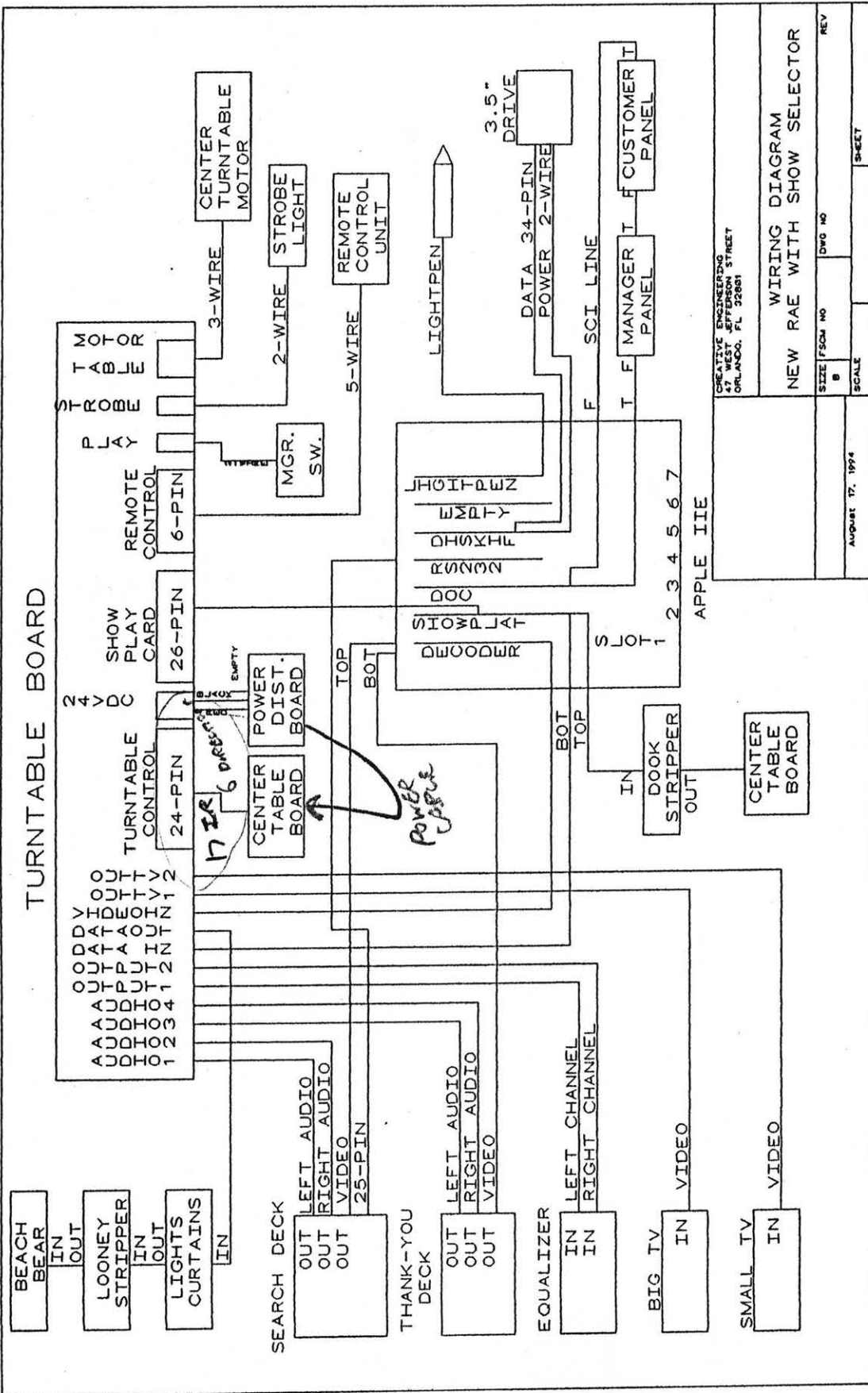

CREATIVE ENGINEERING
47 WEST JEFFERSON STREET
ORLANDO, FL 32801

WIRING DIAGRAM
NEW RAE WITH SHOW SELECTOR

AUGUST 17, 1994	SCALE	SHEET
SIZE FROM NO	DWG NO	REV

BIG IMPORTANT BOARD

BIG IMPORTANT BOARD

The Big Important Board (formerly known as the turntable board) is mounted on standoffs on a shelf in the audio rack, and is the most important (thus, the name) and most complex board in the entire system. The Big Important Board (BIB) and its connectors are shown in the diagram at the end of this section.

The BIB performs many functions, both on its own and in conjunction with the computer. These functions are:

1) Receives left and right audio channels from VCR(s) (jacks J19-J17), decides which is playing, and passes the audio out to the equalizer (jacks J1 & J2).

2) Collects show data from the computer's showplay card, sends it through the bit-stripper, and passes the signal on to the lights/props bit-strippers. The bit-stripper on the BIB strips out the showplay data necessary to control the large turntable, the three character turntables, and the strobe light.

3) Receives video signal from the computer's video decoder card, amplifies the signal, and sends it out to the large screen TV and Looney Bird TV (jacks J8-J10).

NOTE: For shows with Karaoke, jacks J8-J10 work differently. J8 receives the video signal, J10 receives the composite monitor signal from the computer, and J9 outputs whichever the BIB selects to the Karaoke TV.

4) Via the 24-pin connector, reads positioning information from the large turntable and character turntables, and controls the valves for the character turntable motors.

5) Operates the remote control for the commercial VCR.

NOTE: Your board may have an 8-pin connector for the remote instead of the original 6-pin as shown in diagrams. The other two pins supply the 5 volts that used to be picked up on the main power distribution board.

6) Receives Manager switch signal (if so equipped).

7) Controls the valve for the large turntable motor.

The power to the BIB is supplied by an independent power supply mounted on the same shelf and behind the BIB. There is a 6-pin jack on the BIB (J13) to accept the connector of the power supply. Looking at the BIB from behind the audio/control rack, the pin layout is shown in the diagram at the end of this section.

OPERATING SYSTEM

UTILITIES

THE CHARACTERS (ROBOTICS)

MECHANICAL TROUBLESHOOTING

CHARACTER TROUBLESHOOTING

As you will notice many of the parts of these characters are made of plastics. This has been done for many reasons, ease of replacement, lower costs and to reduce weight. This also means that we need to keep an eye on those parts a little closer to ensure proper wear. Due to friction all parts will wear at varying speeds. We use a lubriplate type grease on these parts. It is important that monthly we strip a character to ensure we don't have any excessive wear that could cause a failure and further damage.

Bolts that run through the joints should be well lubricated and should not have any excessive slop. When a figure is aired up and you lightly move the movement you should be able to feel any improper tolerances. If in doubt it is advised that the part be replaced to be safe. This determination at first seems difficult to make but once you become familiar with what is normal and what is abnormal it will be routine. Use white lubriplate grease when greasing a mechanical joint. Be sure to wipe off the old grease before applying more. You should not have an excess of grease oozing from the joints. Anytime you have a character apart you should take that opportunity to clean it inside. You will want to work on a clean character the next time you have to fix something.

Remember mechanical problems left unrepaired will surely lead to more costly artistic parts wear. If a mechanical part breaks it doesn't take long for the cosmetic parts above it to tear.

Air cylinders are well greased during assembly and should last for long periods without regreasing. On some occasions it may be necessary to grease a cylinder. Some cylinders are repairable and others are throwaways. Repairable cylinders are those working the arm raises, elbows, body tilts, knee bends, body turns. You should use CEI lube when rebuilding a cylinder.

VALVE BANK LAYOUT

VALVE #	MOVEMENT (ALL BUT LOONEY)	MOVEMENT (LOONEY ONLY)
1	MOUTH	MOUTH
2	LIP	LIP
3	HEAD UP	HEAD UP
4	HEAD TURN RIGHT	HEAD TURN RIGHT
5	HEAD TILT LEFT	HEAD TILT LEFT
6	RIGHT WRIST	RIGHT WRIST
7	RIGHT ELBOW	RIGHT ELBOW
8	RIGHT ARM TWIST	RIGHT ARM TWIST
9	RIGHT ARM RAISE	HEAD TILT RIGHT
10	RIGHT SHOULDER RAISE	RIGHT SHOULDER
11	LEFT WRIST	LEFT WRIST
12	LEFT ELBOW	LEFT ELBOW
13	LEFT ARM TWIST	LEFT ARM TWIST
14	LEFT ARM RAISE	BODY TURN RIGHT
15	LEFT SHOULDER RAISE	LEFT SHOULDER
16	HEAD TILT RIGHT	HEAD UP (WINDOW)
17	BODY TURN RIGHT	HEAD TURN (WINDOW)
18	BODY TILT LEFT	MOUTH (WINDOW)
19	BODY TILT RIGHT	LIP (WINDOW)
20	KNEES BEND	COMPUTER SWIVEL
21	EARS (DOOK AND MITZI)	

CHARACTER TURNTABLES

Each of the three center stage characters (Billy Bob, Mitzi, and Fatz) are attached to a small turntable, which allows each character to be independently positioned to face any direction at any time, regardless of the large turntable's position.

The character, the valve bank, and the bit-stripper are mounted in a wooden drum that is in turn mounted to a heavy-duty, hollow steel shaft. The shaft runs through an aluminum support mechanism called the "cradle," which is the three-inch square base with two vertical sides that attach it to the large turntable. Each character requires an air line to the valve bank, a power distribution cable to the bit-stripper, and a data cable to the bit-stripper. These three items come up through the hollow shaft into the drum, where they are held in place by strain-reliefs.

Under the cradle, on the lower end of the shaft, are two sprockets. The larger sprocket is attached by chain to the air motor that turns the character. The smaller sprocket is attached by chain in the other direction to a very large sprocket known as the "feedback gear." When the motor spins the turntable, the feedback gear is turned accordingly. The feedback gear has many sets of holes that, as it turns, pass between two circuit boards. Mounted on one board are infrared light emitters; mounted on the other board are infrared collectors. With everything properly aligned, the holes pass directly between the emitters and collectors. There are 15 unique combinations of holes that translate to 15 different turntable positions. Consequently, by monitoring the infrared boards, the computer knows where the turntable is and, when turning, which direction it is traveling, and when to stop.

These sprockets are preset at the factory and, aside from checking the chain tension (as described in the MAINTENANCE section), should never need adjustment. However, there are a number of areas of concern that should be fully understood by the store technician. The diagrams after this section will help clarify the following information regarding the character positions and the travel "limits" of the small turntables.

NOTE: With the exception of which direction each character faces relative to the large turntable, all three small turntables are mechanically identical by design and in operation.

CHARACTER POSITIONS:

The simplest way to understand the relationship of the small turntable positions is to put all three small tables AND the large table in their center positions. To do this, choose a time when the store is closed and then continue by doing the following: Turn off the computer. Remove the show disk, insert the UTILITIES disk, and turn the computer back on. At the main menu, choose POSITION CHARACTERS IN FRONT. Press number 4 which is FATZ AND MITZI FRONT. As shown in diagram 3A, this will position Fatz and Mitzi toward the front of the stage, and Billy Bob at the rear of the stage, directly in front of the big white circle on the back wall. At the same time, the small turntables have been positioned so that all three characters are facing directly forward. All four tables are now in their "center" positions. The center position for a small table is exactly half way between the fully clockwise extreme of the table and the fully counterclockwise extreme. (The center position of the large turntable is Billy Bob to the back of the stage, roughly centered between left and right.) A small turntable, from extreme counterclockwise to extreme clockwise, rotates slightly more than one and one-half revolutions (about 550 degrees). Consequently, when a small table is at its center position, the table can be turned three-quarters of a revolution in either direction before hitting a mechanical stop mechanism that prevents the table from going any farther. (For more information on positions, see the UTILITIES section.)

Whenever the computer sends a small turntable to a new position, it knows that there will be a small amount of drift (coasting) after the air motor is shut off; consequently, the motor is shut off a fraction of a second early to allow the turntable to coast to a stop, at or very near the desired position. As you can imagine, if the turntable speed (as defined under the UTILITIES section) is too fast, it will coast much too far and go beyond the target position; too slow, and the table won't even reach the target position. It's your responsibility, as with the large turntable, to check the small turntable speeds regularly.

THE LIMITS - SMALL TURNTABLE STOP MECHANISM:

ABOUT THE STOP MECHANISM - As mentioned above, each small turntable has a mechanical stop mechanism that prevents the table from turning too far in either direction. Mounted on the side of the cradle above the feedback gear is an "L" shaped aluminum bracket (see Diagram 3B). Bolted to the bracket is a heavy-duty steel pin that extends straight down next to the hub of the feedback gear. On the hub of the feedback gear itself, there is a bolt (with an aluminum spacer and lock washer) tightly screwed into and extending from the hub. When a character is turned to either extreme position, the bolt contacts the steel pin, which stops the table from turning any farther. The bolt and pin are very strong but NOT unbreakable. If the turntable is traveling

too fast, it will coast considerably more than it should and will result in the bolt hitting the pin with enough force to break the bolt, the pin, or both. Keeping the small turntables properly adjusted will prevent any breakage.

BROKEN STOP - If any part of the stop mechanism is broken, you should stop the show as soon as possible to avoid any further damage, and administer repairs. Before doing repairs, you will have to determine if the character is still in sync ("sync" is short for synchronization), and determine what caused the table to hit the stop so hard. But first, a little about "sync."

ABOUT SYNCHRONIZATION (SYNC):

There is a direct relationship between the small turntable and the feedback gear. The exact position of the turntable is determined by the exact position of the feedback gear. When the turntable and the feedback gear are in perfect sync, the position information sent to the Big Important Board is correct. As a result, when the Big Important Board "thinks" the table is at (for instance) its center position, the table actually IS at its center position. If, however, the table and feedback gear get OUT of sync, the feedback gear will continue to send position information to the Big Important Board, but the ACTUAL position of the table will be altogether different and unpredictable.

HOW DOES IT HAPPEN?:

There is only ONE way for the large table to get out of sync. The table must travel too far in either direction (go past the extreme clockwise or extreme counterclockwise position), which can only occur if the stop-bolt or stop-pin is broken. This can happen if the turntable speed is too fast and slams into the stop, or if a person manually spins the turntable (too fast/too hard) until it hits the stop, causing breakage. Regardless of how it happens, if the table spins PAST the normal stop point (in either direction), the circuit boards that straddle the feedback gear will begin reading holes that don't correctly correspond to the character's position. At this point, if a show is run, the turntable will likely turn, BUT the table and the feedback gear are no longer in sync.

To go into greater detail, the gear on the hollow steel shaft and the feedback gear have different numbers of teeth. The feedback gear is larger (60 teeth) than the hollow-shaft gear (36 teeth). Consequently, the two gears do not have a 1-to-1 ratio. The actual ratio is 5-to-3 to allow the turntable to travel about 190 degrees MORE than one complete revolution while the feedback gear makes LESS than one revolution.

If the small turntable goes past a normal stop point, the table and gear will be OUT of sync by 72 degrees OR MORE. So, the characters will always be facing the wrong direction. EVEN WORSE, the two wires that go up through the hollow shaft to the bit-stripper board will get twisted far beyond normal and could break. If the table is out of sync, stop the show immediately and do the following:

Step 1) SAFETY FIRST:

Disconnect the air line that feeds the large turntable air motor. Disconnect the air line that feeds the character air motors. You will need to get under the large turntable for inspection and repairs, and certain corrective measures might cause the tables to move suddenly if air pressure is still applied to the air motors.

Step 2) MOVING THE LARGE TURNTABLE:

Manually position the large table so that the character that needs work is next to a spot where you can get under the stage.

CAUTION: Be absolutely certain that you are turning the large turntable the right direction. You must not allow the table to contact the limit switch. If you are unfamiliar with the large turntable operation and its "limit" switch, read the LARGE TURNTABLE section before going any farther.

Step 3) INSPECTION:

Look carefully at the wires that go up through the hollow shaft. These wires are secured to the end of the cradle and are originally set to have a lot of slack (droop) between the end of the cradle and the hollow shaft (basically along side the air line). If the wires appear to be excessively twisted (compared to the other characters), make a note of which direction they are twisted, as you will NOT want to spin the character any further in that direction.

Step 4) VERIFYING THE SYNC:

Your small turntables should have center marks (as described in the UTILITIES section). The goal is to align the turntable center mark with the one on the stage, then check to see if the feedback gear is reading "center" as well. Simply rotate the table one way or the other (watch the wires) until the center marks align. Next, turn off the computer, insert the UTILITIES disk, and turn the computer back on. At the main menu choose READ TURNTABLE L.E.D'S. On the next screen, locate the name of the character you are working on and note the number next to it.

The range of possible numbers is 0 to 15. Numbers 0 through 14 (on the computer screen) correspond to the 15 readable turntable positions. Number 15 (on the screen) indicates that the infrared readers are between holes. The center position of a character is 7. If your character's center marks are aligned and the readout is 7, the turntable is in sync - skip down to Step 5. If the readout is not 7, read OUT OF SYNC below.

OUT OF SYNC - If the center marks are aligned and the readout is not 7, you must rotate the table one complete turn until the center marks align once again. The only criteria for determining which direction to turn the table is the amount of twist in the wires. Choose the direction that is more friendly to the wires, then go ahead with rotating the table one complete revolution.

Note: While you are turning the table, have someone watch the readout to make sure the numbers are changing as the table spins. This ensures that the signals from the infrared boards are reaching the Big Important Board. If the numbers don't change while the table is moving, go to the NO DATA TO / FROM TURNTABLES section now.

After rotating the table one turn and aligning the center marks again, check the readout for 7. If the readout is 7, skip down to Step 5. If the readout is not 7, you will need to repeat this process of turning the table one complete revolution at a time (in the SAME direction) until the readout is 7. In any event, the maximum number of revolutions to put the table back in perfect sync is four revolutions. When the center marks are aligned and the readout is 7, go to Step 5.

Step 5) BACK IN SYNC:

Now that the turntable is back in sync, you need to repair the stop mechanism before the table is turned any more. If the stop-pin broke, simply mark where the old pin is tightened in the bracket's slot, and replace it with the new pin. If the stop-bolt broke, locate the stop-bolt hole (which is now at its farthest point away from the pin, meaning, it is on the other side of the cradle from the stop-pin). Remember, the hole you are looking for is 180 degrees away from the stop-pin, NOT the hole that is roughly 90 degrees away. When you've located the hole, you will need to remove the broken-off end of the bolt still in the hole, using either needle-nose pliers or, if necessary, an Easy Out tool. Replace the bolt/washer/spacer combination EXACTLY as it originally was, using a 5/16-24 x 3/4 inch socket head cap screw, a "high collar" lock washer, and the 1/4 inch aluminum spacer. When properly replaced, the end of the bolt should contact the pin, but NOT hit the upper infrared board as it passes by.

Step 6) FINAL CHECK:

If you haven't already done so, read the UTILITIES section in order to fully understand references to numbered positions of the small turntable.

- A) Align the center marks one more time and check the readout for number 7.
- B) Rotate the table clockwise to the position 14 mark, then continue turning slowly and note how far past the mark the table goes before stopping.
- C) Rotate the table fully counterclockwise to the position 0 mark, then continue turning slowly and note how far past the mark the table goes before stopping.
- D) The amount of travel between the mark and the stop is end zone. Both end zones should be the same distance, give-or-take a half inch. If one end zone is longer than the other, you will need to adjust the stop-pin by loosening it, sliding it in the adjustment slot of the bracket, and retightening the pin. (You'll probably need to hold the pin with a pair of ViseGrips to keep it from turning.)
- E) When the end zones are equal, the table is ready.

Step 7) PUTTING THINGS BACK:

Reconnect the air line to the large turntable air motor and the air line to the character air motors. Go back to the main menu on the computer, choose POSITION CHARACTERS IN FRONT, and press number 4 which is FATZ AND MITZI FRONT. Compare to diagram 3A. If everything is correct, remove the UTILITIES disk, and turn off the computer.

Step 8) RUNNING THE SHOW:

Follow the normal procedures for starting up the system, and run a show.

DIAGRAM 3A

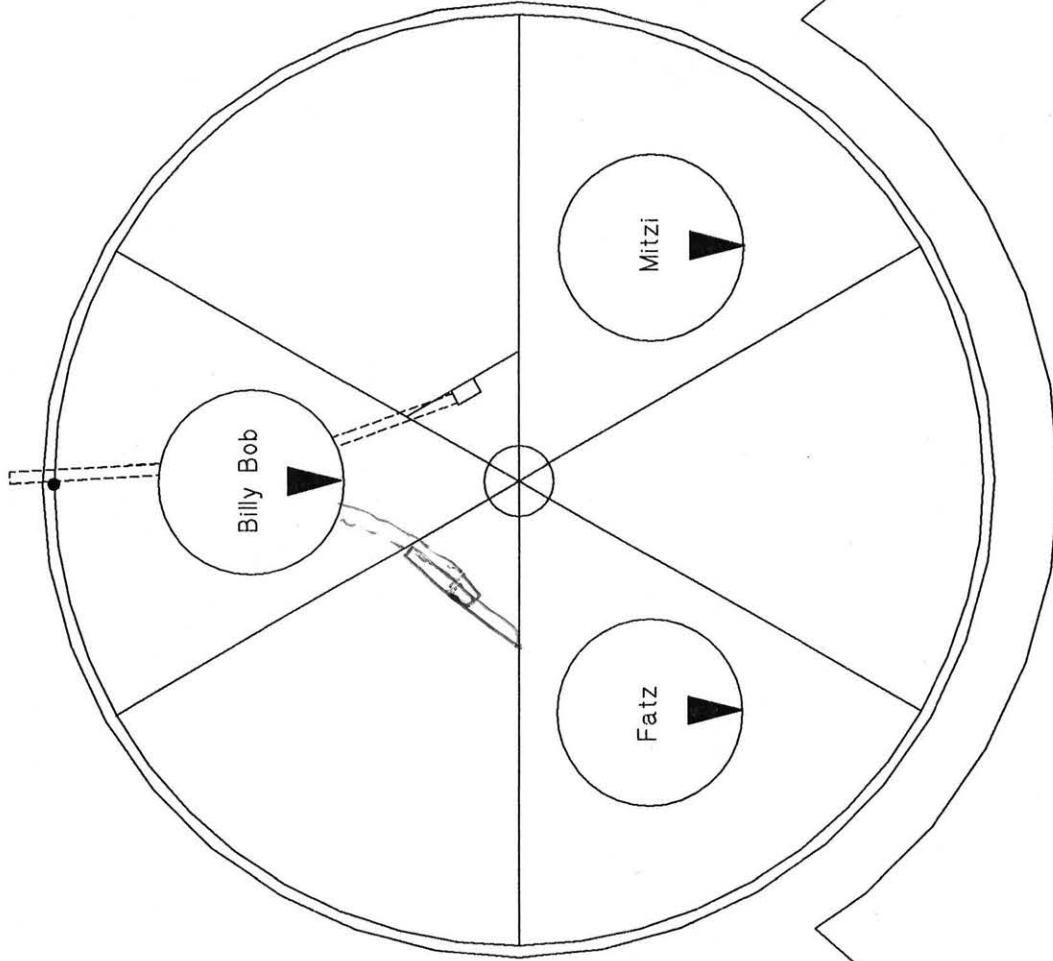

Large turntable CENTER position

Billy Bob is REAR and center.

All characters facing forward

Note: This position is # 16

Title: Fatz and Mitzi front (Utilities: Position Characters)

Date: 05/04/95 Scale: Representational

Tolerance (unless indicated):

Creative Engineering, Inc.
47 West Jefferson Street
Orlando, Florida 32801

DIAGRAM 3B

NOTE: For clarity purposes, the chains, wires, and hoses are not shown in this drawing.

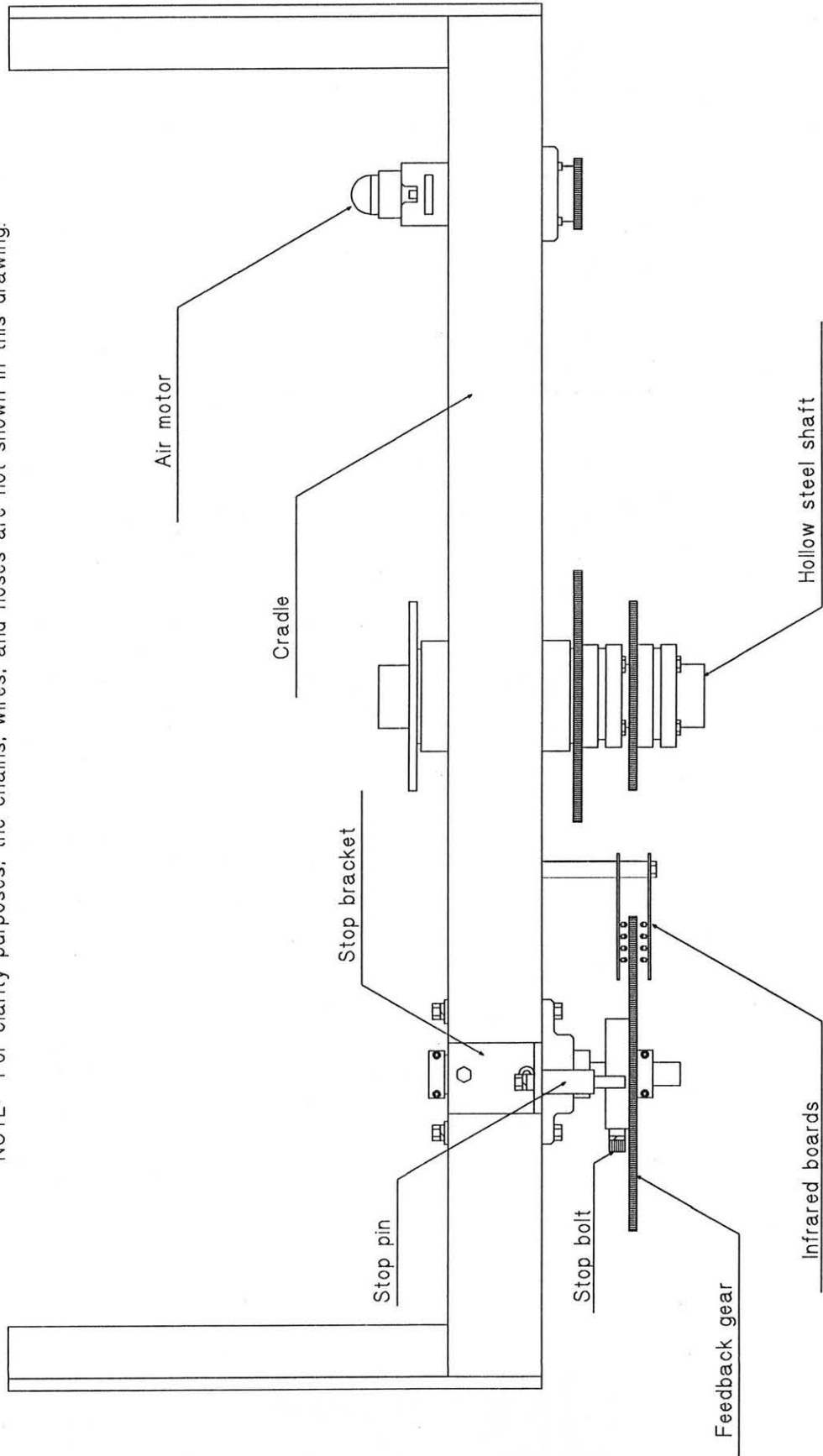

Title: Cradle

Date: 05/08/95

Tolerance (unless indicated):

Scale: 1/5 (approximate)

Creative Engineering, Inc.
47 West Jefferson Street
Orlando, Florida 32801

LARGE TURNTABLE

The large turntable (center stage) functions similarly to the character turntables, yet on a much larger scale. The turntable carries the three center stage characters - Billy Bob, Fatz, and Mitzi. Suspended beneath the turntable midway between Billy Bob and Mitzi is the main harness that provides air and electrical power to the turning table. This harness is shown in dashed lines in the diagrams that follow this section.

The table is turned by a large air motor located on the back of the stage. Mounted to the air motor shaft is a drive wheel and tire that runs on diamond plate attached to the perimeter of the turntable. To keep the tire from slipping on the diamond plate, there is an air cylinder that presses the motor/tire assembly against the diamond plate. There is a small, adjustable pressure regulator with a gauge attached to the cylinder itself. The pressure gauge should read 40 to 50 p.s.i. when the show is running.

Under the center of the turntable is the steel pedestal that supports much of the table's weight and houses the main shaft and bearings on which the table spins. On the pedestal is a small sprocket. Mounted on one of the spokes of the turntable is a shaft with a larger sprocket known as the feedback gear. The two sprockets are attached by chain. When the turntable spins, the feedback gear is turned accordingly. The feedback gear has many sets of holes that, as it turns, pass between two circuit boards. Mounted on one board are infrared light emitters; mounted on the other board are infrared collectors. With everything properly aligned, the holes pass directly between the emitters and collectors. There are 31 unique combinations of holes that translate to 31 different turntable positions. Consequently, by monitoring the infrared boards, the computer knows where the turntable is and, when turning, which direction it is traveling, and when to stop.

These sprockets are preset at the factory and should never need adjustment; however, there are a couple areas of concern that should be fully understood by the store technician. The diagrams after this section will help clarify the following information regarding the travel "limits" of the large turntable.

As shown in diagram 4A, when the computer sends the table fully clockwise, Billy Bob is front-and-center. As shown in diagram 4B, when the table is sent fully counterclockwise, Billy Bob travels beyond the front-and-center position and ends up closer to the big screen TV. During a show, whenever the computer sends the table to a new position, it knows that there will be a certain amount of drift (coasting) after the air motor is shut off; consequently, the motor is shut off a fraction of a second

early to allow the turntable to coast to a stop, at or very near the desired position. As you can imagine, if the turntable speed (as defined under the UTILITIES section) is too fast, it will coast much too far and go beyond the target position; too slow, and the table won't even reach the target position. It's your responsibility, as with the character turntables, to check the large turntable speed regularly.

IMPORTANT: The large turntable DOES NOT have a mechanical stop mechanism to prevent the table from going beyond the extreme clockwise position or extreme counterclockwise position. Instead the table is equipped with a limit switch that, when triggered, immediately shuts off all air to the large turntable motor and temporarily "kills" the large table, meaning it will no longer move at all on its own. This limit switch is mounted on the aluminum stage spoke next to the feedback gear shaft. There is a pin extending from the feedback gear shaft that comes in contact with the limit switch if the table travels too far in either direction. IF the table is traveling too fast and/or, for any other reason, the table travels too far in either direction, the limit switch will be triggered and the air motor shut down. In such event, it is critically important that the following procedures be used to correct the situation:

Step 1) QUALIFIED PEOPLE ONLY:

DO NOT allow any unqualified person to touch the turntable, e.g., a customer or employee that thinks giving the stage a "push" will fix the problem. In all likelihood, the problem will be compounded instead of cured. Please make sure that there is a "hands off" policy in place for this unlikely event.

Step 2) SAFETY FIRST:

Turn off the computer. This will prevent shows from running while you are seeing to the needs of the large turntable.

CAUTION: Do not get under the stage during any procedure in this section.

Step 3) DETERMINING THE DIRECTION OF TRAVEL:

YOU MUST determine which direction the table was traveling when the limit switch was impacted. This is done by noting two factors. First, where is Billy Bob located and, second, which way is the main harness wrapped around the pedestal? These can be easily determined by comparing your stage to the diagrams 4C and 4D. Diagram 4C shows the approximate positions of Billy Bob and the harness if the table traveled too far clockwise. Diagram 4D shows the approximate positions when the table travels too far counterclockwise. DO NOT rely on Billy Bob's position alone.

ALWAYS check the position of the main harness too, as it will ALWAYS TELL THE TRUTH. (NOTE: If the positions of your Billy Bob and the main harness DON'T resemble one of the two diagrams (4C and 4D), proceed directly to the next section entitled "LARGE TURNTABLE SYNC PROBLEM ?").

Step 4) MOVING TURNTABLE AWAY FROM LIMIT SWITCH:

TOO FAR CLOCKWISE - If the turntable has gone too far clockwise, push the turntable counterclockwise until Billy Bob is front-and-center and the harness is lying as shown in diagram 4A. This puts the table into the normal operating area and moves the pin off of the limit switch, returning air pressure to the motor. Read the CAUTION's below and go on to Step 5.

TOO FAR COUNTERCLOCKWISE - If the turntable has gone too far counterclockwise, push the turntable clockwise until Billy Bob is front-and-center and the harness is lying as shown in diagram 4E. This puts the table into the normal operating area and resets the limit switch, returning air pressure to the motor. Read the CAUTION's below and go on to Step 5.

CAUTION: DO NOT run a show after manually pushing the large turntable without first completing this section.

CAUTION: If the stage is manually pushed too far in the WRONG direction in error, the pin that contacts the limit switch will eventually go completely PAST the limit switch, allowing the switch to reset which restores air pressure to the motor. If this happens, the relationship between the turntable and the feedback gear (which tells the computer where the table is) is now completely out of sync. ("sync" is short for synchronization.) When the show runs, the large table will likely turn, BUT the characters will always be facing in a direction they shouldn't be. Another problem, even more important, is that the main harness can get wrapped MORE than once around the pedestal - a situation that can cause SEVERE damage to the harness and turntable (see LARGE TURNTABLE SYNC PROBLEM ?).

Step 5) PRESSING THE RESET BUTTON:

When the RESET button is pressed, the Big Important Board instructs the large turntable to turn counterclockwise until it finds the first set of readable holes on the feedback gear (the character turntables will be resetting at the same time). Under normal circumstances, the table will only have to move less than 10 inches before finding the next set of holes, taking less than 1 second of time. The turntable will stop turning, the system will be properly "reset," and you're ready for Step 6.

NOTE 1 - However, if the turntable travels more than about 3 feet counterclockwise without the infrared boards detecting a set of holes, which is unusual, the table will reverse and begin turning clockwise BACK toward the original position, searching the area again for a set of holes. If the search is successful, the table will stop before even getting back to the original position. When the holes are located, the table will stop turning, the system will be properly "reset," and you're ready for Step 6.

NOTE 2 - Though very unlikely, IF the turntable searches counterclockwise and then resorts to clockwise (as described above) and STILL fails to read a set of holes, the table will stop near too, or even PAST, the original position, which is much too far to travel without finding any holes, and indicates a problem. The turntable will stop turning altogether and the Big Important Board will go into a 20-40 second time-out. At the end of the 20-40 seconds, the Big Important Board will try again. It will automatically start the entire search process over, the equivalent of pressing the RESET button again.

Step 6) IS THE TURNTABLE RESET OR IS IT WAITING TO TRY AGAIN?

After the turntable stops moving, simply wait to see if the Big Important Board starts to search again within 40 seconds. If the table does NOT start moving again, skip down to CHECKING RESULTS. If the table DOES start moving again, read SEARCHING AGAIN below.

SEARCHING AGAIN - If the table begins moving again, wait for it to complete its 2nd attempt to find readable holes and comes to a complete stop. Again, WAIT 40 seconds to see if it starts a 3rd search. If the table does NOT start moving again, skip down to CHECKING RESULTS. If it starts a THIRD search, there is something wrong and you will need to intervene to stop the process. To avoid getting stuck in this "loop," shut down the ENTIRE system. As long as Billy Bob was properly positioned front-and-center prior to pressing the RESET button, there is only one logical explanation for endless searching - the signals from the infrared boards are not reaching the Big Important Board. Go to the NO DATA TO / FROM TURNTABLES section.

CHECKING RESULTS - If 40 seconds passes without the table moving again by itself, it is probably reset. PLEASE, don't run a show just yet. First, check the turntable positions by doing the following: Turn off the computer (actually, it should already be off). Insert the Utilities disk and turn the computer on. At the main menu, choose ADJUST TURNTABLES. Select BIG TABLE CENTER. This should send Billy Bob to the back of the stage, roughly in the center (pay no attention to which direction Billy Bob is actually facing). Next, select BIG TABLE CW. This should turn the large turntable clockwise and send Billy Bob to the front-and-center position, give or take a few inches. If Billy Bob ends up in the correct position both times, go on to Step 7.

If Billy Bob does NOT end up in the correct position both times, go directly to the LARGE TURNTABLE SYNC PROBLEM ? section.

Step 7) RUNNING THE SHOW AFTER A "RESET"

Follow the normal procedures for starting up the system, and run a show. When the show is running, note the positions of the characters. If they are not where they should be and are facing the wrong direction, the large turntable is out of sync. See LARGE TURNTABLE SYNC PROBLEM ? section.

DIAGRAM 4A

Billy Bob is front and center.

Main harness is PARTIALLY around the pedestal as shown.

Note: This position is referenced for RESET purposes in some sections of the manual.

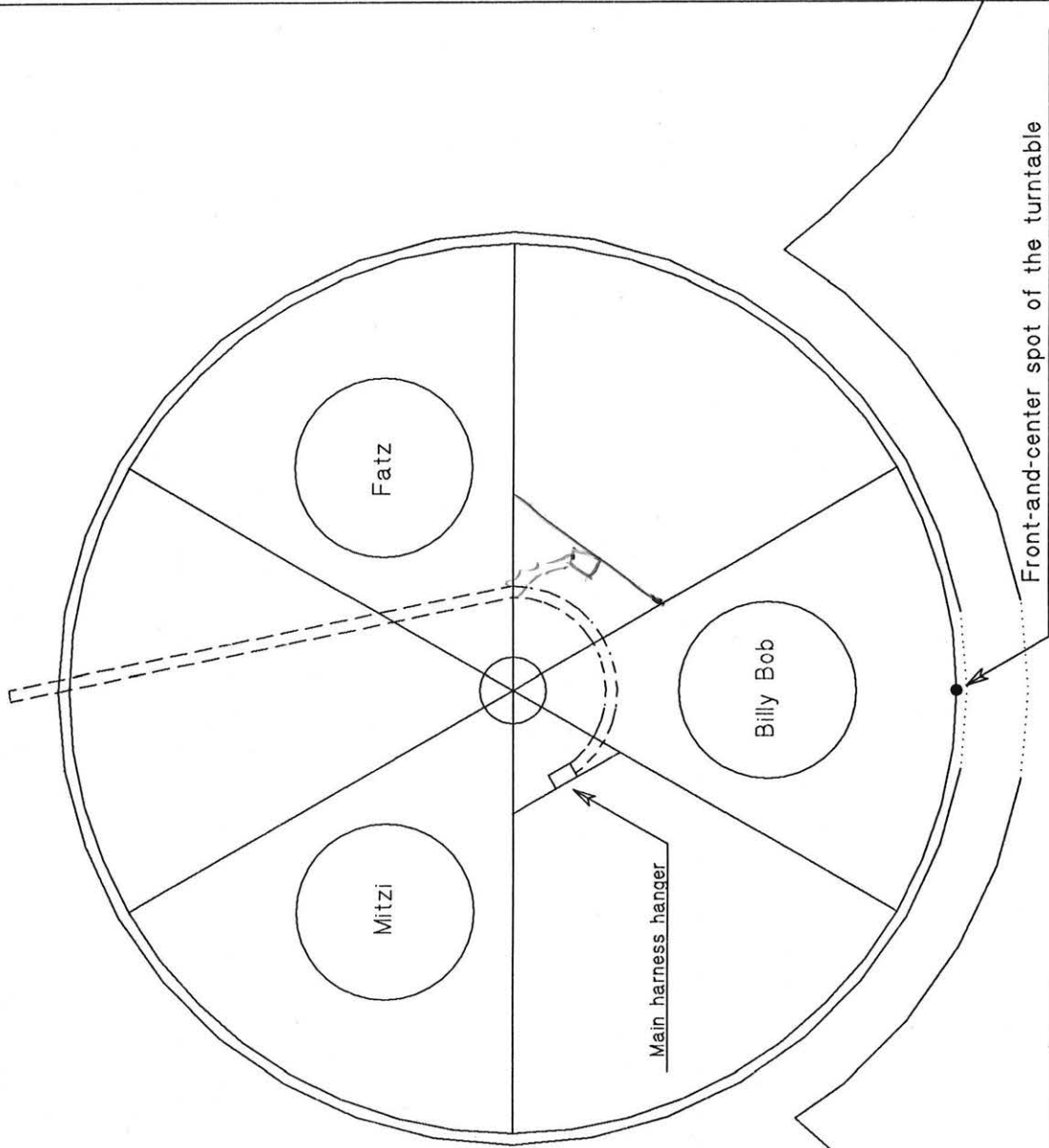

Title: Fully clockwise position (#30 front-and-center)

Date: 04/15/95 Scale: Representational

Tolerance (unless indicated):

Creative Engineering, Inc.
47 West Jefferson Street
Orlando, Florida 32801

DIAGRAM 4B

Billy Bob is close to the large screen TV.

Main harness is PARTIALLY around the pedestal as shown.

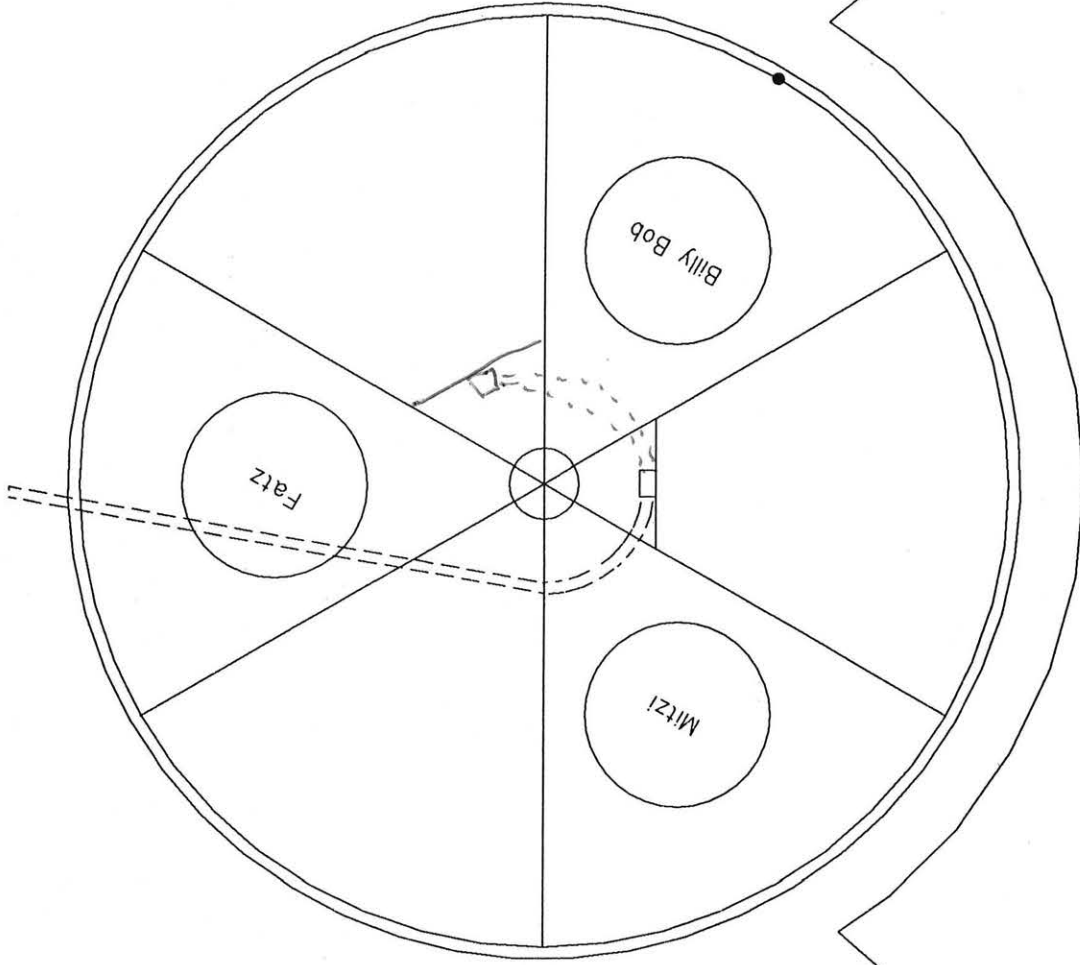

Title:	Fully counterclockwise position
Date:	04/15/95
Scale:	Representational

Tolerance (unless indicated):	Creative Engineering, Inc. 47 West Jefferson Street Orlando, Florida 32801
-------------------------------	--

DIAGRAM 4C

Turntable is beyond the normal extreme clockwise position.
 Main harness is PARTIALLY around the pedestal as shown.

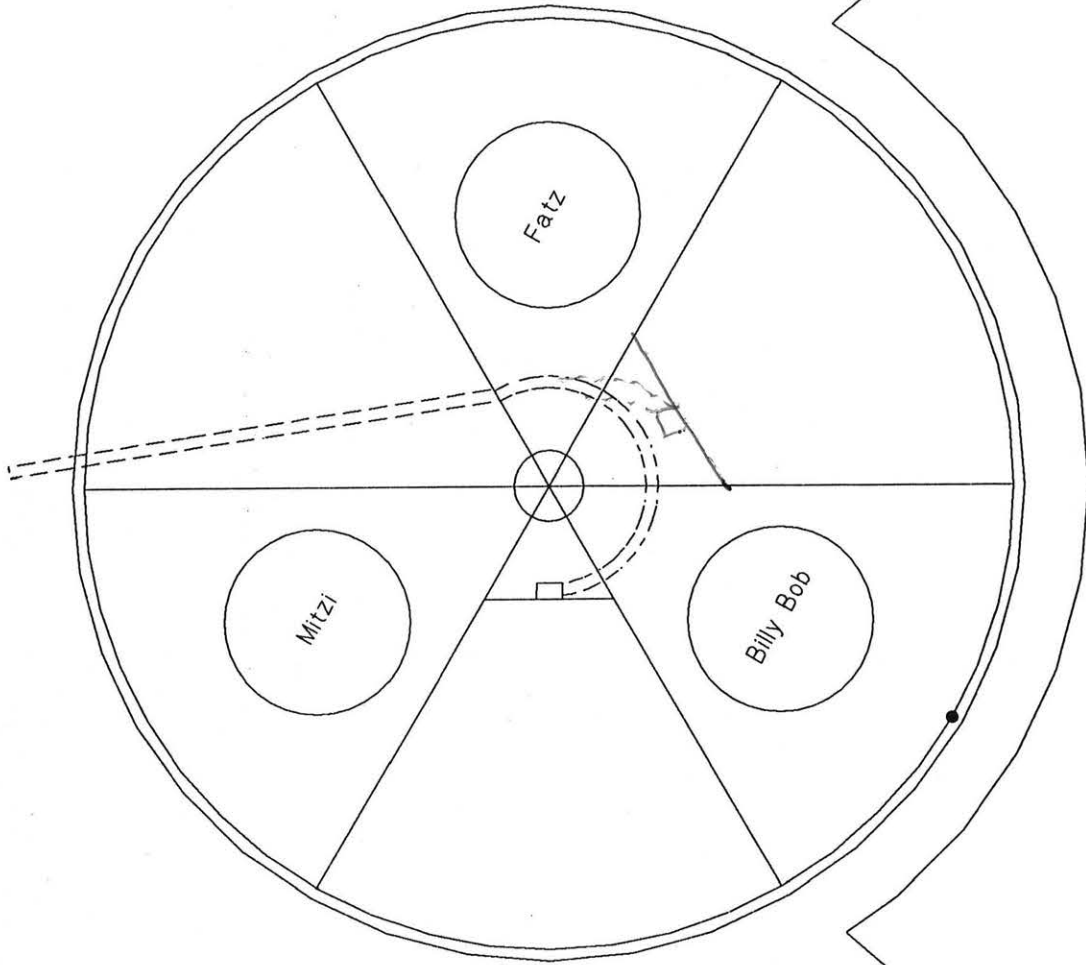

Title: Beyond fully clockwise position, limit switch triggered

Date: 04/15/95 Scale: Representational

Tolerance (unless indicated):

Creative Engineering, Inc.
 47 West Jefferson Street
 Orlando, Florida 32801

DIAGRAM 4D

Turntable is beyond the normal extreme counterclockwise position.

Main harness is PARTIALLY around the pedestal as shown.

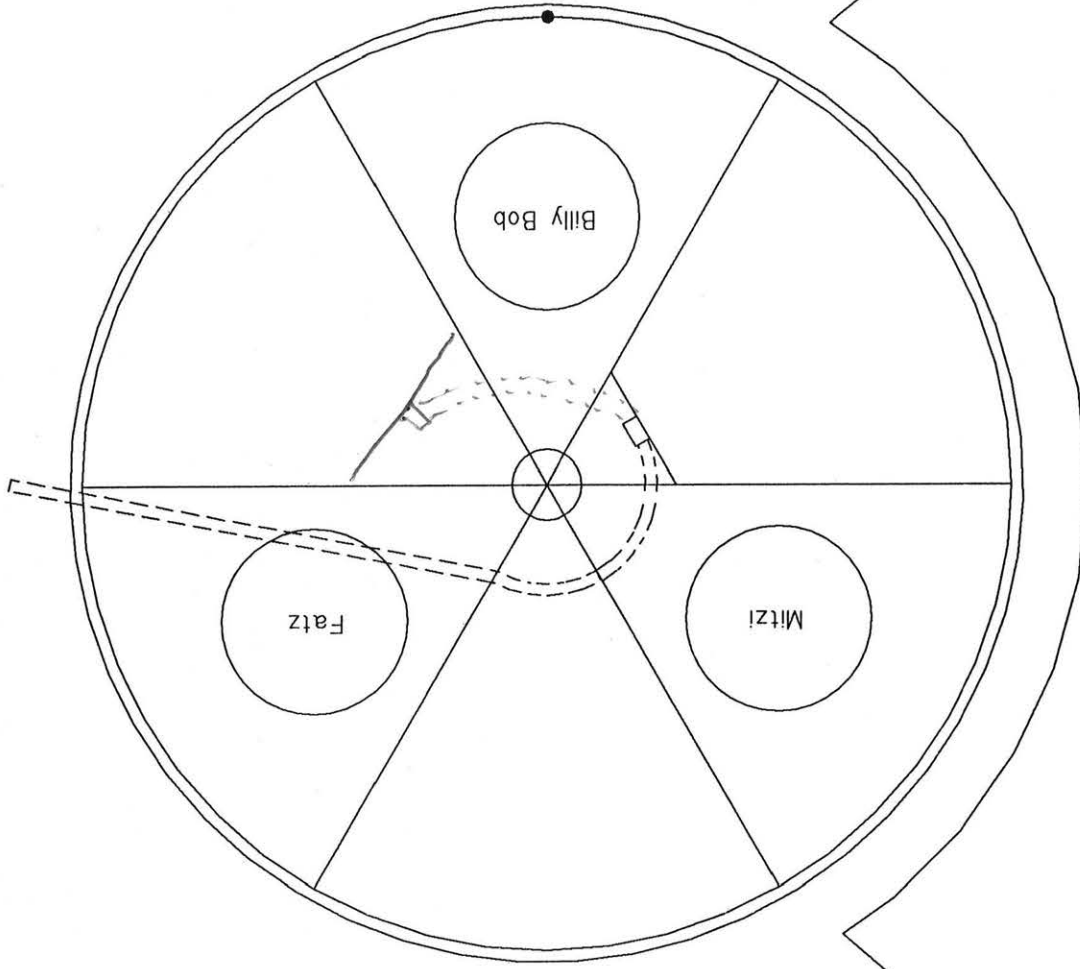

Title: Beyond fully counterclockwise position, limit switch triggered

Date: 04/15/95 Scale: Representational

Tolerance (unless indicated):

Creative Engineering, Inc.
47 West Jefferson Street
Orlando, Florida 32801

DIAGRAM 4E

Billy Bob is front and center.
 (Don't confuse with diagram 4A)
 Main harness is BARELY around
 the pedestal as shown.

Note: This position is referenced
 for RESET purposes in some sections
 of the manual.

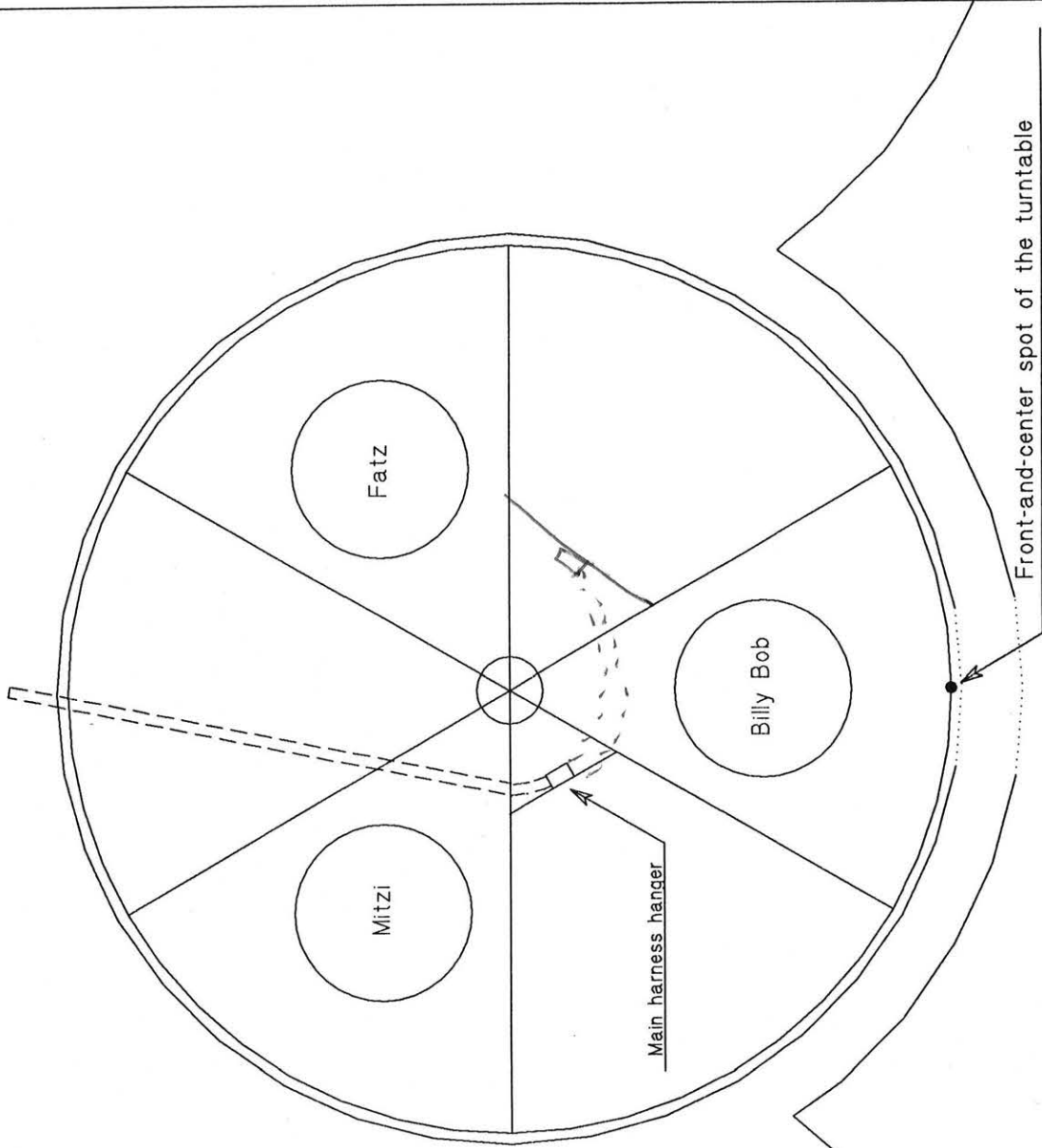

Title: #1 front-and-center

Date: 04/15/95

Scale:

Representational

Tolerance (unless indicated):

Creative Engineering, Inc.
 47 West Jefferson Street
 Orlando, Florida 32801

9/16" 1" FROM HUB

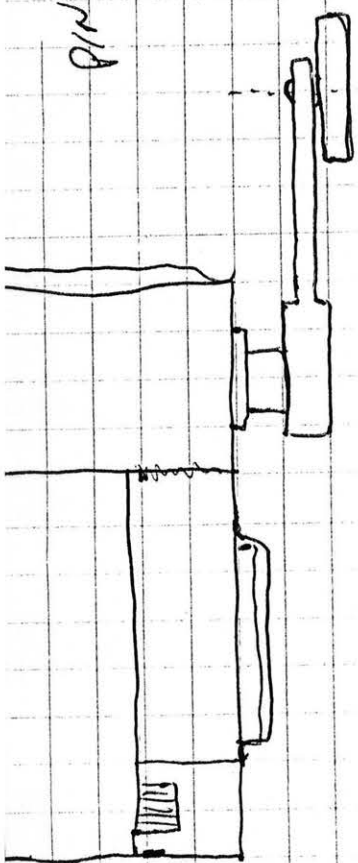

9/16"

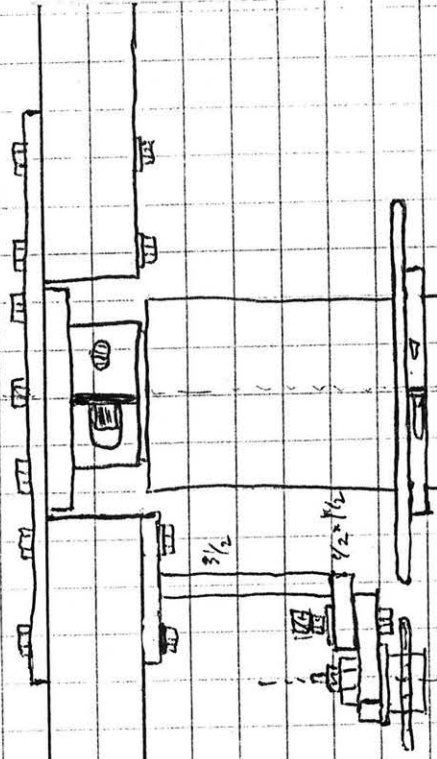

3/2"

1/2" x 1/6"

LARGE TURNTABLE SYNC PROBLEM ?

As noted in the last section, there is a direct relationship between the large turntable and the feedback gear. The exact position of the turntable is determined by the exact position of the feedback gear. When the turntable and the feedback gear are in perfect sync, the position information sent to the Big Important Board is correct. As a result, when the Big Important Board "thinks" the table is at position 12, the table actually IS at position 12. If, however, the table and feedback gear get OUT of sync, the feedback gear will continue to send position information to the Big Important Board, but the ACTUAL position of the table will be altogether different and unpredictable.

HOW DOES IT HAPPEN?:

There is only ONE way for the large table to get out of sync. First, the table must travel too far in either direction (go past the extreme clockwise or extreme counterclockwise position), triggering the limit switch. This can happen if the turntable speed is too fast and drifts into the switch, or if a person pushes the table until it hits the switch. In either case, the limit switch turns off air pressure to the turntable motor. Second, a person must manually push the table farther in the wrong direction (farther past the extreme position), causing the pin that contacts the limit switch to go completely PAST the switch, allowing the switch to reset, returning air to the motor. At this point, if a show is run, the turntable will likely turn, BUT the table and the feedback gear are no longer in sync.

To go into greater detail, the pedestal gear and the feedback gear have different numbers of teeth. The feedback gear is larger (60 teeth) than the pedestal gear (48 teeth). Consequently, the two gears do not have a 1-to-1 ratio. The actual ratio is 5-to-4 to allow the turntable to travel about 50 degrees MORE than one complete revolution while the feedback gear makes LESS than one revolution.

If the table is manually pushed far enough to go all the way PAST the limit switch, the table and gear will be OUT of sync by as much as 180 degrees. So, the characters will always be in the wrong positions and will always be facing the wrong way. EVEN WORSE, the main harness will get wrapped as much as TWICE around the pedestal. Even with slack in the harness, this situation can and PROBABLY WILL CAUSE DAMAGE to the turntable and/or harness. If the table is out of sync, stop the show immediately and do the following:

PUTTING THE TURNTABLE BACK IN SYNC:

Step 1) SAFETY FIRST:

Disconnect the air line that feeds the large turntable air motor. If you have not already turned off the computer, turn it off now. You may need to get under the large turntable for inspection, and certain corrective measures might cause the table to move suddenly if air pressure is still applied to the air motor.

Step 2) INSPECTION

Refer to diagrams 4A and 4B again. Keep in mind that these two diagrams clearly show the absolute most that the harness should be around the pedestal in either extreme position. In both diagrams, note that the harness is not actually "wrapped" around the pedestal at all. In diagram 4B, the harness hanger (the aluminum channel that pulls the harness around) doesn't even go beyond the front of the pedestal. In 4A, the harness hanger goes just barely past the front of the pedestal.

Look under the turntable from behind the stage, remove any extra slack in the harness, and carefully note the lay of your harness in relation to the pedestal. If the harness is wrapped too much in one direction, the stage will need to be manually pushed (rotated) in the opposite direction as described below.

Step 3) MOVING THE TABLE:

WRAPPED TOO MUCH CLOCKWISE - If the harness is wrapped around the pedestal too much in the clockwise direction, then have someone push the turntable counterclockwise until Billy Bob is front-and-center (if, while pushing, the pin contacts the limit switch, keep pushing right on past it). The relationship between your harness and the pedestal should now resemble diagram 4A. If they do, skip down to Step 4. If your harness is NOT currently lying the same as pictured in the diagram, then your stage must have been WAY out of sync, and you will have to determine which way the turntable needs to be turned to get your table and harness to the positions in diagram 4A. (If your table was this far out of sync, take the time to carefully inspect the harness and where it connects to the hanger for damage.) When the table and harness are correctly set (diagram 4A), skip down to STEP 4.

WRAPPED TOO MUCH COUNTERCLOCKWISE - If the harness is wrapped around the pedestal too much in the counterclockwise direction, then have someone push the turntable clockwise until Billy Bob is front-and-center (if, while pushing, the pin contacts the limit switch, keep pushing right on past it). The relationship between your harness and the pedestal should now resemble diagram 4E. If they do, skip down to Step 4. If your harness is NOT currently

lying the same as pictured in the diagram, then your stage must have been WAY out of sync, and you will have to determine which way the turntable needs to be turned to get your table and harness to the positions in diagram 4E. (If your table was this far out of sync, take the time to carefully inspect the harness and where it connects to the hanger for damage.) When the table and harness are correctly set as (diagram 4E), go on to Step 4.

Step 4) PUTTING THINGS BACK:

Reconnect the air line to the air motor.

Step 5) PRESSING THE RESET BUTTON:

The procedures for this operation are fully described in the preceding section. Go to LARGE TURNTABLE section, Step 5.

NO DATA TO / FROM TURNTABLES

PROPS / LIGHTS

There are a series of props mechanisms on the new RAE show. The valve banks for the props are located under each side stage and behind the center turn mechanism. On stage left the props valve bank controls the stage turn mechanism and four ear raise mechanisms. The stage turn valve forces air over the oil reservoirs and the oil travel into the cable cylinder. This is the most important closed system in the show. Because it uses oil and not just air any leak will create quite a mess. Check this mech frequently to insure there are no leaks. It is very important to see that the cables are not rubbing and cause a nose seal leak in the cylinder. If you get a nick in the cable you will need to change out that cable. If you notice that there is not enough oil in one side of the system you can easily move some from one side to the other by using the bypass valve under the tanks. If you need to add oil use only hydraulic fluid. There is a fill cap on the top of each tank. Cables should be kept tight but not excessively so. Flow controls on the ends of each cylinder control the speed and may need to be set from time to time. The turntable should move as rapidly as possible without bouncing at the end of the travel.

The ear mechanisms contain one valve each and a spring cylinder with two flow controls in series between. Because this has a spring cylinder you should control the speed of the movements by each flow. One for each direction. Flows are located under the stage.

The center stage valve bank controls the curtain raises and speaker movement cylinders. The curtain raise cylinders operate on air and can be adjusted by the flow controls on the each end of the cylinders. Again it is important that the cables are kept free from damage or air leaks will occur at the ends of the cylinders. If you are getting air passing between chambers you may need to put some CEI lube or oil in the cylinder to ensure that the U-cups are sealed. The cylinders that control the speaker movements have flow controls located between each pair of speakers. These cylinders are repairable.

Stage right props valve bank also have an oil turn mechanism as on the left side. It also contains a valve that controls the coconut drop. The flows are located under the stage and the cylinder is in the hacienda. This cylinder cannot be repaired and must be replaced. The window open mech is also on this valve bank and can be adjusted under the stage. There is also two small pressure adjustment knobs on this movement. These should be set so that only about 25 PSI of air pushes this movement. The flow controls adjust the speed. The cylinder for this movement is in the hacienda and is unrepairable.

PROPS VALVES

VALVE	MOVEMENT
1- SL	STAGE LEFT TURN
2- SL	RABBIT EAR- TOP LEFT
3- SL	RABBIT EAR- TOP RIGHT
4- SL	RABBIT EAR- BOTTOM LEFT
5- SL	RABBIT EAR- BOTTOM RIGHT
1- CTR	STAGE LEFT CURTAIN
2- CTR	CENTER STAGE CURTAIN
3- CTR	STAGE RIGHT CURTAIN
4- CTR	LEFT SPEAKERS
5- CTR	RIGHT SPEAKERS
1- SR	STAGE RIGHT TURN
2- SR	BEACH BEAR WINDOW
3- SR	COCONUT DROP

MAINTENANCE

Maintenance Schedule:

DAILY

- Upon air up check for air leaks
- Visually inspect characters and set for abnormal wear or broken parts.
- Lubricate eyes and eyelids every three days. Remove old lube before applying new. Only use a soft rags for wiping, no paper towels.
- Power up system and insure all systems are functioning properly.
- Check oilers and fill as needed.
- Once air system is on check characters by physically pushing on various areas to discover any broken movements.
- Play several shows and check for any obvious mechanical problems or sound problems.
- Brush fur and blow off characters every couple of days to prevent matting of fur.

WEEKLY

- Drain water filters.
- Check pressure gauge for 80 psi setting.
- Cycle curtain cylinders and inspect for proper operation.
- Run turntable turn program and check speed settings. Adjust as needed. Small tables should be 6.0-6.4 and the large table should be 13.5-14.5. Ideally a setting in the middle of those ranges is perfect.
- Do a more thorough inspection of the characters for problem mechanisms.
- Check side turntable oil reservoirs and be sure enough oil is on each side of piston. Run movement from one side to the other to check oil level. Be sure neither side totally fill up. Use bypass valve beneath tanks to change levels. If oil is needed add only 30w. hydraulic fluid. Check for leaks on fittings and on cable cylinders.

MONTHLY

- Thoroughly inspection one character on a rotating basis. Remove all costumes and fur parts including mask to do this inspection. Expose valve bank and manually press each valve override and check movement for proper operation. No slamming should occur and motion should be fluid and unbinding. At this time you should be able to see any problems or potential problem areas. If a parts is needed and you don't have the part on hand at the time close that movements flow controls until that part is received. It is recommended that you keep your parts inventory up at all times. If you use your last part of an item reorder another immediately. Parts are cheap and will save you money in the long run.

- Inspect air lines for possible wear areas and protect areas where wear is noticed.
- Climb under stage and inspect turntable parts. Look for loose or missing bolts. Check for hoses or wires rubbing. Be sure chains are not loose or have fallen off. Check 1/4" screws holding diamond plate and wooden running boards onto turntable. If loose loc-tite these bolts.
- Clean infrared transmitters and receivers under stage by using air blow gun. This is to ensure a good reading by these devices.
- Check wire harnesses on turntables for wear.
- Do compressor maintenance as prescribed by manufacturer.
- Check curtain cables and pulley systems for wear or binds.
- Check main drive motor system and tire for wear. Replace tire as tread is worn off. Be sure to remove old rubber wear with a vacuum.
- General housekeeping should be done at this time to ensure a clean and sparkling set. Dusting of props and vacuuming of set is recommended.
- Check inventory of parts and supplies and order as needed.

Terms and Definitions-

FLOW CONTROLS- Devices used to meter the air flow from cylinders. These are used to control the speed of the movements.

INFRARED FEEDBACK- These are used to sense where the turntables are at any given time. Used for positioning of characters during the show.

CYLINDERS- Devices used to move mechanical levers. Pancakes are ones that are orange in color. Arm twist movements use rotary actuators as cylinders. Double acting cylinders mean they have two air lines feeding them and are driven by air in each direction of travel.

CLEVIS- a mechanical part mounted on the piston shaft of a cylinder and used to push a mechanism. They are forked shaped with a threaded end and a hole through the forked end.

PISTON- The shaft portion of a cylinder. It contains an O-ring on one end that serves as a seal between the two chambers of the cylinder. Pistons should be kept lubricated at all times.

OILERS- Located at the air distribution manifold, these serve as lubricators for the valves and air motors. They should be kept full of 10w. non-detergent oil.

AIR MOTORS- used to turn the center turntable and small inner turntables. They contain two ports and are fed from a 24v. valve.

VALVES- They switch the air from one side of the cylinder to the other to accomplish the movement. They are normally 24vdc. They should be kept lubricated and free of dirt and water.

QUICK RELEASES- Used to allow easy removal of the valve banks for repair. Most are 10 tube releases and have a red clip that slides to one side allowing the two sides to be pulled apart.

REGULATOR- Controls the air pressure for the show and is mounted to the distribution manifold. A special wrench is needed to adjust this device. The pressure on the show should be kept at 80 PSI at all times.

WATER SEPARATOR- Filters water from the system and must be drained regularly. Located next to regulator.

PUSH LOC HOSE- Gray hose used to feed various valves and cylinders. 1/4" and 3/8" are used on this show.

TRIAC- Used to control lighting effects. Low voltage goes in one side and high voltage comes out on the other. These are located in the lighting control panel in the back of the show.

TRANSFORMER- Used to power the neon lights. Mounted on the walls behind the show they can be adjusted for intensity by use of the adjustment knob.

SPOTLIGHTS- These light up the front of the characters during singing sections. They have fixed iris's and take a 500w. EHD bulb.

PAR 46 CANS- Contain a 200w. bulb and are used to add color to the various set areas.

VALANCE- Curtain section mounted on the top header board and used to hide the curtain raise mechanisms.

CABLE CYLINDERS- Used to raise the curtains and also used to turn the side stages. Operate the same as normal cylinders but drive a cable around a pulley to allow longer stroke.

PLUMBING HARNESS- Grouping of hoses attached to the characters providing air to the cylinders. Placed in a harness to allow easy installation and removal from the figures.

CHARACTERS- Animated figures use in the show. These include Billy Bob, Fatz, Mitzi in all shows. Looney Bird, Beach Bear and Dook in full shows only.

COSTUMES- Clothing worn by the characters.

BODY PANELS- Plastic panels used to add form to the figures and keep the clothing from rubbing the mechanisms. These include Body pieces, Upper arms, lower arms, upper legs, lower legs, shoulder pieces and skulls.

CLIPPARD CYLINDERS- Single acting cylinders using a spring return on one side. A single hose is used to feed this cylinder and two flow controls are used to control the speeds. Used on the rabbit ears.

MUFFLERS- Used to muffle the noise of the exhausting air from cylinders and air motors. Should be kept clean and free from blockage.

POWER SUPPLY- Used to provide power to various systems. Main power supply is located on bottom rack of audio rack. Power supply for turntable board is located on the same shelf. Power supply for the apple computer is in the computer. It is critical that all these supplies are operating perfectly.

SERVO- Used to move the eyes and eyelids on the characters. The only electrical devices located in the figures.

BIT STRIPPERS- Mini computers located at each character to send power to move the movements. Also located in light panel to control lights and props.

PROPS- Special devices used to control support systems. Curtains, side table turns, speaker movements, rabbit ears, window opens and coconut drops are some of these. Controlled by a props valve bank for each stage.

CUSTOMER PANEL- Used in show selector system it allows the customer to chose which show they wish to see. Placed out front in the show room.

MANAGER PANEL- Used in show selector systems, it allows the manager to chose special shows such as birthday shows.

PLAYBACK BOARD- Located in the apple computer.

Background of the Rock-afire show

The first Rock-afire Explosion show was produced in 1980 and was placed in a Showbiz Pizza restaurant in Topeka, KS. This show was the first sophisticated animated show to appear in a restaurant. It was highly successful. People lined up outside the store in the dead of winter. From there the chain was expanded to over 220 restaurants. Creative Engineering, part owners of the concept, was in charge of the entertainment in the stores. The Classic Rock-afire grew in popularity and was an integral part of the burgeoning concept. People were amazed that their neighborhood entertainment center now contained Disney-like animation. Competition in this field quickly grew as more players entered the market. Along with the poor economy the concept fell on hard times and a washing out of the industry occurred. Showbiz bought the bankrupt Chuckie Cheese concept and proceeded to use the Chuckie characters exclusively. Creative Engineering proceeded to syndicate the Rock-afire Explosion to various concepts all over the world. Currently, there are Rock-afire shows on every continent except Antarctica. The Rock-afire show software is being translated into several different languages and is expected to add several more in the near future.

In 1992, the NEW Rock-afire Explosion show was introduced at the IAAPA show in Dallas TX. The next generation RAE show was designed to take the form to new heights. Through the use of Revolving turntables, video and customer interaction the RAE is poised to bring a whole new form of entertainment to parks and entertainment centers well into the 21st century. No longer are the characters screwed into one place. They are free to move from place to place on the stage, enabling them to interact with each other, the video screen and the audience. This allows entirely new forms of software to be performed. Educational software will be heavily explored. With the onset of such TV shows as Barney and Sesame St. it seems only natural for the New RAE show to perform a similar function. The show selector system, first developed for the Classic show is now available for the New RAE show with one major difference. No longer will the audience have to wait for a lengthy search. Once the thank you skit is finished the song selection will play instantaneously. With the use of video, spectators will be taken to various places around the world all narrated by members of the cast.

We expect about 6 new RAE shows to be in place by the end of 1994. From Minnesota to Mexico, the new RAE show will entertain and educate a new generation of children. It is our hope that with your help we can provide a service to your community and venture. We will make an effort to keep you posted on the progress and expansion of the new RAE show so that you will have a better understanding of this syndication effort and how it fits into your concept.

Maintenance Schedule:

DAILY

- Upon air up check for air leaks
- Visually inspect characters and set for abnormal wear or broken parts.
- Lubricate eyes and eyelids every three days. Remove old lube before applying new. Only use a soft rags for wiping, no paper towels.
- Power up system and insure all systems are functioning properly.
- Check oilers and fill as needed.
- Once air system is on check characters by physically pushing on various areas to discover any broken movements.
- Play several shows and check for any obvious mechanical problems or sound problems.
- Brush fur and blow off characters every couple of days to prevent matting of fur.

WEEKLY

- Drain water filters.
- Check pressure gauge for 80 psi setting.
- Cycle curtain cylinders and inspect for proper operation.
- Run turntable turn program and check speed settings. Adjust as needed. Small tables should be 6.0-6.4 and the large table should be 13.5-14.5. Ideally a setting in the middle of those ranges is perfect.
- Do a more thorough inspection of the characters for problem mechanisms.
- Check side turntable oil reservoirs and be sure enough oil is on each side of piston. Run movement from one side to the other to check oil level. Be sure neither side totally fill up. Use bypass valve beneath tanks to change levels. If oil is needed add only 30w. hydraulic fluid. Check for leaks on fittings and on cable cylinders.

MONTHLY

- Thoroughly inspection one character on a rotating basis. Remove all costumes and fur parts including mask to do this inspection. Expose valve bank and manually press each valve override and check movement for proper operation. No slamming should occur and motion should be fluid and unbinding. At this time you should be able to see any problems or potential problem areas. If a parts is needed and you don't have the part on hand at the time close that movements flow controls until that part is received. It is recommended that you keep your parts inventory up at all times. If you use your last part of an item reorder another immediately. Parts are cheap and will save you money in the long run.

- Inspect air lines for possible wear areas and protect areas where wear is noticed.
- Climb under stage and inspect turntable parts. Look for loose or missing bolts. Check for hoses or wires rubbing. Be sure chains are not loose or have fallen off. Check 1/4" screws holding diamond plate and wooden running boards onto turntable. If loose loc-tite these bolts.
- Clean infrared transmitters and receivers under stage by using air blow gun. This is to ensure a good reading by these devices.
- Check wire harnesses on turntables for wear.
- Do compressor maintenance as prescribed by manufacturer.
- Check curtain cables and pulley systems for wear or binds.
- Check main drive motor system and tire for wear. Replace tire as tread is worn off. Be sure to remove old rubber wear with a vacuum.
- General housekeeping should be done at this time to ensure a clean and sparkling set. Dusting of props and vacuuming of set is recommended.
- Check inventory of parts and supplies and order as needed.

Terms and Definitions-

FLOW CONTROLS- Devices used to meter the air flow from cylinders. These are used to control the speed of the movements.

INFRARED FEEDBACK- These are used to sense where the turntables are at any given time. Used for positioning of characters during the show.

CYLINDERS- Devices used to move mechanical levers. Pancakes are ones that are orange in color. Arm twist movements use rotary actuators as cylinders. Double acting cylinders mean they have two air lines feeding them and are driven by air in each direction of travel.

CLEVIS- a mechanical part mounted on the piston shaft of a cylinder and used to push a mechanism. They are forked shaped with a threaded end and a hole through the forked end.

PISTON- The shaft portion of a cylinder. It contains an O-ring on one end that serves as a seal between the two chambers of the cylinder. Pistons should be kept lubricated at all times.

OILERS- Located at the air distribution manifold, these serve as lubricators for the valves and air motors. They should be kept full of 10w. non-detergent oil.

AIR MOTORS- used to turn the center turntable and small inner turntables. They contain two ports and are fed from a 24v. valve.

VALVES- They switch the air from one side of the cylinder to the other to accomplish the movement. They are normally 24vdc. They should be kept lubricated and free of dirt and water.

QUICK RELEASES- Used to allow easy removal of the valve banks for repair. Most are 10 tube releases and have a red clip that slides to one side allowing the two sides to be pulled apart.

REGULATOR- Controls the air pressure for the show and is mounted to the distribution manifold. A special wrench is needed to adjust this device. The pressure on the show should be kept at 80 PSI at all times.

WATER SEPARATOR- Filters water from the system and must be drained regularly. Located next to regulator.

PUSH LOC HOSE- Gray hose used to feed various valves and cylinders. 1/4" and 3/8" are used on this show.

TRIAC- Used to control lighting effects. Low voltage goes in one side and high voltage comes out on the other. These are located in the lighting control panel in the back of the show.

TRANSFORMER- Used to power the neon lights. Mounted on the walls behind the show they can be adjusted for intensity by use of the adjustment knob.

SPOTLIGHTS- These light up the front of the characters during singing sections. They have fixed iris's and take a 500w. EHD bulb.

PAR 46 CANS- Contain a 200w. bulb and are used to add color to the various set areas.

VALANCE- Curtain section mounted on the top header board and used to hide the curtain raise mechanisms.

CABLE CYLINDERS- Used to raise the curtains and also used to turn the side stages. Operate the same as normal cylinders but drive a cable around a pulley to allow longer stroke.

PLUMBING HARNESS- Grouping of hoses attached to the characters providing air to the cylinders. Placed in a harness to allow easy installation and removal from the figures.

CHARACTERS- Animated figures use in the show. These include Billy Bob, Fatz, Mitzi in all shows. Looney Bird, Beach Bear and Dook in full shows only.

COSTUMES- Clothing worn by the characters.

BODY PANELS- Plastic panels used to add form to the figures and keep the clothing from rubbing the mechanisms. These include Body pieces, Upper arms, lower arms, upper legs, lower legs, shoulder pieces and skulls.

CLIPPARD CYLINDERS- Single acting cylinders using a spring return on one side. A single hose is used to feed this cylinder and two flow controls are used to control the speeds. Used on the rabbit ears.

MUFFLERS- Used to muffle the noise of the exhausting air from cylinders and air motors. Should be kept clean and free from blockage.

POWER SUPPLY- Used to provide power to various systems. Main power supply is located on bottom rack of audio rack. Power supply for turntable board is located on the same shelf. Power supply for the apple computer is in the computer. It is critical that all these supplies are operating perfectly.

SERVO- Used to move the eyes and eyelids on the characters. The only electrical devices located in the figures.

BIT STRIPPERS- Mini computers located at each character to send power to move the movements. Also located in light panel to control lights and props.

PROPS- Special devices used to control support systems. Curtains, side table turns, speaker movements, rabbit ears, window opens and coconut drops are some of these. Controlled by a props valve bank for each stage.

CUSTOMER PANEL- Used in show selector system it allows the customer to chose which show they wish to see. Placed out front in the show room.

MANAGER PANEL- Used in show selector systems, it allows the manager to chose special shows such as birthday shows.

PLAYBACK BOARD- Located in the apple computer.

MECHANICAL TROUBLESHOOTING

CHARACTER TROUBLESHOOTING

As you will notice many of the parts of these characters are made of plastics. This has been done for many reasons, ease of replacement, lower costs and to reduce weight. This also means that we need to keep an eye on those parts a little closer to ensure proper wear. Due to friction all parts will wear at varying speeds. We use a lubriplate type grease on these parts. It is important that monthly we strip a character to ensure we don't have any excessive wear that could cause a failure and further damage.

Bolts that run through the joints should be well lubricated and should not have any excessive slop. When a figure is aired up and you lightly move the movement you should be able to feel any improper tolerances. If in doubt it is advised that the part be replaced to be safe. This determination at first seems difficult to make but once you become familiar with what is normal and what is abnormal it will be routine. Use white lubriplate grease when greasing a mechanical joint. Be sure to wipe off the old grease before applying more. You should not have an excess of grease oozing from the joints. Anytime you have a character apart you should take that opportunity to clean it inside. You will want to work on a clean character the next time you have to fix something.

Remember mechanical problems left unrepaired will surely lead to more costly artistic parts wear. If a mechanical part breaks it doesn't take long for the cosmetic parts above it to tear.

Air cylinders are well greased during assembly and should last for long periods without regreasing. On some occasions it may be necessary to grease a cylinder. Some cylinders are repairable and others are throwaways. Repairable cylinders are those working the arm raises, elbows, body tilts, knee bends, body turns. You should use CEI lube when rebuilding a cylinder.

There are a series of props mechanisms on the new RAE show. The valve banks for the props are located under each side stage and behind the center turn mechanism. On stage left the props valve bank controls the stage turn mechanism and four ear raise mechanisms. The stage turn valve forces air over the oil reservoirs and the oil travel into the cable cylinder. This is the most important closed system in the show. Because it uses oil and not just air any leak will create quite a mess. Check this mech frequently to insure there are no leaks. It is very important to see that the cables are not rubbing and cause a nose seal leak in the cylinder. If you get a nick in the cable you will need to change out that cable. If you notice that there is not enough oil in one side of the system you can easily move some from one side to the other by using the bypass valve under the tanks. If you need to add oil use only hydraulic fluid. There is a fill cap on the top of each tank. Cables should be kept tight but not excessively so. Flow controls on the ends of each cylinder control the speed and may need to be set from time to time. The turntable should move as rapidly as possible without bouncing at the end of the travel.

The ear mechanisms contain one valve each and a spring cylinder with two flow controls in series between. Because this has a spring cylinder you should control the speed of the movements by each flow. One for each direction. Flows are located under the stage.

The center stage valve bank controls the curtain raises and speaker movement cylinders. The curtain raise cylinders operate on air and can be adjusted by the flow controls on the each end of the cylinders. Again it is important that the cables are kept free from damage or air leaks will occur at the ends of the cylinders. If you are getting air passing between chambers you may need to put some CEI lube or oil in the cylinder to ensure that the U-cups are sealed. The cylinders that control the speaker movements have flow controls located between each pair of speakers. These cylinders are repairable.

Stage right props valve bank also have an oil turn mechanism as on the left side. It also contains a valve that controls the coconut drop. The flows are located under the stage and the cylinder is in the hacienda. This cylinder cannot be repaired and must be replaced. The window open mech is also on this valve bank and can be adjusted under the stage. There is also two small pressure adjustment knobs on this movement. These should be set so that only about 25 PSI of air pushes this movement. The flow controls adjust the speed. The cylinder for this movement is in the hacienda and is unrepairable.

There are four air motors used on this show, three small and one large. They should be kept lubricated by the use of the oiler provided. The valves will also be lubricated by these oilers. If the speed on a turntable is improper it can be adjusted by the flow controls on the side of the valves. They are labeled for CCW and CW. The utility disk program that tests turntables can be used to set the speeds. Check for binds or chain problems if you cannot adjust the speeds properly. There are a series of two chains on the small tables, one for turning the mechanism and one to turn the infrared reader gear. Be sure these mechanisms are properly adjusted and free from dirt or dust. If one of those reader holes become clogged then that reading will be improper. The chain should be snug and not overly tight. The stop should be intact and properly adjusted to protect from over rotation. The center turntable mech is driven by an air motor and a rubber tire. Check the tire for wear if traction is a problem. The tire is held against the drive rim by an air cylinder and a pressure gauge. You should apply just enough air to the cylinder to insure proper traction without slipping. Once the tread is worn off the tire you should replace that tire and be sure to clean the flakes of treads around the motor. The flows and valve that controls the motor is located under the drive motor. The oiler should lube the motor and the valve properly.

Air hoses are used on all movements in this show and can, from time to time, become worn or broken. If you hear an air leak you should locate it and repair the hose by either replacing it or splicing it. Air lines in the characters should be protected from wear against mechanisms.

UNDERSTANDING THE OPERATION OF THE NEW RAE SHOW

- The new RAE show contains many new and exciting features but at the same time contains many devices and concepts that may be unfamiliar to the new owners.

First let me start by explaining what controls the show and how those devices interface. The show controls are all contained on the two video tapes and played back by the two VCR decks. These tapes contain the video played back on the TVs, stereo audio sound played back on the audio system and control data played back on the computer system.

The first of the two vcr decks is an RS-232 controllable search deck made by Panasonic. This is a professional deck and is key to the searchability of the show selector. The apple computer controls this deck via the interface board and cable. Once the tape has been indexed and that index saved to the 3 1/2" floppy disk the computer will be able to find any song that is selected. The outputs of that deck go to the audio inputs on the mixer mounted next to the disk drive. The signal then goes out to the turntable board and the video output goes to the top input on the video decoder board in the apple (slot 1). The reason for the mixer is to control the output level of one of the decks. Because both vcrs use the same sound system it is important that the volume outputs of both decks are matched. This is done by adjusting the mixer controlling the top deck to match the second deck level. This must be done by ear and could change slightly when a new tape is installed in either deck. Be sure the output of the audio select on the front of the deck is always selected as stereo L & R out.

The second vcr deck used in the system is a home stereo audio vcr made by RCA. This deck is controlled by an infrared remote controlled wired to the turntable control board. Be sure that the batteries in this remote are replaced at least once every 6 months. The stereo audio outputs of this deck go into the inputs on the turntable board. The video output of this deck go to the bottom inputs on the back of the video decoder board. The power for this deck must be manually turned on when the system is turned on at the beginning of the day. Be sure to keep the dust and dirt off the remote transmitter and the infrared receiver on the deck. These decks should be cleaned monthly using a GOOD head cleaner and should be serviced at least once a year by a qualified technician to clean, lube and tighten the belts.

From the vcrs the signs go two ways, one to the audio system and the other to the computer system. The audio inputs that go to the turntable board do so so that it can be turned off by the computer when that deck is not to be playing out to the speakers. This is used in searches and when the other deck is playing. When the computer tells the turntable board to pass on one of the audio signals the signal passes onto the equalizer. The equalizer is there to control the tone of the sound going to the amps. For the most part this device should be kept flat. That is leave all the settings on the center of each scale. There is a tiny spot where they click, set them there. If you have a professional sound person who can set the frequencies to your room then you can have it adjusted. It is our experience that for the most part the average person will not know what a proper setting is for eq. We are striving to have all tapes leaving CEI to operate best flat on the eq. There is also a level out adjustment. Set it to the middle of the range and adjust the levels after this device.

From the equalizer the audio travels to the cross over inputs. From there it goes two ways. The high outputs go to the main amp and the low outputs go the summing amp mounted on the side of the rack. There are two inputs into this device and one output. This device combines the two channels on low frequencies into one so that the mono sub woofer amp has all the music being played through it. The main amp is used to drive the 8 EV monitor speakers placed around the room. It should be run in stereo. The two connections in the back for the speakers each feed 4 speakers. Two are hooked in parallel and two in series. This insures the amp is working at 8 ohms. Volume levels may be adjusted on the amp but it is advised that the amp be set as close to 0 on the knob and the volume controlled using the eq level out. The amp is most efficient at this setting. The sub woofer amp is mono and is connected to the sub woofer speaker mounted under the front of the stage. The volume should be adjusted by the knob on the amp. It is advised that this level be set so as to comfortably provide bass to the room and not to over power the customers.

Now back to the video and control signals for the show. You will recall that the video inputs from the two vcrs has gone into the video decoder board in the apple. The output of that board, on the keyboard end of the board goes to the video input on the turntable board. This signal is amplified by that board and is sent out to any tv monitors in the system.

The video is also used by the computer to control the movements, lights and turntable movements. This takes place with the help of the playback board (slot 3). There are two outputs on that board and are on the keyboard end of the board. The top output is referred to as the top drawer signal and the bottom one as bottom drawer signals. The top drawer signals go out to the top drawer character's bit stripper boards. Those are Billy Bob, Fatz, Mitzi and Dook. The bottom drawer signals go the turntable board input. In his way the turntable bits are used by that board to position the turntables. They also go out of that board to the lighting and props bit strippers and then onto Looney and Beach Bear bit strippers.

Other devices present in the main rack controller are the computer disk drive connected to the computer via the disk drive interface cable and board (slot 5). Only CEI disks will work on this system, do not try any IBM formatted disks. The light pen/modem board is located in the computer and along with the light pen enables the operator to make option selection on the computer monitor. It is very important that the computer monitor be bright enough to provide the light pen with a source it can read. It is advised that the monitor be turned off when not being used even when the show is operating. You should become familiar with the contrast and brightness knobs on the monitor to adjust it as needed. The power supply in the computer is heavy duty and could possibly go bad. You have been provided with an extra just in case. It is advised that if the spare is used you order another back up right away. It is one of the few items in the systems that can prevent total operation.

At the bottom of the rack is the main power supply that runs the show. This supply is specially made and should only be replaced with an identical one. This supply provides 24vdc and ground, 5vdc and ground and 8.5vdc and ground. The 24v. runs the air valves, the 5v. runs the servos for the eye movements and the 8.5v. runs all the computer logic on the bit strippers (controllers).

Also in the rack is the much referred to turntable board. This board is mounted flat on a shelf under the second vcr deck. This board has its own power supply and is tied to the main power supply by two wires. This board controls many things in our system. It switches audio sound between decks. It receives bottom drawer signal it uses and then resends it to the next stripper. It amplifies the video signal and sends it to the TVs. It interfaces to the large turntable via a 24 pin connector to receive feedback and send commands to the turntable. It interfaces to the search deck via a serial interface card in the computer to search for shows. (slot 2) It interface to the second vcr to start, stop and rewinds that deck as needed. It sends the signal out that turns on the strobe light. It has a play on command interface for hooking a N/O button to. And lastly it has an output to control the valve that turns the large turntable. This board is the most complex and most important board in the system. Be sure you know what your doing before messing with it. You should probably be in contact with Max at CEI before trying to repair it.

DEVICES OUTSIDE THE MAIN SYSTEM RACK

The first system to understand is the bit stripper system. This system consists of several boards that have a particular function to operate. Each character has one bit stripper. The lights are controlled by one as are the props valves. These boards are identical except for the 6801 processor that is installed in them. This makes it specific to the task of operating a particular character. The only exception to this is the light bit stripper. Because that board controls 24 lighting effects it has been modified from the 22 bit controllers used elsewhere. These boards are being fed with a power cable supplying 24v, 5v and 8.5v. This connection is made through the 6 pin molex connector on the board. The board also are fed by a data line supplying the computer signal containing the digital data. If there is another board down the line from that one it has a data line out to the next bit stripper. On character bit strippers a 6805 prom is installed to control the eye and eyelid movements. The props and the lighting controllers do not have a 6805 prom as they have no eyes to control. On the character bit strippers a 9 pin molex cable is connected to control the servos in the head of the figures. This connector is mounted at 90 degrees on the board. The 24v outputs on the board are feed to the interface boards or the input to the triacs via a 26 pin ribbon cable. The valve interface board is used when connecting to a valve bank or the props valve bank. The ribbon cable used for the light controller is wired to the 24v inputs to the triacs that switch the high voltage power to the lights.

The lighting controller is mounted to the wall and is wired to the circuit breaker panel and on to the lights themselves. The triacs used in this system require 24 vdc inputs from the bit stripper and send out 120vac to the lights. The triacs are wired to the circuit breakers that feed them with the 120v. hot leg. There is typically 6 triacs on one circuit breaker. The main service to the circuit breaker panel is fed with about 60 amps of 120v power single phase.

The bit strippers for the lights and props valves are located in a silver box mounted under the lighting controller. The props bit stripper is connected to a valve interface board. The props valve bank cables are wired to this board also. The chart for this wiring is found in the manual. There are also a series of 7 switches that are in parallel to these valve that are manual overrides to the most used props function. The functions that have manual overrides are: 3 curtain raise, side turntable turns and Beach Bear window open. Because these function must be opened or turned from time to time during maintenance we have installed these overrides switches. They should be labeled on the cover of the panel. Keep this panel and the lighting panel covered when not being worked on.

There is a bit stripper located at each character that controls the movements for that figure. The center stage character have a bit stripper mounted in the round bases that hold the figures. Looney's bit stripper is located in the second door behind the desk. The door may be unscrewed and the valve bank will fold down revealing the bit stripper. They are fed by the power and data cables. Beach Bear's bit stripper is located in the trap door behind the base of the coconut tree. Dook's bit stripper is located in the base of the junkyard house. In the case of Dook the data comes in from the computer and then out to the center turntable for distribution to the three other figures on the table. Bit strippers main 6801 microprocessors are labeled for the bit stripper they belong to. They cannot be mixed up and used for figures other than labeled. They will work but they will play the wrong movements through the figures.

The next major system in the show is the four turntables. There are three small tables and one large table. The three small ones are essentially the same except that they move a specific character when plugged into that input. From the main rack we have three main feeds to the turntable. The 24 pin cable is connected to the turntable interface board as is an 18 gauge power distribution cable along with the data from the Dook bit stripper or the main playback board in the case of a Lite show. The power cable lands on the board and has feeds off to each character. The data lands and is feed to each character. The 24 pin cable is distributed to infrared power feed, turning valve feeds and to infrared feedbacks. Each character turntable has an infrared turntable power wire on the emitter board (2 wire) and a 6 pin cable to the infrared receiver board. In order to position

the characters according to the program a series of holes drilled in the reader gear allow the emitter to transmit the light to the receiver. Once the computer in the turntable board reads a position the character stops there. The sprocket has 15 positions on the small tables and 31 positions on the large table. The data and power cables that feed the character bit strippers pass through the center hub on the character turn mechanism. These cables are protected by a nylon sleeving. Each turntable motor is controlled by a dual acting valve. This valve is turned on and off by the turntable controller depending in which direction it has to move. That valve is connected to the interface board via three pin molex connector.

That is essentially how the whole system works. The air and mechanical system is discussed in another section.

Big Important Board (BIB)

formerly known as Turntable Board^x

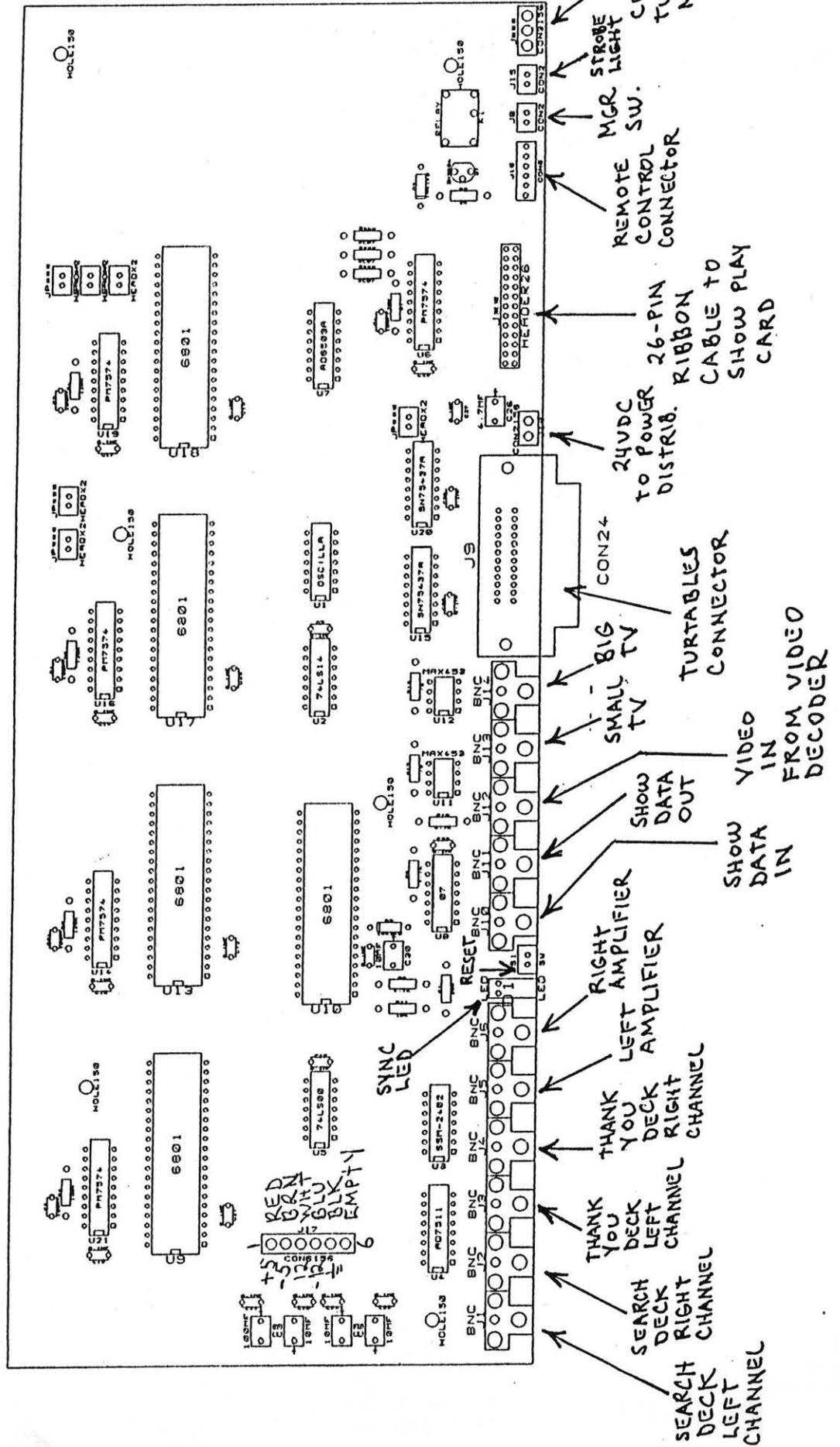

VALVE BANK LAYOUT

VALVE #	MOVEMENT (ALL BUT LOONEY)	MOVEMENT (LOONEY ONLY)
1	MOUTH	MOUTH
2	LIP	LIP
3	HEAD UP	HEAD UP
4	HEAD TURN RIGHT	HEAD TURN RIGHT
5	HEAD TILT LEFT	HEAD TILT LEFT
6	RIGHT WRIST	RIGHT WRIST
7	RIGHT ELBOW	RIGHT ELBOW
8	RIGHT ARM TWIST	RIGHT ARM TWIST
9	RIGHT ARM RAISE	HEAD TILT RIGHT
10	RIGHT SHOULDER RAISE	RIGHT SHOULDER
11	LEFT WRIST	LEFT WRIST
12	LEFT ELBOW	LEFT ELBOW
13	LEFT ARM TWIST	LEFT ARM TWIST
14	LEFT ARM RAISE	BODY TURN RIGHT
15	LEFT SHOULDER RAISE	LEFT SHOULDER
16	HEAD TILT RIGHT	HEAD UP (WINDOW)
17	BODY TURN RIGHT	HEAD TURN (WINDOW)
18	BODY TILT LEFT	MOUTH (WINDOW)
19	BODY TILT RIGHT	LIP (WINDOW)
20	KNEES BEND	COMPUTER SWIVEL
21	EARS (DOOK AND MITZI)	

PROPS VALVES

VALVE	MOVEMENT
1- SL	STAGE LEFT TURN
2- SL	RABBIT EAR- TOP LEFT
3- SL	RABBIT EAR- TOP RIGHT
4- SL	RABBIT EAR- BOTTOM LEFT
5- SL	RABBIT EAR- BOTTOM RIGHT
1- CTR	STAGE LEFT CURTAIN
2- CTR	CENTER STAGE CURTAIN
3- CTR	STAGE RIGHT CURTAIN
4- CTR	LEFT SPEAKERS
5- CTR	RIGHT SPEAKERS
1- SR	STAGE RIGHT TURN
2- SR	BEACH BEAR WINDOW
3- SR	COCONUT DROP

RAE93 BIT CHART

CHARACTERS

	MITZI	BBOB	FATZ	DOOK	BBEAR	LB LAB	LB WIN
MOUTH	01T	21T	41T	61T	21B	1B	16B
LIP	02T	22T	42T	62T	22B	2B	17B
HEAD DOWN	03T	23T	43T	63T	23B	3B	18B
HEAD TURN	04T	24T	44T	64T	24B	4B	19B
HEAD TILT LEFT	05T	25T	45T	65T	25B	5B	
HEAD TILT RIGHT	16T	36T	56T	76T	36B	9B	
EARS	105T			106T			
LEFT BODY TILT	18T	38T	58T	78T	38B		
RIGHT BODY TILT	19T	39T	59T	79T	39B		
LEFT WRIST	11T	31T	51T	71T	31B	11B	
RIGHT WRIST	06T	26T	46T	66T	26B	6B	
LEFT ELBOW	12T	32T	52T	72T	32B	12B	
RIGHT ELBOW	07T	27T	47T	67T	27B	7B	
LEFT ARM TWIST	13T	33T	53T	73T	33B	13B	
RIGHT ARM TWIST	08T	28T	48T	68T	28B	8B	
LEFT ARM RAISE	14T	34T	54T	74T	34B		
RIGHT ARM RAISE	09T	29T	49T	69T	29B		
LEFT SHOULDER	15T	35T	55T	75T	35B	15B	
RIGHT SHOULDER	10T	30T	50T	70T	30B	10B	
KNEE BEND	20T	40T	60T	80T	40B		
BODY TURN RIGHT	17T	37T	57T	77T	37B	14B	

SERVOS

EYES RIGHT	83T	89T	95T	101T	65B	52B
EYES LEFT	82T	88T	94T	100T	64B	51B
EYES DOWN	85T	91T	97T	103T	67B	54B
EYES UP	84T	90T	96T	102T	66B	53B
LIDS CLOSE	86T	92T	98T	104T	73B	55B
LIDS OPEN	81T	87T	93T	99T	63B	50B

PROPS

COMPUTER SWIVEL	20B
LARGE TV	75B
SMALL TV	76B
BBEAR WINDOW	43B
COCONUT DROP	44B
SPEAKER LEFT	45B
SPEAKER RIGHT	61B
RABBIT EARS TOP LEFT	46B
RABBIT EARS TOP RIGHT	47B
RABBIT EARS BOTTOM LEFT	48B
RABBIT EARS BOTTOM RIGHT	49B

TURNTABLES

CENTER STAGE	68-72B
MITZI	77-80B
BILLY BOB	85-88B
FATZ	93-96B
STAGE RIGHT	41B
STAGE LEFT	42B

CURTAINS

STAGE LEFT CURTAIN	58B
STAGE RIGHT CURTAIN	59B
CENTER STAGE CURTAIN	60B

LIGHTS

STAGE LEFT SPOT	101B
STAGE RIGHT SPOT	102B
CENTER STAGE LEFT	103B
CENTER STAGE CENTER	104B
CENTER STAGE RIGHT	105B

ORGAN LIGHTS	106B
COLOR LIGHTS #1	109B
COLOR LIGHTS #2	110B
COLOR LIGHTS #3	111B
COLOR LIGHTS #4	112B
COLOR LIGHTS #5	113B
COLOR LIGHTS #6	114B
COLOR LIGHTS #7	115B
COLOR LIGHTS #8	116B
COLOR LIGHTS #9	117B
STAGE RIGHT FLOOR SPOTS	57B
STAGE LEFT FLOOR SPOTS	74B

STAR STROBES	118B
LOONEY BIRD LIGHT	97B
DOOK WINDOW	98B
STROBE	81B
ROCKAFIRE NEON	108B
EXPLOSION NEON	119B

CONTROLS

STOP	99B
REWIND	100B

PROPS CONTROLLER

LED OR DRIVER	BIT	OUTPUT OR FUNCTION	WIRE COLOR AND STAGE
1	42B	STAGE LEFT TURNTABLE	BROWN- SL
2	46B	RABBIT EARS TOP LEFT	RED- SL
3	47B	RABBIT EARS TOP RIGHT	ORANGE-SL
4	48B	RABBIT EARS BOTTOM LEFT	YELLOW-SL
5	49B	RABBIT EARS BOTTOM RIGHT	GREEN- SL
6	45B	SPEAKER LEFT	YELLOW-CTR
7	61B	SPEAKER RIGHT	GREEN- CTR
8	58B	STAGE LEFT CURTAIN	ORANGE-CTR
9	60B	CENTER STAGE CURTAIN	RED- CTR
10	59B	STAGE RIGHT CURTAIN	BROWN- CTR
11	41B	STAGE RIGHT TURNTABLE	RED- SR
12	43B	BBEAR WINDOW	WHITE- SR
13	44B	COCONUT DROP	GREEN- SR
14	82B	NOT USED KARAOKE SPOT	
15	83B	NOT USED APPLAUSE	
16	84B	NOT USED	
17	89B	NOT USED	
18	90B	NOT USED	
19	91B	NOT USED	
20	92B	NOT USED	

CHECK THESE WIRE BY LOCKING THE MOVEMENTS ON FOR THAT MOVEMENT AND CONNECT THE WIRE TO THE TERMINAL. IF THAT IS NOT THE CORRECT WIRE THEN TRY ANOTHER ON THAT CABLE. ALL THE BLACK WIRES FROM EACH CABLE (SL,CTR,SR) SHOULD BE CONNECTED TO ONE OF THE +24V COMMONS ON THE INTERFACE BOARD.

LIGHT CONTROL PROM

LED OR DRIVER	BIT	OUTPUT OR FUNCTION
1	106B	NOTE #1
2	107B	NOTE #2
3	108B	ROCKAFIRE NEON
4	119B	NOTE #3
5	56B	EXPLOSION NEON
6	109B	WHITE CIRCLE- GREEN GEL
7	110B	HEART- BLUE GEL
8	111B	TOP LEFT SPEAKER- PURPLE GEL
9	112B	TOP RIGHT SPEAKER- YELLOW GEL
10	113B	EQ. RACK- BLUE GEL
11	114B	BOTTOM RIGHT SPEAKER- PURPLE GEL
12	115B	YELLOW STAR- RED GEL
13	116B	BOTTOM LEFT SPEAKER- BLUE GEL
14	117B	ORAGN- BLUE GEL
15	57B	STAGE RIGHT FLOOR SPOTS
16	74B	STAGE LEFT FLOOR SPOTS
17	101B	STAGE LEFT SPOT
18	102B	STAGE RIGHT SPOT
19	103B	CENTER STAGE LEFT SPOT
20	104B	CENTER STAGE CENTER SPOT
21	105B	CENTER STAGE RIGHT SPOT
22	118B	NOTE #4
23	97B	LOONEY BIRD LIGHT
24	98B	DOOK WINDOW

POSITION OF COLOR LIGHTS FOR STAGE

CIRCUITS 1-4 ARE TO BE PLACED IN A LINE ABOUT 3 FEET FROM THE FRONT OF THE STAGE. NUMBER ONE TO BE ON THE STAGE LEFT END AND NUMBER 4 ON THE STAGE RIGHT END. CIRCUITS 5-9 ARE TO BE PLACED IN A LINE ABOUT 6 FEET FROM THE FRONT OF THE STAGE WITH 5 ON THE LEFT AND 9 ON THE RIGHT. THEY ARE TO BE DIRECTED AS FOLLOWS:

#1 TO THE CENTER WHITE CIRCLE OF BACK WALL	- GREEN GEL
#2 TO THE HEART ON THE WALL	- BLUE GEL
#3 TO THE TOP LEFT SPEAKER	- PURPLE GEL
#4 TO THE TOP RIGHT SPEAKER	- YELLOW GEL
#5 TO THE EQ RACK ON STAGE LEFT	- BLUE GEL
#6 TO THE BOTTOM RIGHT SPEAKER	- PURPLE GEL
#7 TO THE YELLOW STAR ON THE BACK WALL	- RED GEL
#8 TO THE BOTTOM LEFT SPEAKER	- BLUE GEL
#9 TO THE ORGAN ON STAGE RIGHT	- BLUE GEL

SIDE STAGE GELS ARE TO BE YELLOW ON STAGE RIGHT AND BLUE ON STAGE LEFT. THEY SHOULD BE MOUNTED DIRECTLY ABOVE SIDE STAGES AND POINTED SO HAS TO FILL AS MUCH OF THE STAGE AS POSSIBLE.

STROBE SHOULD BE MOUNTED IN THE MIDDLE OF CENTER STAGE AND WIRED TO THE TURNTABLE BOARD WITH A HOT LINE FOR POWER FEED.

NEON AND NOTES CAN BE PLUGGED INTO A TWO AND FOUR GANG BOX AND WIRED TO THE LIGHT CONTROLLER.

SPOTLIGHTS (1-5) SHOULD BE WIRED TO THE CONTROLLER WITH 5 HOTS, 3 NEUTRALS AND ONE GROUND. IRIS PLATES SHOULD BE DRILLED AFTER MOUNTING AND FOCUSING LIGHTS.

BEFORE THIS PAGE
IS OLD STUFF

AFTER THIS PAGE IS
WHAT LITTLE I HAVE PUT
TOGETHER REGARDING THE
LARGE TURNTABLE AND THE
AUDIO RACK - THERE IS SO
MUCH MORE TO DO!

DAVID

LARGE TURNTABLE

The large turntable (center stage) functions similarly to the character turntables, yet on a much larger scale. The turntable carries the three center stage characters - Billy Bob, Fatz, and Mitzi. Suspended beneath the turntable midway between Billy Bob and Mitzi is the main harness that provides air and electrical power to the turning table. This harness is shown in dashed lines in the diagrams that follow this section.

The table is turned by a large air motor located on the back of the stage. Mounted to the air motor shaft is a drive wheel and tire that runs on diamond plate attached to the perimeter of the turntable. To keep the tire from slipping on the diamond plate, there is an air cylinder that presses the motor/tire assembly against the diamond plate. There is a small, adjustable pressure regulator with a gauge attached to the cylinder itself. The pressure gauge should read 40 to 50 p.s.i. when the show is running.

Under the center of the turntable is the steel pedestal that supports much of the table's weight and houses the main shaft and bearings on which the table spins. On the pedestal is a small sprocket. Mounted on one of the spokes of the turntable is a shaft with a larger sprocket (feedback gear). The two sprockets are attached by chain. When the turntable spins, the feedback gear is turned accordingly. The feedback gear has many sets of holes that, as it turns, pass between two circuit boards. Mounted on one board are infrared light emitters; mounted on the other board are infrared collectors. With everything properly aligned, the holes pass directly between the emitters and collectors. There are 31 different combinations of holes. Consequently, by monitoring the infrared boards, the computer knows where the turntable is and, when turning, which direction it is traveling, and when to stop.

These sprockets are preset at the factory and should never need adjustment; however, there are a couple areas of concern that should be fully understood by the store technician. The diagrams after this section will help clarify the following information regarding the travel "limits" of the large turntable.

As shown in diagram 4A, when the computer sends the table fully clockwise, Billy Bob is front and center. As shown in diagram 4B, when the table is sent fully counterclockwise, Billy Bob travels beyond the front-center position and ends up closer to the big screen TV. During a show, whenever the computer sends the table to a new location, it knows that there will be a certain amount of drift (coasting) after the air motor is shut off; consequently, the motor is shut off a fraction of a second early so the turntable coasts to a stop at or very near the

desired location. As you can imagine, if the turntable speed (as defined under the UTILITIES section) is too fast, it will coast much too far and go beyond the target location; too slow, and the table won't even reach the target location. It's your responsibility, as with the character turntables, to check the large turntable speed regularly.

IMPORTANT: The large turntable DOES NOT have a mechanical stop mechanism to prevent the table from going beyond the extreme clockwise position or extreme counterclockwise position. Instead the table is equipped with a limit switch that, when triggered, immediately shuts off all air to the large turntable motor and temporarily "kills" the large table, meaning it will no longer move at all on its own. This limit switch is mounted on the aluminum stage spoke next to the feedback gear shaft. There is a pin extending from the feedback gear shaft that comes in contact with the limit switch if the table travels too far in either direction. IF the table is traveling too fast and/or, for any other reason, the table travels too far in either direction, the limit switch will be triggered and the air motor shut down. In such event, it is critically important that the following procedures be used to correct the situation:

Step 1) DO NOT allow any unqualified person to touch the turntable, e.g., a customer or employee that thinks giving the stage a "push" will fix the problem. In all likelihood, the problem will be compounded instead of cured. Please make sure that there is a "hands off" policy in place for this unlikely event.

Step 2) YOU MUST determine which direction the table was traveling when the limit switch was impacted. This is done by noting two factors. First, where is Billy Bob located and, second, which way is the main harness wrapped around the pedestal? These can be easily determined by comparing your stage to the diagrams 4C and 4D. Diagram 4C shows the approximate locations of Billy Bob and the harness if the table traveled too far clockwise. Diagram 4D shows the approximate locations when the table travels too far counterclockwise. DO NOT rely on Billy Bob's location alone. ALWAYS check the location of the main harness too, as it will ALWAYS TELL THE TRUTH. (NOTE: If the locations of your Billy Bob and the main harness DON'T resemble one of the two diagrams (4C and 4D), proceed directly to the next section entitled "LARGE TURNTABLE SYNC PROBLEM ?"). *(Not written yet)*

Step 3) If the turntable has gone too far clockwise, push the turntable counterclockwise until Billy Bob is over near to the big screen TV. This puts the table well into the normal operating area and moves the pin off of the limit switch, returning air pressure to the motor. Next, press the RESET button on the Big Important Board (RESET is described in the OPERATING SYSTEM section). *(Not written yet)*

If the stage has gone too far counterclockwise, push the turntable clockwise until Billy Bob is roughly front and center. This puts the table well into the normal operating area and resets the limit switch, returning air pressure to the motor. Next, press the RESET button on the Big Important Board.

CAUTION: If the stage is manually pushed the WRONG way in error, the pin that contacts the limit switch will eventually go completely PAST the limit switch, allowing the switch to reset which restores air pressure to the motor. If this happens, the relationship between the turntable and the feedback gear (which tells the computer where the table is) is now completely out of sync. ("sync" is short for synchronization.) When the show runs, the large table will likely turn, BUT the characters will always be facing in a direction they shouldn't be. Another problem, even more important, is that the main harness can get wrapped MORE than once around the pedestal - a situation that can cause SEVERE damage to the harness and turntable (see LARGE TURNTABLE SYNC PROBLEM ?).

Step 4) In any case, when the RESET button is pressed, the large turntable will turn counterclockwise until it finds the first set of readable holes on the feedback gear. If this search for holes takes longer than about 1 second, the table will reverse and begin turning to the right until it finds a readable location. (The character turntables will be resetting at the same time). When the computer is satisfied that the table is "reset," everything stops moving and the show is ready to run.

Step 5) When the show is running again, note the location of the characters. If they are not where they should be and are facing the wrong direction, the large turntable is out of sync. See LARGE TURNTABLE SYNC PROBLEM ? section.

DIAGRAM 4A

Billy Bob is front and center.

Main harness is partially wrapped around the pedestal as shown.

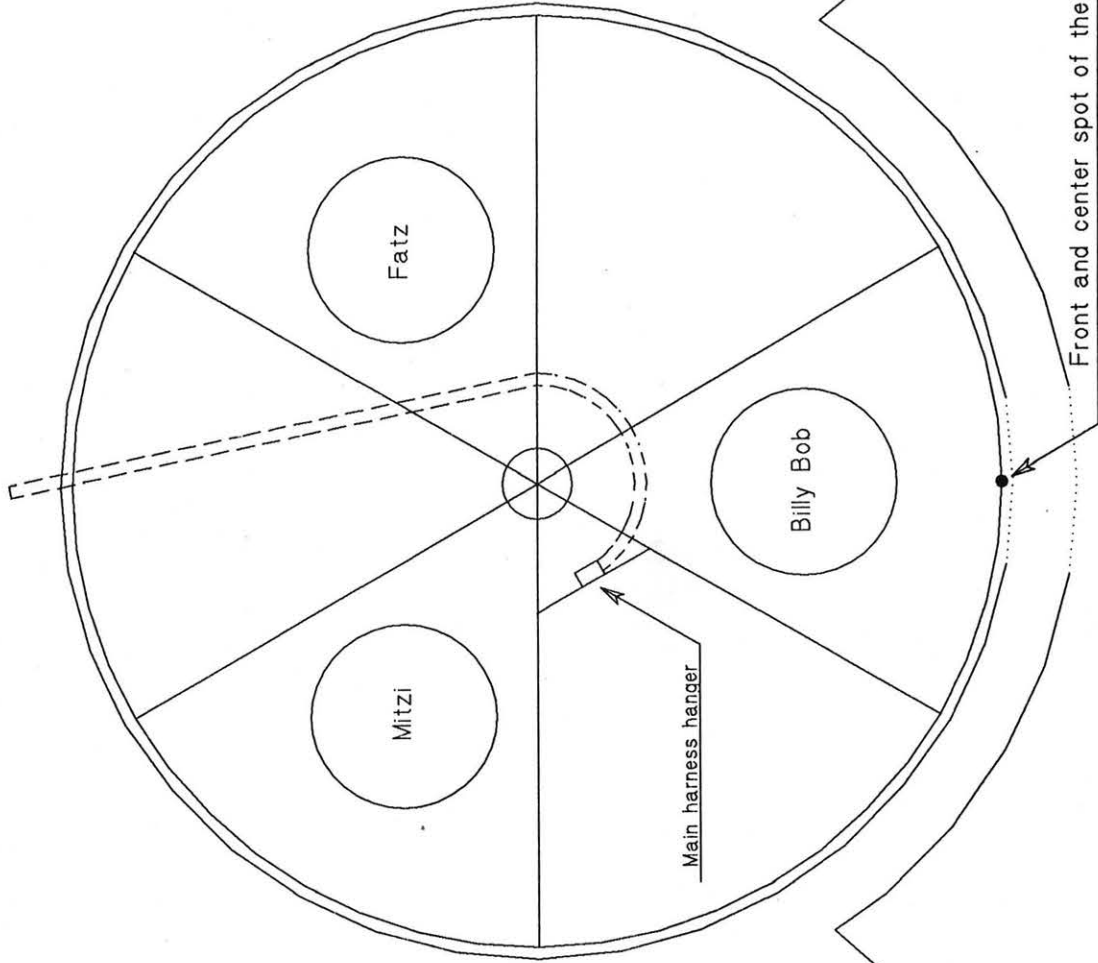

Title: Fully clockwise position

Date: 04/15/95

Scale: Representational

Tolerance (unless indicated):

Creative Engineering, Inc.
47 West Jefferson Street
Orlando, Florida 32801

DIAGRAM 4B

Billy Bob is close to the large screen TV.

Main harness is partially wrapped around the pedestal as shown.

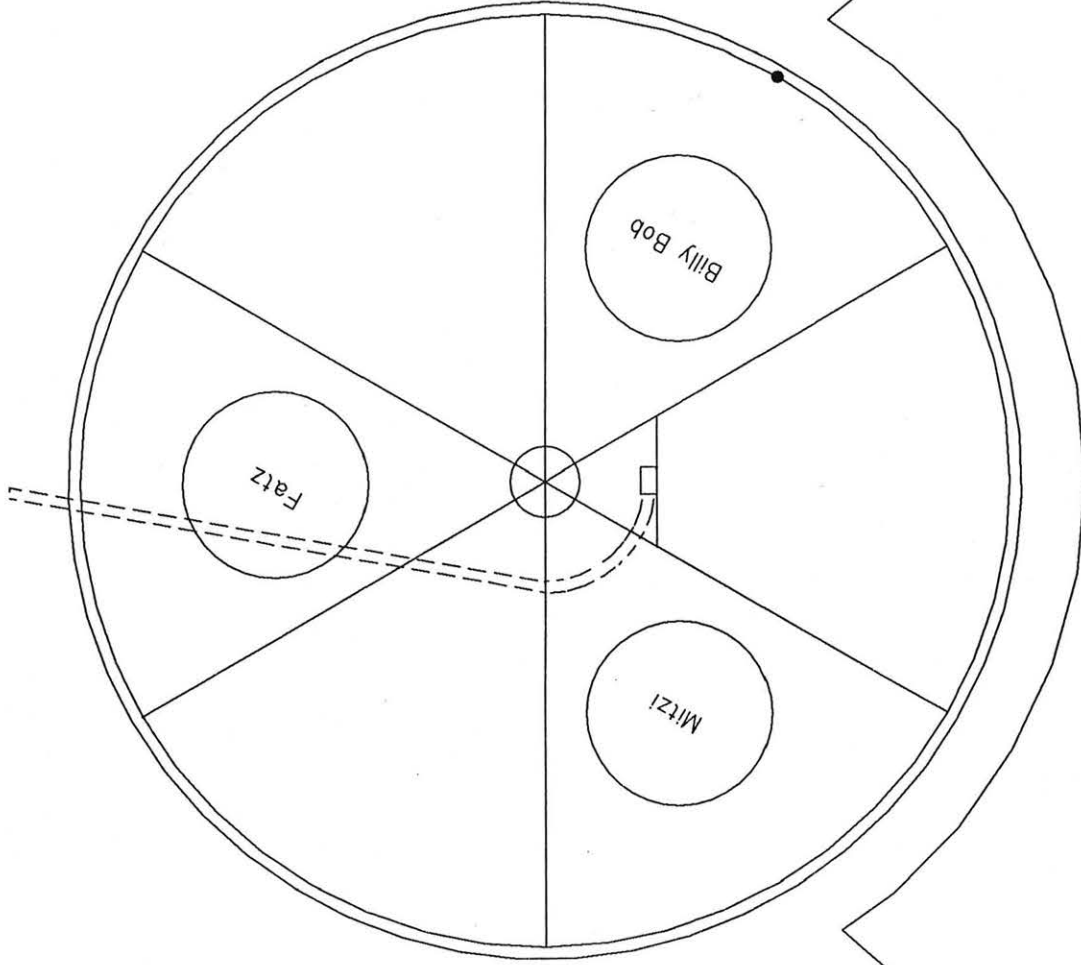

Title: Fully counterclockwise position

Date: 04/15/95

Scale: Representational

Tolerance (unless indicated):

Creative Engineering, Inc.
47 West Jefferson Street
Orlando, Florida 32801

DIAGRAM 4C

Turntable is beyond the normal extreme clockwise position.

Main harness is partially wrapped around the pedestal as shown.

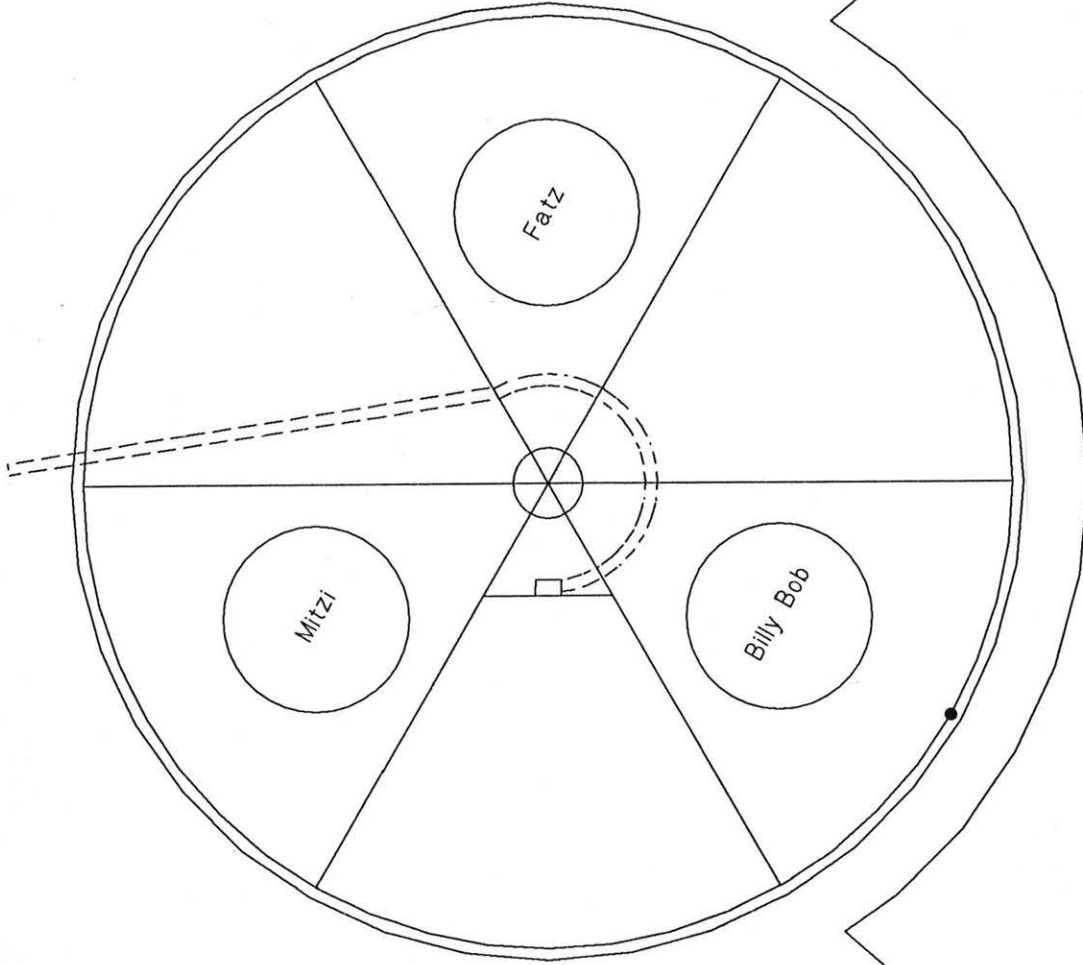

Title: Beyond fully clockwise position, limit switch triggered

Date: 04/15/95

Scale: Representational

Tolerance (unless indicated):

Creative Engineering, Inc.
47 West Jefferson Street
Orlando, Florida 32801

DIAGRAM 4D

Turntable is beyond the normal extreme counterclockwise position.

Main harness is partially wrapped around the pedestal as shown.

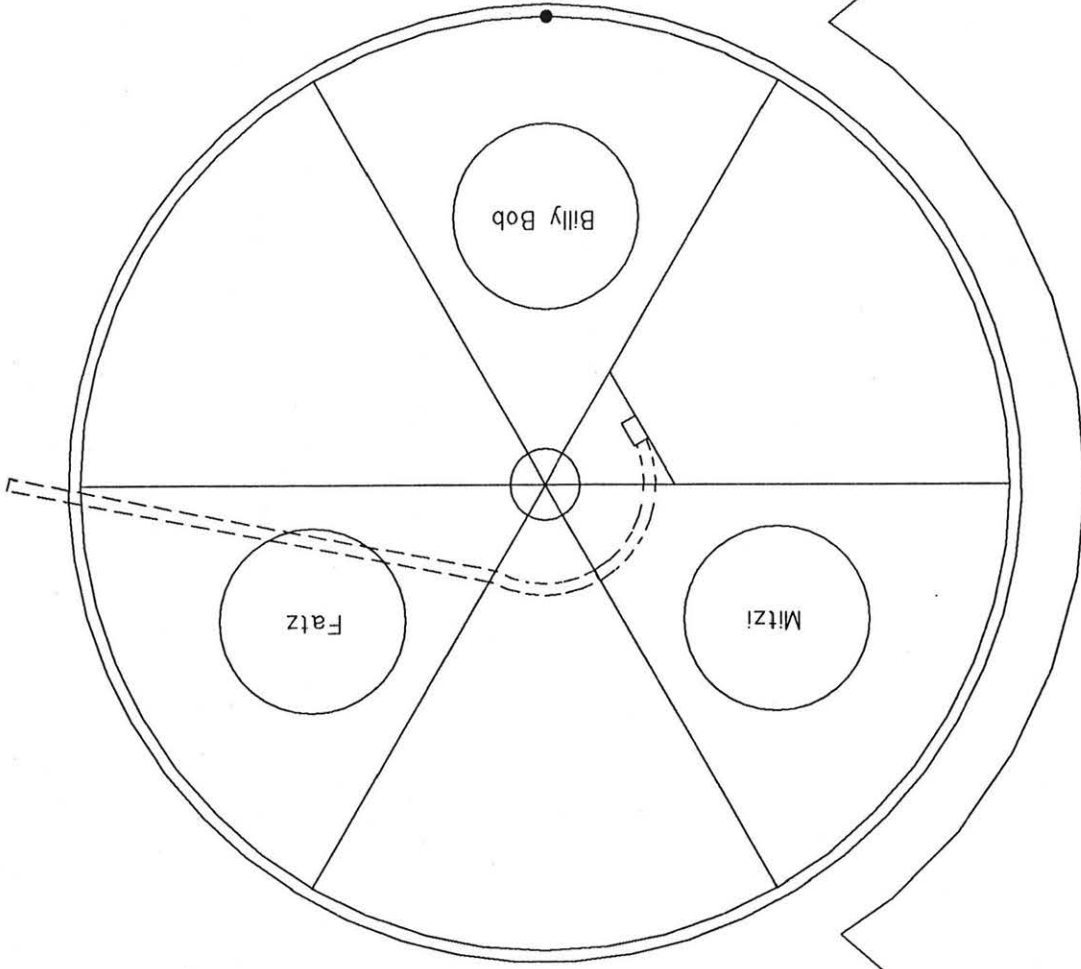

Title: Beyond fully counterclockwise position, limit switch triggered

Date: 04/15/95

Scale: Representational

Tolerance (unless indicated):

Creative Engineering, Inc.
47 West Jefferson Street
Orlando, Florida 32801

AUDIO / CONTROL

RACK

Audio / Control Rack

04/09/95

NOTE: Two items not visible from the front of the rack are the Yamaha PN90 Crossover and the Line Summing Amp. These two units are accessible from the rear of the rack.

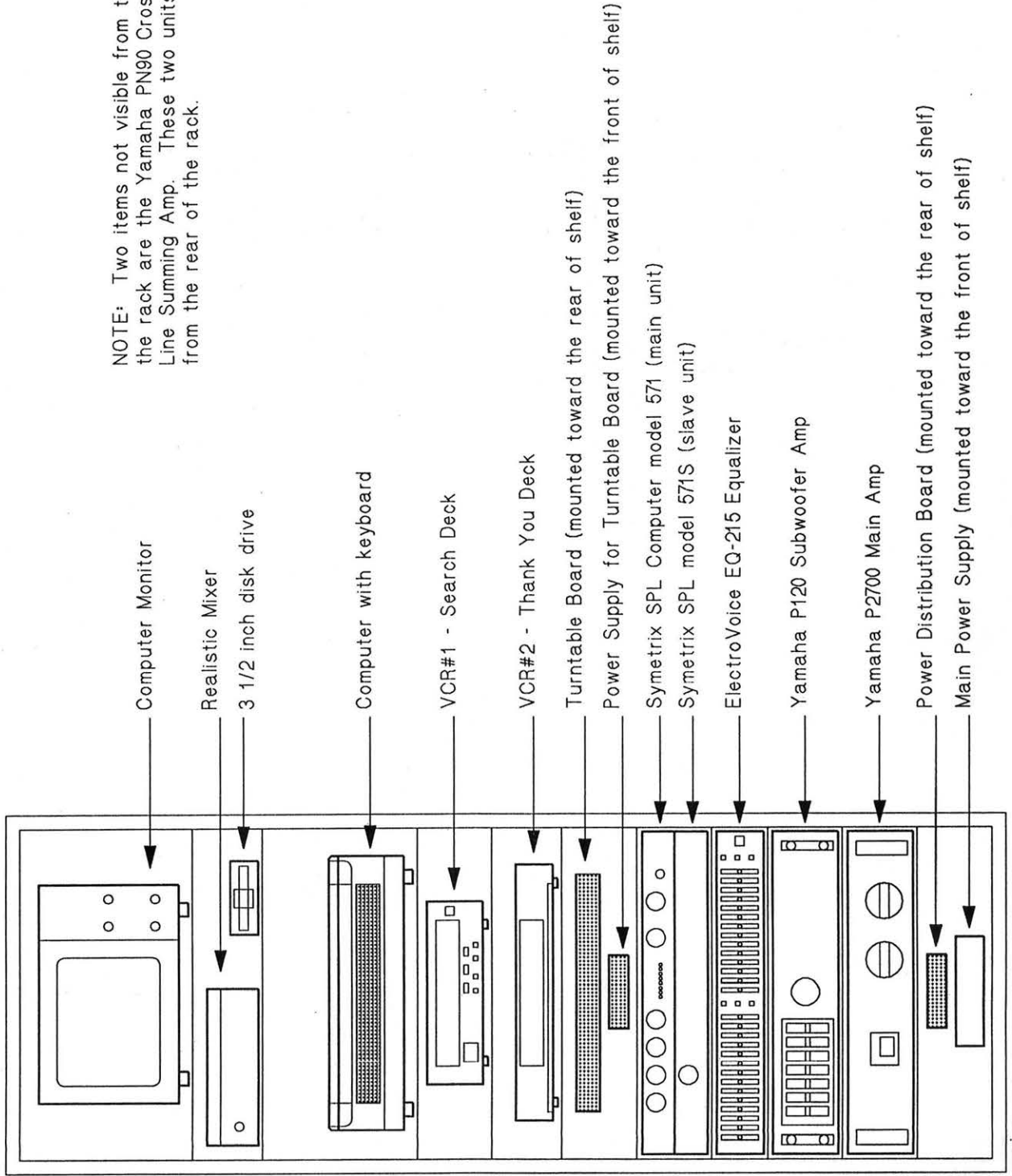

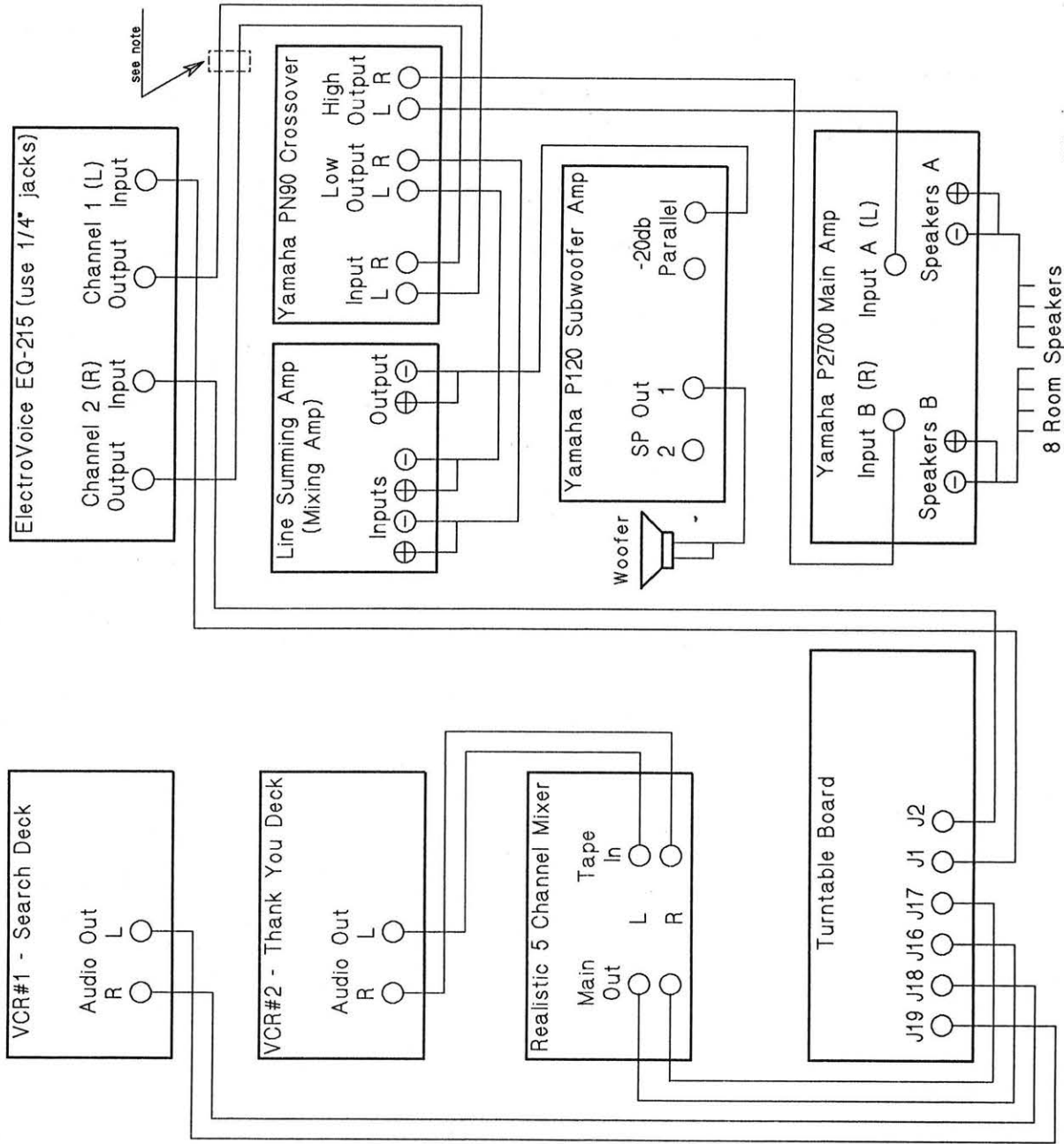

NOTE: If equipped, the SPL Computer goes in-line where indicated with

In the audio path, the SPL Computer goes directly before the Yamaha PN90 Crossover.
 For shows WITH Karaoke, the outputs from the TEAC Model 1 Mixer go to the SPL Computer and the outputs from the SPL Computer then go on to the PN90 Crossover.
 For shows WITHOUT Karaoke, the outputs from the EQ-215 Equalizer go to the SPL Computer and the outputs from the SPL Computer then go on to the PN90 Crossover.

- Format buttons must be in the "out" position for Music
- Sense Mic 1 is required - Sense Mic 2 is optional.

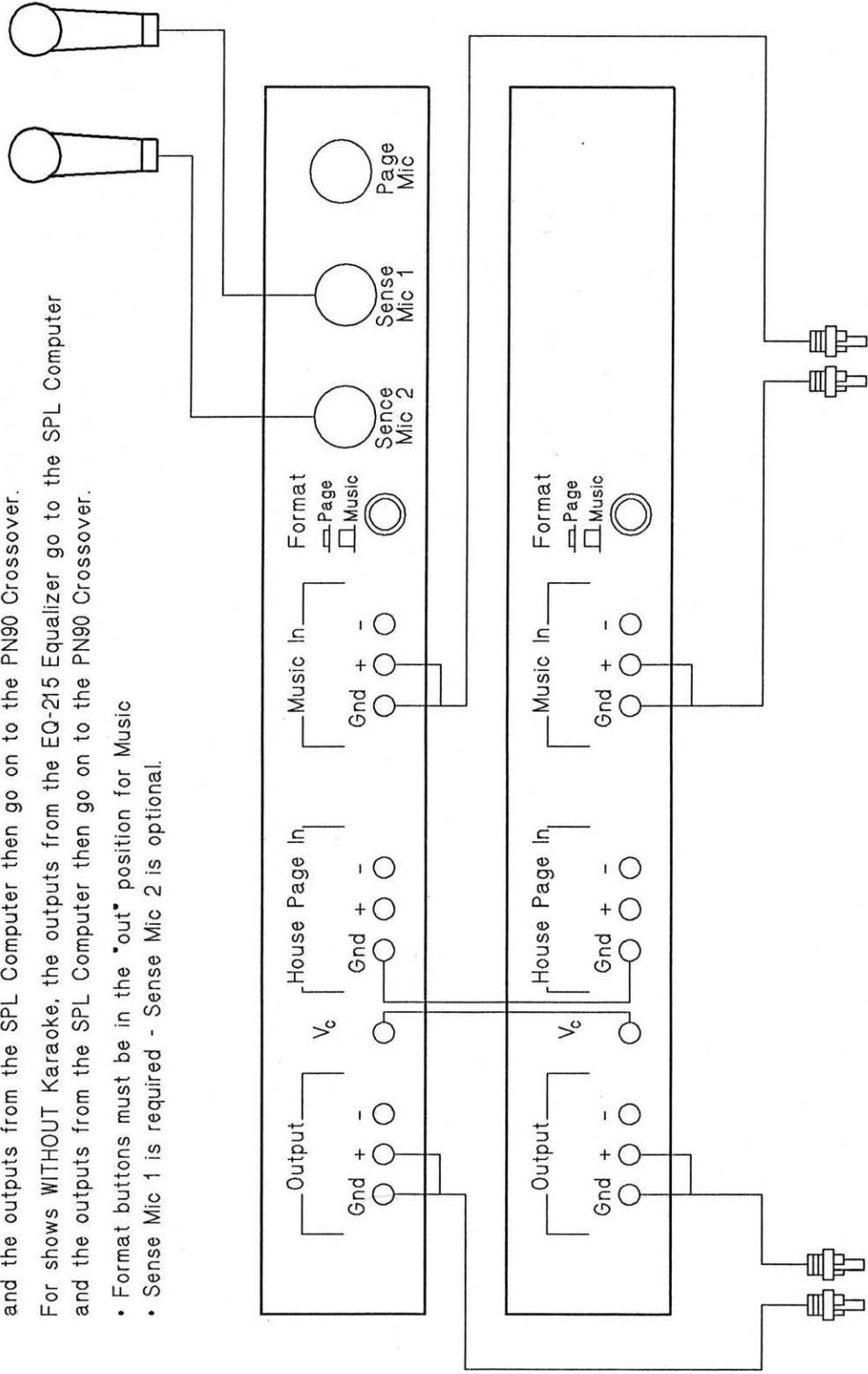

To inputs on PN90 Crossover

From outputs on Equalizer
 (or from TEAC Model 1 mixer on Karaoke shows)

GENERAL DESCRIPTION

This introductory section is designed to take you on a quick tour of the show - from the VCR's and computer to the valve banks, air motors, lights, and props. The rest of the sections are devoted to specific areas of the show.

After following the start up procedure at the end of this section, the show is ready to play. In general, here's how all the computerized components of the show work:

The heart of the system is the computer (currently a modified Apple). The computer programs and cards do most of the decision-making while a show is running. For example, on a full show with Show Selector, the computer would do all the following: decide which song to play via the selector panels; instruct the appropriate VCR to play the show; decode the show data from the VCR video; send show data to the characters, turntables, and props; control time-outs between shows and the frequency of replays; and much more. In addition, in the utilities mode, the computer can perform dozens of diagnostic tests, manually cycle any movement of the show, and even send and receive e-mail with the optional modem. The computer is the central interpreter that synchronizes all the other components of the show.

All of the show information is contained on the video tapes - the video, the stereo audio, and the control data (encoded in the video). There are two VCR decks used for most shows. The first deck is a professional RS-232 controllable "search deck" (currently, a Panasonic). There are two key features of this deck, the first being the RS-232 connection between the deck and the RS-232 card in slot #4 of the computer. This connection gives the computer direct and complete control over the VCR deck. The other key feature is the internal counter that tracks the exact position of the tape and can be accessed by the computer, i.e., the computer tells the VCR to "go to" a particular spot on the tape (the beginning of the selected show), and the deck automatically rewinds or fast-forwards to that exact position. (A show with neither Show Selector nor Karaoke would not have this search deck.)

The second VCR deck is a commercial-grade deck with a standard remote control unit that has been wired to the Big Important Board (described later). For most shows, this deck is called the "thank you" deck because it's duty is to play a short skit before each actual show is played from the search deck. The thank you shorts are played back sequentially one at a time until the last one is played, at which point the tape is rewound to the beginning. The play, stop, and rewind commands come from the computer via the remote control. If it was possible to get a

quality commercial-grade deck with a remote jack on the back, we would certainly use it; however, the days of "wireless" remotes are here to stay, so no one makes a deck with a "wired" remote jack anymore. Just as you would with a home VCR, please keep the remote transmitter and the VCR's dust-free to ensure trouble-free operation. (A show with neither Show Selector nor Karaoke would ONLY have this deck.)

From the video decks, the video and audio travel different directions (refer to the wiring diagram in the COMPUTER / WIRING DIAGRAM section while reading the information below):

VIDEO SIGNALS:

The video from both decks goes into two input jacks on the Video Decoder card in slot #1 of the computer. The Decoder separates the show control data (described below) from the video itself. The video is then sent on to the Big Important Board (BIB). The BIB, according to the programming, amplifies the signal and controls when the signal is then allowed to be sent back out to the TV(s). (Shows with Karaoke work a bit differently - see the BIG IMPORTANT BOARD section and the wiring diagram.)

SHOW CONTROL DATA:

The show control data leaves the computer at two output jacks on the keyboard-end of the Showplay card in slot #2 of the computer. The top output is referred to as the "top drawer" signal, the bottom as the "bottom drawer" signal (a throwback to a much older version of a computer that was housed in a small gray cabinet that literally has two drawers). The top drawer signal goes directly to Dook's bit-stripper, then on to the Large Turntable Interface Board where it splits off to supply show data to Billy Bob's, Fatz's, and Mitzi's bit-strippers. The bottom drawer signal goes to the BIB which has its own bit-stripper on board to collect the specific data necessary to control the large turntable, character turntables, and strobe light. The signal then leaves the BIB and continues on to the panel box that houses the lighting and props bit-strippers. From there, the signal passes to Looney Bird's bit-stripper and on to Beach Bear's bit-stripper. (Lite shows do not have Dook, Looney Bird, or Beach Bear.)

BIT-STRIPPER - The bit-stripper system consists of several individual boards (mentioned above), each having a particular set of functions. Each character of the show has its own bit-stripper board. The props and lights each have a bit-stripper board as well. (The exception is the bit-stripper circuitry for the turntables and strobe light which is integrated on the BIB.) These bit-stripper boards are nearly identical except for the 6801 processor that is programmed to make each board specific to its task (the lighting board is slightly modified).

Character bit-stripper boards use the show data to shift the individual 24vdc valves of the valve bank that control all the pneumatic movements of the character. Character boards also have a 6805 PROM to control the 5vdc electric servo motors that operate the eyes and eyelids. The props bit-stripper board essentially works the same way by shifting the 24vdc pneumatic valves that control the curtain(s) and side turntable props (if equipped).

On each bit-stripper is a line of LED's that indicate when a movement is ON. When the LED is lit, the controlled movement is ON. The LED's, in order (starting near the edge of the board), represent the following:

- LED # 01-21 pneumatic movements associated with that bit-stripper, e.g., LED #1 on a character is the mouth.
- LED # 22-27 servo movements on characters
- LED # 28 not used
- LED # 29-30 connected in parallel, these two LED's indicate when the board is accurately interpreting the show data from the computer - a condition referred to as "in sync." When the LED's are NOT lit, the board is in sync. If the LED's ARE lit, the board is not in sync and will not operate properly.

The lighting bit-stripper board uses the show data to switch the 24vdc inputs on the solid-state relays to close the high voltage side of the relays to power the lights. On the lighting bit-stripper, the LED's #01-24 represent the first 24 solid-state relays in the lighting controller (described in PROPS / LIGHTS section). As with all bit-strippers, LED's 29-30 are for indicating sync.

AUDIO SIGNALS:

The stereo audio leaves the VCR's and goes directly to the BIB at four input jacks (two for each VCR). The BIB determines which deck is in play, and passes that audio (left and right channels) out the two output jacks to the equalizer. From there, the audio goes to the SPL computer (if equipped), then to the crossover device which separates the lows-frequency tones from the high-frequency tones. The "lows" go to the mixing amp that combines both channels to mono, and then on to the subwoofer amp that drives the bass speaker under the stage, behind the front grill. The "highs" go directly to the main amp that drives the eight monitor speakers placed around the room (see the audio system diagram).

ANIMATION:

The animated components are in, basically, three different groups: character movements, props, and turntables.

CHARACTER MOVEMENTS - The eyes and eyelids of each character are controlled by electric servo motors (servos), while all other movements are pneumatically operated. The pneumatic movements are all controlled by the valve bank mounted underneath or behind each character. The valves are shifted (energized/de-energized) by the bit-stripper board according to the show control data. For example, when the *right arm raise* valve is energized, the arm raises; when de-energized, the arm returns to its starting position. Most character movements are actuated by air cylinders that extend and retract, while others use rotary actuators that rotate up to 90 degrees.

PROPS - Props are all other pneumatic movements outside of the characters. These movements include (on a full show) rabbit ears, imitation speakers, coconut drop, Beach Bear's window, computer swivel, curtains, and side turntables. The reason side turntables are on this list is because they are moved by an air cylinder and are controlled by "props" valve banks; however, side turntables are discussed separately from the props in the manual sections due to their unique air-over-oil design.

TURNTABLES - The center stage has one large turntable on which the center-stage characters travel, and each center-stage character is on its own, smaller turntable. These four turntables operate essentially the same way - each is moved by an independent air motor, each can be moved independently of the others, and each has an independent "feedback" unit to tell the computer system its current position and its direction of travel (when moving).

**** The above general information is just that - general. ****

**** Detailed information follows in separate sections. ****

**** Do yourself a favor - read it! ****

**** Questions? Call 407-425-1001 ****

START UP / SHUT DOWN

START UP PROCEDURE FOR ROCK-AFIRE SHOW

- 1) Turn on all circuit breakers for show.
- 2) Turn on compressor system.
- 3) Turn on sound system from top down (EQ, then amps).
- 4) Turn on computer monitor.
- 5) Insert Show disk, and turn on computer.
- 6) Turn on VCR and make sure the tape is loaded.
- 7) To start show control system, press button labeled:
PRESS HERE TO START SHOW PLAY.

SHUT DOWN PROCEDURE FOR ROCK-AFIRE SHOW

- 1) Turn off computer.
- 2) Turn off sound system from bottom up (amps, then EQ).
- 3) Turn off all circuit breakers.
- 4) Turn off compressor system.
- 5) System is now off.

AUDIO / CONTROL RACK

The items in the rack are shown in the diagram at the end of the section. Following that is another diagram that shows the audio path of the entire show. The following information is a shelf-by-shelf, general description of the components.

MONITOR - The monitor is monochrome and is subject to screen burn-in, so you are encouraged to keep either the contrast or brightness control set to minimum when the monitor is not being utilized. Some program prompts require the lightpen for making selections; therefore, you will have to make sure the contrast and brightness controls are set high enough for the lightpen to work properly. (When you're all done, darken the screen again.)
NOTE: There is no audio signal sent to the monitor.

AUDIO AMPLIFIER - This is a low-power audio unit (make and model may vary) used to match the volume of the audio of the Thank You deck to that of the Search deck. Audio levels are carefully controlled during recording, but slight level differences may be experienced due to differences in the VCR's themselves.

DISK DRIVE - A high density (1.44 Meg) drive that uses specially formatted disks supplied by Creative Engineering, Inc.
CAUTION: Do not attempt to copy a C.E.I. disk on a standard PC - it won't work!

COMPUTER - (See the COMPUTER / WIRING DIAGRAMS section)

SEARCH DECK (VCR #1) - Professional-grade, addressable search deck that is controlled directly and completely by the computer via the RS-232 cable between them. This deck, which plays the show tape, can locate the exact beginning point of any show/song according to the indexing information on the accompanying show disk. Shows with neither Show Selector nor Karaoke will not have this deck.

THANK YOU DECK (VCR #2) - Commercial-grade VCR controlled by the wired remote control to play a "Thank You [for pressing a button on the Show Selector]" skit prior to each show. Shows with Karaoke but no Show Selector will not have this deck. On shows with neither Show Selector nor Karaoke, this will be the only deck in the rack and will not play "thank you" skits as it will contain the sequentially played shows themselves.

BIG IMPORTANT BOARD - (See BIG IMPORTANT BOARD section)

SPL COMPUTER (Sound Pressure Leveling) - If equipped with your show, its purpose is to automatically adjust the volume of the audio according to background noise. If the area directly immediate to the show experiences extreme fluctuations in background noise, an SPL computer can appropriately balance the audio level to the noise.

EQUALIZER - In most circumstances, the equalizer should be kept flat (all levels at zero). If, however, you have specific experience in adjusting tones, make adjustments conservatively. Remember: what sounds specifically "good" to one person may not sound good to the general public. When in doubt, set the EQ flat.

SUBWOOFER AMP - Used to control the lowest bass tones, this amp powers the woofer behind the grill on the front of the stage. CAUTION: Adding too much bass can cause "rumbling" that will ruin the quality of the audio. Get more than one person's opinion to help set the levels in your room.

MAIN AMP - Used to control the volume level of the eight room speaker.

POWER SUPPLY - This the main DC power supply of the show that supplies the power for the valve banks, the lighting relays, the Big Important Board (24vdc only), and the infrared feedback circuitry.

Audio / Control Rack - with Manager Switch only

08/15/95

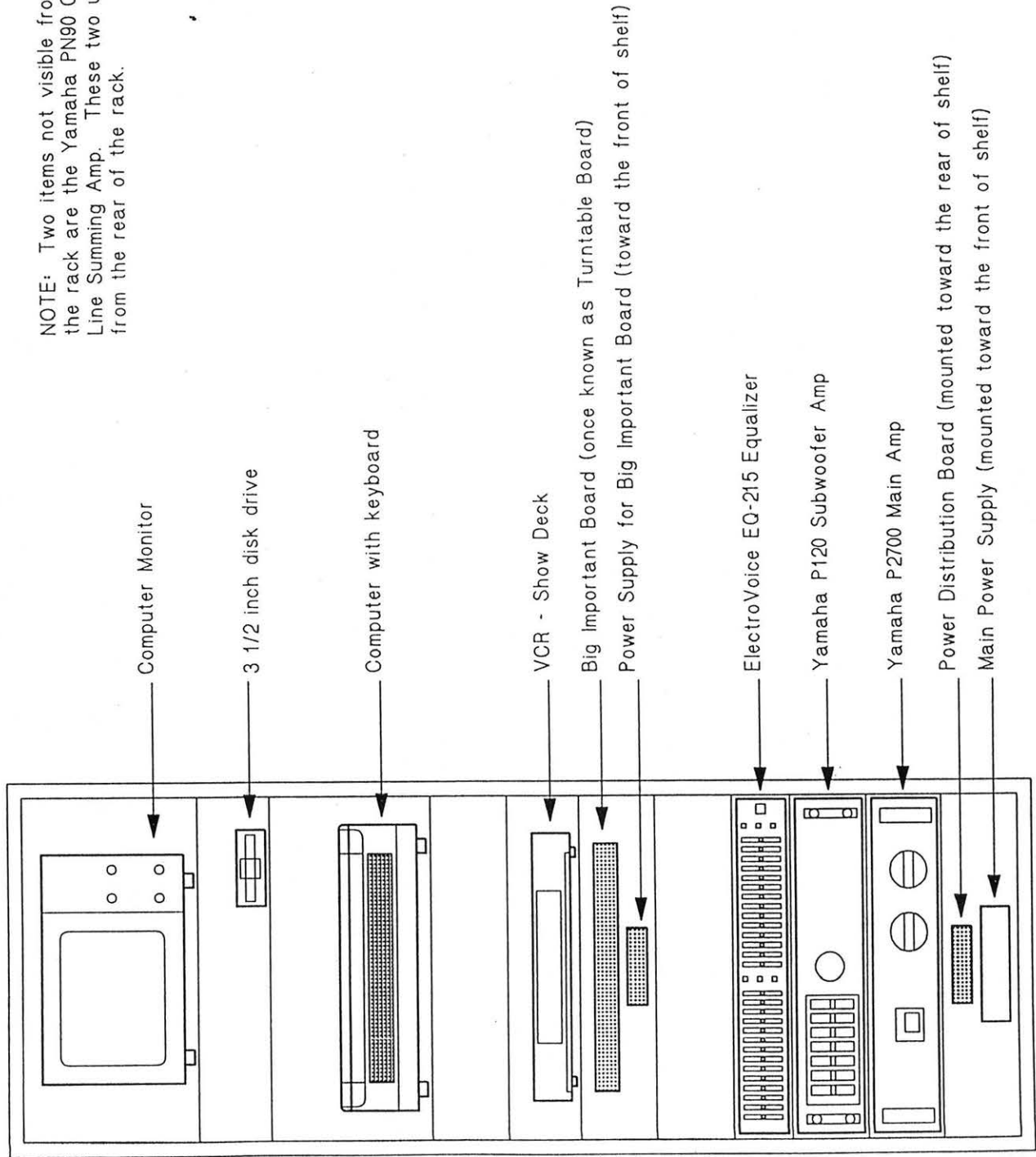

NOTE: Two items not visible from the front of the rack are the Yamaha PN90 Crossover and the Line Summing Amp. These two units are accessible from the rear of the rack.

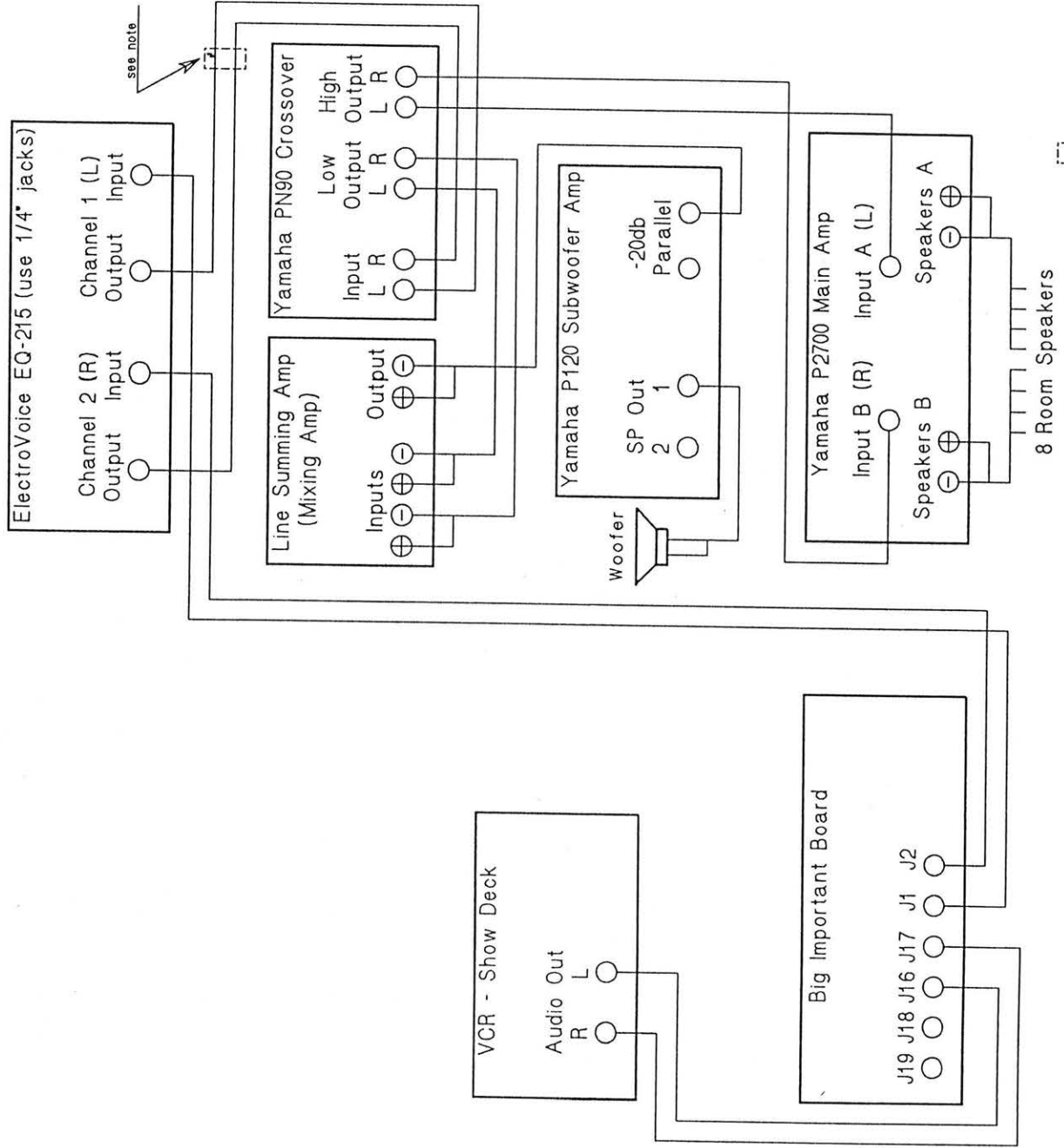

NOTE: If equipped, the SPL Computer goes in-line where indicated with []

COMPUTER / WIRING DIAGRAMS

There isn't much else than can actually be "said" about the computer itself that hasn't already been outlined in the GENERAL DESCRIPTION section. The computer is an Apple II+ or IIe that has been modified to work with the custom-made cards (boards in the slots) manufactured by Creative Engineering, Inc.

On the following page is a wiring diagram that shows the connections between the computer cards (boards) and the other components of the show.

GENERAL NOTES:

- 1) Keep the Caps Lock on at all times.
- 2) Keep at least one foot clearance behind the rack that holds the computer (to prevent heat build-up).
- 3) Keeping the monitor screen clean will help the lightpen work efficiently.
- 4) Protect the disks and drive from dust, and, as usual, don't ever expose the floppy disk itself (protected by the sliding metal door on the plastic disk casing).
- 5) Keep the lid ON the computer at all times. Leaving the lid off is far too dangerous - anything falling into the interior of the computer could do serious damage.
- 6) The computer has its own internal power supply that should last a few years, depending on how long the computer is on each day. If you have to replace the power supply, use the spare in the spare parts kit and reorder another spare. Without the computer, the show will not run.

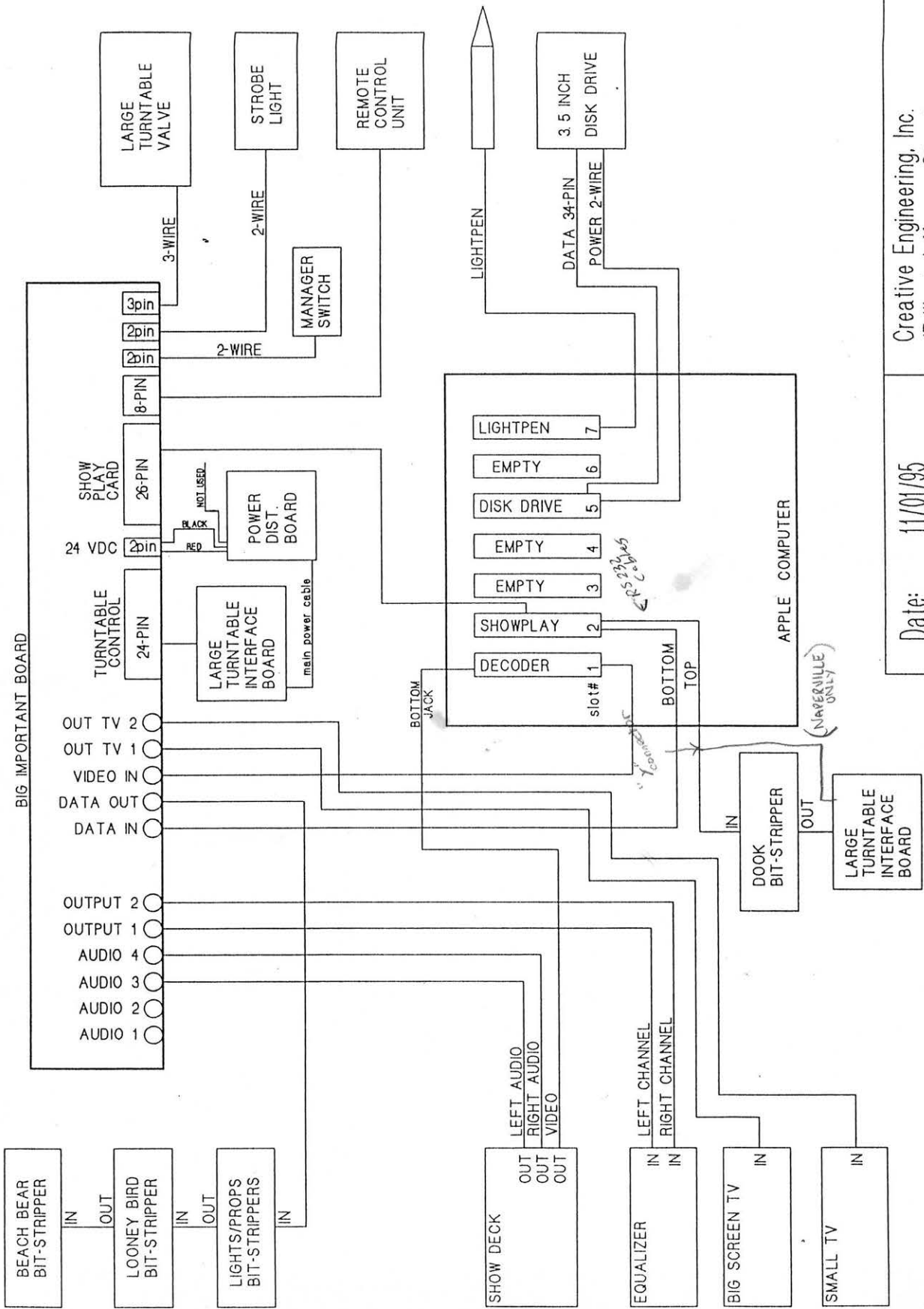

Creative Engineering, Inc.
 47 West Jefferson Street
 Orlando, Florida 32801

Date: 11/01/95

Title: Wiring diagram - Full show with Manager Switch only

BIG IMPORTANT BOARD

The Big Important Board (formerly known as the turntable board) is mounted on standoffs on a shelf in the audio rack, and is the most important (thus, the name) and most complex board in the entire system. The Big Important Board (BIB) and its connectors are shown in the diagram at the end of this section.

The BIB performs many functions, both on its own and in conjunction with the computer. These functions are:

- 1) Receives left and right audio channels from VCR(s) (jacks J19-J17), decides which is playing, and passes the audio out to the equalizer (jacks J1 & J2).
- 2) Collects show data from the computer's showplay card, sends it through the bit-stripper, and passes the signal on to the lights/props bit-strippers. The bit-stripper on the BIB strips out the showplay data necessary to control the large turntable, the three character turntables, and the strobe light.
- 3) Receives video signal from the computer's video decoder card, amplifies the signal, and sends it out to the large screen TV and Looney Bird TV (jacks J8-J10).

NOTE: For shows with Karaoke, jacks J8-J10 work differently. J8 receives the video signal, J10 receives the composite monitor signal from the computer, and J9 outputs whichever the BIB selects to the Karaoke TV.

- 4) Via the 24-pin connector, reads positioning information from the large turntable and character turntables, and controls the valves for the character turntable motors.
- 5) Operates the remote control for the commercial VCR.

NOTE: Your board may have an 8-pin connector for the remote instead of the original 6-pin as shown in diagrams. The other two pins supply the 5 volts that used to be picked up on the main power distribution board.

- 6) Receives Manager switch signal (if so equipped).
- 7) Controls the valve for the large turntable motor.

The power to the BIB is supplied by an independent power supply mounted on the same shelf and behind the BIB. There is a 6-pin jack on the BIB (J13) to accept the connector of the power supply. The pin layout is shown in the diagram in the DC POWER SUPPLY CIRCUITS section.

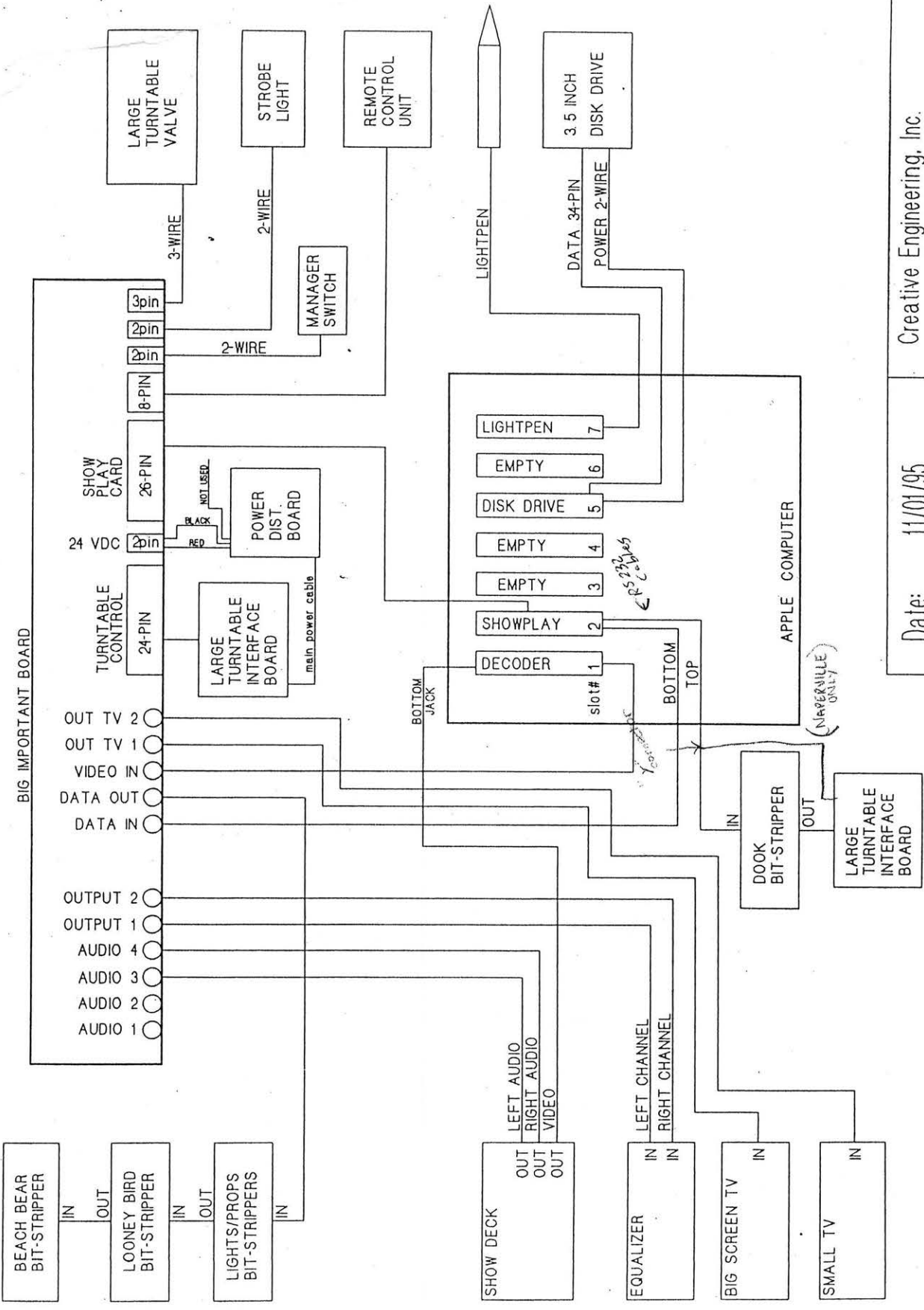

Creative Engineering, Inc.
 47 West Jefferson Street
 Orlando, Florida 32801

Date: 11/01/95

Title: Wiring diagram - Full show with Manager Switch only

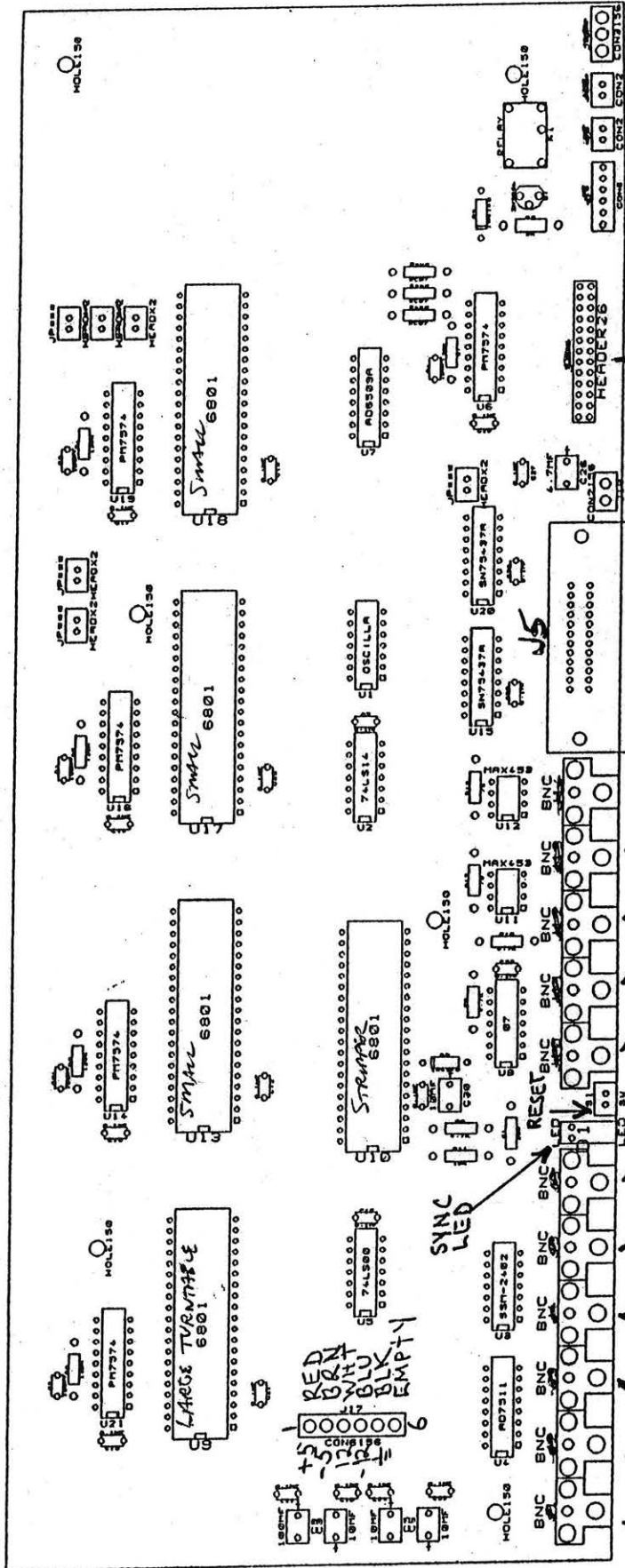

SEARCH DECK LEFT CHANNEL J19
 SEARCH DECK RIGHT CHANNEL J18
 THANK YOU DECK LEFT CHANNEL J16
 THANK YOU DECK RIGHT CHANNEL J17
 LEFT AMPLIFIER J1
 RIGHT AMPLIFIER J2
 SHOW DATA IN J6
 SHOW DATA OUT J7
 VIDEO IN FROM VIDEO DECODER J8
 SMALL TV J9
 BIG TV J10
 TURNTABLES CONNECTOR J5
 24VDC TO POWER DISTRIB. J14
 26-PIN RIBBON CABLE TO SHOW PLAY CARD J3
 REMOTE CONTROL CONNECTOR J12
 MGR SW. J11
 STROBE LIGHT J15
 CENT TURNTABLE MOTR J15

DC POWER SUPPLY CIRCUITS

There are two external power supplies used in the show, both mounted in the Audio/Control rack. The smaller power supply is directly behind the Big Important Board (BIB). Its sole purpose is to power the BIB. The larger main power supply, mounted on the bottom shelf behind the power distribution board, supplies all the other DC-powered components of the show.

NOTE: The BIB does get its 24vdc, used to control the large turntable motor valve, from the main power supply, via the power distribution board (see BIB section).

Both power supplies are designed specifically for the requirements of your show. Should one ever need to be replaced, you must replace it with an original from Creative Engineering to ensure proper operation and prevent damage to other components.

Included diagrams: BIB power supply
 Main Power Distribution
 Large Turntable Interface Board
 Limit Switch circuit

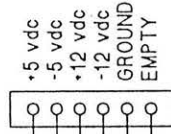
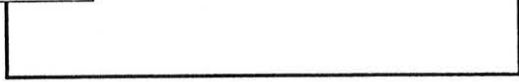
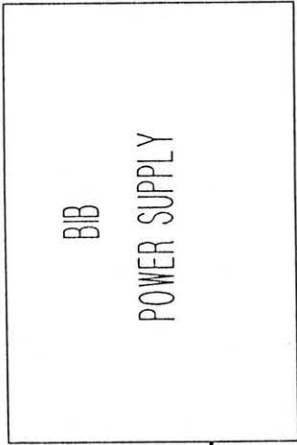

6-pin connector (size exaggerated)

BIG
IMPORTANT
BOARD

Title: BIB power supply

Date: 08/18/95

Scale: Representational

Tolerance (unless indicated):

Creative Engineering, Inc.
47 West Jefferson Street
Orlando, Florida 32801

- Wiring connections to this board are described, rather than illustrated, for the following reasons:
- 1) Jacks J1 and J9 are in parallel; therefore, connectors to them may be reversed.
 - 2) Jacks J2 through J8 are in parallel; therefore, connectors to all of them might be in any order.
 - 3) The ends of the cables are labeled to indicate their purpose.

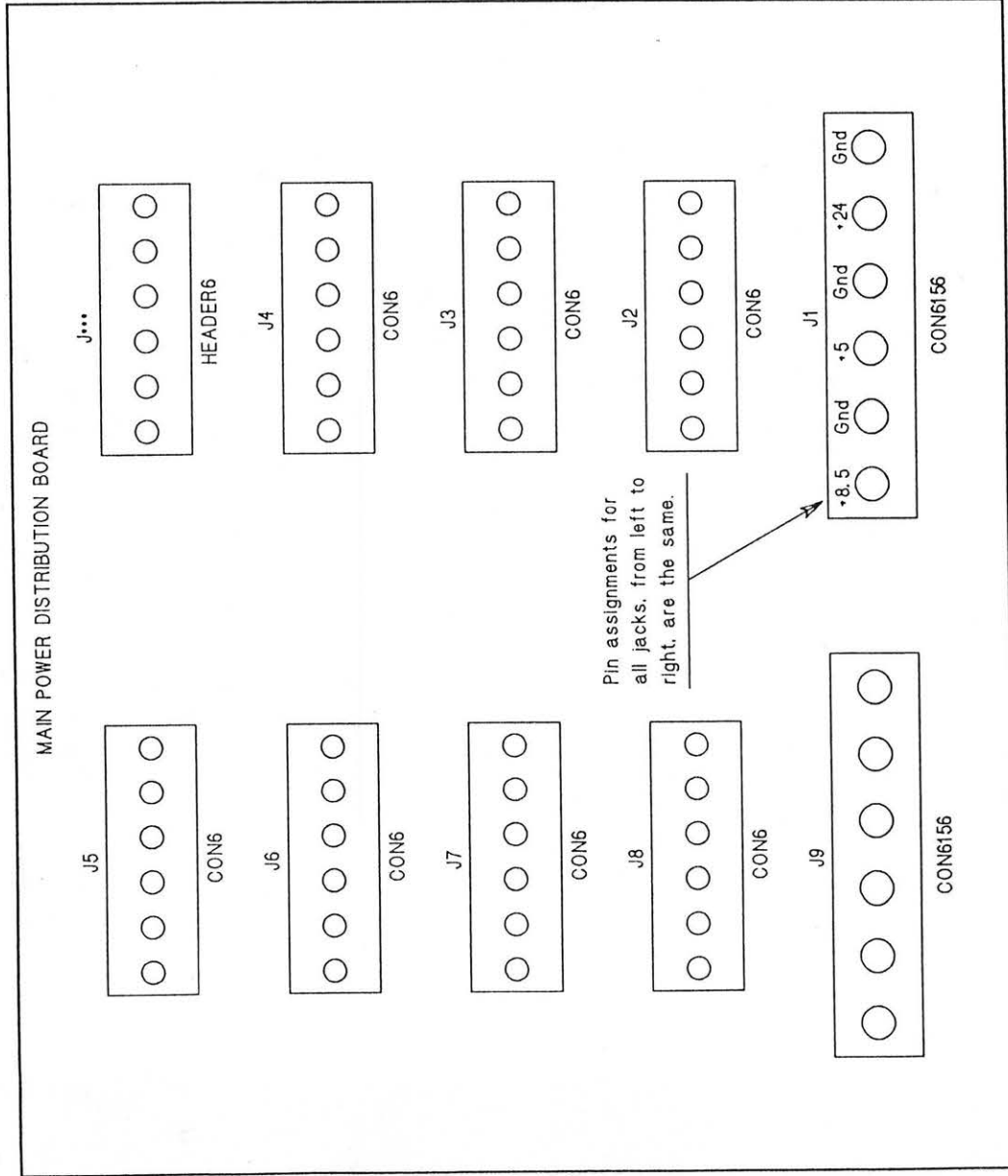

LARGE 6-PIN CABLES ON J1 AND J9

- One from main power supply
- One to Large Turntable Dist. Board

SMALL 6-PIN CABLES ON J2 THROUGH J8

- One cable each to:
- Dook bit-stripper
 - Beach Bear bit-stripper
 - Looney Bird bit-stripper
 - Lighting bit-stripper
 - Props bit-stripper

One cable to the 2-pin (24vdc) jack on the Big Important Board

•• One cable to deliver 5vdc and ground to power the VCR remote control

•• Newer shows will not have this cable. (The BIB's 6-pin jack to the remote is expanded to 8-pins to supply the needed 5vdc and ground)

Title: Main Power Distribution		Tolerance (unless indicated):	
Date: 08/18/95	Scale: Representational		

Creative Engineering, Inc.
 47 West Jefferson Street
 Orlando, Florida 32801

J1 : Receives the 24-pin cable that comes up through the main harness from the BIB.

J2 : Receives the 6-pin power cable that comes up through the main harness from the Power Distribution Board.

J6 through J9 : Female RCA jacks, connected in parallel. One serves as an input to receive the show data cable that comes up through the main harness. The other three are show data outputs to the bit-strippers of Billy Bob, Fatz, and Mitzi. The arrangement (order) of the four cables does not matter.

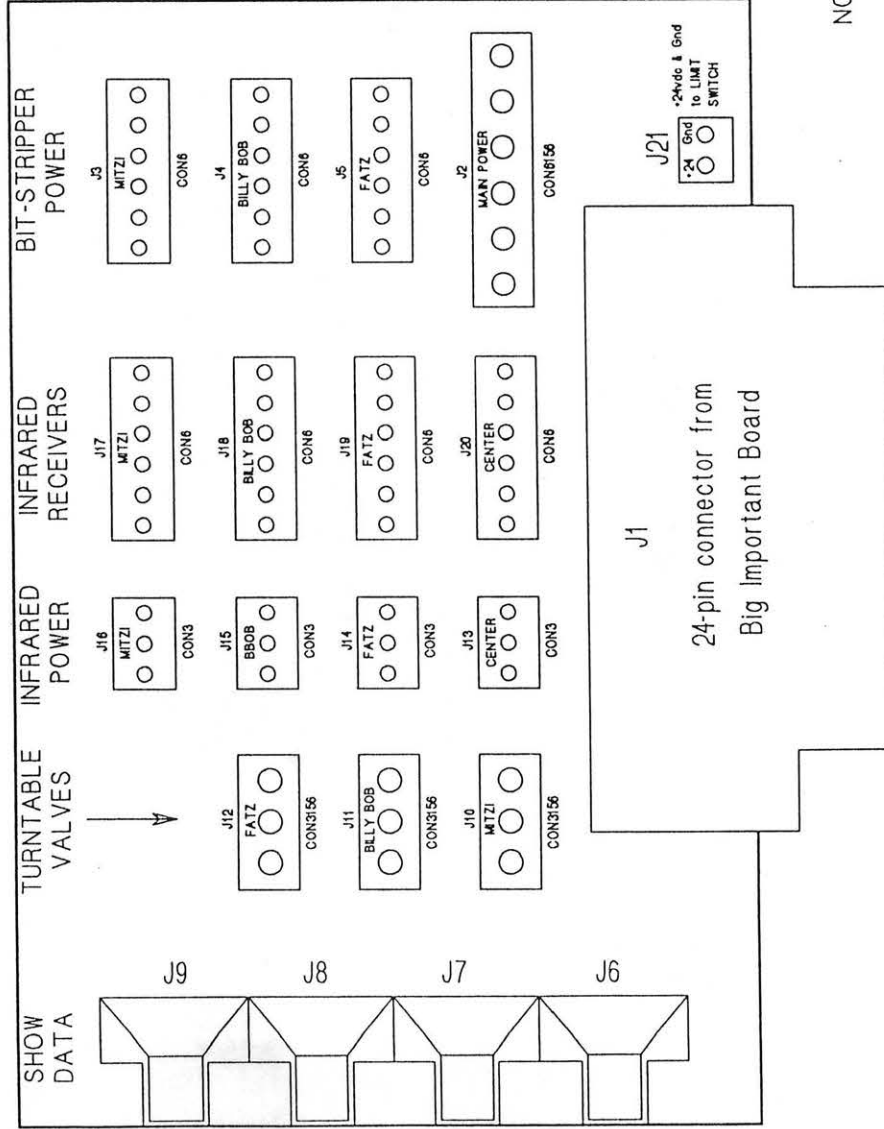

- J3 : Power distribution cable to Mitzi bit-stripper
- J4 : Power dist. cable to Billy Bob bit-stripper
- J5 : Power distribution cable to Fatz bit-stripper
- J10 : Control cable to Mitzi turntable valves
- J11 : Control cable to Billy Bob turntable valves
- J12 : Control cable to Fatz turntable valves
- J13 : Power cable to center table upper IR board
- J14 : Power cable to Fatz table upper IR board
- J15 : Power to Billy Bob table upper IR board
- J16 : Power cable to Mitzi table upper IR board
- J17 : Receiver cable to Mitzi lower IR board
- J18 : Receiver cable to BBob lower IR board
- J19 : Receiver cable to Fatz lower IR board
- J20 : Receiver cable to center table lower IR board
- J21 : Power cable to limit switch

IR = Infrared

NOTE: This board is located on a cross brace of the center turntable between Billy Bob and Fatz.

Title: Large Turntable Interface Board

Date: 08/21/95

Scale: Representational

Tolerance (unless indicated):

Creative Engineering, Inc.
47 West Jefferson Street
Orlando, Florida 32801

LARGE TURNTABLE
INTERFACE BOARD



24vdc INDICATOR LIGHT
(Mounted inside the silver dome
on the center turntable)

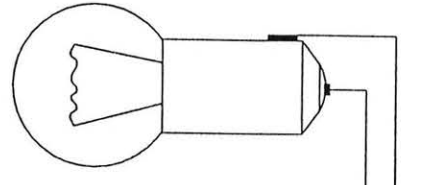

MOLEX CONNECTOR

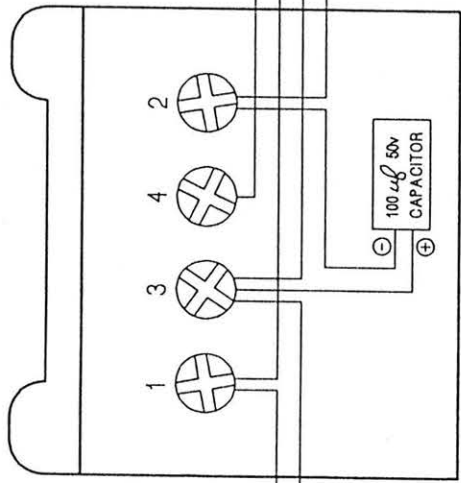
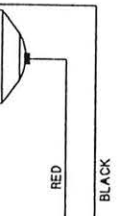

LIMIT SWITCH

(Mounted on a center turntable rail
just above the feedback gear)

MOLEX CONNECTOR

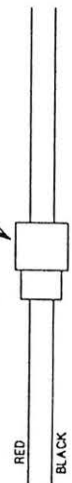

TO AIR SHUT-OFF VALVE
(Located next to large
turntable air motor valve)

Title: Limit Switch circuit

Date: 08/22/95

Scale: Representational

Tolerance (unless indicated):

Creative Engineering, Inc.
47 West Jefferson Street
Orlando, Florida 32801

OPERATING SYSTEM

The term "Operating System" stands for the collection of programs that control the show's operation during Show Play mode. These Operating System programs are on every disk provided by us.

The root of the system is the disk interface code that reads and writes to the disk. This code is written by us, and is not compatible with any other system's language or disk operating system (including the DOS typically used by an Apple computer). Therefore, the disks provided by us cannot be copied by you, as the format will not be recognized by any disk copying software.

There are two types of screen displays used by the system: graphic "panels" and text screens. During most daily operations, you will only see panels which have a light-colored background and dark-colored words and borders. A border (box) and the words inside are, together, referred to as a "button." To select or "press" a button, put the lightpen to the screen within the button area, wait for the button's border to become bolder, then press the spacebar. There are many informational buttons that will react to the lightpen, but will do nothing when the spacebar is pressed. Only the buttons that are presented for your input can actually be "pressed." Text screens (light-colored letters on black background) are used for system errors in the Operating System, and in some of the functions covered in the next main section titled SHOW ADJUSTMENT UTILITIES.

On most pages of the subsections, there will be a close facsimile of the panel, general information about the panel (if any), and a list of button choices with descriptions. You'll find that most of the panels are self-explanatory, and, with some practice, you won't need to reference this manual on a regular basis.

Before starting your system, make sure that:

- 1) the caps lock key on the computer is down (turned on).
- 2) the disk is unlocked (the slide button on the back of the disk is covering the square hole).

Starting the System

This section describes the few easy steps necessary to start the system. Also discussed are the Menu panel and setting the break time.

IMPORTANT! If you have just received a new disk and/or tape, make absolutely sure that you have removed the old disk and/or tape (and prepare it/them to be shipped back to us).

To proceed with Starting the System:

- 1) Turn on all circuit breakers for the show.
- 2) Turn on compressor system.
- 3) Turn on sound system from top down (EQ, then amps).
- 4) Turn on VCR and make sure the tape is loaded.
- 5) Insert appropriate disk in the drive.
- 6) Turn on computer monitor.
- 7) Turn on computer.
- 8) Turn to the next page.

60
03

SHOW SELECTOR START UP
Make sure that all parts of the system are turned on.
PRESS HERE TO START SHOW PLAY
PRESS HERE FOR MENU

60-03

INFO: This is the Startup panel. Follow the instructions. Make sure the VCR is turned on and the tape is loaded. Push the STOP button on the VCR (just to make sure it's stopped). Next, you must push one of the lower two buttons to either start the show or go directly to the Menu.

ACTIVE BUTTONS: 2

PRESS HERE TO START SHOWPLAY: Always press this button if you are planning to go into Show Play mode. This button will go to the panel on page 4.

PRESS HERE FOR MENU: Cancels Startup. This button will take you directly to the Menu panel shown on page 7.

IMPORTANT: If you press this button and cancel the Startup procedure, the VCR will not be rewound and cued to the first show on the tape.

60
04

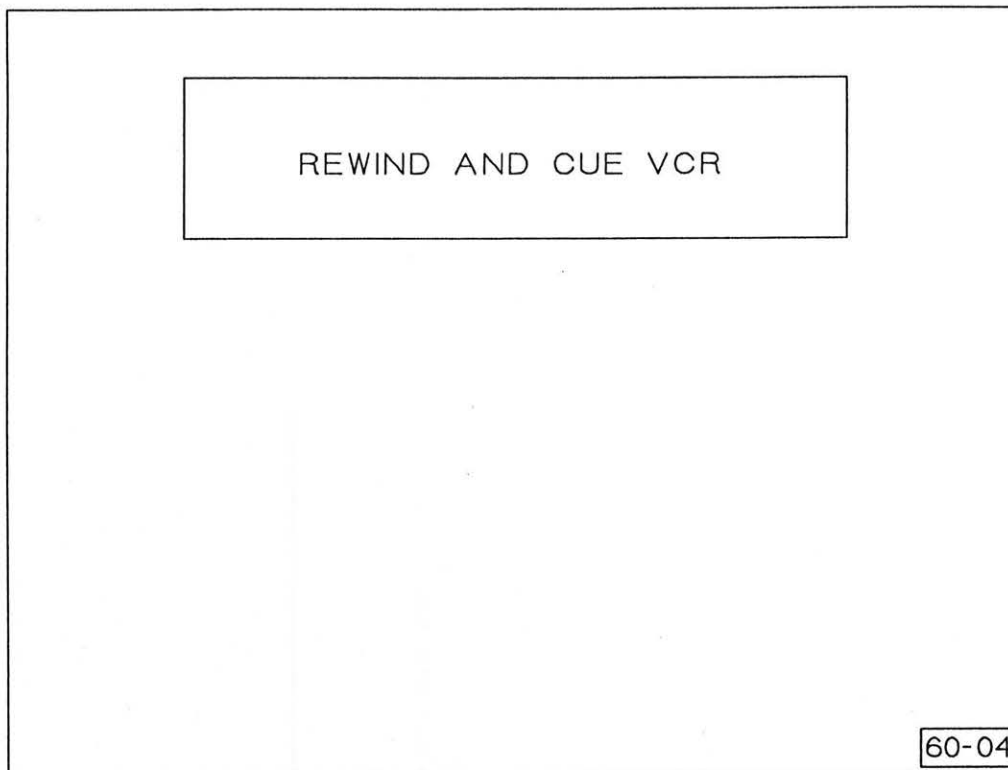

INFO: While this panel is displayed, the system (not you) will automatically:

- 1) Rewind the VCR.
- 2) Wait until approximately 2 minutes has passed from the time the VCR began rewinding. (The system does not know when the VCR is done rewinding, but it does know that, under any circumstances, it will take less than 2 minutes.)
- 3) Play the VCR up to the first stop signal.
- 4) Stop the VCR. (The deck is now cued to the first show.)

ACTIVE BUTTONS: none

[After the VCR tape is cued (stopped at the proper location), the system will automatically go to the Show Play mode panel shown on the next page.]

60
05

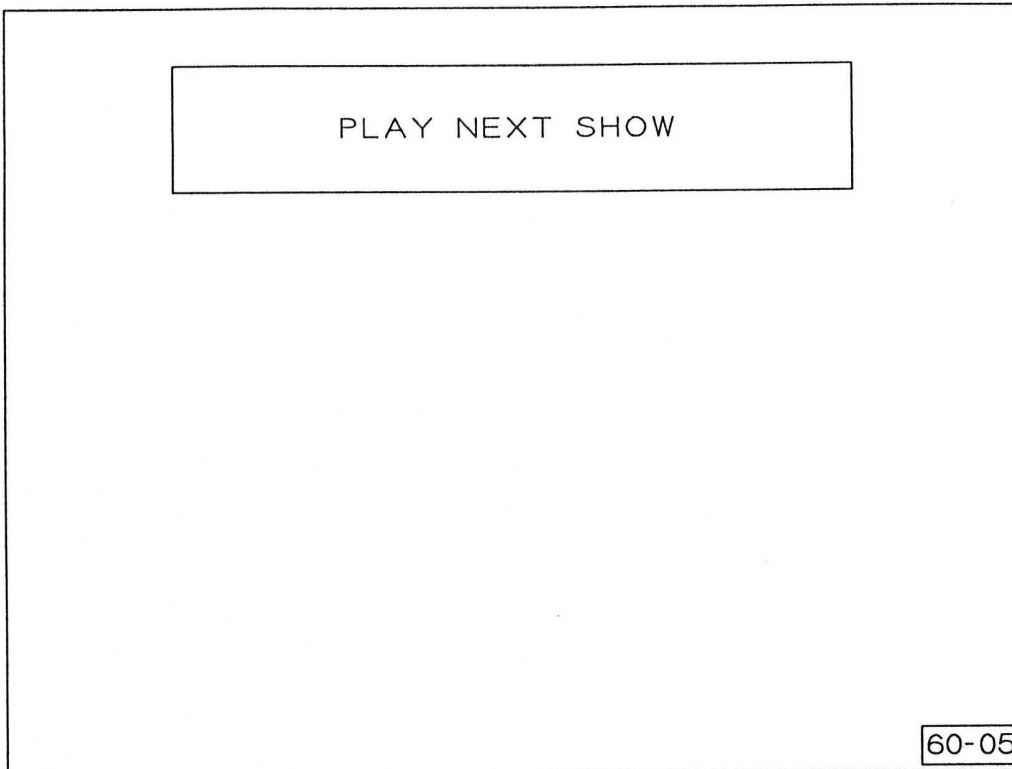

INFO: When the panel above appears, the system commands the VCR (via the remote control) to begin to play. The VCR will continue playing until the end of the show where the system reads the stop signal which stops the VCR. (The panel above remains on the screen while the show is playing.) If the system encounters a rewind signal instead of a stop signal, the system will know that it has just played the last show on the tape. The system will then automatically:

- 1) Rewind the tape back to the beginning.
- 2) Wait until approximately 2 minutes has passed from the time the VCR began rewinding. (The system does not know when the VCR is done rewinding, but it does know that, under any circumstances, it will take less than 2 minutes.)
- 3) Play the VCR up to the first stop signal.
- 4) Stop the VCR (now cued to the first show.)

ACTIVE BUTTONS: none

[When the VCR is stopped after the show is finished (or after rewinding), you will automatically be taken the panel on the next page.]

60
07

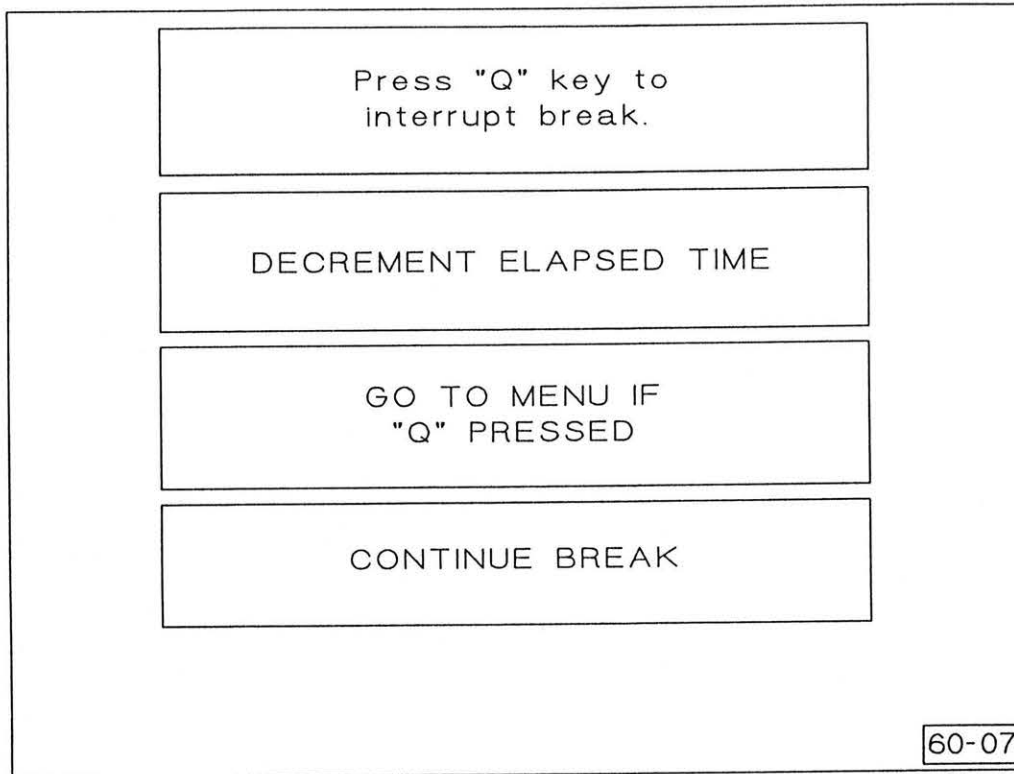

INFO: When this panel appears, it means the system is on break. The system immediately begins counting down the time left on the break. At the end of the break (if you don't interrupt it), the system will automatically return to the panel on the previous page and play the next show. If you wish to leave Show Play mode, you can interrupt the break by pressing the "Q" key at any time.

ACTIVE BUTTONS: none

[Pressing the "Q" key will take you directly to the Menu shown on page 7.]

60
02

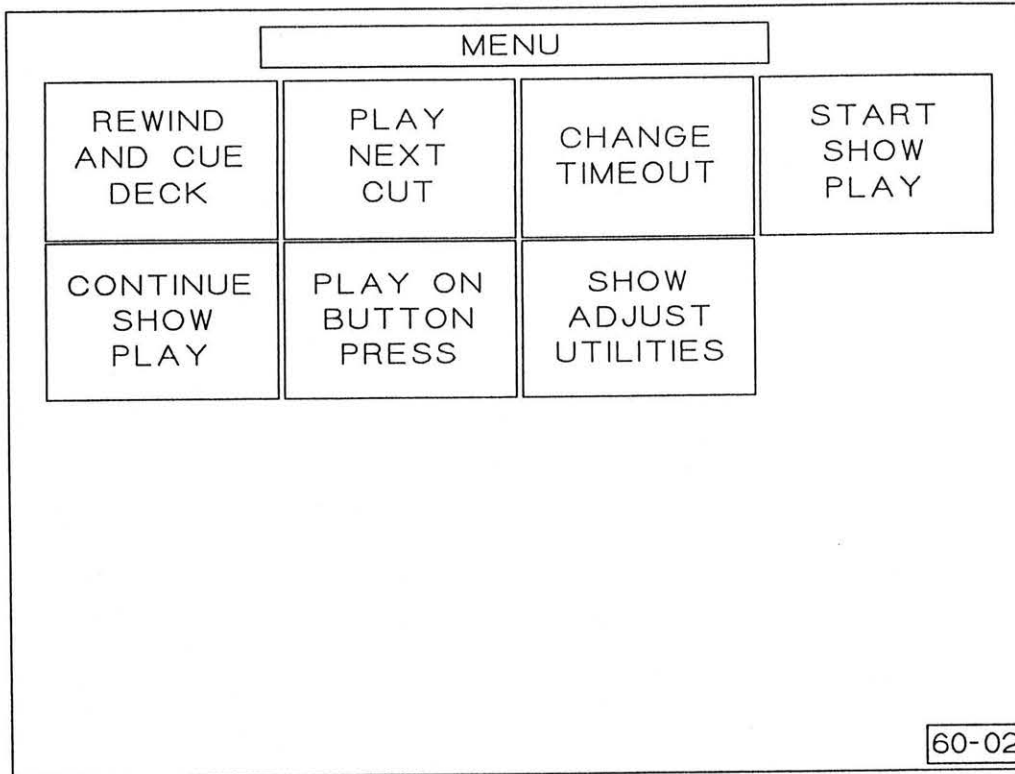

INFO: This is the Menu from which all functions of the system can be reached.

ACTIVE BUTTONS: 7

REWIND AND CUE DECK: Pressing this button will rewind and reset the tape only. The Menu panel above will remain on the screen while the system (not you) automatically:

- 1) Commands the VCR to rewind.
- 2) Waits approximately 2 minutes.
- 3) Plays the VCR up to the first stop signal.
- 4) Stops the VCR. (The deck is now cued to the first show.)

PLAY NEXT CUT: Press this button to manually play one show. The Menu panel above will remain on the screen while the system automatically commands the VCR to play (from its present position). The VCR will continue playing until the end of the show where the system reads the stop signal which stops the VCR. As usual, if the system reads a rewind signal instead of a stop signal, the system will rewind and reset the tape as described earlier.

CHANGE TIMEOUT: Allows you to change the length of the break the system takes between shows while in Show Play mode. See page 9.

START SHOW PLAY: Goes directly to the Startup sequence that rewinds and resets the tape, then automatically enters Show Play mode and plays the first show on the tape.

CONTINUE SHOW PLAY: The system will enter Show Play mode and automatically play (from the tape's present position) the next show on the tape.

PLAY ON BUTTON PRESS: Put's the system in button-press mode, where the show remains idle until you press the Manager Button. See page 11.

SHOW ADJUSTMENT UTILITIES: Leaves the Operating System entirely, and utilizes the programs described in the next main section, SHOW ADJUSTMENT UTILITIES. NOTE: When you return to the Operating System from Show Adjustment Utilities, you will not come back to the Main Menu. Instead, the system will restart the Operating System at the Startup panel shown on page 3.

60
08

HOW LONG DO YOU WANT THE BREAK?				NOW SET TO:			
				4	MINUTES		
1	2	3	4	5	8	12	15
							60-08

INFO: When the system is in Show Play mode, it takes a break between shows. The length of the break can be set to various lengths between 1 and 15 minutes. The panel shown above indicates the current length of time that the break is currently set to, and requires you to pick a new length for the break. Point the lightpen to the block with the number of minutes you desire, and press the spacebar. The length of the break is now set to the number of minutes you chose.

ACTIVE BUTTONS: none

[When you select a block and press the spacebar, the system automatically goes to the panel shown on the next page.]

60
09

SET BREAK TIME

Press this button to
save the changes to
disk for the future.

Press this button to
return to menu.

60-09

INFO: When you select a new break-length time, it is set in the computer's memory, but not saved to the disk. The new break length will remain active until the computer is turned off. If, on the other hand, you want the new break length to apply to future sessions, you must save the setting to the disk, for which a button has been provided on this panel.

ACTIVE BUTTONS: 2

Press this button...to save the change...: This button will save the new setting to the disk (the appearance of the panel on the screen will not change while the disk is accessed).

Press this button to return to menu: Returns to the Menu panel (whether or not the setting has been saved).

60
10

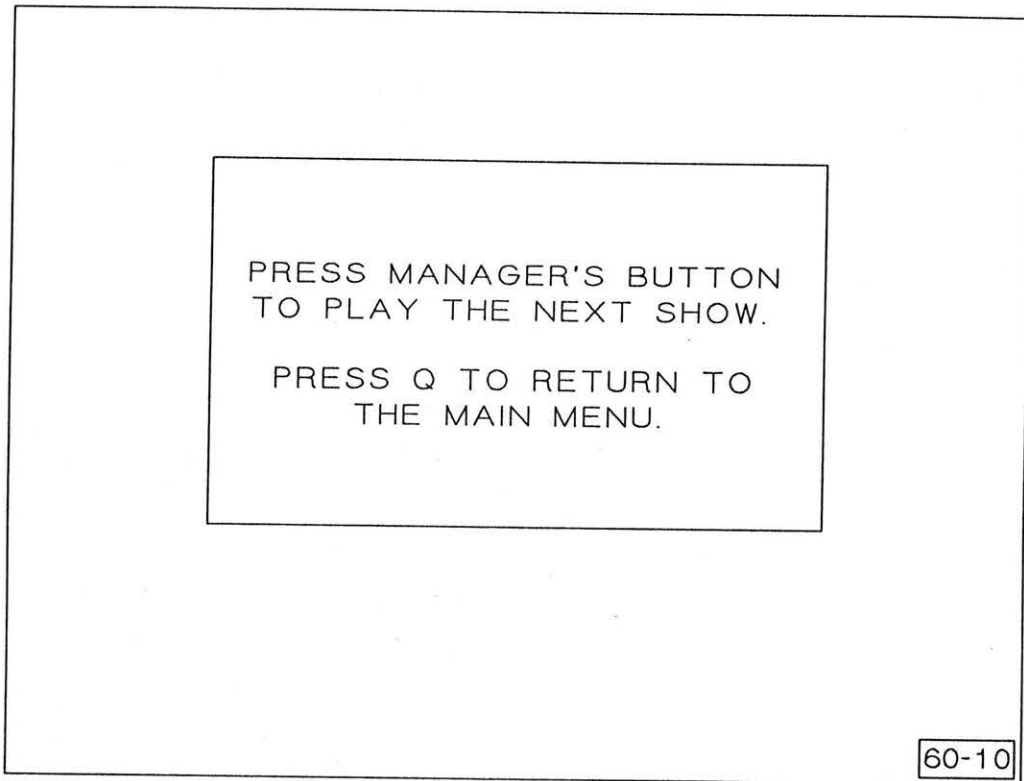

INFO: When this panel appears, the system is now in PLAY ON BUTTON PRESS mode. The system is now waiting for you to press the Manager Button to play the next show. When you press the Manager Button, the show will play. After the show, the system will wait again for you to press the Manager Button. The system will continue to operate in this manner as long as this panel is on the screen. As the panel notes, if you press the Q key (for "Quit"), the system will exit this button-press mode and return to the Menu.

ACTIVE BUTTONS: none

SHOW ADJUSTMENT UTILITIES

The SHOW ADJUSTMENT UTILITIES are diagnostic programs that are on the disk that comes with the show, but run (basically) separate from the Operating System programs. Consequently, when you exit Show Adjustment Utilities, the system will return to the Operating System's Startup panel to re-initialize everything, just as if you had just turned the computer on.

The two main purposes of the Show Adjustment Utilities are to help you properly adjust the speed of pneumatic movements, and to check the speed and positioning of the large turntable and character turntables. However, you can also manually operate any character servo, prop, or light included with your show.

IMPORTANT: See the MAINTENANCE section of the manual for guidelines on when to use certain functions of the Show Adjustment Utilities to keep your show in top-running condition!

This section is divided into the following subsections. The first five are related to the functions chosen from the main menu panel of the Show Adjustment Utilities (which is shown on the next page):

- 1) Adjust Movements
- 2) Adjust Turntables
- 3) Position Characters In Front
- 4) Read Turntable L.E.D.'s
- 5) Cycle And Time Tables

- 6) Turntable Positioning Exercise: A series of steps to help familiarize you with the character turntable positions. This subsection also describes, in detail, the infrared positioning numbers that are displayed when you choose the *Read Turntable L.E.D.'s* button on the main menu.

(go to the next page)

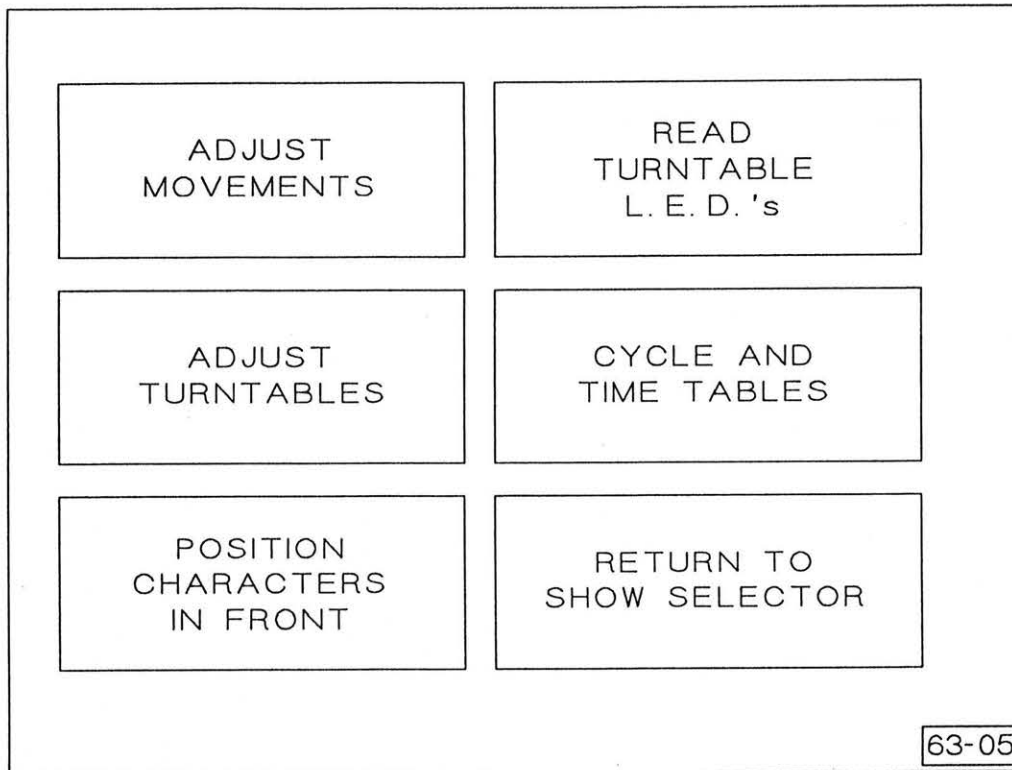

INFO: This is the main menu of the Show Adjustment Utilities.

ACTIVE BUTTONS: 6

ADJUST MOVEMENTS: Allows you to cycle or lock-on any pneumatic character movement(s), character servo(s), prop(s), or light(s). See page xx.

ADJUST TURNTABLES: Cycles any motor-driven turntable on the center stage, and indicates its speed, measured in the number of seconds it takes to travel from fully CW to fully CCW, and from fully CCW to fully CW. Also allows you to send each table to its "center" position. See page xx.

POSITION CHARACTERS IN FRONT: Automatically positions the large turntable to have any one or two center stage characters front-and-center, and have all three center stage characters facing forward at the same time. See page xx.

READ TURNTABLE L.E.D.'S: Displays the position of the large turntable and the three center stage character turntables. (The turntables' infrared positioning circuitry is described in both the CHARACTER TURNTABLES and LARGE TURNTABLE sections of the manual. The position numbers are explained at the end of this section in Turntable Positioning Exercise.) See page xx.

CYCLE AND TIME TABLES: Will automatically cycle any of the three center stage character turntables or the large turntable (one table at a time) ten times in each direction, and then display the average times of the CW and CCW rotations of the table. See page xx.

RETURN TO SHOW SELECTOR: Exits Show Adjustment Utilities altogether, and takes you back to the Startup panel of the Operating System.

Adjust Movements

This utility function is menu driven, but operates on keyboard input only, i.e., the lightpen is not used to make selections. There will be a highlight bar on each menu screen. You must use the arrow keys to move the bar up and down to highlight your choice, then press the Return key to make the selection.

In this utility, there are eight switches that start out unassigned. You can assign any one movement or any one light to any switch, and any combination of assigned or unassigned switches is acceptable. You can then command the system to cycle the switches on and off automatically, or simply turn the switches on and leave them on (until you turn them off).

Another option is to have the system AUTO ASSIGN switches for you. In this case, you choose a movement on Mitzi to assign to the first switch, and the system automatically assigns the same movement on the other characters (that have that movement) to successive switches. This is very useful in synchronizing character movements. (The reason Mitzi is the default character in AUTO ASSIGN is because while some characters may have less movements than Mitzi, no other character has a movement that Mitzi does not have.)

IMPORTANT: Since there are an infinite number of arrangements of characters, props, and lights that can be designed into a show, the menus in this subsection have been taken from a system that operates a full, three-stage show with every possible prop and light. Therefore, your actual menus may have less listings or options than the examples on the pages herein. Characters, props, and other controls that do not apply to your show's configuration will not be on your menus.

The first menu of Show Adjustment Utilities is shown on the next page.

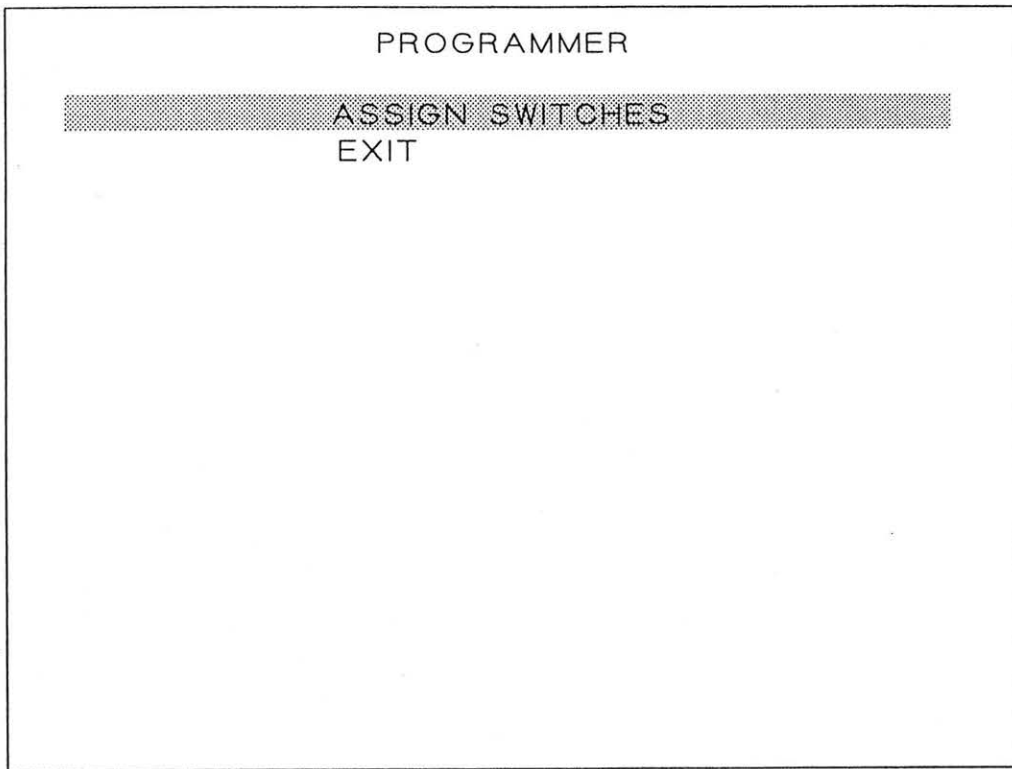

CHOICES: 2

ASSIGN SWITCHES: Goes to the main Switch Assignment screen shown on the next page.

EXIT: Returns to the main menu panel of the Show Adjustment Utilities.

SWITCH ASSIGNMENT

```
-----  
SW01 NOT ASSIGNED  
SW02 NOT ASSIGNED  
SW03 NOT ASSIGNED  
SW04 NOT ASSIGNED  
SW05 NOT ASSIGNED  
SW06 NOT ASSIGNED  
SW07 NOT ASSIGNED  
SW08 NOT ASSIGNED
```

CLEAR ALL SWITCHES
MOVEMENTS ON
1.0 SECOND TIMER
AUTO ASSIGN FOR ADJUST
EXIT

This is the main Switch Assignment screen. Here, you can pick a switch(s) to assign, clear all switches of any assignments, or activate switches that have already been assigned. Use the arrow keys to move the bar, and press Return to make the selection. Below are brief descriptions of the functions available on this screen. Following this page, and through the rest of this subsection, are four examples where you will be stepped through actual assignments to help familiarize you with assignment methods.

CHOICES: 13

SW01 through *SW08*: To assign one movement or light at a time, place the bar over the first available (not assigned) switch number, and press Return to see a list of things that can be assigned. See examples #1 and #2. Example #1 begins on page 5.

CLEAR ALL SWITCHES: Place the bar here and press Return to clear all previously assigned switches. The switches will then all say "not assigned."

MOVEMENTS ON: If you put the bar here and press Return, the system turns on all assigned movements (or lights) on the list, and leaves them on. Press the spacebar (or any other key) on the keyboard to turn them back off. See example #4 that begins on page 24.

1.0 SECOND TIMER: Put the bar here and press Return, and the system will automatically switch the assigned movements (or lights) on and off, repeatedly, using a predefined internal timer. Press the spacebar (or any other key) on the keyboard to stop the timer. NOTE: The timer is not actually one second in each direction (on or off). It's actually somewhere in between one and two seconds for most shows. The term "1.0 second timer" is merely a long-used name associated with this function. See examples #1 and #2. Example #1 begins on page 5.

AUTO ASSIGN FOR ADJUST: Place the bar here and press Return, and you will be shown a list of all possible Mitzi pneumatic movements that can be assigned to switch #1. The system will then automatically assign successive switches to that same movement in all other characters that have it. See example #3 that begins on page 21.

EXIT: Returns to the first menu shown back on page 2.

The first example begins on the next page.

SWITCH ASSIGNMENT

```
-----  
SW01      NOT ASSIGNED  
SW02      NOT ASSIGNED  
SW03      NOT ASSIGNED  
SW04      NOT ASSIGNED  
SW05      NOT ASSIGNED  
SW06      NOT ASSIGNED  
SW07      NOT ASSIGNED  
SW08      NOT ASSIGNED
```

CLEAR ALL SWITCHES
MOVEMENTS ON
1.0 SECOND TIMER
AUTO ASSIGN FOR ADJUST
EXIT

EXAMPLE #1:

Let's suppose you want to cycle Mitzi's right elbow to adjust its movement speed. First, look at the switch list to ensure that all switches say NOT ASSIGNED. If any are assigned, then use the arrow keys to move the highlight bar down to CLEAR ALL SWITCHES, and press the Return key. Now all switches are cleared and should say NOT ASSIGNED. Next, you will want to assign Mitzi's right elbow to switch #1, so position the bar on SW01, and press Return. This will take you to the menu on the next page.

(go to the next page)

SWITCH ASSIGNMENT

SWITCH = 01

MITZI PNEUMATICS

MITZI SERVOS

BILLYBOB PNEUMATICS

BILLYBOB SERVOS

FATZ PNEUMATICS

FATZ SERVOS

DOOK PNEUMATICS

DOOK SERVOS

BEACH BEAR PNEUMATICS

BEACH BEAR SERVOS

LOONEY BIRD-LAB PNEUMATICS

LOONEY BIRD-LAB SERVOS

LOONEY BIRD-WIN PNEUMATICS

LOONEY BIRD-WIN SERVOS

PROPS

CONTROLS

STAGE LIGHTS

COLOR AND STROBE LIGHTS

CLEAR THIS SWITCH

ASSIGN BIT NUMBER

EXIT

(example #1 cont.)

This list breaks up all of the movements and lights in to groups that make it easier to isolate the one you're after. Notice that the switch number that is ready to be assigned is displayed near the top-left of the screen - switch #1. Mitzi's right elbow is a pneumatic movement, so place the bar over MITZI PNEUMATICS, and press Return. This will take you to the menu on the next page.

NOTE: There is a complete list of movements and lights in each group on page 29.

(go to the next page)

```

                                SWITCH ASSIGNMENT
-----
SWITCH = 01                                MITZI
      MOUTH
      LIP
      HEAD TURN
      HEAD DOWN
      HEAD TILT RIGHT
      HEAD TILT LEFT
      BODY TURN RIGHT
      BODY TILT RIGHT
      BODY TILT LEFT
      KNEE BEND
      WRIST RIGHT
      WRIST LEFT
      ELBOW RIGHT
      ELBOW LEFT
      ARM TWIST RIGHT
      ARM TWIST LEFT
      ARM RAISE RIGHT
      ARM RAISE LEFT
      SHOULDER RIGHT
      SHOULDER LEFT
      EXIT

```

(example #1 cont.)

You are now presented a list of all pneumatic movements on Mitzi (except the ears). Since this is a list of individual movements (not groups), making a selection on this screen will actually assign the switch number displayed near the top-left of the screen - switch #1. Move the bar down to ELBOW RIGHT, and press Return. The moment you press Return, switch #1 is assigned Mitzi's right elbow, the bar moves down one row, and the indicator near the top-left of the screen changes to SWITCH = 02, indicating the system is now ready to assign a movement to switch #2, if you choose. This is shown on the next page.

(go to the next page)

```

                                SWITCH ASSIGNMENT
-----
SWITCH = 02                                MITZI
      MOUTH
      LIP
      HEAD TURN
      HEAD DOWN
      HEAD TILT RIGHT
      HEAD TILT LEFT
      BODY TURN RIGHT
      BODY TILT RIGHT
      BODY TILT LEFT
      KNEE BEND
      WRIST RIGHT
      WRIST LEFT
      ELBOW RIGHT
      ELBOW LEFT
      ARM TWIST RIGHT
      ARM TWIST LEFT
      ARM RAISE RIGHT
      ARM RAISE LEFT
      SHOULDER RIGHT
      SHOULDER LEFT
      EXIT

```

(example #1 cont.)

Your screen should now look similar to this. The system is ready to assign switch #2, but we're only interested in the one movement that has already been assigned. Move the bar down to EXIT as shown above, and press Return. This will take you back to the main Switch Assignment screen, as shown on the next page.

(go to the next page)

```

                                SWITCH ASSIGNMENT
=====
SW01                          MITZI ELBOW RIGHT
SW02                          NOT ASSIGNED
SW03                          NOT ASSIGNED
SW04                          NOT ASSIGNED
SW05                          NOT ASSIGNED
SW06                          NOT ASSIGNED
SW07                          NOT ASSIGNED
SW08                          NOT ASSIGNED

                                CLEAR ALL SWITCHES
                                MOVEMENTS ON
                                1.0 SECOND TIMER
                                AUTO ASSIGN FOR ADJUST
                                EXIT

```

(example #1 cont.)

Back at the main screen, the switch assignment you just made is now on the list. Since the idea is to steadily cycle Mitzi's right elbow, move the bar down to 1.0 SECOND TIMER, and press Return. The screen does not change in appearance, but Mitzi's elbow movement begins - on, off, on, off, etc. When you want the movement to stop, press the spacebar (or any other key).

END OF EXAMPLE #1.

SWITCH ASSIGNMENT

```
-----  
SW01      NOT ASSIGNED  
SW02      NOT ASSIGNED  
SW03      NOT ASSIGNED  
SW04      NOT ASSIGNED  
SW05      NOT ASSIGNED  
SW06      NOT ASSIGNED  
SW07      NOT ASSIGNED  
SW08      NOT ASSIGNED
```

```
      CLEAR ALL SWITCHES  
      MOVEMENTS ON  
      1.0 SECOND TIMER  
      AUTO ASSIGN FOR ADJUST  
      EXIT
```

EXAMPLE #2:

Let's suppose you want both Bill Bob and Fatz to raise both arms up and down using the timer. First, look at the switch list to ensure that all switches say NOT ASSIGNED. If any are assigned, then use the arrow keys to move the highlight bar down to CLEAR ALL SWITCHES, and press the Return key. Now all switches are cleared and should say NOT ASSIGNED. Next, you will want to assign the first of the four switches necessary to cycle four different movements at one time, so position the bar on SW01, and press Return. This will take you to the menu on the next page.

(go to the next page)

SWITCH ASSIGNMENT

SWITCH = 01

MITZI PNEUMATICS
MITZI SERVOS
BILLYBOB PNEUMATICS
BILLYBOB SERVOS
FATZ PNEUMATICS
FATZ SERVOS
DOOK PNEUMATICS
DOOK SERVOS
BEACH BEAR PNEUMATICS
BEACH BEAR SERVOS
LOONEY BIRD-LAB PNEUMATICS
LOONEY BIRD-LAB SERVOS
LOONEY BIRD-WIN PNEUMATICS
LOONEY BIRD-WIN SERVOS
PROPS
CONTROLS
STAGE LIGHTS
COLOR AND STROBE LIGHTS
CLEAR THIS SWITCH
ASSIGN BIT NUMBER
EXIT

(example #2 cont.)

This list breaks up all of the movements and lights in to groups that make it easier to isolate the one you're after. Notice that the switch number that is ready to be assigned is displayed near the top-left of the screen - switch #1. The four switches you need to assign can be assigned in any order, but let's start with Billy Bob's arms. Place the bar over BILLYBOB PNEUMATICS, and press Return. This will take you to the menu on the next page.

NOTE: There is a complete list of movements and lights in each group on page 29.

(go to the next page)

```
                SWITCH ASSIGNMENT
-----
SWITCH = 01                                BILLYBOB
      MOUTH
      LIP
      HEAD TURN
      HEAD DOWN
      HEAD TILT RIGHT
      HEAD TILT LEFT
      BODY TURN RIGHT
      BODY TILT RIGHT
      BODY TILT LEFT
      KNEE BEND
      WRIST RIGHT
      WRIST LEFT
      ELBOW RIGHT
      ELBOW LEFT
      ARM TWIST RIGHT
      ARM TWIST LEFT
      ARM RAISE RIGHT
      ARM RAISE LEFT
      SHOULDER RIGHT
      SHOULDER LEFT
      EXIT
```

(example #2 cont.)

You are now presented a list of all pneumatic movements on Billy Bob. Move the bar down to ARM RAISE RIGHT, and press Return. The moment you press Return, switch #1 is assigned Billy Bob's right arm raise movement, the bar moves down one row, and the indicator near the top-left of the screen changes to SWITCH = 02, indicating the system is now ready to assign a movement to switch #2, if you choose. This is shown on the next page.

(go to the next page)

```

                                SWITCH ASSIGNMENT
-----
SWITCH = 02                                BILLYBOB
      MOUTH
      LIP
      HEAD TURN
      HEAD DOWN
      HEAD TILT RIGHT
      HEAD TILT LEFT
      BODY TURN RIGHT
      BODY TILT RIGHT
      BODY TILT LEFT
      KNEE BEND
      WRIST RIGHT
      WRIST LEFT
      ELBOW RIGHT
      ELBOW LEFT
      ARM TWIST RIGHT
      ARM TWIST LEFT
      ARM RAISE RIGHT
      ARM RAISE LEFT
      SHOULDER RIGHT
      SHOULDER LEFT
      EXIT

```

(example #2 cont.)

Your screen should now look similar to this. The system is ready to assign switch #2. The next movement we want to assign (to switch #2) is on this same list, so move the bar down to ARM RAISE LEFT, and press Return. The moment you press Return, switch #2 is assigned Billy Bob's left arm raise movement, the bar moves down one row, and the indicator near the top-left of the screen changes to SWITCH = 03, indicating the system is now ready to assign a movement to switch #3, if you choose. This is shown on the next page.

(go to the next page)

```

                                SWITCH ASSIGNMENT
-----
SWITCH = 03                                BILLYBOB
      MOUTH
      LIP
      HEAD TURN
      HEAD DOWN
      HEAD TILT RIGHT
      HEAD TILT LEFT
      BODY TURN RIGHT
      BODY TILT RIGHT
      BODY TILT LEFT
      KNEE BEND
      WRIST RIGHT
      WRIST LEFT
      ELBOW RIGHT
      ELBOW LEFT
      ARM TWIST RIGHT
      ARM TWIST LEFT
      ARM RAISE RIGHT
      ARM RAISE LEFT
      SHOULDER RIGHT
      SHOULDER LEFT
      EXIT

```

(example #2 cont.)

Your screen should now look similar to this. The system is ready to assign switch #3, but the next two movements we want to assign do not belong to Billy Bob. Move the bar down to EXIT as shown above, and press Return. This will take you back to the main Switch Assignment screen, as shown on the next page.

(go to the next page)

```

                                SWITCH ASSIGNMENT
=====
SW01      BILLYBOB ARM RAISE RIGHT
SW02      BILLYBOB ARM RAISE LEFT
SW03      NOT ASSIGNED
SW04      NOT ASSIGNED
SW05      NOT ASSIGNED
SW06      NOT ASSIGNED
SW07      NOT ASSIGNED
SW08      NOT ASSIGNED

      CLEAR ALL SWITCHES
      MOVEMENTS ON
      1.0 SECOND TIMER
      AUTO ASSIGN FOR ADJUST
      EXIT

```

(example #2 cont.)

Back at the main screen, your screen should look similar to this. The first two switch assignments you just made are now on the list. Now we're ready to assign Fatz's arm raises to switches #3 and #4. Make sure the bar is on SW03, and press Return. This will take you to the menu on the next page.

(go to the next page)

```

                                SWITCH ASSIGNMENT
-----
SWITCH = 03
    MITZI PNEUMATICS
    MITZI SERVOS
    BILLYBOB PNEUMATICS
    BILLYBOB SERVOS
    FATZ PNEUMATICS
    FATZ SERVOS
    DOOK PNEUMATICS
    DOOK SERVOS
    BEACH BEAR PNEUMATICS
    BEACH BEAR SERVOS
    LOONEY BIRD-LAB PNEUMATICS
    LOONEY BIRD-LAB SERVOS
    LOONEY BIRD-WIN PNEUMATICS
    LOONEY BIRD-WIN SERVOS
    PROPS
    CONTROLS
    STAGE LIGHTS
    COLOR AND STROBE LIGHTS
    CLEAR THIS SWITCH
    ASSIGN BIT NUMBER
    EXIT

```

(example #2 cont.)

The switch number that is ready to be assigned is displayed near the top-left of the screen - switch #3. Place the bar over FATZ PNEUMATICS, and press Return. This will take you to the menu on the next page.

NOTE: There is a complete list of movements and lights in each group on page 29.

(go to the next page)

```

                                SWITCH ASSIGNMENT
-----
SWITCH = 03                                FATZ
      MOUTH
      LIP
      HEAD TURN
      HEAD DOWN
      HEAD TILT RIGHT
      HEAD TILT LEFT
      BODY TURN RIGHT
      BODY TILT RIGHT
      BODY TILT LEFT
      KNEE BEND
      WRIST RIGHT
      WRIST LEFT
      ELBOW RIGHT
      ELBOW LEFT
      ARM TWIST RIGHT
      ARM TWIST LEFT
      ARM RAISE RIGHT
      ARM RAISE LEFT
      SHOULDER RIGHT
      SHOULDER LEFT
      EXIT

```

(example #2 cont.)

You are now presented a list of all pneumatic movements on Fatz. Move the bar down to ARM RAISE RIGHT, and press Return. The moment you press Return, switch #3 is assigned Fatz's right arm raise movement, the bar moves down one row, and the indicator near the top-left of the screen changes to SWITCH = 04, indicating the system is now ready to assign a movement to switch #4, if you choose. This is shown on the next page.

(go to the next page)

```

                                SWITCH ASSIGNMENT
-----
SWITCH = 04                                FATZ
      MOUTH
      LIP
      HEAD TURN
      HEAD DOWN
      HEAD TILT RIGHT
      HEAD TILT LEFT
      BODY TURN RIGHT
      BODY TILT RIGHT
      BODY TILT LEFT
      KNEE BEND
      WRIST RIGHT
      WRIST LEFT
      ELBOW RIGHT
      ELBOW LEFT
      ARM TWIST RIGHT
      ARM TWIST LEFT
      ARM RAISE RIGHT
      ARM RAISE LEFT
      SHOULDER RIGHT
      SHOULDER LEFT
      EXIT

```

(example #2 cont.)

Your screen should now look similar to this. The system is ready to assign switch #4. The next movement we want to assign (to switch #4) is on this same list, so move the bar down to ARM RAISE LEFT, and press Return. The moment you press Return, switch #4 is assigned Fatz's left arm raise movement, the bar moves down one row, and the indicator near the top-left of the screen changes to SWITCH = 05, indicating the system is now ready to assign a movement to switch #5, if you choose. This is shown on the next page.

(go to the next page)

```

                                SWITCH ASSIGNMENT
-----
SWITCH = 05                                FATZ
      MOUTH
      LIP
      HEAD TURN
      HEAD DOWN
      HEAD TILT RIGHT
      HEAD TILT LEFT
      BODY TURN RIGHT
      BODY TILT RIGHT
      BODY TILT LEFT
      KNEE BEND
      WRIST RIGHT
      WRIST LEFT
      ELBOW RIGHT
      ELBOW LEFT
      ARM TWIST RIGHT
      ARM TWIST LEFT
      ARM RAISE RIGHT
      ARM RAISE LEFT
      SHOULDER RIGHT
      SHOULDER LEFT
      EXIT

```

(example #2 cont.)

Your screen should now look similar to this. The system is ready to assign switch #5, but we don't want to assign any more movements. Move the bar down to EXIT as shown above, and press Return. This will take you back to the main Switch Assignment screen, as shown on the next page.

(go to the next page)

```

                                SWITCH ASSIGNMENT
=====
SW01      BILLYBOB ARM RAISE RIGHT
SW02      BILLYBOB ARM RAISE LEFT
SW03      FATZ ARM RAISE RIGHT
SW04      FATZ ARM RAISE LEFT
SW05      NOT ASSIGNED
SW06      NOT ASSIGNED
SW07      NOT ASSIGNED
SW08      NOT ASSIGNED

                                CLEAR ALL SWITCHES
                                MOVEMENTS ON
                                1.0 SECOND TIMER
                                AUTO ASSIGN FOR ADJUST
                                EXIT

```

(example #2 cont.)

Back at the main screen, your screen should look similar to this. The four switch assignments you made are now on the list. Since the idea is to steadily cycle all four arm-raises, move the bar down to 1.0 SECOND TIMER, and press Return. The screen does not change in appearance, but Billy Bob's and Fatz's arm-raise movements begin - on, off, on, off, etc. When you want the movements to stop, press the spacebar (or any other key).

END OF EXAMPLE #2.

SWITCH ASSIGNMENT

```
-----  
SW01          NOT ASSIGNED  
SW02          NOT ASSIGNED  
SW03          NOT ASSIGNED  
SW04          NOT ASSIGNED  
SW05          NOT ASSIGNED  
SW06          NOT ASSIGNED  
SW07          NOT ASSIGNED  
SW08          NOT ASSIGNED
```

```
CLEAR ALL SWITCHES  
MOVEMENTS ON  
1.0 SECOND TIMER
```

```
AUTO ASSIGN FOR ADJUST  
EXIT
```

EXAMPLE #3:

Let's suppose you want to cycle the body turn movements of all the characters, simultaneously, to make sure they are all set at the proper speed, and synchronized to each other. First, look at the switch list to ensure that all switches say NOT ASSIGNED. If any are assigned, then use the arrow keys to move the highlight bar down to CLEAR ALL SWITCHES, and press the Return key. Now all switches are cleared and should say NOT ASSIGNED. Next, you will want to see a list of character movements that can be automatically assigned, so position the bar on AUTO ASSIGN FOR ADJUST, and press Return. This will take you to the menu on the next page.

(go to the next page)

```

                                SWITCH ASSIGNMENT
-----
SWITCH = 01                                MITZI
      MOUTH
      LIP
      HEAD TURN
      HEAD DOWN
      HEAD TILT RIGHT
      HEAD TILT LEFT
      BODY TURN RIGHT
      BODY TILT RIGHT
      BODY TILT LEFT
      KNEE BEND
      WRIST RIGHT
      WRIST LEFT
      ELBOW RIGHT
      ELBOW LEFT
      ARM TWIST RIGHT
      ARM TWIST LEFT
      ARM RAISE RIGHT
      ARM RAISE LEFT
      SHOULDER RIGHT
      SHOULDER LEFT
      EXIT

```

(example #3 cont.)

You are now presented a list of all pneumatic movements on Mitzi (except the ears). Remember, Mitzi is the default character used to pick auto-assign movements. Move the bar down to BODY TURN RIGHT, and press Return. The moment you press Return, the switches (however many are needed) are automatically assigned to the body turn-right movements of all characters that have that particular movement. The system then automatically returns to the main screen as shown on the next page.

(go to the next page)

```
SWITCH ASSIGNMENT
-----
SW01          MITZI BODY TURN RIGHT
SW02          BILLYBOB BODY TURN RIGHT
SW03          FATZ BODY TURN RIGHT
SW04          DOOK BODY TURN RIGHT
SW05          BEACH BEAR BODY TURN RIGHT
SW06 LOONEY BIRD-LAB BODY TURN RIGHT
SW07          NOT ASSIGNED
SW08          NOT ASSIGNED

          CLEAR ALL SWITCHES
          MOVEMENTS ON
          1.0 SECOND TIMER
          AUTO ASSIGN FOR ADJUST
          EXIT
```

(example #3 cont.)

Back at the main screen, your screen should look similar to this. The switch assignments that the system made for you are now on the list. Since the idea is to steadily cycle all body turn movements simultaneously, move the bar down to 1.0 SECOND TIMER, and press Return. The screen does not change in appearance, but all characters with body turn-right movements begin to move - on, off, on, off, etc. When you want the movements to stop, press the spacebar (or any other key).

END OF EXAMPLE #3.

SWITCH ASSIGNMENT

```
-----  
SW01      NOT ASSIGNED  
SW02      NOT ASSIGNED  
SW03      NOT ASSIGNED  
SW04      NOT ASSIGNED  
SW05      NOT ASSIGNED  
SW06      NOT ASSIGNED  
SW07      NOT ASSIGNED  
SW08      NOT ASSIGNED
```

```
      CLEAR ALL SWITCHES  
      MOVEMENTS ON  
      1.0 SECOND TIMER  
      AUTO ASSIGN FOR ADJUST  
      EXIT
```

EXAMPLE #4:

Let's suppose you want to turn on the blue neon note and have it stay on to check its operation. According to the PROPS / LIGHTS section of the manual, the blue neon light is Note #2. First, look at the switch list to ensure that all switches say NOT ASSIGNED. If any are assigned, then use the arrow keys to move the highlight bar down to CLEAR ALL SWITCHES, and press the Return key. Now all switches are cleared and should say NOT ASSIGNED. Next, you will want to assign Note #2 to switch #1, so position the bar on SW01, and press Return. This will take you to the menu on the next page.

(go to the next page)

```
                SWITCH ASSIGNMENT
-----
SWITCH = 01
    MITZI PNEUMATICS
    MITZI SERVOS
    BILLYBOB PNEUMATICS
    BILLYBOB SERVOS
    FATZ PNEUMATICS
    FATZ SERVOS
    DOOK PNEUMATICS
    DOOK SERVOS
    BEACH BEAR PNEUMATICS
    BEACH BEAR SERVOS
    LOONEY BIRD-LAB PNEUMATICS
    LOONEY BIRD-LAB SERVOS
    LOONEY BIRD-WIN PNEUMATICS
    LOONEY BIRD-WIN SERVOS
    PROPS
    CONTROLS
    STAGE LIGHTS
    COLOR AND STROBE LIGHTS
    CLEAR THIS SWITCH
    ASSIGN BIT NUMBER
    EXIT
```

(example #4 cont.)

This list breaks up all of the movements and lights in to groups that make it easier to isolate the one you're after. Notice that the switch number that is ready to be assigned is displayed near the top-left of the screen - switch #1. Note #2 is in the STAGE LIGHTS group, so place the bar over STAGE LIGHTS, and press Return. This will take you to the menu on the next page.

NOTE: There is a complete list of movements and lights in each group on page 29.

(go to the next page)

```

                                SWITCH ASSIGNMENT
=====
SWITCH = 01                      STAGE LIGHTS
    STAGE RIGHT SPOT
    CNTR STAGE RIGHT
    CNTR STAGE CNTR
    CNTR STAGE LEFT
    STAGE LEFT SPOT
    ROCKAFIRE NEON
    EXPLOSION NEON
    RIGHT FLOOR SPOT
    LEFT FLOOR SPOT
    NOTE #1
    NOTE #2
    NOTE #3
    NOTE #4
    EXIT

```

(example #4 cont.)

You are now presented a list of all lights in the STAGE LIGHTS group. Since this is a list of individual lights (not groups), making a selection on this screen will actually assign the switch number displayed near the top-left of the screen - switch #1. Move the bar down to NOTE #2, and press Return. The moment you press Return, switch #1 is assigned neon Note #2, the bar moves down one row, and the indicator near the top-left of the screen changes to SWITCH = 02, indicating the system is now ready to assign a movement to switch #2, if you choose. This is shown on the next page.

(go to the next page)

```

                                SWITCH ASSIGNMENT
-----
SWITCH = 02                      STAGE LIGHTS
    STAGE RIGHT SPOT
    CNTR STAGE RIGHT
    CNTR STAGE CNTR
    CNTR STAGE LEFT
    STAGE LEFT SPOT
    ROCKAFIRE NEON
    EXPLOSION NEON
    RIGHT FLOOR SPOT
    LEFT FLOOR SPOT
    NOTE #1
    NOTE #2
    NOTE #3
    NOTE #4
    EXIT

```

(example #4 cont.)

Your screen should now look similar to this. The system is ready to assign switch #2, but, this time, we're only interested in the one light that has already been assigned. Move the bar down to EXIT as shown above, and press Return. This will take you back to the main Switch Assignment screen, as shown on the next page.

(go to the next page)

```
SWITCH ASSIGNMENT
-----
SW01          STAGE LIGHTS NOTE #2
SW02          NOT ASSIGNED
SW03          NOT ASSIGNED
SW04          NOT ASSIGNED
SW05          NOT ASSIGNED
SW06          NOT ASSIGNED
SW07          NOT ASSIGNED
SW08          NOT ASSIGNED

CLEAR ALL SWITCHES
MOVEMENTS ON
1.0 SECOND TIMER
AUTO ASSIGN FOR ADJUST
EXIT
```

(example #4 cont.)

Back at the main screen, the switch assignment you just made is now on the list. Since the idea this time is to turn the light on and have it stay on, move the bar down to MOVEMENTS ON, and press Return. The screen does not change in appearance, but the blue neon Note #2 is now on. When you want the light to turn back off, press the spacebar (or any other key).

END OF EXAMPLE #4.

ASSIGNMENT GROUPS

IMPORTANT: These are general lists to help you identify the types of movements or lights in each group. The lists on your system may differ from these examples and other shows' lists.

PNEUMATICS for MITZI, BILLY BOB, FATZ, DOOK, & BEACH BEAR

MOUTH (open)
LIP (down)
HEAD TURN (right)
HEAD DOWN
HEAD TILT RIGHT
HEAD TILT LEFT
BODY TURN RIGHT
BODY TILT RIGHT
BODY TILT LEFT
KNEE BEND
WRIST RIGHT
WRIST LEFT
ELBOW RIGHT
ELBOW LEFT
ARM TWIST RIGHT
ARM TWIST LEFT
ARM RAISE RIGHT
ARM RAISE LEFT
SHOULDER RIGHT (raise)
SHOULDER LEFT (raise)

PNEUMATICS for LOONEY BIRD - LAB

MOUTH (open)
LIP (down)
HEAD TURN (right)
HEAD DOWN
HEAD TILT RIGHT
HEAD TILT LEFT
WRIST RIGHT
WRIST LEFT
ELBOW RIGHT
ELBOW LEFT
ARM TWIST RIGHT
ARM TWIST LEFT
SHOULDER RIGHT (raise)
SHOULDER LEFT (raise)
BODY TURN (right)

PNEUMATICS for LOONEY BIRD - WINDOW

MOUTH (open)
LIP (down)
HEAD DOWN
HEAD TURN (right)

SERVOS for all characters

EYES RIGHT
EYES LEFT
EYES DOWN
EYES UP
LIDS CLOSE
LIDS OPEN
EARS (for Mitzi and Dook only)

PROPS

COMPUTER SWIVEL (turn Looney's monitor)
BBEAR WINDOW (window that hides Looney's head)
COCONUT DROP (above Beach Bear's head)
SPEAKER LEFT (both left prop speakers)
SPEAKER RIGHT (both right prop speakers)
RABBIT EARS TOP LEFT (on big TV)
RABBIT EARS TOP RIGHT (on big TV)
RABBIT EARS BOTTOM LEFT (on big TV)
RABBIT EARS BOTTOM RIGHT (on big TV)
APPLAUSE SIGN (over Karaoke stage)
KARAOKE SPOT (aimed at singer)

CONTROLS

TURN STAGE RIGHT (Beach Bear / Looney Lab stage)
TURN STAGE LEFT (Dook / big TV stage)
STAGE RIGHT CURTAIN
STAGE LEFT CURTAIN
CENTER STAGE CURTAIN
BBOB BODY TURN RIGHT (Toy show only)
BBOB BODY TURN LEFT (Toy show only)

STAGE LIGHTS

STAGE RIGHT SPOT (character face spot)
CENTER STAGE RIGHT (character face spot)
CENTER STAGE CENTER (character face spot)
CENTER STAGE LEFT (character face spot)
STAGE LEFT SPOT (character face spot)
ROCKAFIRE NEON
EXPLOSION NEON
RIGHT FLOOR SPOT (overhead spot on stage-right)
LEFT FLOOR SPOT (overhead spot on stage-left)
NOTE #1 (yellow)
NOTE #2 (blue)
NOTE #3 (pink)
NOTE #4 (purple)

COLOR AND STROBE LIGHTS

COLOR LIGHT #1 (center stage effect)
COLOR LIGHT #2 (center stage effect)
COLOR LIGHT #3 (center stage effect)
COLOR LIGHT #4 (center stage effect)
COLOR LIGHT #5 (center stage effect)
COLOR LIGHT #6 (center stage effect)
COLOR LIGHT #7 (center stage effect)
COLOR LIGHT #8 (center stage effect)
COLOR LIGHT #9 (center stage effect)
STROBE (over center stage)
LOONEY SET LIGHT (window light)
DOOK WINDOW (light in house's window)

CLEAR THIS SWITCH

Clears any assignment for the switch indicated near the top-left of the screen. Clears only this switch and no others that may be assigned.

Adjust Turntables

This utility function is used for checking the speeds of the three character (small) turntables and the large turntable, all of which are driven by air motors. If you don't understand how these turntables operate, please read the CHARACTER TURNTABLES and LARGE TURNTABLE sections of the manual.

CW = Clockwise CCW = Counterclockwise

When you choose a button from the menu that sends a turntable to its fully CW or fully CCW position, the system counts the number of seconds the air motor is turning the table until the table reaches the point where the infrared readers shut off the motor. The reading will only be accurate if the table is turning from one extreme position to the other, i.e., not starting out somewhere in between its fully CW and fully CCW position. Please see the WEEKLY maintenance schedule in the MAINTENANCE section of the manual for ideal turntable speeds.

Keep in mind that the turntable mechanisms will initially rotate a bit slower than normal if they haven't been running in the past few minutes. When checking a turntable's times, always cycle the table from one extreme to the other (CW to CCW, CCW to CW, etc.) a couple times without paying attention to the readings. This will not only loosen up the mechanism, it will also insure that the table will be traveling from one extreme position to the other when you begin noting the readings.

Also remember that when adjusting the speed of one direction, it will have a slight affect on the speed of the other direction. Always make sure you have two or three good readings in both directions before moving on.

For shows with Karaoke, this utility can be operated from the Karaoke menu as well as at the computer.

The main panel is shown on the next page.

63
03

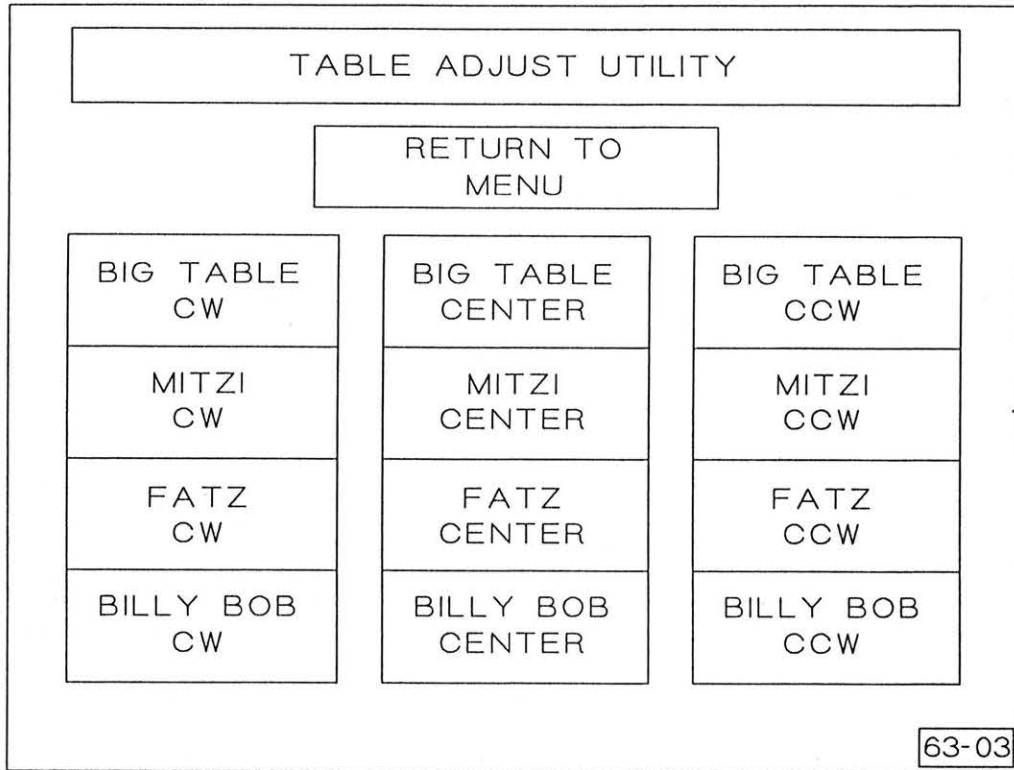

INFO: From this main panel, you can instruct any of the four turntables to go to its fully CW, fully CCW, or CENTER position.

ACTIVE BUTTONS: 13

Choosing any *CW* or *CCW* button will start the table turning and show you the timer screen shown on page 3.

Choosing any *CENTER* button will start the table turning and show you the screen shown on page 4.

RETURN TO MENU: Returns to the main menu panel of the Show Adjustment Utilities.

06.1

PRESS SPACEBAR OR CLICK PEN FOR MENU

When this screen first appears, the table will most likely still be rotating, and there will be no time reading displayed on the screen. After the table stops, the system will display the reading on the screen, rounded to the nearest tenth of a second. The timer for the character turntables has a maximum of 10 seconds, so if the table takes more than 10 seconds to get to get to where it's going (which is way too slow), the timer will stop at 10 seconds and display 10.0 on the screen. (The big table's timer has a maximum of 20 seconds.)

If the character turntable was already at the position you were attempting to send it to, the table won't move at all. In this case, the timer will run up to the 10 second maximum and stop, displaying the 10.0 on the screen. (The same is true of the big table, except the timer will run up to the 20 second maximum.)

After the timer reading appears, this screen will remain on the monitor until you press the spacebar (or the Karaoke push-button if your show is so equipped), which returns you to the main panel shown on page 2.

Position Characters In Front

This utility function is used for checking the positioning feature of the center stage turntables - the three character (small) turntables and the large turntable. If you don't understand how these turntables operate, please read the CHARACTER TURNTABLES and LARGE TURNTABLE sections of the manual.

CW = Clockwise CCW = Counterclockwise

By pressing a single key of the keyboard, you command the system to rotate the large turntable to position any one character or any two characters up front (toward the audience). When a single character is sent up front, the character should be front-and-center (or very close to it). When two characters are sent up front, the two characters should be an equal distance from the center line of the stage (or very close to it). In either case, regardless of where the large turntable stops, the system will have rotated the three individual character turntables so that the characters themselves should be facing directly forward (or very close to it).

The phrase "or very close to it" is added because the system recognizes the fact that the turntables coast a bit after the air motor is shut off. Consequently, the system shuts off the air motor just before the table reaches the target position, and relies on the coasting to bring the table to its mark. Depending on the tightness of the table and the table's speed, the amount of coasting can vary slightly. However, under normal conditions, you can expect the table to stop within 5 degrees on either side of the target position.

NOTE: 5 degrees on a character turntable is roughly 1 inch along the circumference of the table. 5 degrees on the large turntable is roughly 5 inches along its circumference.

Should a table not stop within 5 degrees of the target position, then consider the following:

- 1) If the table is stopping a little bit short of the target area, check the table's speed by using ADJUST TURNTABLES.
- 2) Similarly, if the table is stopping a little beyond the target area, check the table's speed by using ADJUST TURNTABLES.
- 3) If the table(s) are stopping nowhere near the proper positions, the table(s) is most likely out of sync. In this case, following the instructions in the CHARACTER TURNTABLES or LARGE TURNTABLE section of the manual to check the sync of the table in question.

Keep in mind that the turntable mechanisms will initially rotate a bit slower than normal if they haven't been running in the past few minutes. To "loosen up" the tables, choose a few options at random from the menu screen (shown on the next page) to exercise the tables. Then choose the positions you are interested in checking.

The menu screen is shown on the next page.

ESCAPE TO EXIT PROGRAM

0. STOP TABLE
1. BBOB FRONT (CW)
2. BBOB & MITZI FRONT
3. MITZI FRONT
4. FATZ & MITZI FRONT
5. FATZ FRONT
6. BBOB & FATZ FRONT
7. BBOB FRONT (CCW)
8. BBOB BY TV (CCW)

SELECT OPTION

This screen uses keyboard input only (no lightpen). Simply press a number key from 0 to 8 to command the system to send the large turntable to the position indicated. When you are through, press the ESC key.

CHOICES: 10

0. STOP TABLE: Pressing the 0 key will instantly stop the large table wherever it is when you press 0.

1. BBOB FRONT (CW): Billy Bob has two front-and-center positions. This is the CW one, which, by the way, is the large turntable's fully clockwise position.

2. BBOB & MITZI FRONT: Billy Bob and Mitzi equal distances from the center line of the stage.

3. MITZI FRONT: Mitzi front-and-center.

4. FATZ & MITZI FRONT: Fatz and Mitzi equal distances from the center line of the stage.

5. FATZ FRONT: Fatz front-and-center.

6. BBOB & FATZ FRONT: Billy Bob and Fatz equal distances from the center line of the stage.

7. BBOB FRONT (CCW): This is Billy Bob's other front-and-center position. From this position, the large turntable is capable of rotating one full revolution clockwise to get to BBOB FRONT (CW), or rotating about 45 degrees counterclockwise to get to BBOB BY TV (CCW). This position, BBOB FRONT (CCW), is the standard starting position of the large table.

8. BBOB BY TV (CCW): This places the large turntable at its fully CCW position, which puts Billy Bob close to the large screen TV.

ESC: Returns to the main menu panel of the Show Adjustment Utilities.

Read Turntable L.E.D.'s

This is a simple utility that indicates the present position of the four center stage turntables - the three character (small) turntables and the large turntable. If you don't understand how these turntables operate, please read the CHARACTER TURNTABLES and LARGE TURNTABLE sections of the manual.

The system continues to monitor the position of all four tables and displays the positions on the screen. If you manually move any table, the position displayed on the screen will change.

To better understand the position numbers that this utility displays, please read Turntable Positioning Exercise in this section of the manual.

IMPORTANT: If you plan on manually (by hand) rotating tables to check the system's ability to read position numbers, always remember the CAUTION's detailed in the CHARACTER TURNTABLES and LARGE TURNTABLE sections of the manual:

- 1) Turning a character table too far in either direction can damage the "stop" mechanism.
- 2) Turning the large table too far in either direction can trigger the limit switch.

The screen for this utility is shown on the next page.

CENTER TABLE	01
MITZI TABLE	07
BILLY BOB TABLE	07
FATZ TABLE	07

PRESS ANY KEY TO RETURN TO MENU

This screen shows the current location of the four center stage, motor-driven turntables. The character turntable positions are numbered 0 through 14, with the number 15 reserved to indicate that the table is in between readable positions. Similarly, the large (center) table positions are numbered 0 through 30, with the number 31 reserved to indicate that the table is in between readable positions. All turntable position numbers increase when the table is rotating CW, and decrease when the table is turning CCW.

Pressing any key of the keyboard will return to the main menu panel of the Show Adjustment Utilities.

TECHNICAL NOTE: When Billy Bob is at his CCW front-and-center position, the large table is at or near its number 1 position. A little farther CCW is the number 0 position. However, the fully CCW position of the large table (where Billy Bob is over by the TV) is about 30 degrees farther CCW than the number 0 position. Though there are no readable position numbers in this area (number 31 is displayed), the system is capable of sending the large table to its fully CCW position by rotating the large table CCW for "X" number of seconds after passing the 0 position.

Cycle And Time Tables

This utility function is used to thoroughly cycle and check the speeds of the three character (small) turntables and the large turntable, all of which are driven by air motors. Unlike the Adjust Turntables utility where you command the table to rotate one direction at a time, this utility simulates the conditions of actually running a show, while averaging the amount of time it takes for the table to travel from one extreme position (CW or CCW) to the other. If you don't understand how these turntables operate, please read the CHARACTER TURNTABLES and LARGE TURNTABLE sections of the manual.

CW = Clockwise CCW = Counterclockwise

When you choose a button from the menu, the system will automatically cycle the table you've chosen 10 times. Rotating fully to one extreme position (CW or CCW), then back to the other extreme constitutes one time. After the system finishes cycling the table, it reports the average time for each direction.

The system recognizes the fact that the turntable mechanisms will initially rotate a bit slower than normal if they haven't been running in the past few minutes. The system also knows that the table will probably start out somewhere in between the two extremes on the first cycle. Therefore, for both reasons, when calculating the average times for a table, the system "throws out" the first couple readings for each direction.

If either of the turntable's average times is unacceptable, use the Adjust Turntables utility to rotate the table one direction at a time while making adjustments.

The main panel is shown on the next page.

63
04

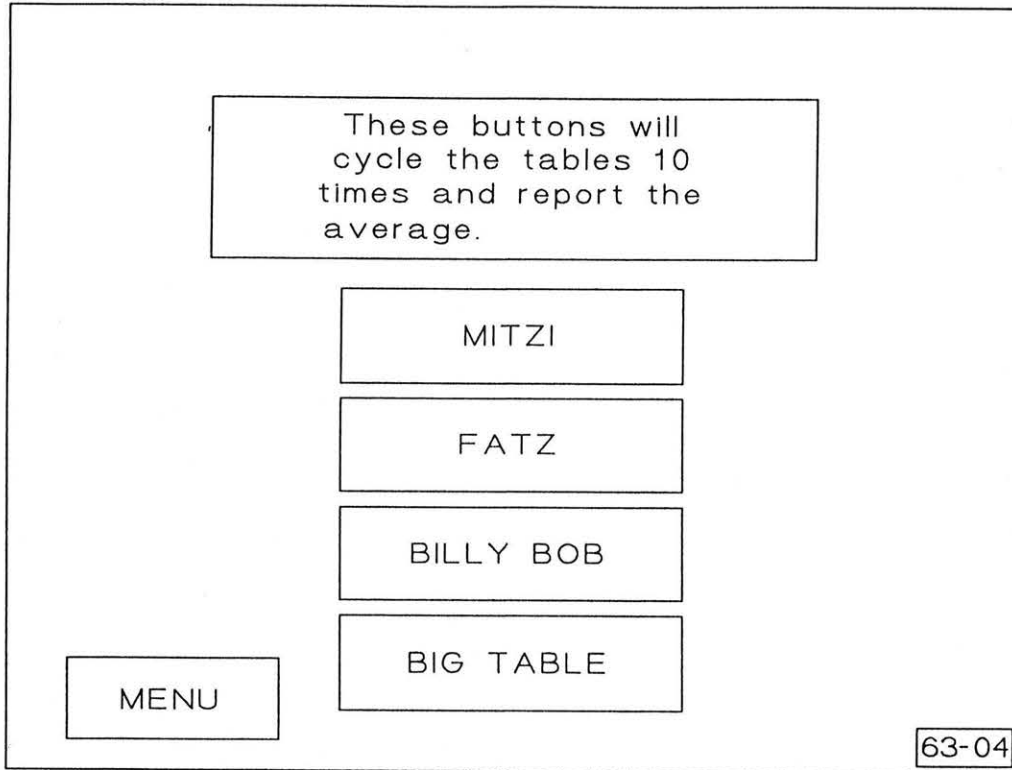

INFO: From this main panel, you can command the system to cycle any of the four turntables of the center stage. Pressing any button (except *MENU*) will take you to the screen shown on the next page.

ACTIVE BUTTONS: 5

MITZI: Begins cycling the Mitzi turntable and shows you the timer screen shown on the next page.

FATZ: Begins cycling the Fatz turntable and shows you the timer screen shown on the next page.

BILLY BOB: Begins cycling the Billy Bob turntable and shows you the timer screen shown on the next page.

BIG TABLE: Begins cycling the large turntable and shows you the timer screen shown on the next page.

MENU: Returns to the main menu panel of the Show Adjustment Utilities.

CW	06.0
CCW	06.1

When this screen first appears, the table will begin rotating, and there will only be a zero time reading on the screen. Each time the table briefly stops at the end of each direction's rotation, the system will flash that particular reading on the screen, rounded to the nearest tenth of a second (in case you want to stand there and watch the readings). After the system has finished cycling the table 10 times, it will display the average times for each direction on the screen as shown in the example above.

After the timer readings appear, this screen will remain on the monitor until you press the spacebar, which returns you to the main panel shown on page 2.

position, the table can be turned roughly three-quarters of a revolution in either direction before hitting a mechanical stop mechanism that prevents the table from going any farther.

2) Press ESC to exit this screen, then at the main menu again, choose READ TURNTABLE L.E.D's. On the next screen, the names of the four air motor-drive turntables are listed along with a position number to the right. (For the moment, we aren't interested in center table.)

3) Assuming the characters' positions resemble the diagram 3A, each character table should be at position 7 or close to it. Having one person read the monitor and another on the center stage, start with Mitzi by verifying the center position of 7. If the readout isn't 7, move the table a little, one way or the other, until it does read 7. There should be a center mark or line on the character turntable itself, under the edge of the carpet, showing the front-and-center spot of the table - if not, make one with a permanent marker. (The center spot of a character table is where a line, exactly between the legs and perpendicular to the legs, hits the edge of the table in front of the character; thus, the term front-and-center.) Now, with help from the person watching the monitor, move the table one way until you reach the exact point where you loose the 7, then move the table the other way until you reach the other point where you loose the 7. Between these two points is the "range" of position 7, and exactly in the middle of the range is the exact front-and-center position. At the middle of the range, place a small, permanent mark on the stage (where it will be hidden under the carpet) directly across the gap from the center mark on the table, then label the stage mark "CTR-7" for center. (These marks will prove to be very useful should you ever need to perform repairs on a character turntable!)

NOTE: The average "range" of a position will be roughly two inches in length along the circumference of the table.

4) Spin Mitzi's table 3/4 revolution counterclockwise (slowly!) to find the range of position 0, locate the middle of the range (like above) and mark it "CCW-0."

5) Spin Mitzi's table 1 1/2 revolutions clockwise (slowly!) to find the range of position 14, locate the middle of the range (like above) and mark it "CW-14."

6) Repeat the process of marking the 0, 7, and 14 positions for Billy Bob and Fatz.

THE CHARACTERS

The characters in your show are designed and built with two things in mind: long life and minimal maintenance. However, it is important that you realize up front that those two things go together - the long life is dependent upon your attention to the maintenance. If it were possible to build a moderately-priced, maintenance-FREE character containing all the movements our characters do, we would do it. The fact is that all mechanical devices in the world always have, and likely always will, require some type of maintenance. All products with moving parts, from roller skates to space shuttles, will undergo a certain amount of normal wear and tear over time. Equally so, all such products, when NOT properly maintained, will usually suffer from poor performance and/or breakdowns.

Because your characters require some routine attention, it's important that you understand the basic design of the individual character. The component parts that make up the mechanical structure of the character are made of various materials: mostly aluminum, steel, and plastics. The plastic parts are used for several reasons. They are lighter in weight, less expensive to make (usually), and work very well in friction-producing areas like pivot points.

Aside from the masks and costumes/clothing of each character which are obviously quite different for each; for the most part, the characters are mechanically identical. The servo movements in the head, which control the eyes and eyelids, are the same in every head. With the exception of Looney Bird, the first 20 pneumatic movements of each character are also the same. (Mitzi and Dook have an optional 21st pneumatic movement for the ears.) Looney Bird has only 15 pneumatic movements, so the other 5 valves of Looney Bird's valve bank are used to control the pneumatics in the Looney Bird "window head" (in the window next to Beach Bear), and Looney Bird's monitor swivel.

The first three columns of charts 2A and 2B (following this section) list the cylinders and rotary actuators for each character, named according to their movement. Listed along with each movement is the type (cylinder or rotary actuator) and valve number of each movement. The valve number indicates which valve of the character's valve bank actuates the movement. Chart 2A applies to all characters except Looney Bird. Looney Bird's movements are listed on Chart 2B.

As mentioned above, your Mitzi and/or Dook may have an active 21st valve controlling the ears. As for Looney Bird, due to the constraints of being behind his desk, five of the standard movements are not used for him. These five eliminated movements are both *arm raises*, both *body tilts*, and the *knee bend*.

CYLINDERS AND ROTARY ACTUATORS:

The pneumatic actuators used for the movements vary by way of design and construction. Most of the movements are driven by linear actuators that have cylindrically-shaped bodies with a piston rod extending from one end that travels straight out (extended) and straight back (retracted), and are simply referred to as "cylinders." However, there are three movements that use a non-linear actuator: *head turn right*, *right arm twist*, and *left arm twist*. These movements rely on "rotary actuators" which are box-shaped pneumatic devices used to twist things to which they are attached. Rotary actuators have a length of shaft extending from one end that is specifically designed to NOT move in or out at all, at any time. The shaft, instead, rotates a certain number of degrees, e.g., a 90 degree rotary actuator turns 1/4 turn from stop-to-stop.

LUBRICATION - The cylinders and rotary actuators are lubricated in two ways. They are pre-lubricated during assembly at the factory and are, thereafter, lubricated by the automatic oilers attached to the main air manifold. These oilers automatically inject a very small amount of hydraulic oil into the air as the air passes through. (There are also oilers on the manifold to lubricate the air going to the "air motors" that rotate the character turntables and a separate oiler for the air motor that drives the large turntable.) The cylinders and actuators are designed to cycle hundreds of thousands of times, or even more, before requiring service.

CYLINDERS - A typical cylinder consists of a round body of equal diameter from one port to the other (the port is the threaded hole into which the hose fitting is screwed), and a threaded shaft extending from one end that is attached to a piston that travels within the cylinder (see diagram 2C). When air pressure is applied to hose attached to one port, the piston is forced toward the other port, which is un-pressurized. The speed of the piston movement is controlled by limiting the rate at which the air is allowed to escape through the hose attached to the un-pressurized port. The mechanism used to limit the rate is called a "flow control" (described later).

In each cylinder there are two seals. The seals are specially-made rubber O-rings that do two things: they prevent the piston and shaft from making direct contact with the inside walls of the cylinder body; and, at the same time, prevent air from leaking past the piston (called "blow-by") or between the shaft and the inside of the nose of the cylinder. If either seal becomes excessively worn or damaged, the cylinder will need to be repaired or replaced. Charts 2A and 2B denote rebuildable cylinders with ** after the name. The other cylinders are maintenance-free and cannot be rebuilt (they don't come apart); therefore, they must be replaced.

The most common reason for premature cylinder wear is "side-load." Side-load is a condition where, for one reason or another, the piston shaft is pushed or flexed sideways while the piston is moving. This side-load causes the shaft to rub abnormally hard against one area of the inside of the nose of the cylinder. Since the nose seal is in this area, it too is worn at an accelerated rate at that particular spot where the shaft is being forced to rub on it more than normal. Due to mechanical leverage, if side-load occurs, the piston (and seal) will also be forced to rub abnormally hard against the inside surface of the cylinder body. As you might imagine, under side-load conditions, it won't take long for the seals of a cylinder to deteriorate and begin leaking. Even worse, if the side-load is severe enough, the piston and shaft can actually scrape the interior surfaces of the cylinder, causing the movement to stick or stop altogether. Some hints regarding side-load are discussed later in this section.

ROTARY ACTUATORS - A typical rotary actuator has a box-shaped body and a short shaft extending from one end (see diagram 2D). The ports are next to each other on the end opposite to the extended shaft. Since the purpose of the rotary actuator is to turn or twist whatever is attached to the shaft, the shaft runs from one end to the other and rides on needle bearings at each end of the actuator. These needle bearings are used because side-load is practically guaranteed in rotary movements - that is, the rotary actuator is designed to handle it.

The interior of the rotary actuator is difficult to appreciate without actually seeing it. The shaft, inside the central part of the actuator, has two vanes, one opposite the other. The vanes are rectangular-shaped plates that are attached to the shaft and seal against the curved interior surface of the actuator. When air pressure is applied to hose attached to one port, pressure builds up behind one vane and forces the shaft to rotate, as the air on the other side of the vane is allowed to escape out the other port, which is un-pressurized. The speed of the rotation is controlled by limiting the rate at which the air is allowed to escape through the hose attached to the un-pressurized port. The mechanism used to limit the rate is called a "flow control" (described later). Rotary actuators aren't particularly strong; consequently, they are only used in movements that don't require a lot of heavy lifting (opposing gravity).

Though not very powerful, rotary actuators are very reliable - they should function for years and years on end. The seals in the rotary actuator are very complex and [without experience] difficult to properly service. If a rotary actuator should malfunction, it is recommended that you order a new or rebuilt one. (The tolerances within rotary actuators are such that attempts to rebuild them can result in wasted time and money.)

VALVE BANKS:

As mentioned earlier, there are 20 movements on the average character. Charts 2A and 2B list the movements by name. The charts also denote the type of mechanism used (cylinder or rotary actuator), which cylinders are rebuildable, and which valve number applies to each movement. Each character has a "valve bank" which is actually a base board with two banks of valves interconnected with air hoses and wires. The valve banks for all characters are plumbed and wired alike with the exception of Looney Bird (compare charts 2A and 2B). Each individual valve is shifted by an electric solenoid that is bolted directly to the valve and has two black wires connecting the solenoid to a small PC board mounted between the two banks of valves. The solenoids operate on 24vdc and are triggered by the bit-stripper, which in turn receives data from the computer.

NOTE: Each valve also has an override button to allow for manual operation during maintenance. It's a small, white, recessed button on the outside of the valve that can be pushed with a small screwdriver to manually shift the valve.

The valves are used to control the air flow to and from the cylinders (and rotaries). Since all pneumatic movements rely on pressurized air, each valve bank is supplied by a main air line with a female quick-connect that's attached to a "T" connector on the valve bank hoses. At that point, the air splits off in opposite directions and feeds both banks of valves at the main "inlet" port at the end of each bank. Similarly, each bank has a main "exhaust" port (next to the inlet) where the air comes back out of the banks and routed to another "T" connector attached to a muffler to dampen the noise.

The simple responsibility of the valve is to make the cylinder (or rotaries) move. When the valve is at rest, the pressurized air (80 psi) is directed out the **B** port of the valve, through the air hose, to one port of the cylinder. If this happens to be the front port of the cylinder, the piston inside would be forced toward the rear end of the cylinder until it stops. The air that was behind the piston escapes out the rear cylinder port, through the other air hose, to the **A** port of the valve, where it is vented directly to the muffler. The cylinder, retracted in this case, is now in its "starting position." To keep things uncomplicated, when the valve is unshifted (at rest) and the cylinder is in its starting position, the movement is said to be OFF. When the movement is ON, everything is just the opposite - the solenoid is energized, the valve is shifted, and now the functions of the valve ports are reversed. The pressurized air is now directed out the **A** port, through the hose, to the rear port of the example cylinder. The piston is forced to the nose-end of the cylinder and the air in front of the piston escapes out the front port, down the hose, to the valve's **B** port which is now vented to the muffler.

POSITIONS:

For each movement, there are two positions: movement OFF (starting position) and movement ON. As you can imagine, if the air hoses to a cylinder get reversed, the movement's positions will be backwards. For example, when the hoses between valve number 12 and the left elbow cylinder are properly connected, the OFF position of the cylinder is "extended" (the shaft is out as far as it goes) and the elbow is not bent. The ON position has the cylinder "retracted" and the elbow is bent. If the hoses were to be accidentally reversed (during repair or maintenance), the elbow would start out bent and then straighten when the movement is turned ON - obviously backwards.

The last two columns of charts 2A and 2B show the movement OFF positions of the cylinders/rotaries as well as the OFF positions of the character's actual body movement. When ALL the movements are OFF, and everything is working properly, the character will be in proper "stance." Knowing the proper stance will make it easier to spot potential problems before they progress. The actual position of the cylinder or rotary itself is only helpful when the costume is removed, since they are otherwise not visible.

NOTE: When working directly with a cylinder, using the override button on the valve to cycle the cylinder a couple times makes it easier to determine the retracted and extended positions. The positions of a rotary actuator are clockwise (CW) and counterclockwise (CCW), determined by cycling the movement and looking at the rotary from the shaft end (the shaft pointing directly toward you).

FLOW CONTROLS:

A flow control is a small mechanical device used to control or "meter" the flow of air through a hose in one direction only. ALL pneumatic movements in the show have two flow controls - one for each direction of the movement (including curtains, props, and turntables). All flow controls, regardless of size or shape, work the same way. They have an adjustable screw to control the flow of air going one direction, and a bypass valve that allows air to flow the other direction completely unrestricted. The entire purpose of the flow control is to control the speed of a movement by metering the speed of the air going through the air hoses. Flow controls are absolutely necessary for smooth, fluid movements in the characters, stages, curtains, etc. Your first guess might be that the flow control meters the air going toward the cylinder when during the movement - but it doesn't. The flow control on the hose carrying air toward the cylinder (or rotary, air motor, etc.) allows the air to pass through completely unrestricted. The flow control on the hose carrying air AWAY from the cylinder (back to the valve bank) is doing the metering, that is, controlling the flow of air.

Understanding flow controls, and how to adjust them, is critical regarding the function of your show. There are basically three styles of flow controls, described below:

1) Built-In: Many of the valves in the character valve banks have both flow controls built right in, one flow control for each direction. To be exact, valves 3 through 17 of each character valve bank have built-in flow controls (the rest do not). Being built-in, the only thing visible and accessible to you are the adjustment screws located on the outside of the valve just below the override button. The two screws are consistent with standards; that is, turning the screw in (CW) decreases the flow and turning the screw out (CCW) increases the flow. The screw on the left controls the speed of the ON movement, and the screw on the right controls the OFF movement.

2) FC-32: FC-32 flow controls are in-line flow controls used to control character movements that don't have built-in flow controls. FC-32's are roughly one inch square and about a 1/4 inch thick with a thumb screw extending from one side. In addition, there is an arrow imprinted on the side to show in which direction the air is metered. These arrows are always pointing away from the cylinder and toward the valve bank. Movements that utilize FC-32's are listed here, along with the physical location of the FC-32's.

--- Billy Bob, Fatz, Mitzi, Beach Bear, Dook ---

#1	Mouth	-	behind neck block
#2	Lip	-	" " "
#18	Body tilt left	-	directly before cylinder
#19	Body tilt right	-	" " "
#20	Knee bend	-	" " "
#21	Ears (Dook/Mitzi)	-	behind neck block

--- Looney Bird Only ---

#1	Mouth	-	behind neck block
#2	Lip	-	" " "
#18	Lip (window head)	-	behind neck block (window head)
#19	Mouth (window head)	-	" " " "
#20	Monitor swivel	-	under desk near swivel rotary

FC-32's are not normally marked to show which is for the ON and which is for the OFF movement, but simple trial-and-error will indicate which is which during adjustment.

3) High-volume: High-volume flow controls are not used on the characters themselves; rather, they are used for movements that require large volumes of air which include the curtain cylinders, side turntable cylinders, large turntable air motor, and character turntable air motors. They are in-line like FC-32's but much larger, barrel-shaped, and have a locking nut on the thumb screw.

MOVEMENT SPEEDS:

Adjusting the speed of each movement is accomplished through adjusting the two flow controls for each movement. As mentioned above, most flow controls are built-in, while others are actually inside the character near the cylinder. The characters have been designed, for the most part, to move at the same speed as a human might. Some movements are faster than others. For instance, short movements like the *mouth*, *lip* and *wrists* will be rather quick since the parts being moved are short or very light - just as with humans. Movements with long parts or heavy lifting duties will be slower, like *arm raises*, *shoulder raises*, and *body tilts*. If a movement is too slow, it will look unrealistic and affect the choreography of the show. Even worse, if the movement is too fast, not only will it look bad and not match the other characters, but it can cause severe damage to the character.

Built in to each end of the cylinder (inside) are rubber bumpers (or buffers) that prevent the piston from making metal-to-metal contact with the cylinder housing at the end of each stroke. And since the rubber is slightly compressible, it also serves to cushion the piston to a stop during the last few thousandths-of-an-inch of travel. Though not visible to the naked eye, that little bumper also cushions the stopping of the arm, or head, or whatever is being moved. All in all, the movement should be relatively silent when it reaches the end of the travel, i.e., no banging or clacking noises that indicate that it is stopping too abruptly because it's traveling too fast. If the piston and, for instance, the arm to which it's attached are travelling faster than normal, when the piston slams into the bumper, the cushioning ability of the small bumper will be momentarily overpowered, causing the piston and the arm to stop instantly causing the banging noise (and possibly damage). This condition is often referred to as "slamming," and is completely undesirable. Movements that "slam" not only look bad, but shorten the life expectancy of the parts involved.

Analogy: Imagine a sheet of rubber about 1/2 inch thick on a wooden coffee table. A bowling ball is suspended by a rope three feet above, then lowered at a steady, moderate rate (let's say one foot per second) until it contacts the rubber mat and stops. The rubber would be able to absorb the impact of the ball. There would be relatively little noise (if any), and the table would not be damaged. Now, with the bowling ball back up to three feet above the table, this time cut the rope. By the time the ball hits the rubber, it's velocity will be roughly 13.8 feet per second. The rubber cannot absorb the impact, so the force of the ball is transferred to the table - end of table! This example is a bit extreme, but the point should be clear - the speed of each character movement can only be so fast until the momentum of the moving parts overpowers the bumper, which causes slamming.

SPEED ADJUSTMENTS- The most reliable way to correctly adjust the speed of each movement is to use the supplied Adjustment Video Tape (still being developed as of 08/01/95). This tape automatically cycles the movements of each character while showing a properly adjusted character on the TV screen that your character should match. The instructions for using the tape are under separate cover and come with the tape itself. Keeping the characters properly adjusted is important to maintain the choreography of the show. All *arm raises* should be set the same, all *body tilt* speeds the same, etc. Remember - a movement that is too slow looks bad; a movement that is too fast not only looks bad, but can cause expensive damage.

PIVOT POINTS:

For every character movement involving a cylinder, there are three pivot points - the apex, the front mount, and the rear mount (see diagram 2E). The apex is the point where the two involved body parts are actually connected to each other. For example, the apex of an *elbow* movement is the elbow joint itself - the pivoting joint where the upper arm meets the lower arm to form a hinge. The apex of the *body tilt* movements is the large universal joint in the center of the character. The front mount is where the cylinder shaft rodend (or clevis) meets the lower arm near the wrist area. The rear mount is, of course, the point where the rear of the cylinder attaches to the upper arm. If any one of the three points is not free to pivot properly, the movement will stick or seize instead of moving smoothly and fluidly.

Though the pivot points of the seventeen cylinder-based movements of a standard character differ in size and shape, there are only four "types" of pivot points used: shaft-and-bearing, floating pin, ball joint, and universal joint. All four are briefly outlined below:

1) Shaft-and-bearing: There are four movements that utilize this type of pivot for their apex. The left and right *shoulder raise* cylinders each attach to a lever that is permanently affixed to a shaft that spins in the plastic shoulder block (the bearing) and rotates the arm upward when the movement is ON. Next is the *body turn right* movement. The shaft that extends downward from the large universal joint in the center of the character spins inside oil-impregnated bearings pressed into the two-piece plastic hip block, allowing the entire body above the hip to rotate left or right. The last one is the *knee bend*. The apex of the *knee bend* is where the lower leg bars pass through the plywood base at the character's feet. There are two foot plates attaching each leg to the plywood. Each leg (with pressed-in oil-impregnated bearings) spins on a fixed hollow shaft that is bolted tightly in place between the two foot plates. NOTE: Looney Bird has no *knee bend* movement.

2) Universal joint: There are two. Universal joints serve as the apex for two movements simultaneously. There is a large universal joint connecting the lower body shaft and upper body shaft that allows the *body tilt left* and *body tilt right* to be used in any combination. Similarly, there is a smaller universal joint in the neck region that allows the combined usage of both *head tilt* movements. NOTE: Looney Bird does not have *body tilt* cylinders; hence, the large universal joint does not pivot.

3) Ball joint: A ball joint pivot is actually a ball-in-socket joint, much like the hip joint of a human or a ball joint on a car's front suspension. The socket is free to spin about the ball even with small angles of deflection during the movement, i.e., things aren't always traveling exactly in a straight line, like the human hip joint that allows for the leg to go forward, backward, out, and in, and any combination therein. Ball joints are currently used ONLY for front and/or rear pivot points, and are not used for any apex pivots. The unique characteristic of a ball joint is that the ball (in which there is a hole for a bolt to pass through) should remain fixed. Since the socket is free to pivot at various angles around the ball, the ball should be locked in place by firmly tightening the bolt that attaches the ball (in the ball joint) to the other mechanisms of the character. There are five movements on each character that utilize the ball joint for their front and rear pivot points. They are the *head tilt left*, *head tilt right*, *body tilt left*, *body tilt right*, and *body turn right*. NOTE: Ball joints are also used for attaching the leg adjustment rods on the back side of each lower leg (except for Looney Bird - his knees don't bend).

4) Floating pin: This is the catch-all category, which simply means that any pivot point not listed above is a floating pin pivot. Floating pins can be only one of three different types that are easily recognizable. First is the steel dowel pin that is held in place by shaft collars (two or more). The shaft collars are tightened in place so that the "end play" of the pin (the distance the pin can actually slide from side-to-side) is kept to a minimum, yet the pin can still be turned (spun) by hand, or at least with VERY little effort using tools. Second is a steel dowel pin that doesn't require shaft collars. They have a spring-loaded ball or clip that keeps them from coming out instead of shaft collars. The third, and most popular, is the aircraft bolt/locknut combination. The aircraft bolt is used for the exact same purpose as a steel dowel pin - it must be free to spin within the pivot point. It may be a "bolt" but it should not be torqued tight - it is still a floating pin. Why use an aircraft bolt instead of a pin? Simple - the aircraft bolts are made to close tolerance (like a dowel), and they have a threaded end to allow you to tighten the locknut little-by-little to eliminate unnecessary end play without tightening it all the way - thus retaining the feature of a floating pin.

NOTE: Locknuts are used extensively, in their normal capacity, throughout the characters for tightly bolting parts together,

often with a lock nut as well. These locknuts (and bolts) should be tight. ONLY locknuts used at pivot points should be just loose enough for the bolt to spin.

CAUTION: When a locknut is used with an aircraft bolt to create a floating pin (as described above), never replace the locknut with a regular nut and lock washer - the results are NOT the same. The unique characteristic of the locknut is the nylon ring imbedded at the top of the threads that grips the threads of the bolt tight enough to prevent the nut from moving, even when it's left "loose" enough to allow the bolt to spin (function as a floating pin). On the contrary, a regular nut would have to be tightened all the way to prevent it from vibrating loose, but that's out of the question since the bolt would then not be free to spin!

SERVOS MOTORS:

Referred to simply as "servos," there are three used in each character head, each one controlling two movements that are opposite each other. One is used for *eyes left* and *eyes right*, one for *eyes up* and *eyes down*, and the third for *eyelids open* and *eyelids close*. Unlike cylinders and rotary actuators, the speed of the servos is not adjustable. The speed of a servo and the amount it spins in both directions are all controlled electronically by the bit-stripper. The cable that runs from the bit-stripper board, up through the character to the head, carries the power and control signals to the servos.

A servo has a center position where, for instance, the eyes are looking straight ahead (not left or right). The bit-stripper then sends a variable signal to rotate the servo one way or the other - in this case, causing the eyes to turn left or right of center. The other two servos work the same way.

The two most common causes of servo malfunction can both be prevented -

1) Cable pulled away from bit-stripper board: When removing or replacing the valve bank, carefully insure that the three cables from the bit-stripper are safely routed and won't be pinched or pulled.

2) Mask rubbing eyelids or eyes: As outlined in the MAINTENANCE section, when the mask is fit properly, the eyes should not be rubbing the mask, otherwise the mask will create a "drag" on the servos - something the servos are not especially designed to handle. As for the eyelids, they should either clear the mask or barely touch it during operation. Eyelid lube is used to ensure that slight contact won't cause sticking that might damage the servo. Simply keep in mind that servos are used for movements that produce very, very little resistance - they are not designed to do any real "work," like a cylinder.

CHART 2A - VALVE BANK LAYOUT

BILLY BOB - FATZ - MITZI - BEACH BEAR - DOOK

Valve	Movement	Type	Movement OFF positions (starting positions)	
			cylinder / rotary	body movement
1	Mouth	cylinder	retracted	mouth closed
2	Lip	cylinder	extended	lip closed (up)
3	Head up **	cylinder	extended	NOT looking up
4	Head turn right	rotary	CCW	head turned left of center
5	Head tilt left	cylinder	extended	head level (NOT tilted)
6	Right wrist	cylinder	retracted	wrist straight (NOT bent)
7	Right elbow	cylinder	extended	arm straight (NOT bent)
8	Right arm twist	rotary	CW	palm facing in (NOT up)
9	Right arm raise **	cylinder	retracted	arm down
10	Right shoulder	cylinder	extended	arm down
11	Left wrist	cylinder	retracted	wrist straight (NOT bent)
12	Left elbow	cylinder	extended	arm straight (NOT bent)
13	Left arm twist	rotary	CCW	palm facing in (NOT up)
14	Left arm raise **	cylinder	retracted	arm down
15	Left shoulder	cylinder	extended	arm down
16	Head tilt right	cylinder	extended	head level (NOT tilted)
17	Body turn right **	cylinder	extended	body turned left of center
18	Body tilt left **	cylinder	extended	body vertical (NOT tilted)
19	Body tilt right **	cylinder	extended	body vertical (NOT tilted)
20	Knee bend	cylinder	extended	legs straight (NOT bent)
21	Ears (Mitzi)	cylinders	retracted	Mitzi ears straight up
21	Ears (Dook)	cylinders	extended	Dook ears down

** rebuildable cylinders

CHART 2B - VALVE BANK LAYOUT

LOONEY BIRD (character and window head)

Valve	Movement	Type	Movement OFF positions (starting positions)	
			cylinder / rotary	body movement
1	Mouth	cylinder	retracted	mouth closed
2	Lip	cylinder	extended	lip closed (up)
3	Head up **	cylinder	extended	NOT looking up
4	Head turn right	rotary	CCW	head turned left of center
5	Head tilt left	cylinder	extended	head level (NOT tilted)
6	Right wrist	cylinder	retracted	wrist straight (NOT bent)
7	Right elbow	cylinder	retracted	arm bent to chest
8	Right arm twist	rotary	CW	palm facing in (NOT up)
9	Head tilt right	cylinder	extended	head level (NOT tilted)
10	Right shoulder	cylinder	extended	arm down
11	Left wrist	cylinder	retracted	wrist straight (NOT bent)
12	Left elbow	cylinder	retracted	arm bent to chest
13	Left arm twist	rotary	CCW	palm facing in (NOT up)
14	Body turn right **	cylinder	extended	body turned left of center
15	Left shoulder	cylinder	extended	arm down
16	Head up (win)**	cylinder	extended	NOT looking up
17	Head turn (win)	cylinder	CCW	head turned left of center
18	Lip (win)	cylinder	extended	lip closed (up)
19	Mouth (win)	cylinder	retracted	mouth closed
20	Monitor	rotary	CCW	monitor facing audience

** rebuildable cylinders

(win) = window Looney head

DIAGRAM 2C

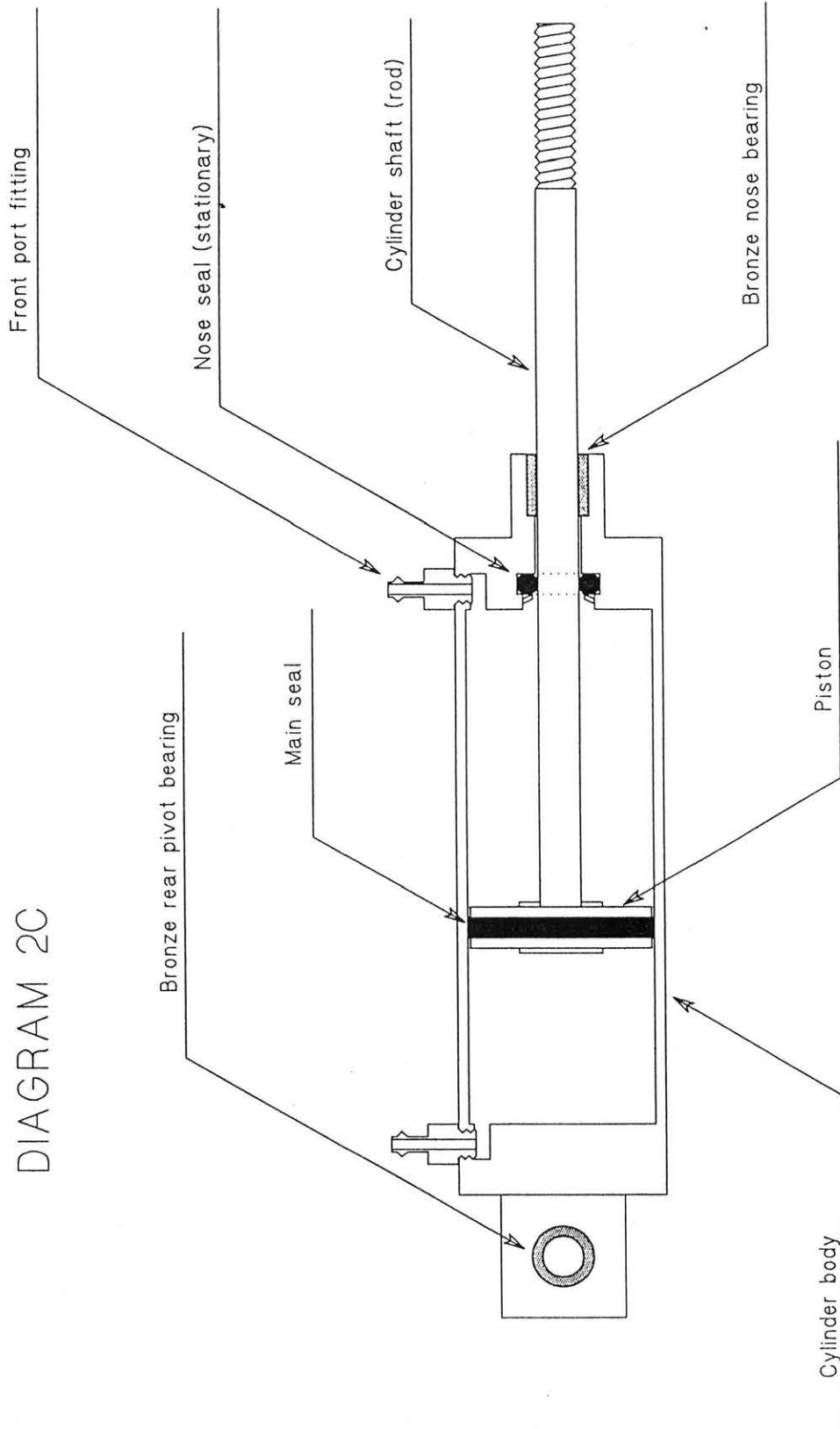

Cylinder bodies and shafts vary in size and shape, but all cylinders work essentially the same way.

Note: Rebuildable cylinders have removable rear caps. Maintenance-free cylinders do not.

Title:	Typical Cylinder (cross-section view)	Tolerance (unless indicated):	Creative Engineering, Inc. 47 West Jefferson Street Orlando, Florida 32801
Date:	06/30/95	Scale:	n/a

DIAGRAM 2D

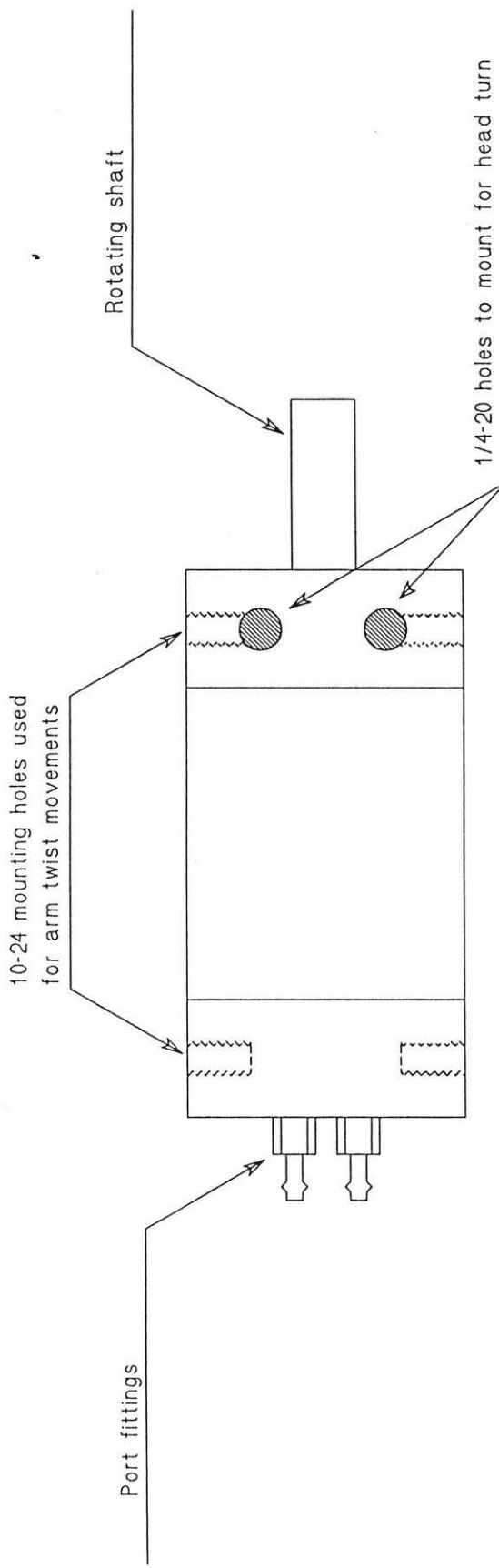

Rotary actuators are all the same size and shape; however, the three actuators used on each character are not interchangeable - the mounting holes and the number of degrees of rotation vary depending upon the character movement.

Title: Typical Rotary actuator		Tolerance (unless indicated):		Creative Engineering, Inc. 47 West Jefferson Street Orlando, Florida 32801	
Date: 06/30/95	Scale: Full				

DIAGRAM 2E

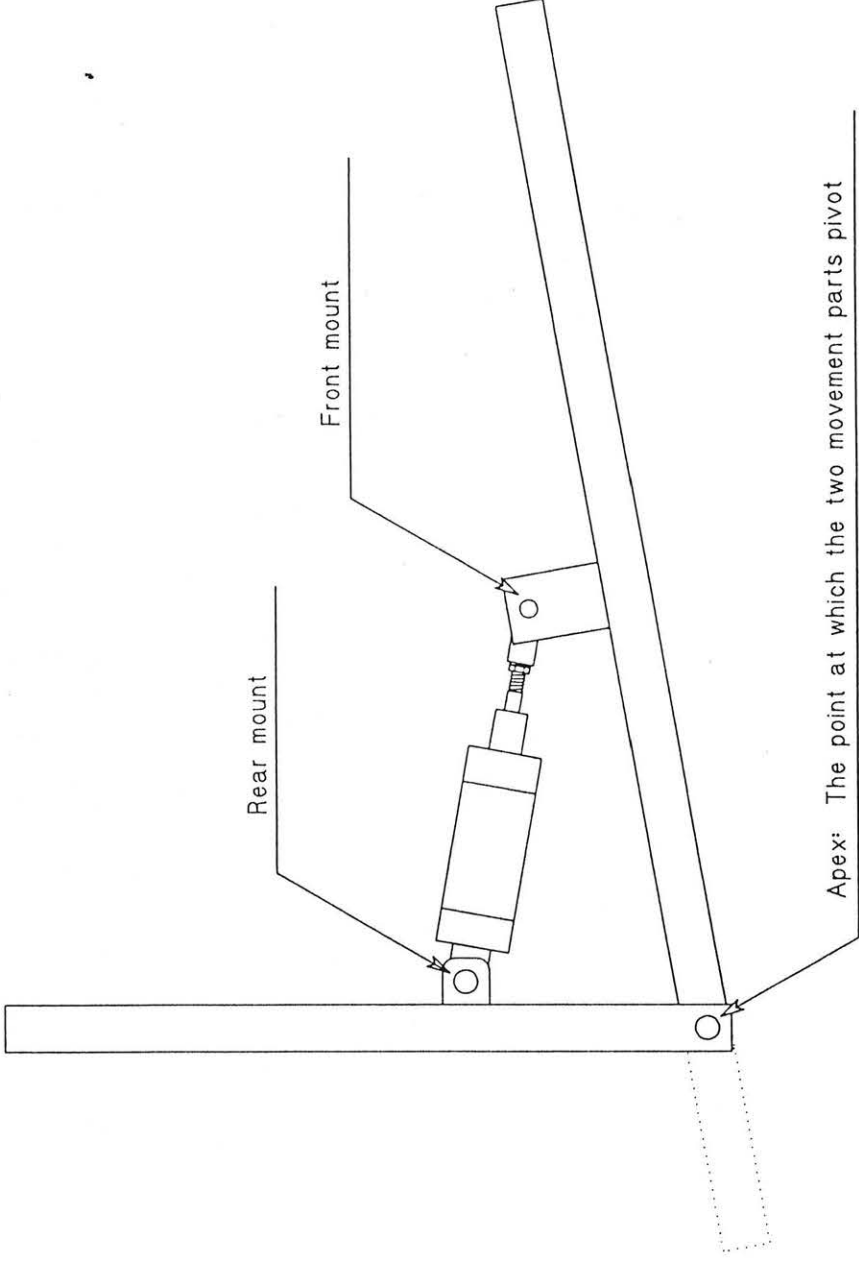

Title: Pivot Point example

Date: 06/14/95

Scale: n/a

Tolerance (unless indicated):

Creative Engineering, Inc.
47 West Jefferson Street
Orlando, Florida 32801

CHARACTER TURNTABLES

Each of the three center stage characters (Billy Bob, Mitzi, and Fatz) are attached to a small turntable, which allows each character to be independently positioned to face any direction at any time, regardless of the large turntable's position.

The character, the valve bank, and the bit-stripper are mounted in a wooden drum that is in turn mounted to a heavy-duty, hollow steel shaft. The shaft runs through an aluminum support mechanism called the "cradle," which is the three-inch square base with two vertical sides that attach it to the large turntable (see diagram 3B). Each character requires an air line to the valve bank, a power distribution cable to the bit-stripper, and a data cable to the bit-stripper. These three items come up through the hollow shaft into the drum, where they are held in place by strain-reliefs.

Under the cradle, on the lower end of the shaft, are two sprockets. The larger sprocket is attached by chain to the air motor that turns the character. The smaller sprocket is attached by chain in the other direction to a very large sprocket known as the "feedback gear." When the motor spins the turntable, the feedback gear is turned accordingly. The feedback gear has many sets of holes that, as it turns, pass between two circuit boards. Mounted on one board are infrared light emitters; mounted on the other board are infrared collectors. With everything properly aligned, the holes pass directly between the emitters and collectors. There are 15 unique combinations of holes that translate to 15 different turntable positions. Consequently, by monitoring the infrared boards, the computer knows where the turntable is and, when turning, which direction it is traveling, and when to stop.

These sprockets are preset at the factory and, aside from checking the chain tension (as described in the MAINTENANCE section), should never need adjustment. However, there are a number of areas of concern that should be fully understood by the store technician. The diagrams after this section will help clarify the following information regarding the character positions and the travel "limits" of the small turntables.

NOTE: With the exception of which direction each character faces relative to the large turntable, all three small turntables are mechanically identical by design and in operation.

CHARACTER POSITIONS:

The simplest way to understand the relationship of the small turntable positions is to put all three small tables AND the large table in their center positions. To do this, choose a time when the store is closed and then continue by doing the following: Choose SHOW ADJUSTMENT UTILITIES from the Main Menu, then choose POSITION CHARACTERS IN FRONT. Press number 4 which is FATZ AND MITZI FRONT. As shown in diagram 3A, this will position Fatz and Mitzi toward the front of the stage, and Billy Bob at the rear of the stage, directly in front of the big white circle on the back wall. At the same time, the small turntables have been positioned so that all three characters are facing directly forward. All four tables are now in their "center" positions. The center position for a small table is exactly half way between the fully clockwise extreme of the table and the fully counterclockwise extreme. (The center position of the large turntable is Billy Bob to the back of the stage, roughly centered between left and right.) A small turntable, from extreme counterclockwise to extreme clockwise, rotates slightly more than one and one-half revolutions (about 550 degrees). Consequently, when a small table is at its center position, the table can be turned three-quarters of a revolution in either direction before hitting a mechanical stop mechanism that prevents the table from going any farther. (For more information on positions, see the SHOW ADJUSTMENT UTILITIES section.)

Whenever the computer sends a small turntable to a new position, it knows that there will be a small amount of drift (coasting) after the air motor is shut off; consequently, the motor is shut off a fraction of a second early to allow the turntable to coast to a stop, at or very near the desired position. As you can imagine, if the turntable speed (as defined in the MAINTENANCE section) is too fast, it will coast much too far and go beyond the target position; too slow, and the table won't even reach the target position. It's your responsibility, as with the large turntable, to check the small turntable speeds regularly.

THE LIMITS - SMALL TURNTABLE STOP MECHANISM:

ABOUT THE STOP MECHANISM - As mentioned above, each small turntable has a mechanical stop mechanism that prevents the table from turning too far in either direction. Mounted on the side of the cradle above the feedback gear is an "L" shaped aluminum bracket (see diagram 3B). Bolted to the bracket is a heavy-duty steel pin that extends straight down next to the hub of the feedback gear. On the hub of the feedback gear itself, there is a bolt (with an aluminum spacer and lock washer) tightly screwed into and extending from the hub. When a character is turned to either extreme position, the bolt contacts the steel pin, which stops the table from turning any farther. The bolt and pin are very strong but NOT unbreakable. If the turntable is traveling too fast, it will coast considerably more than it should and will

result in the bolt hitting the pin with enough force to break the bolt, the pin, or both. Keeping the small turntables properly adjusted will prevent any breakage.

BROKEN STOP - If any part of the stop mechanism is broken, you should stop the show as soon as possible to avoid any further damage, and administer repairs. Before doing repairs, you will have to determine if the character is still in sync ("sync" is short for synchronization), and determine what caused the table to hit the stop so hard. But first, a little about "sync."

ABOUT SYNCHRONIZATION (SYNC):

There is a direct relationship between the small turntable and the feedback gear. The exact position of the turntable is determined by the exact position of the feedback gear. When the turntable and the feedback gear are in perfect sync, the position information sent to the Big Important Board is correct. As a result, when the Big Important Board "thinks" the table is at (for instance) its center position, the table actually IS at its center position. If, however, the table and feedback gear get OUT of sync, the feedback gear will continue to send position information to the Big Important Board, but the actual position of the table will be altogether different and unpredictable.

HOW DOES IT HAPPEN?:

There is only ONE way for a character turntable to get out of sync. The table must travel too far in either direction (go past the extreme clockwise or extreme counterclockwise position), which can only occur if the stop-bolt or stop-pin is broken. This can happen if the turntable speed is too fast and slams into the stop, or if a person manually spins the turntable (too fast/too hard) until it hits the stop, causing breakage. Regardless of how it happens, if the table spins PAST the normal stop point (in either direction), the circuit boards that straddle the feedback gear will begin reading holes that don't correctly correspond to the character's position. At this point, if a show is run, the turntable will likely turn, BUT the table and the feedback gear are no longer in sync.

To go into greater detail, the gear on the hollow steel shaft and the feedback gear have different numbers of teeth. The feedback gear is larger (60 teeth) than the hollow-shaft gear (36 teeth). Consequently, the two gears do not have a 1-to-1 ratio. The actual ratio is 5-to-3 to allow the turntable to travel about 190 degrees MORE than one complete revolution while the feedback gear makes LESS than one revolution.

If the small turntable goes past a normal stop point, the table and gear will be OUT of sync by 72 degrees or more. So, the characters will always be facing the wrong direction. EVEN WORSE, the two wires that go up through the hollow shaft to the bit-stripper board will get twisted far beyond normal and could break. If the table is out of sync, stop the show immediately and do the following:

Step 1) SAFETY FIRST:

Disconnect the air line that feeds the large turntable air motor. Disconnect the air line that feeds the character air motors. You will need to get under the large turntable for inspection and repairs, and certain corrective measures might cause the tables to move suddenly if air pressure is still applied to the air motors.

Step 2) MOVING THE LARGE TURNTABLE:

Manually position the large table so that the character that needs work is next to a spot where you can get under the stage.

CAUTION: Be absolutely certain that you are turning the large turntable the right direction. You must not allow the table to contact the limit switch. If you are unfamiliar with the large turntable operation and its "limit" switch, read the LARGE TURNTABLE section before going any farther.

Step 3) INSPECTION:

Look carefully at the wires that go up through the hollow shaft. These wires are secured to the end of the cradle and are originally set to have a lot of slack (droop) between the end of the cradle and the hollow shaft (basically along side the air line). If the wires appear to be excessively twisted (compared to the other characters), make a note of which direction they are twisted, as you will NOT want to spin the character any further in that direction.

Step 4) VERIFYING THE SYNC:

Your small turntables should have center marks (as described in the Turntable Positioning Exercise of the SHOW ADJUSTMENT UTILITIES section). The goal is to align the small turntable center mark with the mark on the large turntable, then check to see if the feedback gear is reading "center" as well. Simply rotate the small table one way or the other (watch the wires) until the center marks align. Next, select SHOW ADJUSTMENT UTILITIES from the Main Menu, then choose READ TURNTABLE L.E.D'S. On the next screen, locate the name of the character you are

working on and note the number next to it. The range of possible numbers is 0 to 15. Numbers 0 through 14 (on the computer screen) correspond to the 15 readable turntable positions. Number 15 (on the screen) indicates that the infrared readers are between holes. The center position of a character is 7. If your character's center marks are aligned and the readout is 7, the turntable is in sync - skip down to Step 5. If the readout is not 7, read OUT OF SYNC below.

OUT OF SYNC - If the center marks are aligned and the readout is not 7, you must rotate the table one complete turn until the center marks align once again. The only criteria for determining which direction to turn the table is the amount of twist in the wires. Choose the direction that is more friendly to the wires, then go ahead with rotating the table one complete revolution.

Note: While you are turning the table, have someone watch the readout to make sure the numbers are changing as the table spins. This ensures that the signals from the infrared boards are reaching the Big Important Board. If the numbers don't change while the table is moving, go to the NO DATA TO / FROM TURNTABLES section now.

After rotating the table one turn and aligning the center marks again, check the readout for 7. If the readout is 7, skip down to Step 5. If the readout is not 7, you will need to repeat this process of turning the table one complete revolution at a time (in the SAME direction) until the readout is 7. In any event, the maximum number of revolutions to put the table back in perfect sync is four revolutions. When the center marks are aligned and the readout is 7, go to Step 5.

Step 5) BACK IN SYNC:

Now that the turntable is back in sync, you need to repair the stop mechanism before the table is turned any more. If the stop-pin broke, simply mark where the old pin is tightened in the bracket's slot, and replace it with the new pin. If the stop-bolt broke, locate the stop-bolt hole (which is now at its farthest point away from the pin, meaning, it is on the other side of the cradle from the stop-pin). Remember, the hole you are looking for is 180 degrees away from the stop-pin, NOT the hole that is roughly 90 degrees away. When you've located the hole, you will need to remove the broken-off end of the bolt still in the hole, using either needle-nose pliers or, if necessary, an Easy Out tool. Replace the bolt/washer/spacer combination EXACTLY as it originally was, using a 5/16-24 x 3/4 inch socket head cap screw, a "high collar" lock washer, and the 1/4 inch aluminum spacer. When properly replaced, the end of the bolt should contact the pin, but NOT hit the upper infrared board as it passes by.

Step 6) FINAL CHECK:

If you haven't already done so, read the SHOW ADJUSTMENT UTILITIES section in order to fully understand references to numbered positions of the small turntable.

- A) Align the center marks one more time and check the readout for number 7.
- B) Rotate the table clockwise to the position 14 mark, then continue turning slowly and note how far past the mark the table goes before stopping.
- C) Rotate the table fully counterclockwise to the position 0 mark, then continue turning slowly and note how far past the mark the table goes before stopping.
- D) The amount of travel between the mark and the stop is the "end zone." Both end zones should be the same distance, give-or-take a half inch. If one end zone is longer than the other, you will need to adjust the stop-pin by loosening it, sliding it in the adjustment slot of the bracket, and retightening the pin. (You'll probably need to hold the pin with a pair of ViseGrips to keep it from turning.)
- E) When the end zones are equal, the table is ready.

Step 7) PUTTING THINGS BACK:

Reconnect the air line to the large turntable air motor and the air line to the character air motors. Go back to the menu on the computer, choose POSITION CHARACTERS IN FRONT, and press number 4 which is FATZ AND MITZI FRONT. Compare to diagram 3A.

Step 8) RUNNING THE SHOW:

Follow the normal procedures for starting up the system, and run a show.

DIAGRAM 3A

Large turntable CENTER position

Billy Bob is REAR and center.

All characters facing forward

Note: This position is # 16

● = Front-and-center point of turntable

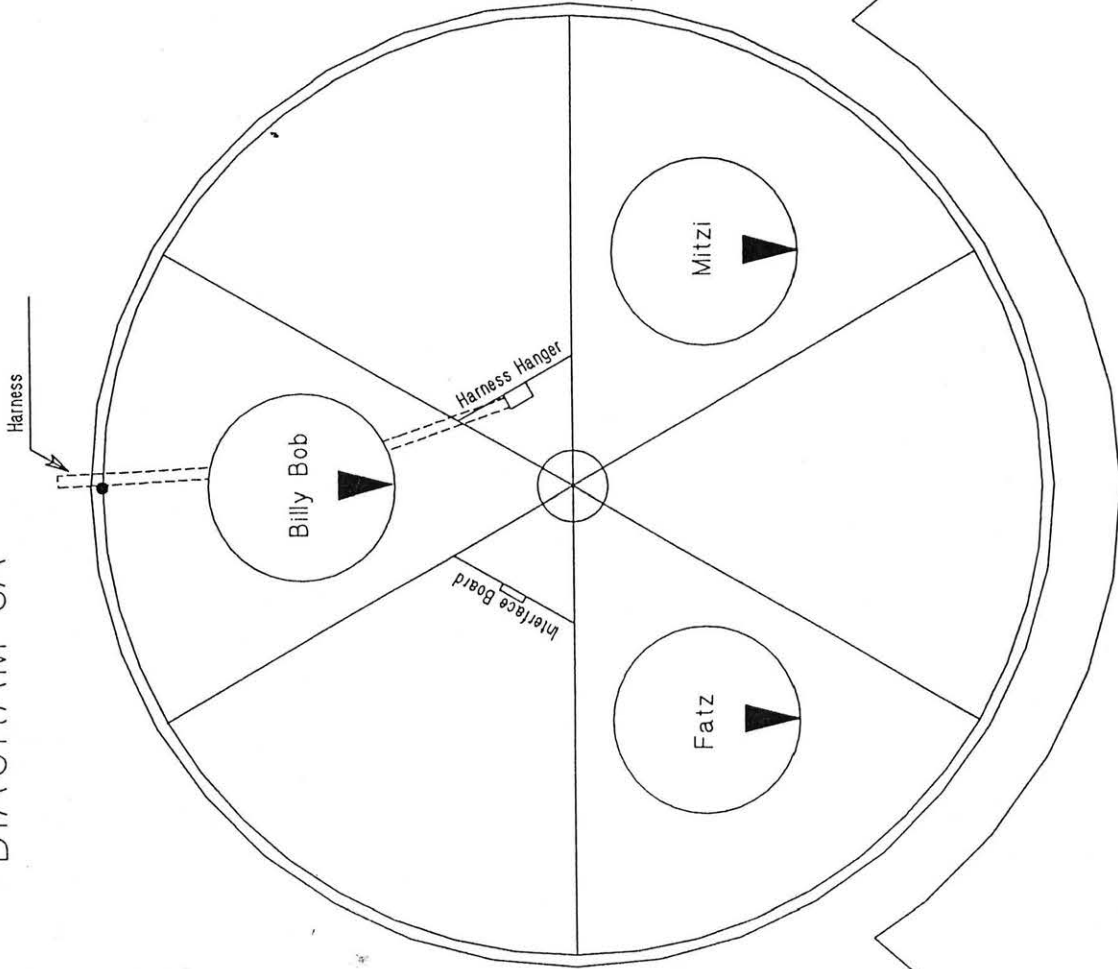

Title: Fatz and Mitzi front (Utilities: Position Characters)

Date: 08/15/95

Scale: Representational

Tolerance (unless indicated):

Creative Engineering, Inc.
47 West Jefferson Street
Orlando, Florida 32801

DIAGRAM 3B

NOTE: For clarity purposes, the chains, wires, and hoses are not shown in this drawing.

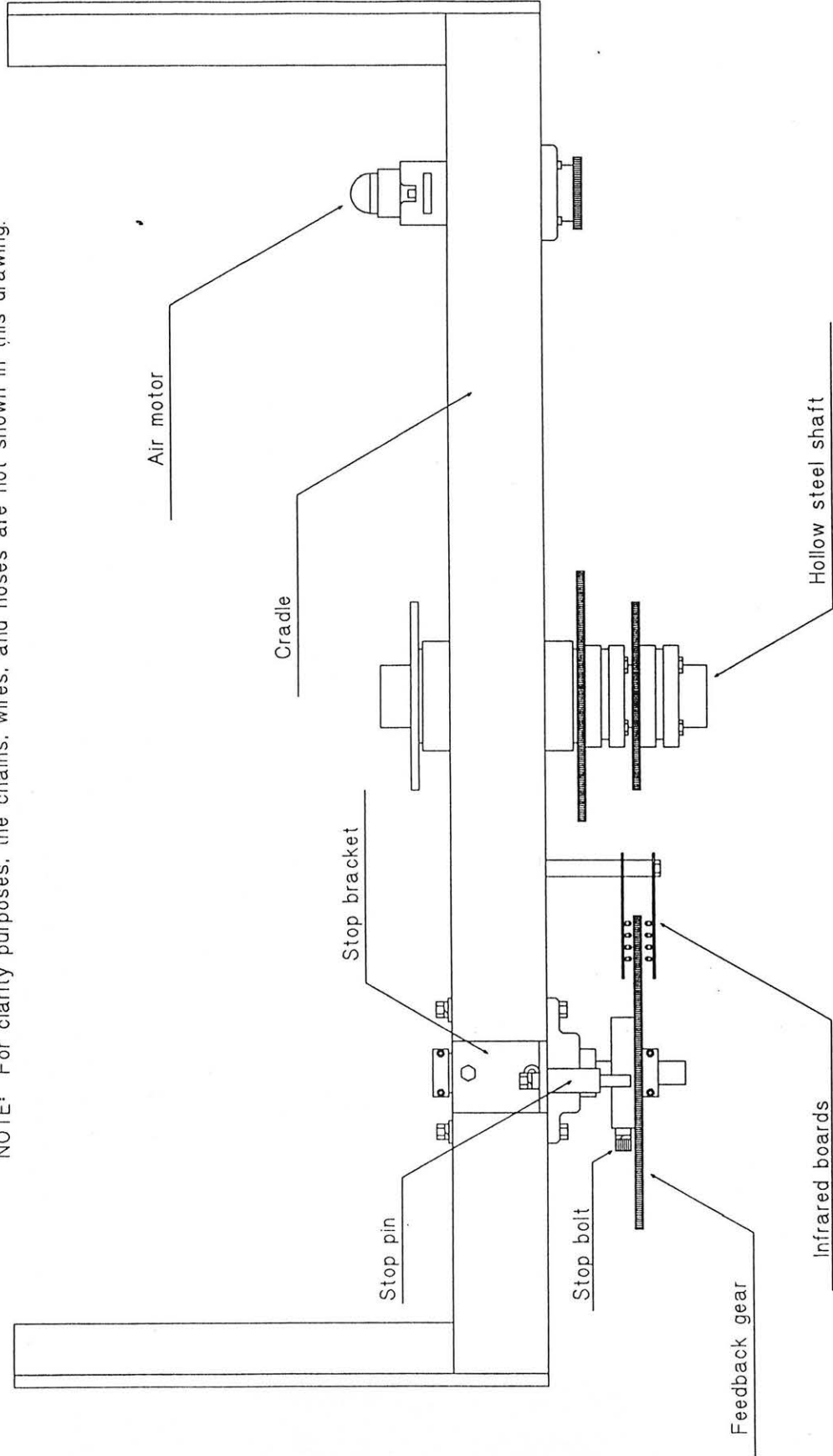

Title: Cradle

Date: 05/08/95

Tolerance (unless indicated):

Scale: 1/5 (approximate)

Creative Engineering, Inc.
 47 West Jefferson Street
 Orlando, Florida 32801

LARGE TURNTABLE

The large turntable (center stage) functions similarly to the character turntables, yet on a much larger scale. The turntable carries the three center stage characters - Billy Bob, Fatz, and Mitzi. Suspended beneath the turntable midway between Billy Bob and Mitzi is the main harness that provides air and electrical power to the turning table. This harness is shown in dashed lines in the diagrams that follow this section.

The table is turned by a large air motor located on the back of the stage. Mounted to the air motor shaft is a drive wheel and tire that runs on diamond plate attached to the perimeter of the turntable. To keep the tire from slipping on the diamond plate, there is an air cylinder that presses the motor/tire assembly against the diamond plate. There is a small, adjustable pressure regulator with a gauge attached to the cylinder itself. The pressure gauge should read 40 to 50 p.s.i. when the show is running.

Under the center of the turntable is the steel pedestal that supports much of the table's weight and houses the main shaft and bearings on which the table spins (see diagram 4F). On the pedestal is a small sprocket. Mounted on one of the spokes of the turntable is a shaft with a larger sprocket known as the feedback gear. The two sprockets are attached by chain. When the turntable spins, the feedback gear is turned accordingly. The feedback gear has many sets of holes that, as it turns, pass between two circuit boards. Mounted on one board are infrared light emitters; mounted on the other board are infrared collectors. With everything properly aligned, the holes pass directly between the emitters and collectors. There are 31 unique combinations of holes that translate to 31 different turntable positions. Consequently, by monitoring the infrared boards, the computer knows where the turntable is and, when turning, which direction it is traveling, and when to stop.

These sprockets are preset at the factory and should never need adjustment; however, there are a couple areas of concern that should be fully understood by the store technician. The diagrams after this section will help clarify the following information regarding the travel "limits" of the large turntable.

As shown in diagram 4A, when the computer sends the table fully clockwise, Billy Bob is front-and-center. As shown in diagram 4B, when the table is sent fully counterclockwise, Billy Bob travels beyond the front-and-center position and ends up closer to the big screen TV. During a show, whenever the computer sends the table to a new position, it knows that there will be a certain amount of drift (coasting) after the air motor is shut off; consequently, the motor is shut off a fraction of a second

early to allow the turntable to coast to a stop, at or very near the desired position. As you can imagine, if the turntable speed (as defined in the MAINTENANCE section) is too fast, it will coast much too far and go beyond the target position; too slow, and the table won't even reach the target position. It's your responsibility, as with the character turntables, to check the large turntable speed regularly.

IMPORTANT: The large turntable DOES NOT have a mechanical stop mechanism to prevent the table from going beyond the extreme clockwise position or extreme counterclockwise position. Instead the table is equipped with a limit switch that, when triggered, immediately shuts off all air to the large turntable motor and temporarily "kills" the large table, meaning it will no longer move at all on its own (see diagram 4F). This limit switch is mounted on the aluminum stage spoke next to the feedback gear shaft. There is a pin extending from the feedback gear shaft that comes in contact with the limit switch if the table travels too far in either direction. IF the table is traveling too fast and/or, for any other reason, the table travels too far in either direction, the limit switch will be triggered and the air motor shut down. In such event, it is critically important that the following procedures be used to correct the situation:

Step 1) QUALIFIED PEOPLE ONLY:

DO NOT allow any unqualified person to touch the turntable, e.g., a customer or employee that thinks giving the stage a "push" will fix the problem. In all likelihood, the problem will be compounded instead of cured. Please make sure that there is a "hands off" policy in place for this unlikely event.

Step 2) SAFETY FIRST:

Turn off the computer. This will prevent shows from running while you are seeing to the needs of the large turntable.

CAUTION: Do not get under the stage during any procedure in this section.

Step 3) DETERMINING THE DIRECTION OF TRAVEL:

YOU MUST determine which direction the table was traveling when the limit switch was impacted. This is done by noting two factors. First, where is Billy Bob located and, second, which way is the main harness wrapped around the pedestal? These can be easily determined by comparing your stage to the diagrams 4C and 4D. Diagram 4C shows the approximate positions of Billy Bob and the harness if the table traveled too far clockwise. Diagram 4D shows the approximate positions when the table travels too far counterclockwise. DO NOT rely on Billy Bob's position alone.

ALWAYS check the position of the main harness too, as it will ALWAYS TELL THE TRUTH. (NOTE: If the positions of your Billy Bob and the main harness DON'T resemble one of the two diagrams (4C and 4D), proceed directly to the next section entitled "LARGE TURNTABLE SYNC PROBLEM ?").

Step 4) MOVING TURNTABLE AWAY FROM LIMIT SWITCH:

TOO FAR CLOCKWISE - If the turntable has gone too far clockwise, push the turntable counterclockwise until Billy Bob is front-and-center and the harness is lying as shown in diagram 4A. This puts the table into the normal operating area and moves the pin off of the limit switch, returning air pressure to the motor. Read the CAUTION's below and go on to Step 5.

TOO FAR COUNTERCLOCKWISE - If the turntable has gone too far counterclockwise, push the turntable clockwise until Billy Bob is front-and-center and the harness is lying as shown in diagram 4E. This puts the table into the normal operating area and resets the limit switch, returning air pressure to the motor. Read the CAUTION's below and go on to Step 5.

CAUTION: DO NOT run a show after manually pushing the large turntable without first completing this section.

CAUTION: Be extremely careful not to push the table the wrong way. If the stage is manually pushed too far in the WRONG direction in error, the pin that contacts the limit switch will eventually go completely PAST the limit switch, allowing the switch to reset which restores air pressure to the motor. If this happens, the relationship between the turntable and the feedback gear (which tells the computer where the table is) is now completely out of sync. ("sync" is short for synchronization.) When the show runs, the large table will likely turn, BUT the characters will always be facing in a direction they shouldn't be. Another problem, even more important, is that the main harness can get wrapped MORE than once around the pedestal - a situation that can cause SEVERE damage to the harness and turntable (see LARGE TURNTABLE SYNC PROBLEM ?).

Step 5) PRESSING THE RESET BUTTON:

When the RESET button is pressed, the Big Important Board instructs the large turntable to turn counterclockwise until it finds the first set of readable holes on the feedback gear (the character turntables will be resetting at the same time). Under normal circumstances, the table will only have to move less than 10 inches before finding the next set of holes, taking less than 1 second of time. The turntable will stop turning, the system will be properly "reset," and you're ready for Step 6.

NOTE 1 - However, if the turntable travels more than about 3 feet counterclockwise without the infrared boards detecting a set of holes, which is unusual, the table will reverse and begin turning clockwise BACK toward the original position, searching the area again for a set of holes. If the search is successful, the table will stop before even getting back to the original position. When the holes are located, the table will stop turning, the system will be properly "reset," and you're ready for Step 6.

NOTE 2 - Though very unlikely, IF the turntable searches counterclockwise and then resorts to clockwise (as described above) and STILL fails to read a set of holes, the table will stop near too, or even PAST, the original position, which is much too far to travel without finding any holes, and indicates a problem. The turntable will stop turning altogether and the Big Important Board will go into a 20-40 second time-out. At the end of the 20-40 seconds, the Big Important Board will try again. It will automatically start the entire search process over, the equivalent of pressing the RESET button again.

Step 6) IS THE TURNTABLE RESET OR IS IT WAITING TO TRY AGAIN?

After the turntable stops moving, simply wait to see if the Big Important Board starts to search again within 40 seconds. If the table does NOT start moving again, skip down to CHECKING RESULTS. If the table DOES start moving again, read SEARCHING AGAIN below.

SEARCHING AGAIN - If the table begins moving again, wait for it to complete its 2nd attempt to find readable holes and comes to a complete stop. Again, WAIT 40 seconds to see if it starts a 3rd search. If the table does NOT start moving again, skip down to CHECKING RESULTS. If it starts a THIRD search, there is something wrong and you will need to intervene to stop the process. To avoid getting stuck in this "loop," shut down the ENTIRE system. As long as Billy Bob was properly positioned front-and-center prior to pressing the RESET button, there is only one logical explanation for endless searching - the signals from the infrared boards are not reaching the Big Important Board. Go to the NO DATA TO / FROM TURNTABLES section.

CHECKING RESULTS - If 40 seconds passes without the table moving again by itself, it is probably reset. PLEASE, don't run a show just yet. First, check the turntable positions by doing the following: Turn on the computer (it should have been off). Go to the Main Menu and select SHOW ADJUSTMENT UTILITIES. Then choose ADJUST TURNTABLES. Select BIG TABLE CENTER. This should send Billy Bob to the back of the stage, roughly in the center (pay no attention to which direction Billy Bob is actually facing). Next, select BIG TABLE CW. This should turn the large turntable clockwise and send Billy Bob to the front-and-center position, give or take a few inches.

If Billy Bob ends up in the correct position both times, go on to Step 7. If Billy Bob does NOT end up in the correct position both times, go directly to the LARGE TURNTABLE SYNC PROBLEM ? section.

Step 7) RUNNING THE SHOW AFTER A "RESET"

Follow the normal procedures for starting up the system, and run a show. When the show is running, note the positions of the characters. If they are not where they should be and are facing the wrong direction, the large turntable is out of sync. See LARGE TURNTABLE SYNC PROBLEM ? section.

DIAGRAM 4A

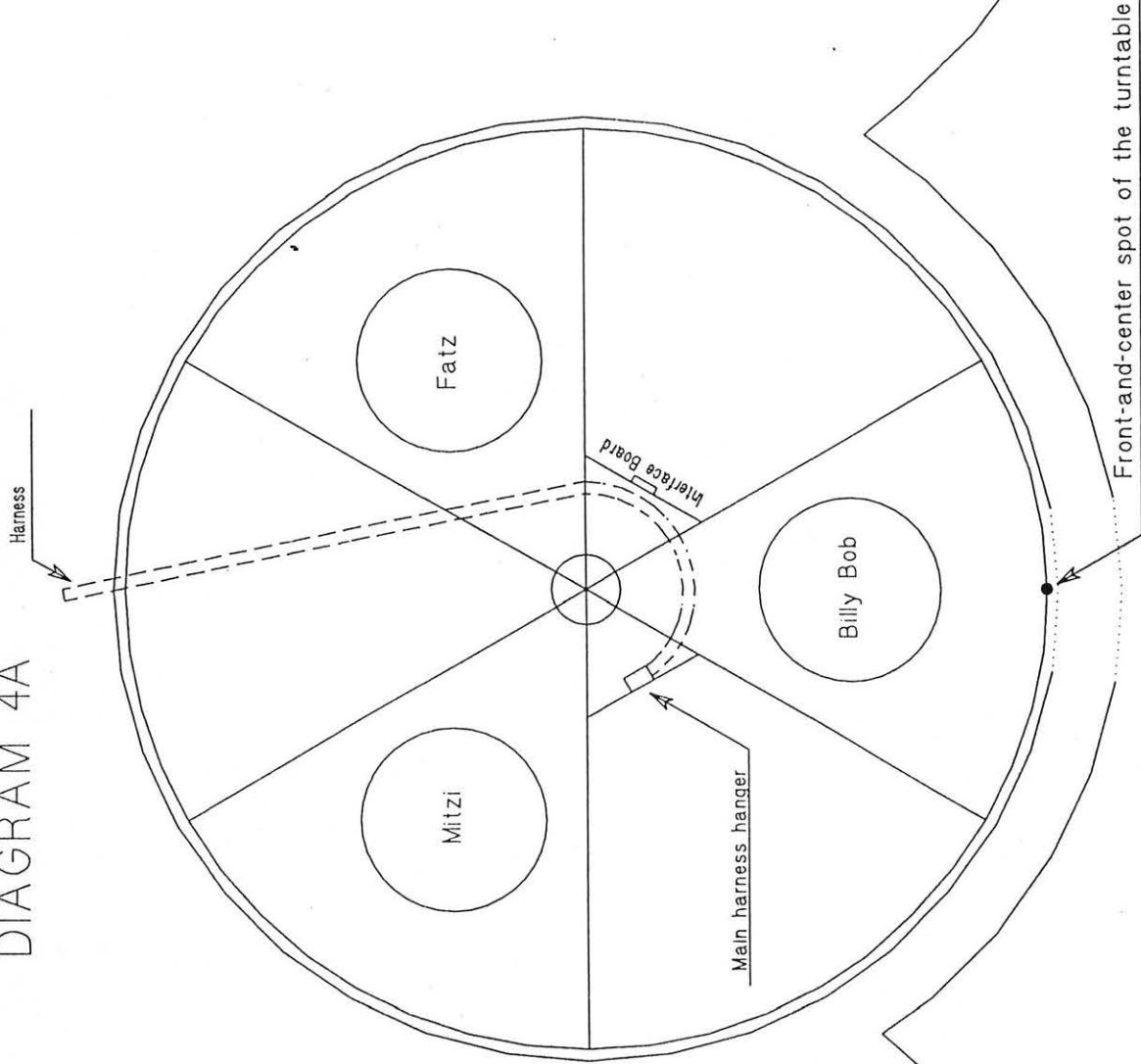

Billy Bob is front and center.

Main harness is PARTIALLY around the pedestal as shown.

Note: This position is referenced for RESET purposes in some sections of the manual.

● = Front-and-center point of turntable

Title: Fully clockwise position (#30 front-and-center)

Date: 08/15/95 Scale: Representational

Tolerance (unless indicated):

Creative Engineering, Inc.
47 West Jefferson Street
Orlando, Florida 32801

DIAGRAM 4C

Turntable is beyond the normal extreme clockwise position.

Main harness is PARTIALLY around the pedestal as shown.

● = Front-and-center point of turntable

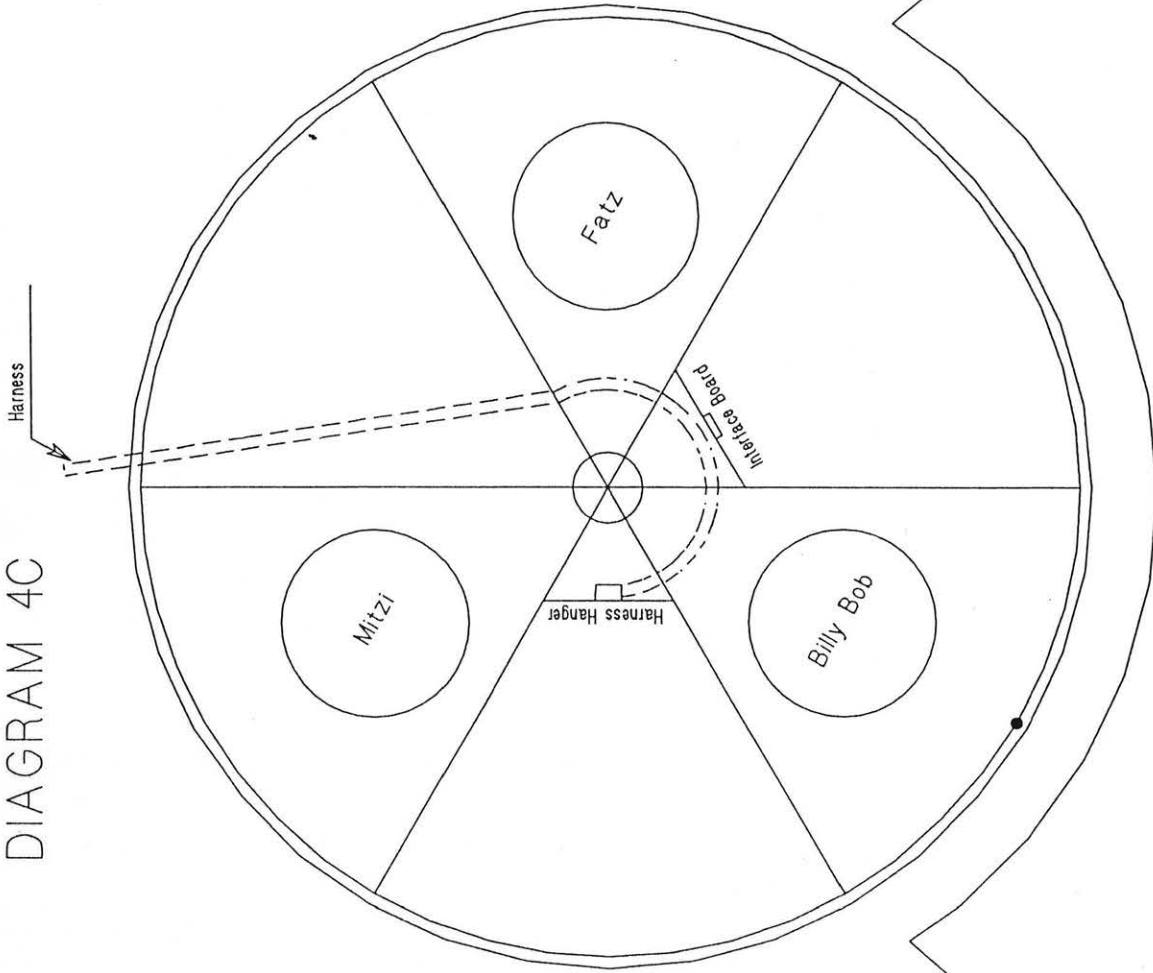

Title: Beyond fully clockwise position, limit switch triggered

Date: 08/15/95 Scale: Representational

Tolerance (unless indicated):

Creative Engineering, Inc.
47 West Jefferson Street
Orlando, Florida 32801

DIAGRAM 4D

Turntable is beyond the normal extreme counterclockwise position.

Main harness is PARTIALLY around the pedestal as shown.

● = Front-and-center point of turntable

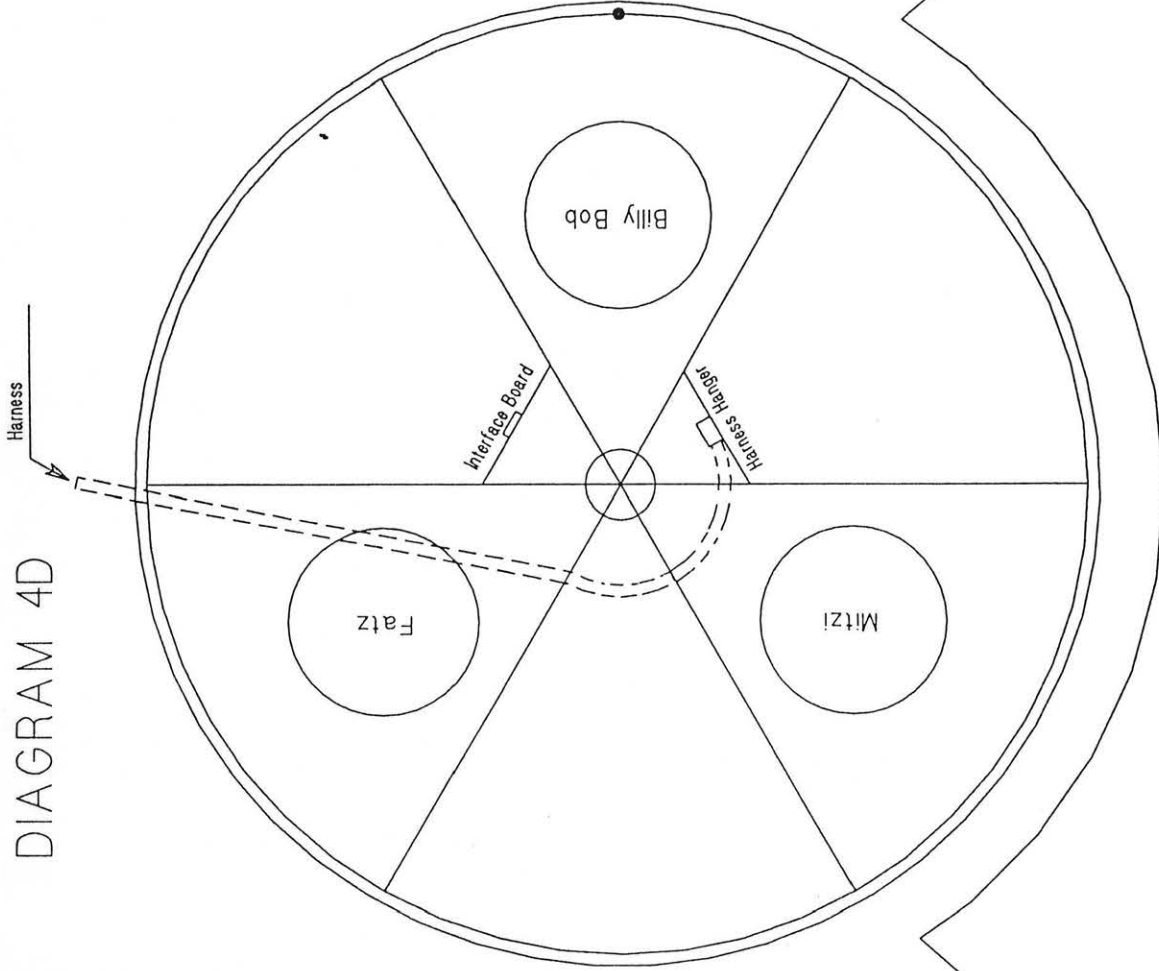

Title: Beyond fully counterclockwise position, limit switch triggered

Date: 08/15/95

Scale: Representational

Tolerance (unless indicated):

Creative Engineering, Inc.
47 West Jefferson Street
Orlando, Florida 32801

DIAGRAM 4E

Billy Bob is front and center.
 (Don't confuse with diagram 4A)
 Main harness is BARELY around
 the pedestal as shown.

Note: This position is referenced
 for RESET purposes in some sections
 of the manual.

● = Front-and-center point of turntable

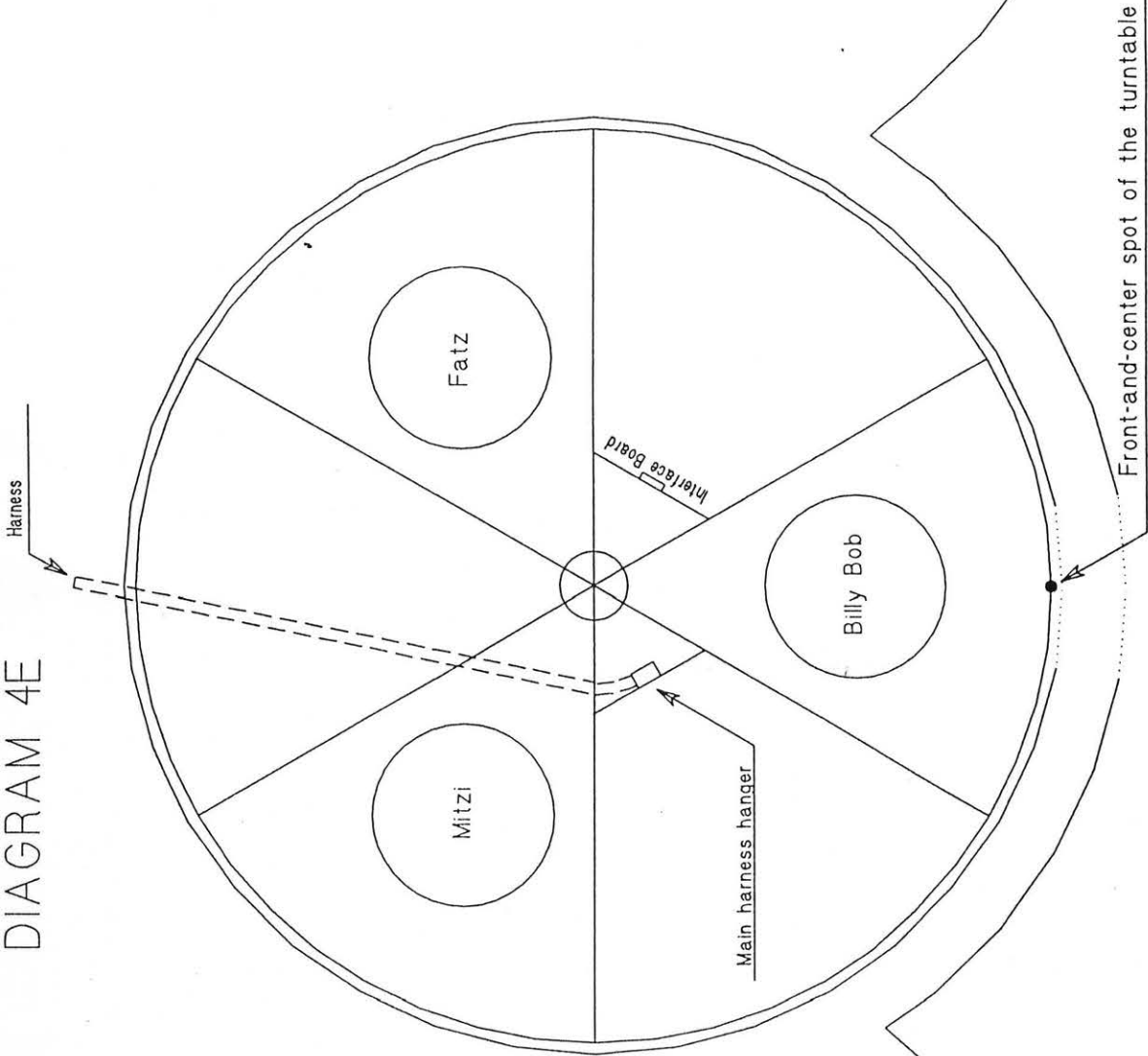

Title: #1 front-and-center

Date: 08/15/95

Scale: Representational

Tolerance (unless indicated):

Creative Engineering, Inc.
 47 West Jefferson Street
 Orlando, Florida 32801

DIAGRAM 4F

NOTE 1: For clarity purposes, the chain and chain tensioner are not shown in this drawing.

NOTE 2: The chain tensioner (not shown) is a spring-loaded idler sprocket that prevents chain derailment. The tensioner must be in place at all times.

Pin that contacts safety switch trigger

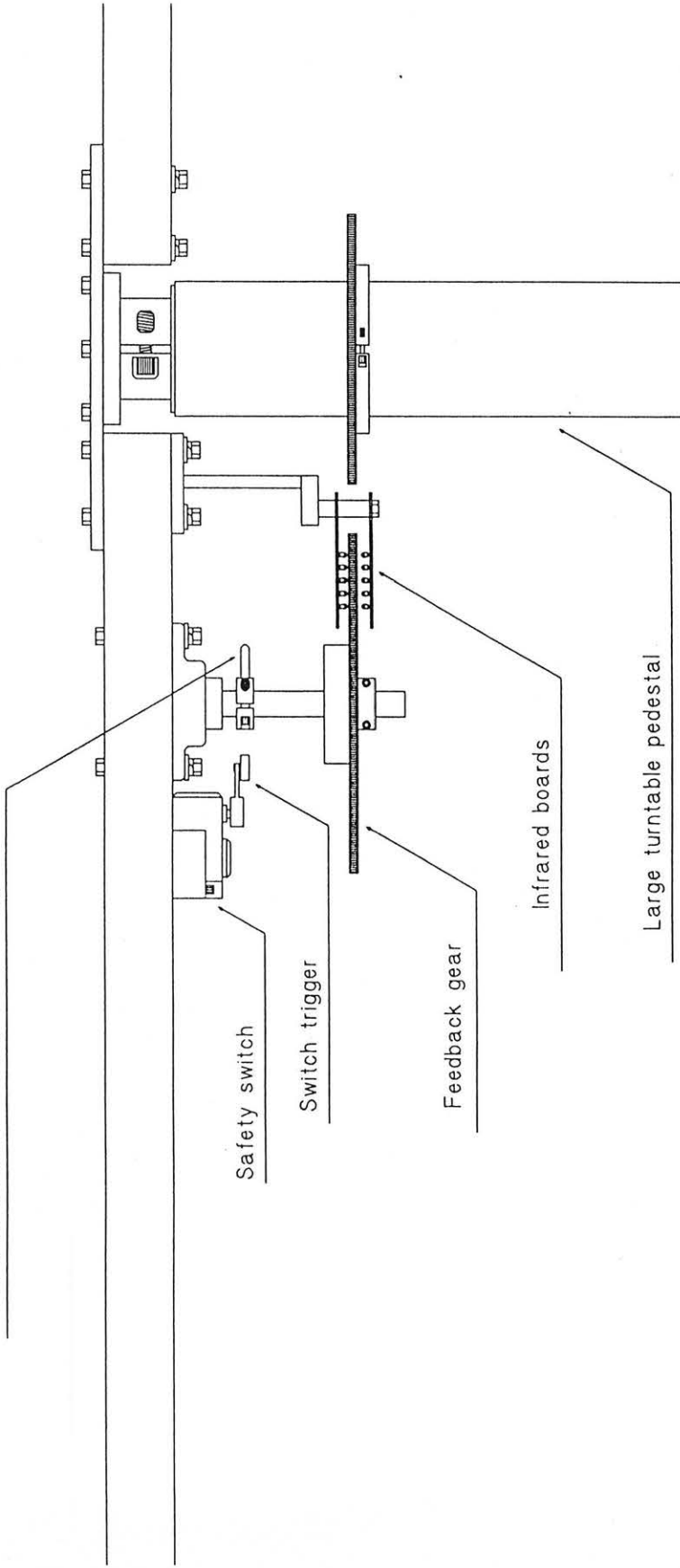

Title: Large turntable feedback assembly

Date: 06/15/95

Scale: 1/5 (approximate)

Tolerance (unless indicated):

Creative Engineering, Inc.
47 West Jefferson Street
Orlando, Florida 32801

LARGE TURNTABLE SYNC PROBLEM ?

As noted in the last section, there is a direct relationship between the large turntable and the feedback gear. The exact position of the turntable is determined by the exact position of the feedback gear. When the turntable and the feedback gear are in perfect sync, the position information sent to the Big Important Board is correct. As a result, when the Big Important Board "thinks" the table is at position 12, the table actually IS at position 12. If, however, the table and feedback gear get OUT of sync, the feedback gear will continue to send position information to the Big Important Board, but the ACTUAL position of the table will be altogether different and unpredictable.

HOW DOES IT HAPPEN?:

There is only ONE way for the large table to get out of sync. First, the table must travel too far in either direction (go past the extreme clockwise or extreme counterclockwise position), triggering the limit switch. This can happen if the turntable speed is too fast and drifts into the switch, or if a person pushes the table until it hits the switch. In either case, the limit switch turns off air pressure to the turntable motor. Second, a person must manually push the table farther in the wrong direction (farther past the extreme position), causing the pin that contacts the limit switch to go completely PAST the switch, allowing the switch to reset, returning air to the motor. At this point, if a show is run, the turntable will likely turn, BUT the table and the feedback gear are no longer in sync.

To go into greater detail, the pedestal gear and the feedback gear have different numbers of teeth. The feedback gear is larger (60 teeth) than the pedestal gear (48 teeth). Consequently, the two gears do not have a 1-to-1 ratio. The actual ratio is 5-to-4 to allow the turntable to travel about 50 degrees MORE than one complete revolution while the feedback gear makes LESS than one revolution.

If the table is manually pushed far enough to go all the way PAST the limit switch, the table and gear will be OUT of sync by as much as 180 degrees. So, the characters will always be in the wrong positions and will always be facing the wrong way. EVEN WORSE, the main harness will get wrapped as much as TWICE around the pedestal. Even with slack in the harness, this situation can and PROBABLY WILL CAUSE DAMAGE to the turntable and/or harness. If the table is out of sync, stop the show immediately and do the following:

PUTTING THE TURNTABLE BACK IN SYNC:

Step 1) SAFETY FIRST:

Disconnect the air line that feeds the large turntable air motor. If you have not already turned off the computer, turn it off now. You may need to get under the large turntable for inspection, and certain corrective measures might cause the table to move suddenly if air pressure is still applied to the air motor.

Step 2) INSPECTION

Refer to diagrams 4A and 4B again. Keep in mind that these two diagrams clearly show the absolute most that the harness should be around the pedestal in either extreme position. In both diagrams, note that the harness is not actually "wrapped" around the pedestal at all. In diagram 4B, the harness hanger (the aluminum channel that pulls the harness around) doesn't even go beyond the front of the pedestal. In 4A, the harness hanger goes just barely past the front of the pedestal.

Look under the turntable from behind the stage, remove any extra slack in the harness, and carefully note the lay of your harness in relation to the pedestal. If the harness is wrapped too much in one direction, the stage will need to be manually pushed (rotated) in the opposite direction as described below.

Step 3) MOVING THE TABLE:

WRAPPED TOO MUCH CLOCKWISE - If the harness is wrapped around the pedestal too much in the clockwise direction, then have someone push the turntable counterclockwise until Billy Bob is front-and-center (if, while pushing, the pin contacts the limit switch, keep pushing right on past it). The relationship between your harness and the pedestal should now resemble diagram 4A. If they do, skip down to Step 4. If your harness is NOT currently lying the same as pictured in the diagram, then your stage must have been MORE than one full revolution out of sync, and you will have to determine which way the turntable needs to be turned to get your table and harness to the positions in diagram 4A. (If your table was this far out of sync, take the time to carefully inspect the harness and where it connects to the hanger for damage.) When the table and harness are correctly set (diagram 4A), skip down to STEP 4.

WRAPPED TOO MUCH COUNTERCLOCKWISE - If the harness is wrapped around the pedestal too much in the counterclockwise direction, then have someone push the turntable clockwise until Billy Bob is front-and-center (if, while pushing, the pin contacts the limit switch, keep pushing right on past it). The relationship between your harness and the pedestal should now resemble diagram 4E.

If they do, skip down to Step 4. If your harness is NOT currently lying the same as pictured in the diagram, then your stage must have been MORE than one full revolution out of sync, and you will have to determine which way the turntable needs to be turned to get your table and harness to the positions in diagram 4E. (If your table was this far out of sync, take the time to carefully inspect the harness and where it connects to the hanger for damage.) When the table and harness are correctly set as (diagram 4E), go on to Step 4.

Step 4) PUTTING THINGS BACK:

Reconnect the air line to the air motor.

Step 5) PRESSING THE RESET BUTTON:

The procedures for this operation are fully described in the preceding section. Go to LARGE TURNTABLE section, Step 5.

NO DATA TO / FROM TURNTABLES

If you are reading this section, it's because you've determined that, for some reason, the position of a turntable is not being properly reported to the Big Important Board and on to the computer. To verify that this is the problem (if you haven't already done so), do the following test:

Turn on the computer, go to the Main Menu, and select SHOW ADJUSTMENT UTILITIES. Next, choose READ TURNTABLE L.E.D.'s. On the next screen, find the name of the turntable in question and note the position number next to it. Have someone manually rotate the table while you watch the screen to see if the position numbers properly increase or decrease as the table moves.

GOOD READINGS - If the position numbers are reported accurately, then the infrared feedback system is fine, the data is reaching the Big Important Board intact, and the computer is interpreting the information correctly.

BAD READINGS - If the position numbers are NOT reported accurately (no change in number or erratic changes), then continue reading the information below.

- 1) Using the wiring diagrams in the COMPUTER / WIRING DIAGRAMS section, check the 24-pin and 26-pin connectors on the Big Important Board labeled Turntable Control and Show Play Card. Next, check the other end of the 26-pin cable where it connects to the Show Play Card in the computer (CAUTION: Make sure the computer is OFF anytime you are touching cables or cards in the computer.)
- 2) Disconnect the air line that feeds the large turntable before getting underneath.
- 3) Under the large table, check the other end of the 24-pin cable where it connects to the Large turntable interface board which is mounted on a cross-brace between Billy Bob and Fatz.
- 4) On the interface board, check all the other infrared connectors, paying close attention to the ones that relate to the table that isn't reading properly (consult the wiring diagram).
- 5) Finally, locate the feedback gear for the table in question and carefully inspect the infrared boards, the wire connectors, and the alignment of the boards relative to the feedback gear. Turn the table by hand and make sure the sets of holes pass directly between the infrared emitters and collectors. If any part of an infrared board has been damaged, it must be replaced.

Tol-O-Matic (Fluid Power)
ENG.
CC15SK18
18" Stroke
Cable Cylinders
(Naperville Only)

SIDE TURNTABLES

The side turntables operate on a slightly different principle than any other movement in the show. The side tables use a system referred to as air-over-oil, and are the ONLY components of the show that use hydraulic oil as part of the movement itself.

A side turntable is controlled by a pneumatic valve like any other pneumatic movement; however, the pressurized air from the valve is not directed to the cylinder ports (in this case, a cable cylinder). Instead, the air is directed into the top of one of two oil reservoirs. The pressurized air entering the top port of one reservoir forces the oil in the reservoir to exit the bottom port which is piped to one end of the cable cylinder. This, of course, causes the cable cylinder's piston to move toward the other end of the cylinder where the oil is allowed to exit the cable cylinder. This exiting oil is forced in through the bottom port of the other reservoir, which, in turn, forces the air in the top of that reservoir to the air valve where it is exhausted to the muffler.

Though unlikely, it is possible for the oil, over time, to bleed by the main seals of the cable cylinder, thereby creating a situation where one reservoir has a greater-than-normal amount of hydraulic oil, leaving the other reservoir with less than normal. These oil levels, according to the MAINTENANCE section, should be monitored for just such condition. In the event the reservoirs become unbalanced, they have been designed with a by-pass line to allow oil to flow from one to the other via a shut-off valve. Needless to say, the by-pass valve should remain shut during normal use!

OIL LEVEL CORRECTION:

1) Note the level of oil in the reservoir closest to the back of the stage. Next, use the override toggle switch to turn the stage, and note the oil level in the other reservoir (which is now closer to the back of the stage). If either one shows less than 1/4 inch of visible oil, a balancing adjustment is probably necessary. There are many complicated ways to do make the adjustment and one easy way:

2) The easy way is to disconnect the air hose from the props valve bank that supplies the turntable cylinder reservoirs (this valve bank is mounted on the board that supports the turntable cable cylinder).

- 3) Manually rotate the side turntable until it is exactly half way through the 180 degree turn. Going under the table, look at the reservoirs and compare the oil levels. The levels should be equal and each reservoir should be half full. If not, continue on.
- 4) Using a hex key, loosen and remove the plug on the top of each reservoir.
- 5) Open the valve on the by-pass line and allow a few moments for the oil levels to balance between the reservoirs. When the levels are equal, note how full they are. Each reservoir should be close to (but NOT over) half full. If the levels are under half full, add a little prescribed oil to one of the reservoirs and wait for the levels to balance again. Continue adding oil until the levels are equal and just under half full.
- 6) Close the by-pass valve. REPEAT - Close the by-pass valve.
- 7) Replace and tighten the hex-key plugs.
- 8) When you're out from under the stage, reconnect the air line.
- 9) Cycle the stage several times and recheck the levels (air bubbles in the system can affect oil levels).

SPEED ADJUSTMENTS:

The speed at which the side turntable rotates is controlled by large flow controls, one for each direction. Remember: the flow control meters the speed that the oil (in this case) is allowed to exit the cable cylinder. The flow controls are in-line, near the ports of the cable cylinder. When properly adjusted, the side turntable should take eight (8) seconds to travel from one extreme to the other.

PROPS / LIGHTS

PROPS:

The props of the show are pneumatic movements other than those of the characters themselves. Of course, in actuality, the word "prop" could apply to anything, but for simplicity purposes, its easier to consider props to be the movements that are controlled by the three "props" valve banks.

EXCEPTION 1 - The side turntables are, in fact, controlled by the props valve banks, but they are discussed in a different section.

EXCEPTION 2 - The Looney Bird computer swivel is actually a "prop," but is controlled by Looney Bird's valve bank (see chart 2B in THE CHARACTER section).

The three props valve banks (listed by the valve numbers) are outlined on chart 6A at the end of this section. The props controller, which is the bit-stripper connected to the interface board, is outlined by LED number on chart 6B. (If your show is not a full three-stage show, then some of the listed props may not apply to your show.)

STAGE LEFT - The stage left props valve bank is mounted on the board that supports the stage turn cable cylinder and air-over-oil reservoirs. (Valve #1 turns the left stage). Valves #2 through #4 control the rabbit ears on top of the large screen TV box. These particular four movements each use a single-acting cylinder referred to by its brand name as a "Clippard" cylinder. Unlike a double-acting cylinder that requires pressurized air to the rear port to extend the cylinder and pressurized air to the front port to retract the cylinder, Clippard cylinders are, in their starting position, retracted by an internal spring and only have one air port at the rear of the cylinder to extend the shaft when pressurized. If you look at the valve bank you'll notice that the **B** ports of the valves that control the rabbit ears are plugged. Since the pressure from the valve's **B** port is normally used to return the cylinder to its starting position, these ports are not used with Clippards due to the internal return-spring. When the valve is shifted (movement ON), the valve's **A** port is pressurized, the air enters the rear of the Clippard, and the cylinder extends, compressing the spring. When the valve is unshifted (movement OFF), the valve's **A** port is no longer pressurized and the Clippard's internal spring retracts the cylinder. Looking at the valve bank, you'll also notice that each single air line from each valve has two flow controls instead of one. The flow control with the arrow pointing away from the valve bank meters the air going toward the cylinder when the movement is ON. The other flow control, with the arrow pointing toward the valve bank, meters the movement going OFF.

CENTER STAGE - The center stage props valve bank is normally located on the back of the stage, near the large turntable air motor. This valve bank controls the left and right (imitation) speakers and the curtains. The speaker cylinders are standard, double-acting cylinders, and the curtain cylinders are long-stroke, cable cylinders. The flow controls for all of the movements on this valve bank are located near the cylinders themselves.

STAGE RIGHT - The stage right props valve bank is mounted on the board that supports the stage turn cable cylinder and air-over-oil reservoirs. (Valve #1 turns the right stage). Valve #2 controls the hacienda window that opens to expose the Looney Bird head. Valve #3 operates the coconut that drops down and appears to hit Beach Bear on the head. Both of these props are actuated by long-stroke, double-acting cylinders mounted inside the hacienda wall behind Beach Bear.

The cables that power the three props valve banks come directly from the interface board mounted next to the props bit-stripper in the electrical panel box behind the stage (this is the box that has the override toggle switches).

LIGHTS:

As mentioned much earlier in the manual, the lighting bit-stripper is a standard bit-stripper board that has been slightly modified. All bit-strippers have a 26-pin connector and are normally designed to use pins 23-26 as common (+24vdc) and pins 1-22 to close the circuit (supply the ground) of the individual valve or, in the case of lights, solid-state relay. The lights bit-stripper has been modified to extend the normal 22 switches to 24 available switches. On the lights bit-stripper, only pins #25 and #26 are common (+24vdc).

From the lights bit-stripper, the 26-pin ribbon cable goes directly to the solid-state relay panel called the light "controller," mounted behind the stage. Inside the panel box are 24 relays. The lighting bit-stripper closes the low-voltage side of a relay which, instantly, closes the high-voltage (110vac) side of the relay, thereby turning on the light. Chart 6C shows the lights listed according the relay number.

NOTE: If your show is a full, three-stage show WITH karaoke, there will be two extra relays in the controller - one for the karaoke spot light and one for the applause sign. The 24vdc power to close these relays comes through a separate cable from the props bit-stripper (via the interface board to which the props valve banks are wired).

90 INTO
MANUAL
BOX
OVER-IDE

CHART 6A - VALVE BANK LAYOUT

PROPS VALVE BANKS - LEFT, CENTER, AND RIGHT STAGE

Valve	Stage-Left Bank	Type	Movement OFF positions (starting positions)	
			cylinder	prop movement
1	Stage-left turn	cable cyl.	n/a	large TV toward audience
2	Rabbit ear / top-left	Clippard	retracted	ear down
3	Rab. ear / top-right	Clippard	retracted	ear down
4	Rab. ear / bot.-left	Clippard	retracted	ear down
5	Rab. ear / bot. right	Clippard	retracted	ear down

Valve	Center Stage Bank	Type	cylinder	prop movement
1	Stage-left curtain	cable cyl.	n/a	curtain down
2	Center stage curtain	cable cyl.	n/a	curtain down
3	Stage-right curtain	cable cyl.	n/a	curtain down
4	Left speakers	cylinders	retracted	speaker cone pulled back
5	Right speakers	cylinders	retracted	speaker cone pulled back

Valve	Stage-Right Bank	Type	cylinder	prop movement
1	Stage-right turn	cable cyl.	n/a	Beach Bear toward audience
2 *	Hacienda window	cylinder	extended	window closed
3	Coconut drop	cylinder	retracted	coconut up in tree

* On this movement, there are two small, in-line pressure regulators. They are adjusted to lower the normal 80 psi down to about 25 psi.

UNDER THE
RIGHT
STAGE

WIRE FOR DIAGRAM MANUAL BOX OVERRIDE

CHART 6B - PROPS CONTROLLER

LED#	Function	Valve bank	Valve #
1	Stage-left turn	SL	1
2	Rabbit ear / top-left	SL	2
3	Rabbit ear / top-right	SL	3
4	Rabbit ear / bottom-left	SL	4
5	Rabbit ear / bottom-right	SL	5
6	Left speakers	CS	4
7	Right speakers	CS	5
8	Stage-left curtain	CS	1
9	Center stage curtain	CS	2
10	Stage-right curtain	CS	3
11	Stage-right turn	SR	1
12	Hacienda window	SR	2
13	Coconut drop	SR	3
14 *	Applause sign		
15 *	Karaoke spot light		
16	Not used		
17	Not used		
18	Not used		
19	Not used		
20	Not used		

* Only used for shows with Karaoke. The wires from these two connectors (along with a common wire) are routed to two solid-state relays in the lighting controller.

SL = Stage-left CS = Center stage SR = Stage-right

CHART 6C - LIGHTING CONTROLLER

Relay	Light (Lit object)	Type	Gel color	
1	Note #1 - yellow note	neon	n/a	
2	Note #2 - blue note	neon	n/a	
3	"Rock-afire" neon	neon	n/a	
4	Note #3 - pink note	neon	n/a	
5	"Explosion" neon	neon	n/a	
6	White circle on backdrop wall	spot	green	
7	Heart on backdrop wall	spot	blue	
8	Top-left speaker	spot	purple	
9	Top-right speaker	spot	yellow	
F 10	EQ (fake) on backdrop wall	spot	blue	
F 11	Bottom-right speaker	spot	purple	
12	Yellow star on backdrop wall	spot	red	
F 13	Bottom-left speaker	spot	blue	
F 14	Organ (fake) on backdrop wall	spot	blue	
Lights 15	Stage-right floor spot	spot	yellow	
Lights 16	Stage-left floor spot	spot	blue	
SPOTS OUT FRONT	17	Stage-left character spot	spot	none
	18	Stage-right character spot	spot	none
	19	Center stage left character spot	spot	none
	20	Center stage center character spot	spot	none
	21	Center stage right character spot	spot	none
22	Note #4 - purple note	neon	n/a	
23	Looney Bird window light	bulb	n/a	
24	Dook window (on house)	bulb	n/a	
25 *	Applause sign	bulbs	n/a	
26 *	Karaoke spot	spot	none	

* For Karaoke shows only

MAINTENANCE

Routine maintenance on the show is more than important - it is absolutely necessary. The only difference between a well running show and a not-so-well running show is regular maintenance. As with any mechanical product, there will always be points of friction that require lubrication, and a small amount of normal wear that will affect certain adjustments.

For your convenience, the show is equipped with automatic oilers that handle the internal lubrication of all cylinders and air motors. There are only a few items on the show that require routine MANUAL lubrication: eyelids, eyes, turntable chains, and some character pivot points.

As for wear, with proper lubrication and adjustments, there should be a minimal amount. However, even a tiny amount of normal wear can affect the speed of character movements and turntables; hence, at the risk of sounding redundant, we cannot put enough emphasis on the importance of following the suggested schedules in this section.

DAILY, WEEKLY, and MONTHLY maintenance schedules appear on the following pages. It is suggested that you make plenty of photo copies of each schedule to use as checklists as the maintenance is performed. (Keep the originals in the manual for future copying.)

-- GO ON TO THE NEXT PAGE --

-- DAILY --

- * Before turning on air, check all oilers and fill as needed with 10W non-detergent hydraulic oil.
- * Follow the start up procedure, then visually inspect all characters for proper stance as described in THE CHARACTERS section. Any movement that is not in its proper starting position at this point requires your attention to find out why. Fixing any small problems NOW will prevent damage.
- * Look at the eyes and eyelids of each character for signs of sticking or lack of lubrication, and lubricate as needed.
- * Visually check the arms and shoulder areas of the characters for costume pinching or pulling.
- * Visually inspect the stages and props for any abnormal wear or damage.
- * Listen carefully for air leaks in the characters or under the stage. Don't allow air leaks to go without repair - aside from affecting movements, there is a small amount of oil mixed with the air that will soil parts surrounding the leak.
- * Brush fur and blow off characters that don't look their best. Doing this every couple days, needed or not, will prevent the fur from matting and keep the costumes clean.
- * Play a couple shows, watch for obvious mechanical problems, and make sure the audio system sounds normal.

-- WEEKLY --

- * Drain water from compressor air tank. Drain water from drier.
- * Drain water from air filter next to the pressure regulator.
- * Turn the air on and follow the normal start up routine, check pressure gauge for 80 p.s.i., and adjust pressure regulator if necessary. Never vary from 80 p.s.i.!
- * Using override toggle switches, cycle curtain cylinders and check for proper operation. Watch for binding cables and/or loose or missing weights.
- * Look under each side turntable and note the oil level in the reservoir closest to the back of the stage. Then, using the toggle switches, rotate both side turntables and check the oil levels in the other two reservoirs (which are now closest to the back of the stage). If any of the four reservoirs has less than 1/4 inch of visible oil at any time, refer to SIDE TURNTABLES section for instructions. Check for oil leaks on the fittings and around the cables where they enter each end of the cylinder.
- * Thoroughly inspect each character for proper stance. Carefully note the position of the arms, head, and body. Check for any excess free movement. When in doubt, remove the costume to inspect suspicious "sloppiness" or "looseness" in any part of the character.
- * Lubricate eyes and eyelids using CEI eye lube ONLY. Remove any old lube first, using a soft cotton cloth. Do Not use paper towels or napkins.
- * Use SHOW ADJUSTMENT UTILITIES to check the speed settings of the large turntable and the three character (small) turntables. Tables that are too slow will affect the choreography and need to be adjusted ASAP. Tables that are too fast will cause damage and breakdowns, and MUST be adjusted NOW.

Adjustment guidelines:

Large turntable - 13.5 to 14.5 seconds; ideally, 14 seconds

Small turntable - 6.1 to 6.5 seconds; ideally, the fastest setting within the range that does NOT allow the turntable to coast into the stop mechanism. While making adjustments, watch the feedback gear to see if the stop-bolt is hitting the stop-pin at the end of the rotation in either direction. If it does, slow that direction down (a very small amount at a time) until the stop-bolt comes to rest just before the stop-pin. This will achieve the quickest, SAFE speed.

-- MONTHLY --

- * Use the AUTO ASSIGN FOR ADJUST feature of ADJUST MOVEMENTS to check the speed of each pneumatic movement of each character. Select the first movement on the list (Mitzi is used as the sampling list for this feature), then select 1.0 SECOND TIMER to cycle that movement on all the characters at the same time. This feature not only saves time, but allows you adjust the speed of the movement AND synchronize that movement on all the characters simultaneously. The guidelines for setting all the movement speeds are outlined in THE CHARACTERS section. As with the turntables, a movement that is too slow will affect the choreography and should be adjusted ASAP, but a movement that is too fast will surely cause damage and MUST be adjusted immediately. If a particular movement is suddenly much too fast, correct the speed, but be suspicious of a possible flow control problem and pay close attention to that movement over the next few days. If a movement is suddenly much too slow, check immediately for any physical binding or interference with the movement. Also, listen carefully for any air leaks while the movement is cycling. If there is no apparent reason for the slowness, correct the speed, but treat the condition as a possible flow control problem and watch it carefully for a few days to see if it reoccurs.

- * As above, use the AUTO ASSIGN FOR ADJUST feature to check the servo movements (eyes and eyelids) of each character. Servo speeds are not adjustable, but it is important to check them for smooth, uninhibited movement. A "sticky" eyelid or eye can damage the servo motor and/or the linkage. Check the eyes and eyelids for proper lubrication as described in the WEEKLY schedule.

- * Each character of the show should be internally inspected once every three months. Therefore, if your show has three characters, choose one for each month; if your show has six characters, select two for each month. This process does not take very long! Following these instructions will greatly reduce unusual wear, prevent internal damage, and significantly add to the lifetime of the character.
 - 1) Once each month, remove the entire costume and mask from the scheduled character(s).

 - 2) Literally start at the top of the head. Carefully inspect every visible part of the character all the way down to the feet. (If you disconnected the air to remove the costume, reconnect it now - it will make it easier to notice abnormal looseness in the character.)

3) Check for any loose screws, bolts, nuts, or shaft collars. REMEMBER: There are many bolt/locknut combinations acting as pivoting bolts throughout the character, and over-tightening them will hamper movement and possibly cause damage. When in doubt, refer to THE CHARACTER section for help in determining the difference! All hardware that is supposed to be tight should be checked (with tools) for tightness. All pivoting bolts should be just loose enough to spin freely, but should not have excess "end play" (defined in THE CHARACTER section).

4) After inspecting all the components of the character, expose the valve bank and manually actuate each movement at least a dozen times. The movement should be smooth and steady. There shouldn't be ANY binding or slamming.

5) If any part needs to be replaced, now is the best opportunity to replace it. If you don't have the required part on hand, order it right away. NOTE: If necessary, a movement can be temporarily stopped (while waiting for a new part) by closing the flow controls for that movement. You can avoid repair delays by keeping the spare parts kit stocked.

6) Make sure all clear plastic moldings are properly in place, then replace the mask and costume. With the character fully dressed, check the movement speeds one more time for correct adjustment.

*** CAUTION: Before performing the next few steps, disconnect the air line that feeds the large turntable air motor. Being under the center stage is safer with the air to the motor disconnected.

The next few steps require being under the center stage (the large turntable).

* Inspect the main harness that feeds the large turntable and the air lines/wire harnesses that are suspended below each cradle. Look for wear or cuts in the air hoses or protective cable sleeving. Worn or cut air hose should be replaced. Worn wire harnesses, if caught early enough, can be protected with new sleeving.

* Check the chains on the three character cradles for proper tension. (The diagram at the end of this section briefly describes the process of checking and/or adjusting chain tension.)

-- MONTHLY (cont.) --

- * Use a blow gun to clear away any dust on the four sets of infrared boards.
- * Check (for tightness) all bolts associated with the 6-inch wheels that support the center stage large turntable and the side stage turntables.
- * Inspect large air motor drive tire for wear. Remove any rubber tire particles with a vacuum. Replace the tire if necessary.
- * Check (for tightness) all 1/4-20 flat-head bolts that secure the diamond plate to the outside of the large turntable. At the same time, check the 1/4-20 flat-head bolts that secure the running boards (the curved plastic boards that ride on the 6-inch wheels) to the bottom side of the large turntable. If looseness is a problem, you can remove the bolt, lightly coat the threads with NON-permanent Loc-Tite thread sealer, and re-tighten the bolt in place.

- *** When you are finished under the stage, remember to reconnect the air line.

- * Perform routine maintenance on your air compressor as prescribed by its manufacturer.

- * Do general housekeeping, e.g., dust the props, vacuum the set, organize your spare parts area (re-order anything that you have used).

- * Finally, use a TOP QUALITY video tape head cleaner on your tape deck(s).

CHAIN ADJUSTMENT: When a chain is stretched around two sprockets, like a v-belt is stretched around two pulleys, the tension is determined by "deflection." The deflection can be checked with MODERATE thumb pressure applied midway between the sprockets. The simple drawing below represents two sprockets and the chain between them. The deflection of either chain on the character cradle should be no less than 1/8 inch and no more than 3/8 inch. The air motor is attached to the cradle by a bracket with four bolts through slotted holes. These slots allow for tension adjustment of the drive chain. The other chain, the feedback gear chain, can only be adjusted by loosening the feedback shaft flange bearing bolts, removing excess chain slack, and retightening the bolts.

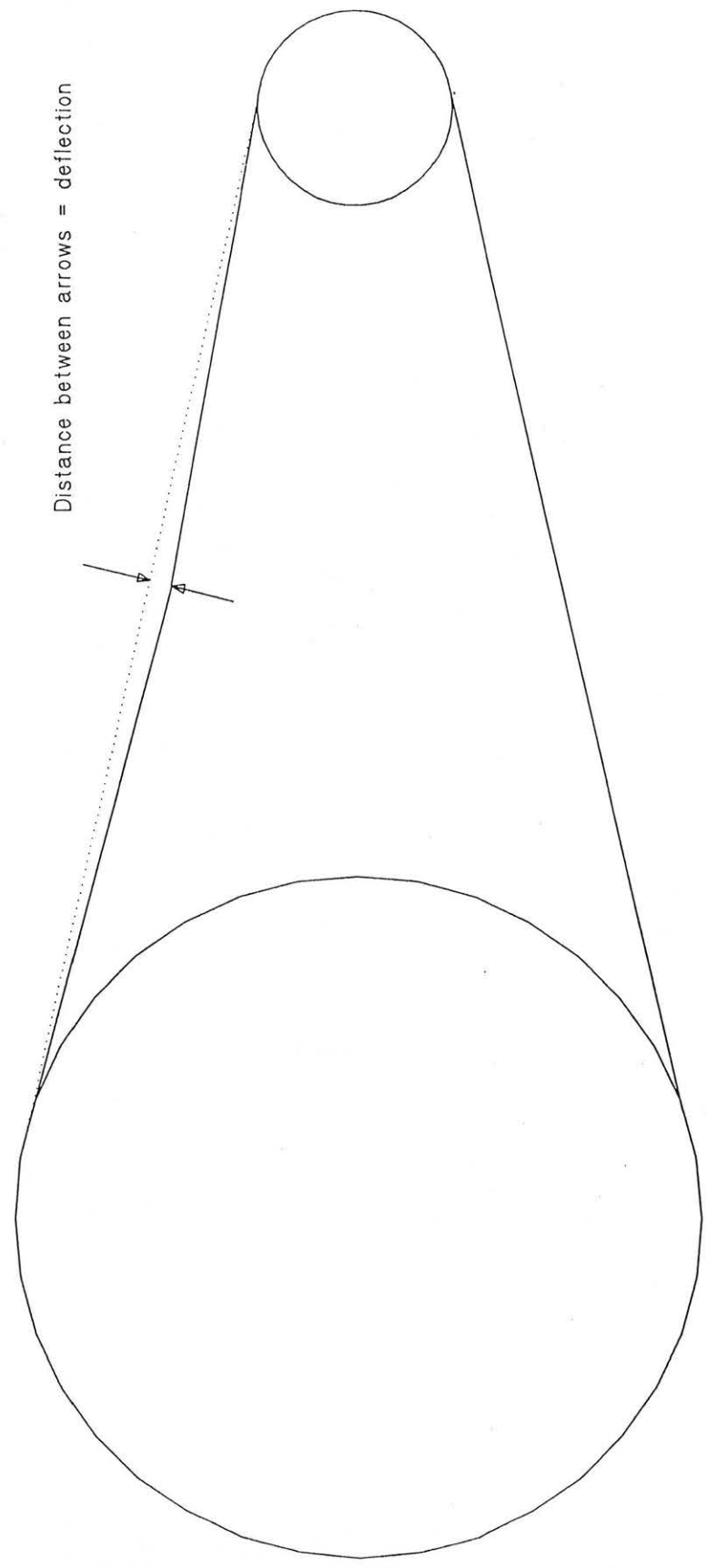

Title: Chain adjustment tolerances

Date: 06/18/95

Scale: Representational

Tolerance (unless indicated):

Creative Engineering, Inc.
 47 West Jefferson Street
 Orlando, Florida 32801

TERMS AND DEFINITIONS

AIR FILTER: Located between the main air source line and the pressure regulator, the filter does two things: it has a filter cartridge that prevents foreign air-borne particles from entering the system, and it has a large clear bowl that allows water vapor to collect in the form of water to be drained by using the drain cock at the bottom of the bowl.

AIR MOTOR: Actual motor that is powered by pressurized air instead of electricity or fuel. Air motors are used to move the large turntable and the three small (character) turntables. Air motors can spin in either direction by controlling the direction of air flow.

BIG IMPORTANT BOARD: Large printed circuit board mounted in the control rack that performs many duties - switches audio inputs between the two video decks, controls all center stage turntables (reads positions and operates air motors), controls strobe light, sends video to TV's, and patches data through to bit-strippers for lights, props, and stage-right characters. (This board was once referred to as the Turntable Board.)

BIT-STRIPPERS: Individual, large printed circuit boards that interpret show-play data from the computer. They are ultimately in-charge of shifting valves, controlling servos, and controlling spot lights and neon lights.

BLOW-BY: The condition of air in one end of a cylinder leaking past the main piston seal into the other end of the cylinder, lessening the normal force of the cylinder. A cylinder with severe blow-by may hesitate greatly or even not move at all when the valve is shifted.

BOARDS: Plug-in boards inside the computer. There currently can be as many as six boards in the computer. Their slot numbers and names are:

- 1) Decoder,
- 2) Show-Play,
- 3) Director of Communications (DOC),
- 4) RS-232,
- 5) Disk Interface,
- 7) Lightpen (and modem).

CABLE CYLINDER: Long stroke cylinder with a cable attached to each end of the piston. The cables exit the cylinder at each end, travel around pulleys, and attach to a common bracket. They are used for raising curtains and turning the side turntables.

CLEVIS: Slotted block of metal threaded onto the piston shaft of a cylinder used as a front mount mechanism. The slot forms two tangs. The tangs have holes in which the floating pin spins. Clevises are currently used for the front mount of each of the following: *head up, shoulder raises, wrists, and knee bend.*

CLIPPARD CYLINDERS: Single-acting cylinders currently used in the large screen TV's rabbit ears.

COSTUMES: Clothing, latex parts, and furring worn by the characters.

CYLINDER: Pneumatic device that is cylindrically-shaped with a piston shaft (rod) extending from one end that travels straight out (extended) and straight back (retracted). The cylinder is the most common device used to actuate movement. Most cylinders are double-acting, meaning they have two air lines and can be forced (by air pressure) to move in either direction. The cylinders used in the rabbit ears on the large TV are single-acting, meaning they have one air line to extend the cylinder and an internal spring to retract the rod.

CUSTOMER PANEL: Show Selector system interface stand that sits in front of the stage and allows customers to choose the next song.

END PLAY: The distance a floating pin can travel linearly in a pivot point before the bolt-head, locknut, or shaft collar stops the pin from going any farther. End play should be kept to a minimum - 1/32 inch is more than enough.

FEEDBACK GEAR: Large sprocket used on each character turn table and the large turntable. Feedback gears rotate when the turntables rotate. They have a series of drilled-hole combinations that permit light to travel from the infrared light emitters to the collectors. The specific combinations report the exact position of the turntable to the Big Important Board.

FLOW CONTROL: Device used to control (or meter) the rate at which exhaust air is allowed to flow back to the valve bank from the cylinder, rotary actuator, or air motor.

INFRARED BOARDS: Printed circuit boards (in pairs) that straddle a feedback gear and report the position of the large turntable and character turntables to the Big Important Board.

LOCKNUT: A specially designed nut with a nylon ring molded into the top end of the nut. The purpose of the nylon is to very firmly grip the threads of the bolt onto which the nut is threaded. Locknuts are used in two capacities. First, they are used all over the character in place of regular nuts (usually with lock washers) to firmly tighten two parts together. Second, they are used in many pivot points along with an aircraft bolt to become a floating pin. In this application only, the nut is left "slightly" loose to allow the bolt (pivot pin) to spin, and the nylon ring keeps the nut in its original location instead of vibrating loose and falling off (as would a regular nut).

MAIN HARNESS: The two air hoses and several electrical cables, all bundled together in protective sleeving, that feed air and power to the large turntable. The main harness is literally pulled around by the harness hanger under the turntable as the table rotates. Also, each side turntable has a main harness, each containing one air hose and electrical cables.

MANAGER PANEL: Show Selector system interface panel (not accessible to customers), used by store personnel to start birthday songs or special promotional skits.

MUFFLERS: Foam-filled aluminum chambers used to muffle the air from the exhaust ports of the valve banks. Character mufflers are small and cylindrically-shaped. Mufflers for the props and character turntables are made of 2 x 2 aluminum box, roughly seven inches long.

OILERS: Located at the main air distribution manifold (and one located near large turntable air motor), they are automatic lubrication devices that inject a very small amount of oil into the air that passes through. The oil subsequently lubricates the cylinder, rotaries, and air motors. On the small oilers, the bowl unscrews for refilling. On the larger models, there is a black plug next to the adjustment knob that unscrews for filling. With either type, bleed down all air pressure before and after the oiler before servicing.

PAR 46 CANS: Colored lights used for special effects that require a 200 watt spot bulb.

PIVOT POINT: The apex, front mount, and rear mount of any cylinder-based movement. (See CHARACTER section for details.)

PLASTIC MOLDINGS: Vacuum formed plastic parts (usually clear) used to add form to the characters and prevent the costumes from rubbing the mechanisms. The standard character uses moldings for chest, back, upper arms, lower arms, upper legs, lower legs, shoulders, and skull.

PLUMBING HARNESS: Group of air hoses beginning at the quick release and running up through the character to the cylinders and rotary actuators. There are four harnesses for each character.

POWER SUPPLY: Converts 110 AC volts to one or more specific DC voltages. The main power supply is located on the bottom shelf of the audio/control rack, providing 5, 8.5, and 24 volts for the bit-stripper boards and valves. A smaller power supply sits behind the Big Important Board, providing +5, -5, +12, and -12 volts for the Big Important Board itself.

PROPS: Animated, cylinder-controlled devices aside from the characters themselves. On full shows, there are three props valve banks, one mounted on each side turntable (near the cable cylinder) to control side turntables, rabbit ears, coconut, and window; and one mounted near the large air motor to control curtains and imitation speakers. For details, see PROPS/LIGHTS section.

PUSH-LOC HOSE: Air hose of 1/4 or 3/8 I.D. (internal diameter) that can be pushed firmly onto special barbed fittings and require no clamps.

QUICK RELEASE: Two-piece devices with ten air hose fittings on each half that can be unlocked and separated to permit the complete removal of a valve bank away from a character. (There are a few smaller, two hose [single movement] quick releases used for props.)

REGULATOR: Maintains a constant air pressure for the entire show. The [pressure] regulator is located between the air filter and the main air distribution manifold. The regulator should be set to 80 p.s.i. at all times.

RODEND: A rodend is any pivoting device that screws on to or into the end of a cylinder shaft (rod) or threaded rod to create a pivot point. Some different types are solid block, clevis, and ball joint. (The ball joint type, or "spherical ball rodend," is often simply referred to as a "rodend" throughout the industry.)

SERVO: Small, internally geared motors (like those in model airplanes), used to move the eyes and eyelids. The speed and stroke of a servo are not adjustable - they are completely controlled by the bit-stripper board.

SIDE LOAD: A condition where the shaft (rod) of a cylinder is stressed sideways during the movement. Side load will lead to immediate seal wear and eventually metal-to-metal internal damage. Side load is the result of misaligned movement parts.

SPOTLIGHTS: High wattage, white lights used to light up a single character for accentuation (like solo singing). These lights have fixed irises and require a 500 watt EHD bulb.

STANCE (Proper): The position of the character with all movements in their proper starting positions, i.e., ALL movements OFF.

STARTING POSITION: Position of a character when all movements are turned OFF.

SYNC: Short for "synchronization," it means that a turntable and its chain-driven feedback gear are rotating properly with relationship to each other. (Side turntables are cable cylinder actuated and don't have feedback gears.) Turntables that go beyond their normal extremes (clockwise and counterclockwise) will no longer be in sync.

TRANSFORMER: Used to power the neon lights, they are mounted on back side of the rear walls of the show. These transformers produce output voltages around 10,000 volts and should be treated with the utmost respect. DO NOT tamper with them unless you are experienced with this type of equipment.

TRIAC: Solid-state relay device used to control high-voltage AC lighting. An isolated, low-voltage circuit on one side closes the high-voltage gate on the other side. Triacs are located in the electrical panel next to the breaker box.

VALVE: Electrical/mechanical device that utilizes a electric solenoid to shift a mechanical valve to and fro to control the flow of pressurized air. A typical valve has an inlet port, exhaust port, and two line ports that go (by hose) to the cylinder or rotary actuator. One line port is normally pressurized while the other is normally open to exhaust freely. When the solenoid is energized and the valve shifted, the roles of the ports reverse. This type valve is the most common.

VALVE (air motor): These valves work differently than a valve for a cylinder. Air motors require a constant flow of air to operate; consequently, when the motor is off, the air motor valve's OFF position has both line ports closed - no air to the motor, no air from the motor - the motor is still. The valve can then be shifted one of TWO directions away from the middle OFF position. One shift delivers pressurized air to one line port and exhausts the other, spinning the motor in one direction. The other shift simply does the opposite with the line ports, spinning the motor in the other direction.

VALVE BANK: Series of valves bolted together in-line to allow for one main air inlet and one exhaust outlet, as opposed to each and every individual valve having its own set. In the case of a character, the double banks mounted to a base board and interconnected by hoses and wires are collectively called the Valve Bank.

"Big Important Board"

Connector For Remote

8-pin (Left to Right)

Brown

Red

Green

Blue

Black

space - empty

Red - 5v

Black - Ground

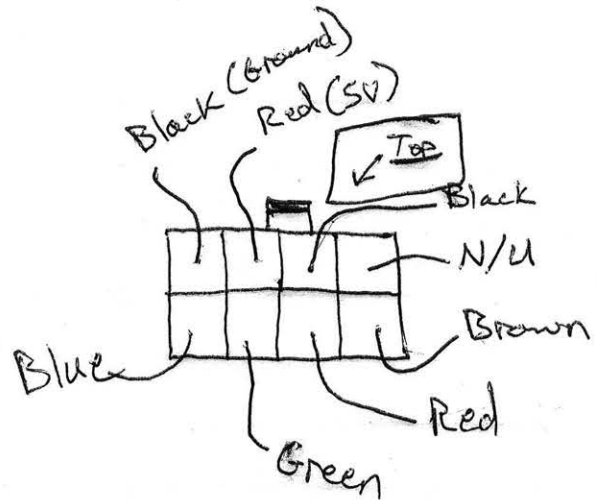

The Remote

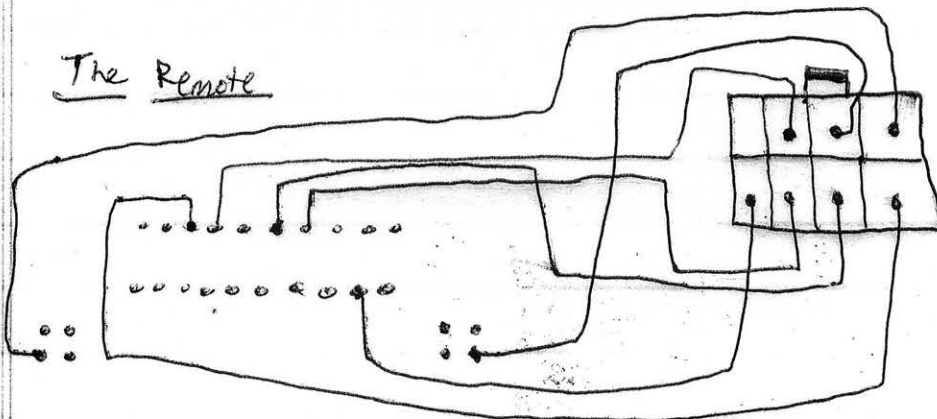

Show Wiring

Fuse Interface Bd

- 1 → Power In from Supply
- 2 → Beach Bear (Power To)
- 3 → Not Used
- 4 → Not Used
- 5 → Not Used
- 6 → Power To Center stage Power Dist. Bd.
- 7 → Power To Props
- 8 → Power To Looney Bird
- 9 → Power To Lights
- 10 → Power To Docks

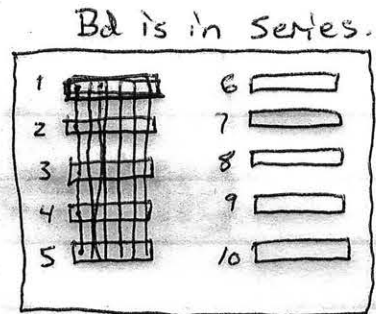

ALL Connectors have the same voltage.

7-Pin

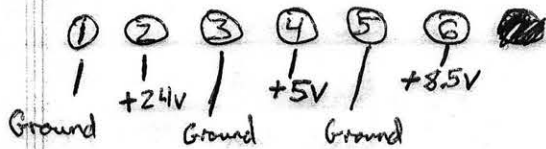

On Center Stage Power Connector
→ +5V wire does not go thru a fuse.

Turntable Logic Bd

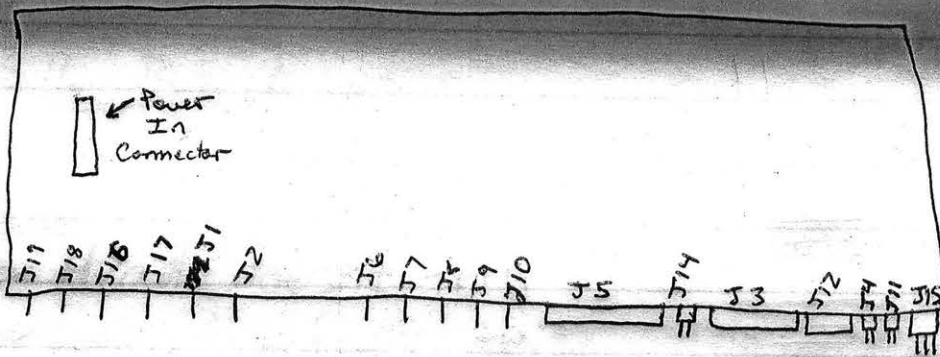

Power In Connector → 6-pin 

Power Connector → Power In from AC/DC Transformer.

J19 → ^(Red) Audio In from VCR #1

J18 → ^(Black) Audio In from VCR #1

J16 → Red Audio In from VCR #2

J17 → Black Audio In from VCR #2

J1 → Audio In from Mixer

J2 → Audio In from Mixer

J6 → Audio In from Computer

J7 → Data Out to Turntable Bd.

J8 → Not Used

J9 → Not Used

J10 → Not Used

J5 → From Center stage Turn Table

J14 → Not used

J3 → From Computer

J12 → Control for VCR #2

J4 → Not Used

J11 → Not Used

J15 → To Main Turn Table Valve's

TURNABLES

CENTER STAGE	68-72B
MITZI	77-80B
BILLY BOB	85-88B
FATZ	93-96B
STAGE RIGHT	41B
STAGE LEFT	42B

CURTAINS

STAGE LEFT CURTAIN	58B
STAGE RIGHT CURTAIN	59B
CENTER STAGE CURTAIN	60B

LIGHTS

STAGE LEFT SPOT	101B
STAGE RIGHT SPOT	102B
CENTER STAGE LEFT	103B
CENTER STAGE CENTER	104B
CENTER STAGE RIGHT	105B
ORGAN LIGHTS	106B
COLOR LIGHTS #1	109B
COLOR LIGHTS #2	110B
COLOR LIGHTS #3	111B
COLOR LIGHTS #4	112B
COLOR LIGHTS #5	113B
COLOR LIGHTS #6	114B
COLOR LIGHTS #7	115B
COLOR LIGHTS #8	116B
COLOR LIGHTS #9	117B
STAGE RIGHT FLOOR SPOTS	57B
STAGE LEFT FLOOR SPOTS	74B
STAR STROBES	118B
LOONEY BIRD LIGHT	97B
DOOK WINDOW	98B
STROBE	81B
ROCKAFIRE NEON	108B
EXPLOSION NEON	119B

CONTROLS

STOP	99B
REWIND	100B

Turntable Positioning Exercise

BACKGROUND: For each character table, there are 15 readable positions, numbered 0-14, with number 15 reserved to indicate "in between." The center position is 7. Turning the table counterclockwise, the position numbers decrease to 0; turning the table clockwise, the numbers increase to 14. There will usually be "garbage" numbers just before and just after the true position number - this is completely normal. For example, if the table was in between positions 7 and 8 (showing a 15), then turned slowly, by hand, clockwise, you might encounter a couple garbage numbers (higher than 8) until reading an 8. If you were to keep turning, you might get a couple more garbage numbers just after the 8 before getting a 15 again (showing that it is in between 8 and 9). Remember - the garbage numbers will always be higher than the real position number.

Suppose you were to choose a character table at random that was reading 15, begin turning it counterclockwise, and saw the following sequence: 15, 11, 7, 4, 9, 15. If you stopped and backed it up a bit to 4, you would be at position 4. You won't always encounter garbage numbers - just most of the time.

NOTE: The large turntable works exactly the same way, except there are 31 large table positions numbered 0 through 30, and the number 31 indicates "in between."

EXERCISE: After your show is installed and tested (when you have about 30 minutes while the store is closed), do the following to help familiarize yourself with some of the Show Adjustment Utilities functions and provide yourself with permanent alignment marks for your character turntables:

- 1) At the main menu, choose POSITION CHARACTERS IN FRONT. Press number 4 which is FATZ AND MITZI FRONT. As shown in diagram 3A (in the CHARACTER TURNTABLES section), this will position Fatz and Mitzi toward the front of the stage, and Billy Bob at the rear of the stage, directly in front of the big white circle on the back wall. At the same time, the small turntables have been positioned so that all three characters are facing directly forward (or close to it). All four tables are now in their "center" positions. The center position for a small table is exactly half way between the fully clockwise extreme of the table and the fully counterclockwise extreme. (The center position of the large turntable is Billy Bob to the back of the stage, roughly centered between left and right.) A small turntable, from extreme counterclockwise to extreme clockwise, rotates slightly more than one and one-half revolutions (about 550 degrees). Consequently, when a small table is at its center

THE NEW ROCK-AFIRE EXPLOSION USER'S MANUAL AND REFERENCE GUIDE (Variation 1 - Odyssey Fun World)

Date of Origin: 1995
Archived: 4-15-19
Submission by mafia
Version 1.0

The documents contained herein are for educational use only.
Please do not replicate, redistribute, or make any unauthorized
printings. All intellectual property including characters,
artwork, photography, and slogans are trademark and/or
copyright their respective owners.

