

NEW MANUAL
MISC NOTES IN BACK

The New
Rock-a-fire Explosion®

Odyssey Fun World, Tinley Park

**User's Manual
and
Reference Guide**

Table of Contents

- General Description
- Start up / Shut Down
- Audio / Control Rack
- Computer / Wiring Diagrams
- Big Important Board
- DC Power Supply Circuits
- Operating System
- Show Adjustment Utilities
- The Characters
- Character Turntables
- Large Turntable
- Large Turntable Sync Problem?
- No Data To / From Turntables
- Side Turntables
- Props / Lights
- Maintenance
- Terms and Definitions

Odyssey Fun World

ODYSSEY FUN WORLD

general description (4)

start up / shut down (1)

audio / control rack (2)

audio / control rack - with search deck

audio system - nrae with show selector

computer / wiring diagrams (1)

wiring diagram - full show with show selector

big important board (1)

big important board - standard

dc power supply circuits (1)

bib power supply

main power distribution

large turntable interface board

limit switch circuit

operating system (1)

show adjustment utilities (2)

the characters (10)

chart 2a - valve bank layout - billy bob - fatz - mitzi - beach bear - dook

chart 2b - valve bank layout - looney bird

diagram 2c - typical cylinder (cross-section view)

diagram 2d - typical rotary actuator

diagram 2e - pivot point example

character turntables (6)

diagram 3a - fatz and mitzi front (utilities: position characters)

diagram 3b - cradle

large turntable (5)

diagram 4a - fully clockwise position (#30 front-and-center)

diagram 4b - fully counterclockwise position

diagram 4c - beyond fully clockwise position, limit switch triggered

diagram 4d - beyond fully counterclockwise position, limit switch triggered

diagram 4e - #1 front-and-center

diagram 4f - large turntable feedback assembly

large turntable sync problem ? (3)

no data to / from turntables (1)

side turntables (2)

props / lights (2)

chart 6a - valve bank layout - props valve banks - left, center, and right stage

chart 6b - props controller

chart 6c - lighting controller

maintenance (6)

chain adjustment tolerances

terms and definitions (5)

appendix a

GENERAL DESCRIPTION

This introductory section is designed to take you on a quick tour of the show - from the VCR's and computer to the valve banks, air motors, lights, and props. The rest of the sections are devoted to specific areas of the show.

After following the start up procedure at the end of this section, the show is ready to play. In general, here's how all the computerized components of the show work:

The heart of the system is the computer (currently a modified Apple). The computer programs and cards do most of the decision-making while a show is running. For example, on a full show with Show Selector, the computer would do all the following: decide which song to play via the selector panels; instruct the appropriate VCR to play the show; decode the show data from the VCR video; send show data to the characters, turntables, and props; control time-outs between shows and the frequency of replays; and much more. In addition, in the utilities mode, the computer can perform dozens of diagnostic tests, manually cycle any movement of the show, and even send and receive e-mail with the optional modem. The computer is the central interpreter that synchronizes all the other components of the show.

All of the show information is contained on the video tapes - the video, the stereo audio, and the control data (encoded in the video). There are two VCR decks used for most shows. The first deck is a professional RS-232 controllable "search deck" (currently, a Panasonic). There are two key features of this deck, the first being the RS-232 connection between the deck and the RS-232 card in slot #4 of the computer. This connection gives the computer direct and complete control over the VCR deck. The other key feature is the internal counter that tracks the exact position of the tape and can be accessed by the computer, i.e., the computer tells the VCR to "go to" a particular spot on the tape (the beginning of the selected show), and the deck automatically rewinds or fast-forwards to that exact position. (A show with neither Show Selector nor Karaoke would not have this search deck.)

The second VCR deck is a commercial-grade deck with a standard remote control unit that has been wired to the Big Important Board (described later). For most shows, this deck is called the "thank you" deck because it's duty is to play a short skit before each actual show is played from the search deck. The thank you shorts are played back sequentially one at a time until the last one is played, at which point the tape is rewound to the beginning. The play, stop, and rewind commands come from the computer via the remote control. If it was possible to get a

quality commercial-grade deck with a remote jack on the back, we would certainly use it; however, the days of "wireless" remotes are here to stay, so no one makes a deck with a "wired" remote jack anymore. Just as you would with a home VCR, please keep the remote transmitter and the VCR's dust-free to ensure trouble-free operation. (A show with neither Show Selector nor Karaoke would ONLY have this deck.)

From the video decks, the video and audio travel different directions (refer to the wiring diagram in the COMPUTER / WIRING DIAGRAM section while reading the information below):

VIDEO SIGNALS:

The video from both decks goes into two input jacks on the Video Decoder card in slot #1 of the computer. The Decoder separates the show control data (described below) from the video itself. The video is then sent on to the Big Important Board (BIB). The BIB, according to the programming, amplifies the signal and controls when the signal is then allowed to be sent back out to the TV(s). (Shows with Karaoke work a bit differently - see the BIG IMPORTANT BOARD section and the wiring diagram.)

SHOW CONTROL DATA:

The show control data leaves the computer at two output jacks on the keyboard-end of the Showplay card in slot #2 of the computer. The top output is referred to as the "top drawer" signal, the bottom as the "bottom drawer" signal (a throwback to a much older version of a computer that was housed in a small gray cabinet that literally has two drawers). The top drawer signal goes directly to Dook's bit-stripper, then on to the Large Turntable Interface Board where it splits off to supply show data to Billy Bob's, Fatz's, and Mitzi's bit-strippers. The bottom drawer signal goes to the BIB which has its own bit-stripper on board to collect the specific data necessary to control the large turntable, character turntables, and strobe light. The signal then leaves the BIB and continues on to the panel box that houses the lighting and props bit-strippers. From there, the signal passes to Looney Bird's bit-stripper and on to Beach Bear's bit-stripper. (Lite shows do not have Dook, Looney Bird, or Beach Bear.)

BIT-STRIPPER - The bit-stripper system consists of several individual boards (mentioned above), each having a particular set of functions. Each character of the show has its own bit-stripper board. The props and lights each have a bit-stripper board as well. (The exception is the bit-stripper circuitry for the turntables and strobe light which is integrated on the BIB.) These bit-stripper boards are nearly identical except for the 6801 processor that is programmed to make each board specific to its task (the lighting board is slightly modified).

Character bit-stripper boards use the show data to shift the individual 24vdc valves of the valve bank that control all the pneumatic movements of the character. Character boards also have a 6805 PROM to control the 5vdc electric servo motors that operate the eyes and eyelids. The props bit-stripper board essentially works the same way by shifting the 24vdc pneumatic valves that control the curtain(s) and side turntable props (if equipped).

On each bit-stripper is a line of LED's that indicate when a movement is ON. When the LED is lit, the controlled movement is ON. The LED's, in order (starting near the edge of the board), represent the following:

- LED # 01-21 pneumatic movements associated with that bit-stripper, e.g., LED #1 on a character is the mouth.
- LED # 22-27 servo movements on characters
- LED # 28 not used
- LED # 29-30 connected in parallel, these two LED's indicate when the board is accurately interpreting the show data from the computer - a condition referred to as "in sync." When the LED's are NOT lit, the board is in sync. If the LED's ARE lit, the board is not in sync and will not operate properly.

The lighting bit-stripper board uses the show data to switch the 24vdc inputs on the solid-state relays to close the high voltage side of the relays to power the lights. On the lighting bit-stripper, the LED's #01-24 represent the first 24 solid-state relays in the lighting controller (described in PROPS / LIGHTS section). As with all bit-strippers, LED's 29-30 are for indicating sync.

AUDIO SIGNALS:

The stereo audio leaves the VCR's and goes directly to the BIB at four input jacks (two for each VCR). The BIB determines which deck is in play, and passes that audio (left and right channels) out the two output jacks to the equalizer. From there, the audio goes to the SPL computer (if equipped), then to the crossover device which separates the lows-frequency tones from the high-frequency tones. The "lows" go to the mixing amp that combines both channels to mono, and then on to the subwoofer amp that drives the bass speaker under the stage, behind the front grill. The "highs" go directly to the main amp that drives the eight monitor speakers placed around the room (see the audio system diagram).

ANIMATION:

The animated components are in, basically, three different groups: character movements, props, and turntables.

CHARACTER MOVEMENTS - The eyes and eyelids of each character are controlled by electric servo motors (servos), while all other movements are pneumatically operated. The pneumatic movements are all controlled by the valve bank mounted underneath or behind each character. The valves are shifted (energized/de-energized) by the bit-stripper board according to the show control data. For example, when the *right arm raise* valve is energized, the arm raises; when de-energized, the arm returns to its starting position. Most character movements are actuated by air cylinders that extend and retract, while others use rotary actuators that rotate up to 90 degrees.

PROPS - Props are all other pneumatic movements outside of the characters. These movements include (on a full show) rabbit ears, imitation speakers, coconut drop, Beach Bear's window, computer swivel, curtains, and side turntables. The reason side turntables are on this list is because they are moved by an air cylinder and are controlled by "props" valve banks; however, side turntables are discussed separately from the props in the manual sections due to their unique air-over-oil design.

TURNTABLES - The center stage has one large turntable on which the center-stage characters travel, and each center-stage character is on its own, smaller turntable. These four turntables operate essentially the same way - each is moved by an independent air motor, each can be moved independently of the others, and each has an independent "feedback" unit to tell the computer system its current position and its direction of travel (when moving).

**** The above general information is just that - general. ****

**** Detailed information follows in separate sections. ****

**** Do yourself a favor - read it! ****

**** Questions? Call 407-425-1001 ^{11:00 H} ****

ASK FOR ALEX

START UP / SHUT DOWN

START UP PROCEDURE FOR NEW ROCK-AFIRE SHOW

- 1) Turn on all circuit breakers for show
- 2) Turn on compressor system
- 3) Turn on sound system from top down (EQ then amps)
- 4) Turn on computer monitor
- 5) Be sure show selector disk is in the disk drive
- 6) Turn on computer
- 7) Turn on RCA VCR (Thank you deck)
- 8) To start show selector system, press button labeled-
PRESS THIS BUTTON WHEN SYSTEM IS TURNED ON
- 9) System will rewind and reset each VCR and turn on
panel lights
- 10) You are ready for operation

SHUT DOWN PROCEDURE FOR ROCK-AFIRE SHOW

- 1) Turn off computer
- 2) Turn off sound system bottom up (amps then EQ)
- 3) Turn off all circuit breakers
- 4) Turn off compressor system
- 5) System is shut down

AUDIO / CONTROL RACK

The items in the rack are shown in the diagram at the end of the section. Following that is another diagram that shows the audio path of the entire show. The following information is a shelf-by-shelf, general description of the components, along with some helpful hints.

MONITOR - The monitor is monochrome and is subject to screen burn-in, so you are encouraged to keep either the contrast or brightness control set to minimum when the monitor is not being utilized. Some program prompts require the lightpen for making selections; therefore, you will have to make sure the contrast and brightness controls are set high enough for the lightpen to work properly. (When you're all done, darken the screen again.)
NOTE: There is no audio signal sent to the monitor.

AUDIO AMPLIFIER - This is a low-power audio unit (make and model may vary) used to match the volume of the audio of the Thank You deck to that of the Search deck. Audio levels are carefully controlled during recording, but slight level differences may be experienced due to differences in the VCR's themselves.

DISK DRIVE - A high density (1.44 Meg) drive that uses specially formatted disks supplied by Creative Engineering, Inc.
CAUTION: Do not attempt to copy a C.E.I. disk on a standard PC - it won't work!

COMPUTER - (See the **COMPUTER / WIRING DIAGRAMS** section)

SEARCH DECK (VCR #1) - Professional-grade, addressable search deck that is controlled directly and completely by the computer via the RS-232 cable between them. This deck, which plays the show tape, can locate the exact beginning point of any show/song according to the indexing information on the accompanying show disk. (Shows with neither Show Selector nor Karaoke will not have this deck.)

THANK YOU DECK (VCR #2) - Commercial-grade VCR controlled by the wired remote control to play a "Thank You [for pressing a button on the Show Selector]" skit prior to each show. (On shows with neither Show Selector nor Karaoke, this will be the only deck in the rack and will not play "thank you" skits as it will contain the sequentially played shows.)

BIG IMPORTANT BOARD - (See **BIG IMPORTANT BOARD** section)

SPL COMPUTER (Sound Pressure Leveling) - If equipped with your show, its purpose is to automatically adjust the volume of the audio according to background noise. If the area directly immediate to the show experiences extreme fluctuations in background noise, an SPL computer can appropriately balance the audio level to the noise.

EQUALIZER - In most circumstances, the equalizer should be kept flat (all levels at zero). If, however, you have specific experience in adjusting tones, make adjustments conservatively. Remember: what sounds specifically "good" to one person may not sound good to the general public. When in doubt, set the EQ flat.

SUBWOOFER AMP - Used to control the lowest bass tones, this amp powers the woofer behind the grill on the front of the stage. CAUTION: Adding too much bass can cause "rumbling" that will ruin the quality of the audio. Get more than one person's opinion to help set the levels in your room.

MAIN AMP - Used to control the volume level of the eight room speaker.

POWER SUPPLY - This the main DC power supply of the show that supplies the power for the valve banks, the lighting relays, the Big Important Board (24vdc only), and the infrared feedback circuitry.

Audio / Control Rack - with Search Deck

08/15/95

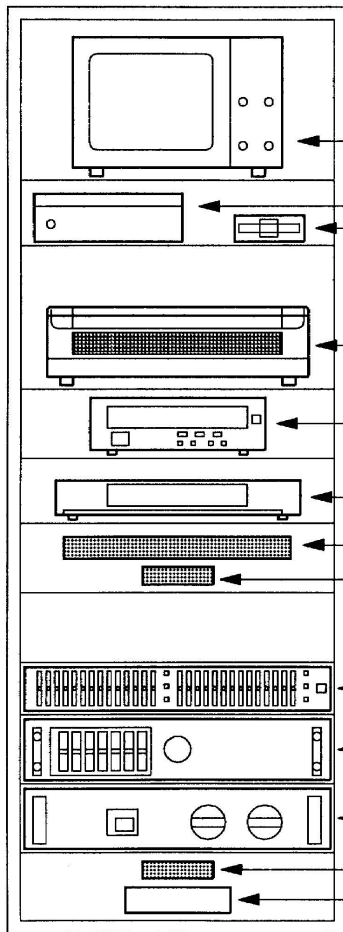

Computer Monitor

Audio amplifier for Thank You Deck (may be located elsewhere in the rack)

3 1/2 inch disk drive

Computer with keyboard

VCR#1 - Search Deck

VCR#2 - Thank You Deck

Big Important Board (once known as Turntable Board)

Power Supply for Big Important Board (toward the front of shelf)

ElectroVoice EQ-215 Equalizer

Yamaha P120 Subwoofer Amp

Yamaha P2700 Main Amp

Power Distribution Board (mounted toward the rear of shelf)

Main Power Supply (mounted toward the front of shelf)

NOTE: Two items not visible from the front of the rack are the Yamaha PN90 Crossover and the Line Summing Amp. These two units are accessible from the rear of the rack.

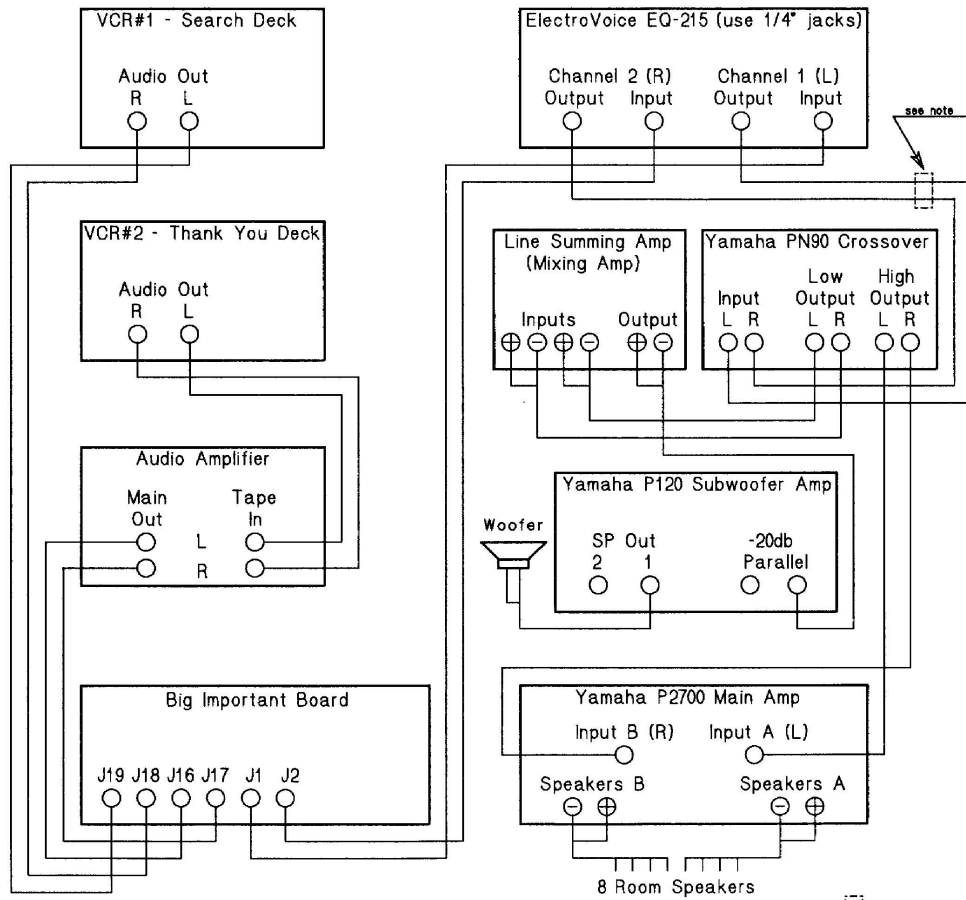

NOTE: If equipped, the SPL Computer goes in-line where indicated with

COMPUTER / WIRING DIAGRAMS

There isn't much else than can actually be "said" about the computer itself that hasn't already been outlined in the GENERAL DESCRIPTION section. The computer is an Apple II+ or IIE that has been modified to work with the custom-made cards (boards in the slots) manufactured by Creative Engineering, Inc.

On the following page is a wiring diagram that shows the connections between the computer cards (boards) and the other components of the show.

GENERAL NOTES:

- 1) Keep the Caps Lock on at all times.
- 2) Keep at least one foot clearance behind the rack that holds the computer (to prevent heat build-up).
- 3) Keeping the monitor screen clean will help the lightpen work efficiently.
- 4) Protect the disks and drive from dust, and, as usual, don't ever expose the floppy disk itself (protected by the sliding metal door on the plastic disk casing).
- 5) Keep the lid ON the computer at all times. Leaving the lid off is far too dangerous - anything falling into the interior of the computer could do serious damage.
- 6) The computer has its own internal power supply that should last a few years, depending on how long the computer is on each day. If you have to replace the power supply, use the spare in the spare parts kit and reorder another spare. Without the computer, the show will not run.

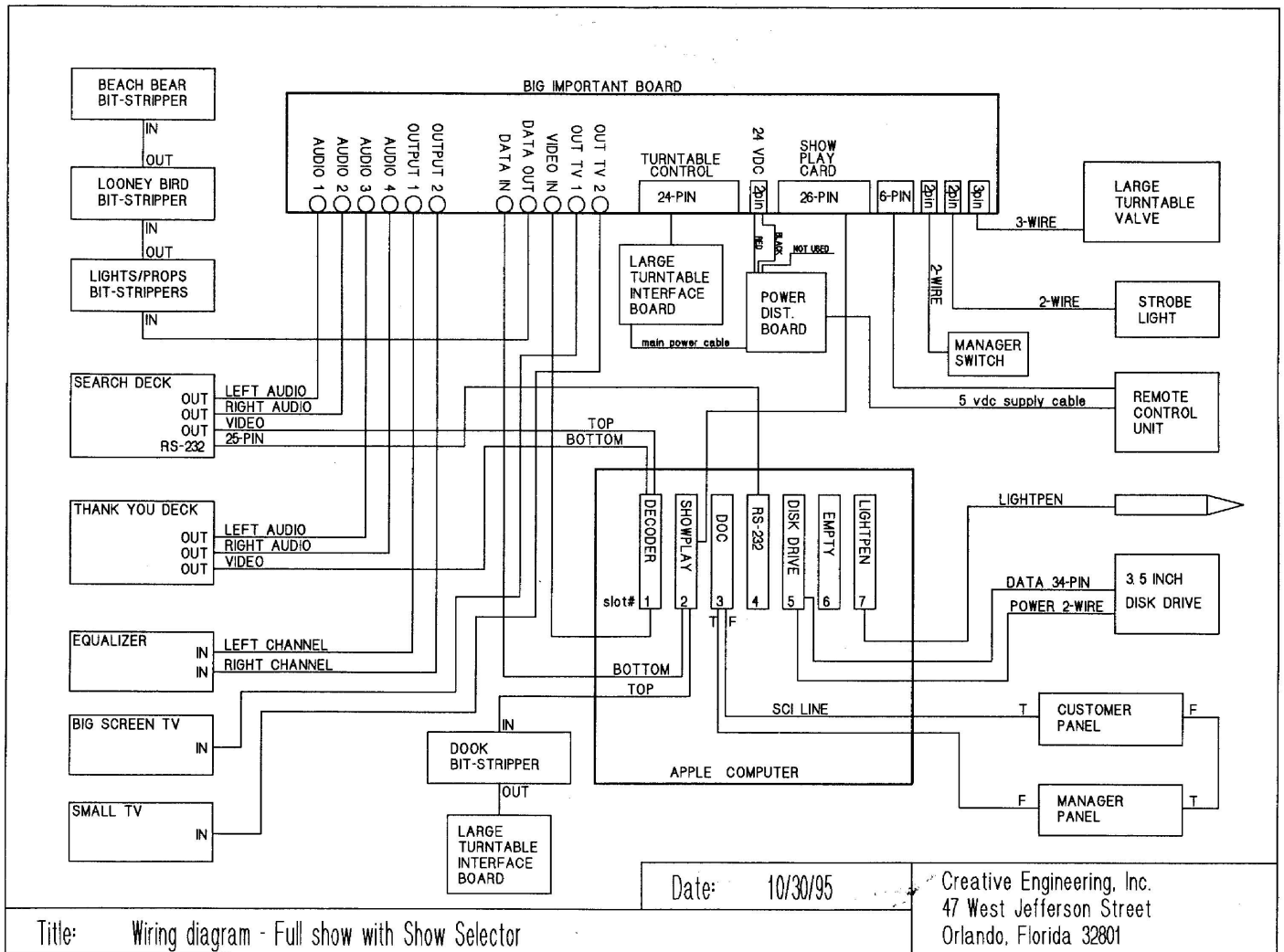

Date: 10/30/95

Creative Engineering, Inc.
 47 West Jefferson Street
 Orlando, Florida 32801

Title: Wiring diagram - Full show with Show Selector

BIG IMPORTANT BOARD

The Big Important Board (formerly known as the turntable board) is mounted on standoffs on a shelf in the audio rack, and is the most important (thus, the name) and most complex board in the entire system. The Big Important Board (BIB) and its connectors are shown in the diagram at the end of this section.

The BIB performs many functions, both on its own and in conjunction with the computer. These functions are:

- 1) Receives left and right audio channels from VCR(s) (jacks J19-J17), decides which is playing, and passes the audio out to the equalizer (jacks J1 & J2).
- 2) Collects show data from the computer's showplay card, sends it through the bit-stripper, and passes the signal on to the lights/props bit-strippers. The bit-stripper on the BIB strips out the showplay data necessary to control the large turntable, the three character turntables, and the strobe light.
- 3) Receives video signal from the computer's video decoder card, amplifies the signal, and sends it out to the large screen TV and Looney Bird TV (jacks J8-J10).

NOTE: For shows with Karaoke, jacks J8-J10 work differently. J8 receives the video signal, J10 receives the composite monitor signal from the computer, and J9 outputs whichever the BIB selects to the Karaoke TV.

- 4) Via the 24-pin connector, reads positioning information from the large turntable and character turntables, and controls the valves for the character turntable motors.

- 5) Operates the remote control for the commercial VCR.

NOTE: Your board may have an 8-pin connector for the remote instead of the original 6-pin as shown in diagrams. The other two pins supply the 5 volts that used to be picked up on the main power distribution board.

- 6) Receives Manager switch signal (if so equipped).
- 7) Controls the valve for the large turntable motor.

The power to the BIB is supplied by an independent power supply mounted on the same shelf and behind the BIB. There is a 6-pin jack on the BIB (J13) to accept the connector of the power supply. Looking at the BIB from behind the audio/control rack, the pin layout is shown in the diagram at the end of this section.

BIG IMPORTANT BOARD - STANDARD

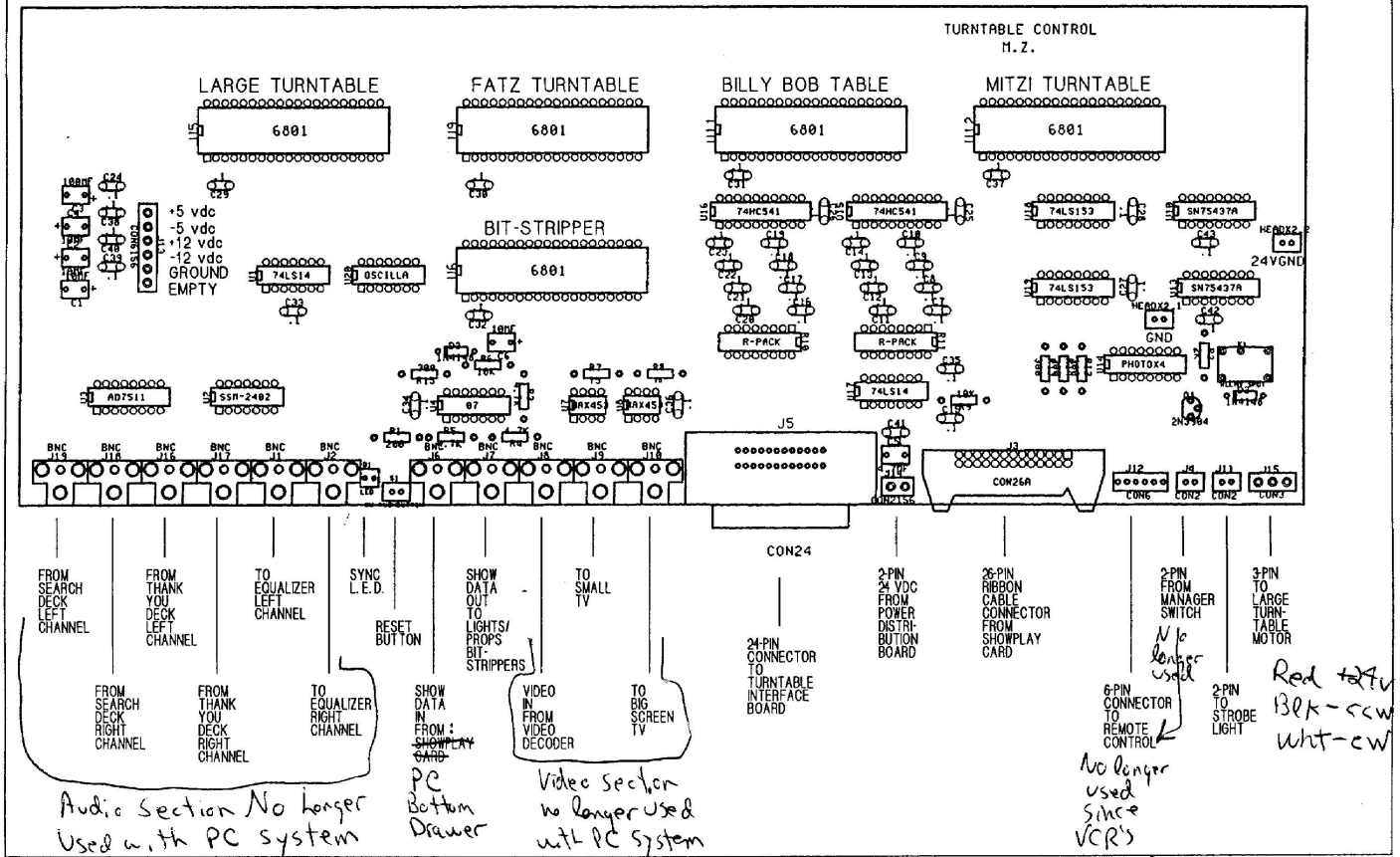

DC POWER SUPPLY CIRCUITS

There are two external power supplies used in the show, both mounted in the Audio/Control rack. The smaller power supply is directly behind the Big Important Board (BIB). Its sole purpose is to power the BIB. The larger main power supply, mounted on the bottom shelf behind the power distribution board, supplies all the other DC-powered components of the show.

NOTE: The BIB does get its 24vdc, used to control the large turntable motor valve, from the main power supply, via the power distribution board (see BIB section).

Both power supplies are designed specifically for the requirements of your show. Should one ever need to be replaced, you must replace it with an original from Creative Engineering to ensure proper operation and prevent damage to other components.

Included diagrams: BIB power supply
 Main Power Distribution
 Large Turntable Interface Board
 Limit Switch circuit

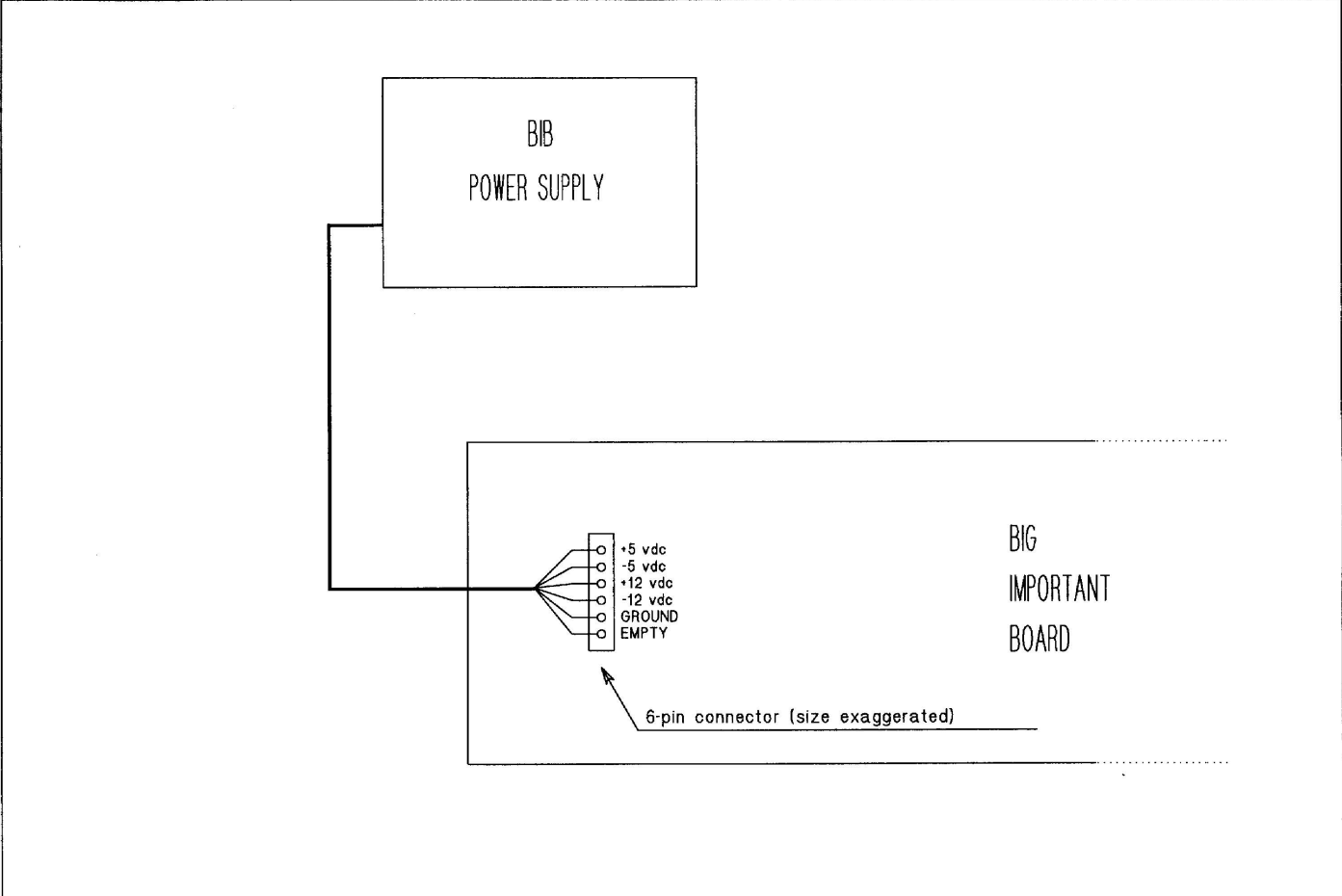

Title: BIB power supply		Tolerance (unless indicated):	Creative Engineering, Inc. 47 West Jefferson Street Orlando, Florida 32801
Date: 08/18/95	Scale: Representational		

- Wiring connections to this board are described, rather than illustrated, for the following reasons:
- 1) Jacks J1 and J9 are in parallel; therefore, connectors to them may be reversed.
 - 2) Jacks J2 through J8 are in parallel; therefore, connectors to all of them might be in any order.
 - 3) The ends of the cables are labeled to indicate their purpose.

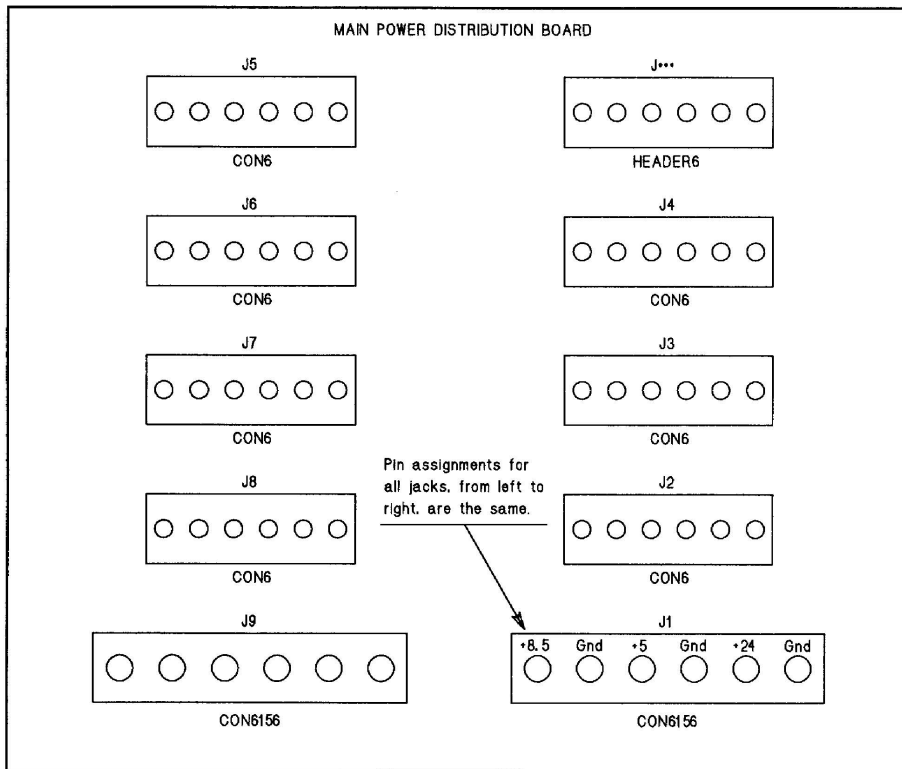

LARGE 6-PIN CABLES ON J1 AND J9

- One from main power supply
- One to Large Turntable Dist. Board

SMALL 6-PIN CABLES ON J2 THROUGH J8

- One cable each to:
- Dook bit-stripper
 - Beach Bear bit-stripper
 - Looney Bird bit-stripper
 - Lighting bit-stripper
 - Props bit-stripper

- One cable to the 2-pin (24vdc) jack on the Big Important Board

- **One cable to deliver 5vdc and ground to power the VCR remote control

- ** Newer shows will not have this cable. (The BIB's 6-pin jack to the remote is expanded to 8-pins to supply the needed 5vdc and ground)

Title: Main Power Distribution		Tolerance (unless indicated):	Creative Engineering, Inc. 47 West Jefferson Street Orlando, Florida 32801
Date: 08/18/95	Scale: Representational		

J1 : Receives the 24-pin cable that comes up through the main harness from the BIB.

J2 : Receives the 6-pin power cable that comes up through the main harness from the Power Distribution Board.

J6 through J9 : Female RCA jacks, connected in parallel. One serves as an input to receive the show data cable that comes up through the main harness. The other three are show data outputs to the bit-strippers of Billy Bob, Fatz, and Mitzi. The arrangement (order) of the four cables does not matter.

J3 : Power distribution cable to Mitzi bit-stripper

J4 : Power dist. cable to Billy Bob bit-stripper

J5 : Power distribution cable to Fatz bit-stripper

J10 : Control cable to Mitzi turntable valves

J11 : Control cable to Billy Bob turntable valves

J12 : Control cable to Fatz turntable valves

J13 : Power cable to center table upper IR board

J14 : Power cable to Fatz table upper IR board

J15 : Power to Billy Bob table upper IR board

J16 : Power cable to Mitzi table upper IR board

J17 : Receiver cable to Mitzi lower IR board

J18 : Receiver cable to BBob lower IR board

J19 : Receiver cable to Fatz lower IR board

J20 : Rec'vr cable to center table lower IR board

J21 : Power cable to limit switch

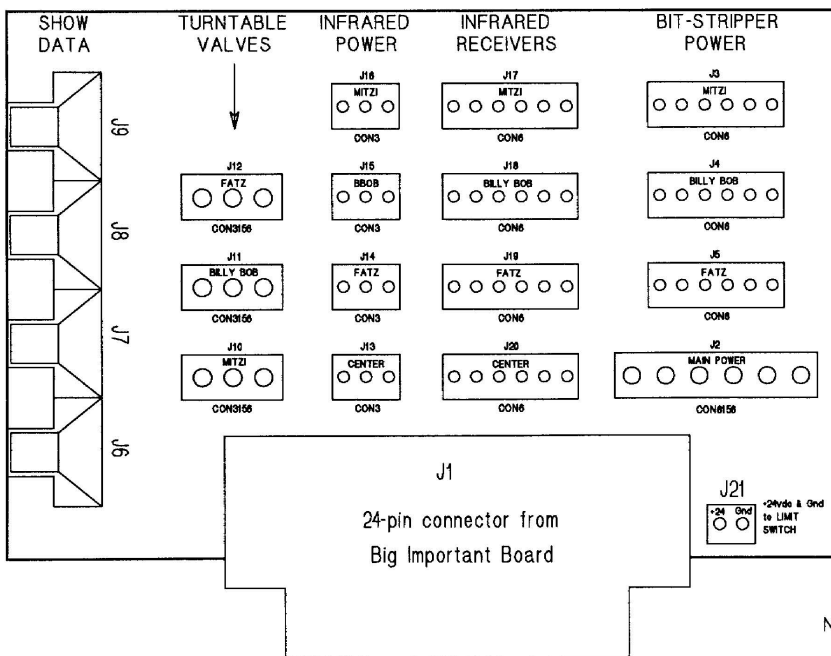

NOTE: This board is located on a cross brace of the center turntable between Billy Bob and Fatz.

Title: Large Turntable Interface Board	Tolerance (unless indicated):	Creative Engineering, Inc. 47 West Jefferson Street Orlando, Florida 32801
Date: 08/21/95		

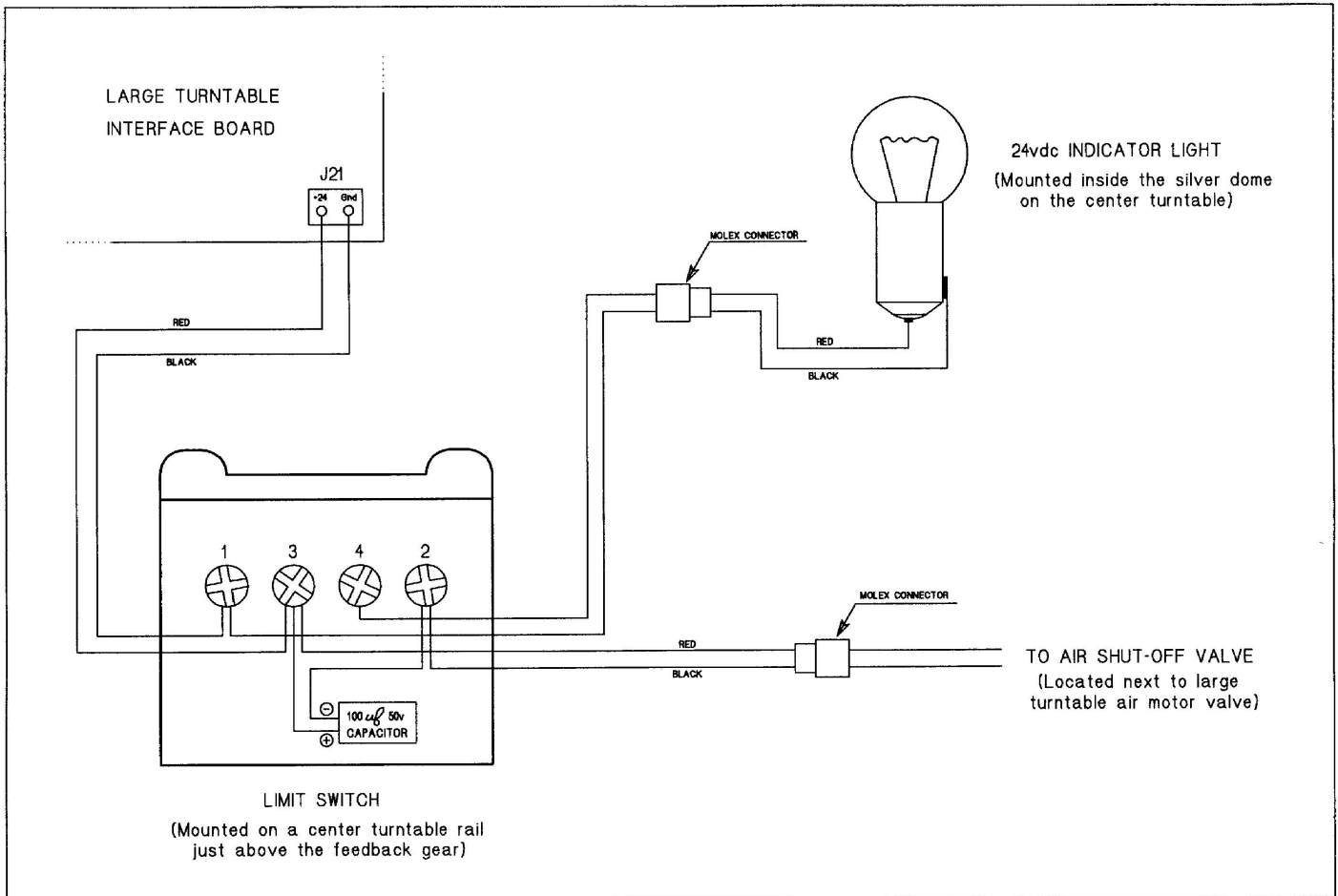

Title: Limit Switch circuit	Tolerance (unless indicated):	Creative Engineering, Inc. 47 West Jefferson Street Orlando, Florida 32801
Date: 08/22/95		

OPERATING SYSTEM

New text, detailing the various functions of the OPERATING SYSTEM programs, is under development.

OPERATING SYSTEM

The term "Operating System" stands for the collection of programs that control the show's operation during Show Selector Mode, and when manually running a show. These Operating System programs are on every disk provided by us with each new tape you receive. Each disk and tape are created and delivered as a set. They must be used together and, at the appropriate time, returned to us together. In other words, last month's disk will not work with this month's tape, or any other tape except the one that came with the disk.

The root of the system is the disk interface code that reads and writes to the disk. This code is written by us, and is not compatible with any other system's language or disk operating system (including the DOS typically used by an Apple computer). Therefore, the disks provided by us cannot be copied by you, as the format will not be recognized by any disk copying software.

Along with the programs on the disk is a key component of the system called the "index," which contains a variety of information that pertains to your tape and your show configuration. For shows with Show Selector, the index contains the show titles, which Selector panel buttons they are assigned, the exact VCR counter location of each show on the tape, the Manager Panel default timer setting, and the "timeout," which is the length of the break the system takes after every four shows.

Your tape and disk will already be "indexed" with all this information, and ready to run when you receive it. NOTE: There is a user function called *INDEX TAPE* that actually goes through the time-consuming process of playing back the entire tape and re-calibrating the locations of every show or song on the tape (more on this later), but under normal circumstances, you won't need to use it.

There are two types of screen displays used by the system: graphic "panels" and text screens. During most daily operations, you will only see panels which have a light-colored background and dark-colored words and borders. A border (box) and the words inside are, together, referred to as a "button." To select or "press" a button, put the lightpen to the screen within the button area, wait for the button's border to become bolder, then press the spacebar. There are many informational buttons that will react to the lightpen, but will do nothing when the spacebar is pressed. Only the buttons that are presented for your input can actually be "pressed." Text screens (light-colored letters on black background) are used for system errors in the Operating System, and in some of the functions covered in the next main section titled SHOW ADJUSTMENT UTILITIES.

This section is divided into the following subsections:

- Initial Setup
- Starting the System (and entering Show Selector Mode)
- Show Selector Customer Panel
- Show Selector Manager Panel
- Other Utilities
- SCI Line Trouble

The subsection title is noted in the footer of each page.

On most pages of Starting the System and Other Utilities, there will be a close facsimile of the panel, general information about the panel (if any), and a list of button choices with descriptions. You'll find that most of the panels are self-explanatory, and, with some practice, you won't need to reference this manual on a regular basis.

The Show Selector Panel subsections describe how to use the two Selector Panels themselves, and how they interact.

The last section, SCI Line Trouble, discusses what to do if data is not making the "loop" from the computer, through both Panels, and back to the computer.

Before starting your system, make sure that:

- 1) the caps lock key on the computer is down (turned on).
- 2) the disk is unlocked (the slide button on the back of the disk is covering the square hole).

Initial Setup

- 1) Search Deck (Panasonic AG-5700) - The following settings need to be checked just once (as long as no one changes them):

On the back of the unit

- AUTO REPEAT is OFF (middle position of the switch).
- SENSOR REC is OFF.
- MODE LOCK is OFF.
- S-VHS is ON.
- VIDEO is set to LINE.

On the front of the unit

- Hi-Fi LEVEL knobs are set to center (straight up).

(Turn the VCR on and insert the show tape for the next two settings.)

- Locate the MEMORY/SEARCH button. Pressing the button repeatedly, you'll notice the "M" and "S" indicators alternately displayed just to the left of the counter display. Keep pressing the button until both the "M" and "S" are off (not displayed). This will leave the *memory* and *search* modes turned off.
- Locate the AUDIO OUT SELECT button. Pressing it repeatedly, you'll notice the "L" and "R" indicators changing configuration. Keep pressing the button until the "L" and "R" are both on (displayed). This will leave the audio output select set to stereo (Hi-Fi).

- 2) Thank You Deck Mixer (Radio Shack SSM-50):

- If selectable, make sure output is set to stereo.
- The level of the Thank You Deck audio is controlled by the CD2 slide of this mixer. Try an initial setting of 7, and adjust accordingly.

Starting the System

This subsection describes the few easy steps necessary to start the system and automatically enter the Show Selector Mode. Also discussed are the Show Selector Mode panel itself and the Main Menu panel.

IMPORTANT! If you have just received a new disk and tape, make absolutely sure that you have removed the old tape and disk (and prepare them to be shipped back to us).

To proceed with Starting the System:

- 1) Turn on all circuit breakers for the show.
- 2) Turn on compressor system.
- 3) Turn on sound system from top down (EQ, then amps).
- 4) Make sure Selector Panels are both on.
- 5) Make sure the Panasonic VCR (Search Deck) is on and the appropriate tape is loaded.
- 6) Turn on RCA VCR (Thank You Deck) and make sure Thank You tape is loaded.
- 7) Insert appropriate disk in the drive.
- 8) Turn on computer monitor.
- 9) Turn on computer.

- 10) Turn to the next page.

66
03

Startup page for the
New RAE with Show Selector

First, make sure that all parts of the
system are turned on. This includes
the TAPE DECKS, SOUND SYSTEM, BIG
SCREEN TV, LOONEY'S MONITOR, AIR COM-
PRESSOR, SHOW SELECTOR PANELS, and any
other power to POWER SUPPLIES, etc.

Press RETURN when POWERED UP

--

66-03

INFO: This is the Startup panel. Follow the instructions. Make sure both VCR's are turned on and both tapes are loaded. Push the STOP button on the Thank You Deck (just to make sure it's stopped), and press the computer's RETURN key when you're ready.

ACTIVE BUTTONS: none

[Pressing RETURN will take you to the panel shown on page 3.]

66
04

Press here to start up the Show Selector system which will setup the tapes and turn on the Show Selector Panels.

Or press here to go to the MAIN MENU which allows you to use the Adjustment Utilities, or manually control the show, or Index Tapes, Clear Recent Plays, etc.

66-04

INFO: The system checks to see if your index is valid. If it is (and it always should be), you'll get the panel above. If there is no valid index, you'll be forced to create one (described later in the Other Utilities subsection).

ACTIVE BUTTONS: 2

[*the upper button*]: Always press this button if you are planning to go into Show Selector Mode. This button will go to the panel on page 4.

[*the lower button*]: Cancels Startup. This button will take you directly to the Main Menu panel shown on page 8.

IMPORTANT: If you press this button and cancel the Startup procedure, the VCR's will not be reset. If, when you get to the Main Menu, you choose to enter the Show Selector Mode, the tapes will not be properly re-zeroed, and the show will not operate properly. Only choose this button if you are planning on immediately using one of the other three buttons on the Main Menu.

60
10

Did you mean to start the
SHOW SELECTOR?

I will be tied up for 2-3
minutes rewinding tapes!

NO!
Get me
out!

YES...
Proceed

60-10

INFO: A chance to confirm your selection.

ACTIVE BUTTONS: 2

YES...Proceed: Proceeds with Startup, and goes to the panel on page 5.

NO! Get me Out!: Cancels Startup - Takes you directly to Other Utilities panel described in the Other Utilities subsection.
IMPORTANT: If you press this button and cancel the Startup procedure, the VCR's will not be reset. Only choose this button if you need to utilize one of the Other Utilities panel's functions before completing the Startup process. When you leave the Other Utilities panel, be sure to choose *SET UP VCR's* which will bring you back to this panel where you can then choose to proceed with the Startup procedure.

60
20

Please wait while the VCR tapes
are rewound, calibrated, and cued
up. This will take 2-3 minutes.

60-20

INFO: While this panel is displayed, the system (not you) will automatically:

- 1) Rewind the Search Deck.
- 2) Reset the Search Deck counter.
- 3) Rewind the Thank You Deck.
- 4) Wait until approximately 1 minute has passed from the time the Thank You Deck began rewinding. (The system does not know when the Thank You Deck is done rewinding, but it does know that, under any circumstances, it will take less than 1 minute.)
- 5) Play the Thank You Deck up to the first stop signal.
- 6) Stop the Thank You Deck. (The deck is now cued to the first Thank You show.)

ACTIVE BUTTONS: none

[After the Thank You Deck tape is cued (stopped at the proper location), the system will automatically go to the Show Select Mode panel shown on page 6.]

61
04

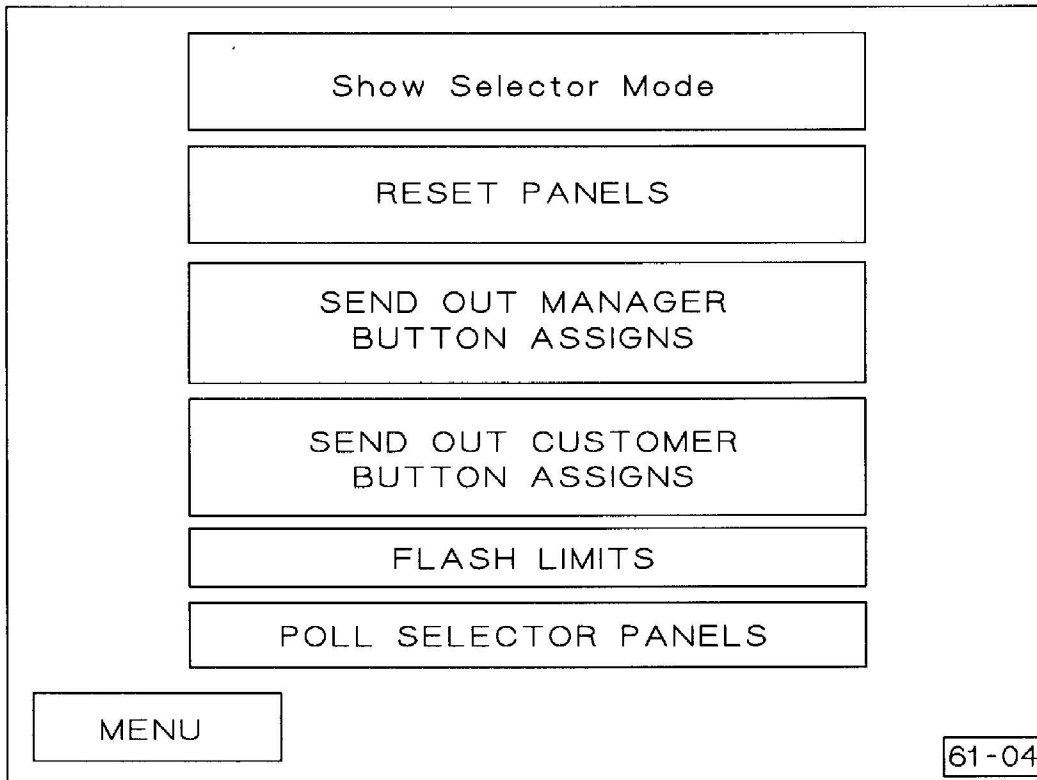

INFO: Most of the buttons on this panel are informational, and will appear on the panel one at a time as the following procedures takes place:

1) *RESET PANELS* - Quickly flashes all the buttons on both Selector panels, just once, to indicate that the Selector panels have been reset.

2) *SEND OUT MANAGER BUTTON ASSIGNS* - Makes all shows eligible for selection on the Manager Panel (all buttons lit).

3) *SEND OUT CUSTOMER BUTTON ASSIGNS* - If the Show Selector has been restarted, or if the computer has been turned off since the system was last in polling mode, this makes all shows eligible for selection on the Customer Panel (all buttons lit). Otherwise, if you came here directly from the Main Menu, the system will set the Selector panel buttons to where they were when you last left polling (recently played shows are ineligible and their buttons will not be lit).

4) *FLASH LIMITS* - n/a

5) *POLL SELECTOR PANELS* - When this button appears, the system is now in polling mode - waiting for an eligible button to be pushed on either panel. For more details, see the two Show Selector subsections.

IMPORTANT: If the panel on the screen suddenly disappears, and changes to a text screen, it means the system did not get a response from one of the Show Selector panels. For more information, see the subsection titled SCI Line Trouble.

ACTIVE BUTTONS: 1

MENU: Exits polling mode, and goes to Main Menu panel shown on page 8.

[Pressing the keyboard's Q key (for "Quit") will also exit polling mode.]

60
16

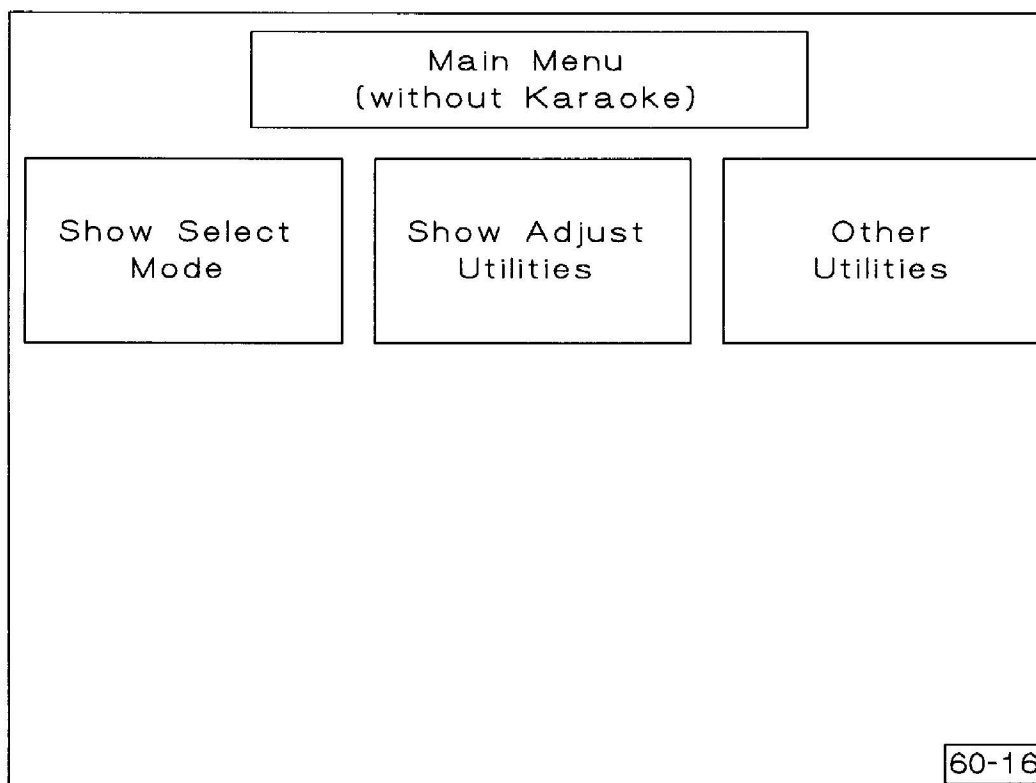

INFO: This is the Main Menu from which all functions of the system can be reached.

ACTIVE BUTTONS: 3

Show Select Mode: Goes directly to Show Select Mode panel shown on page 6 and enters polling mode. The recently played shows will remain ineligible (buttons not lit). If it is your intention to have all shows on the Customer Panel eligible for selection, do not use this button to start the Show Selector. Instead, go to the Other Utilities panel (described in the Other Utilities subsection) and choose the *RESTART SHOW SELECTOR* button.

Other Utilities: Goes directly to Other Utilities panel which is described in the Other Utilities subsection.

Show Adjust Utilities: Leaves the Operating System entirely, and utilizes the programs described in the next main section, SHOW ADJUSTMENT UTILITIES. NOTE: When you return to the Operating System from Show Adjustment Utilities, you will not come back to the Main Menu. Instead, the system will restart the Operating System at the Startup panel shown on page 2.

Show Selector Customer Panel

This subsection describes the function of the Show Selector Customer Panel as it relates to the Operating System.

When the system is in Show Selector mode, as described in the Starting the System subsection, the system is "polling" both Selector panels; hence, the term "polling mode." Polling mode means that the system is constantly checking with the Selector Panels to see if a button has been pressed. This subsection describes what happens when a button is pressed on the Customer Panel, and what happens afterwards.

The Customer Panel has its own onboard hardware and software which is responsible for lighting the buttons that are eligible for play, determining which button has been pressed, flashing the light on the pushed button, and telling the system (computer) which button has been pressed. The communication between the Customer Panel and the system takes place via the DOC card in the computer through the SCI lines (telephone-type cables).

When the system is first started (or restarted from the Utilities panel) and put into polling mode, the system informs the Customer Panel that all twelve songs are eligible for play. The Customer Panel is programmed to light the button of each eligible show; therefore, all twelve buttons should be lit.

[IMPORTANT: If you exit polling mode, the Customer Panel's buttons may remain lit, but the system will ignore any request to play a show - even if a button is flashing. The Customer Panel and its buttons will be reset when you re-enter polling mode.]

When you press a lit button, the Customer Panel's program turns off the lights in all the other buttons, and begins flashing the light of the button you pushed to indicate that the request is being processed by the Customer Panel. From this point forward, all subsequent button-pushes are ignored. The Customer Panel then informs the system which button has been pushed, which prompts the system to go to the panel shown on the next page.

61
06

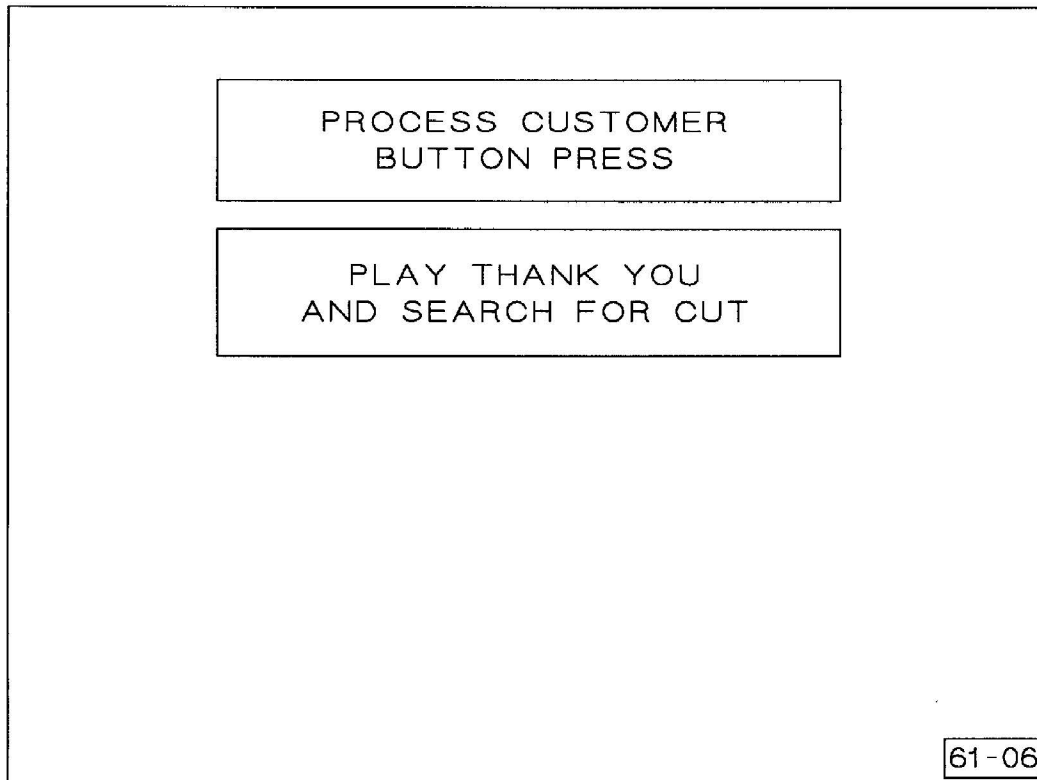

The top box on the panel indicates that the system is now processing the request. The Customer Panel told the system which button was pressed, and the system knows which shows are assigned to which buttons, so the system now knows which show to play.

The index (described earlier) contains the exact VCR counter location of each show on the Search Deck, so the system commands the Search deck to go to that specific location. Since the Search Deck is intelligent, it can locate and stop at that position by itself, without tying up the system (computer), i.e., the system does not have to monitor what the Search Deck is doing. Once the "go to" command is given to the Search Deck (which only takes a second), the system carries out its next duty which is to play a Thank You show. NOTE: When the Search Deck gets to the prescribed counter location, it doesn't actually "stop" the deck - what it really does is pause the tape, which is why the PLAY button on the Search Deck stays lit!

Next, like the second box on the panel notes, the system plays a Thank You show while the Search Deck is busy locating the requested show. At the end of the Thank You show, the system will read either a stop signal or a rewind signal on the Thank You tape.

Case 1) If it's a stop signal, the system simply stops the Thank You Deck, then automatically puts the Search Deck (already cued to the requested show) in play mode and plays the show.

Case 2) If it's a rewind signal, the system puts the Thank You Deck in rewind mode, then automatically puts the Search Deck in play mode and plays the requested show. [In this case, The Thank You Deck will be busy rewinding itself while the Search Deck is playing the show. Like all VCR's, the Thank You Deck will stop itself when the tape is fully rewound.]

NOTE: When the system commands the Search Deck to play the selected show, it also commands the Customer Panel to stop flashing the button light for the selected show. All of the Customer Panel's buttons are off while a show is playing.

At the end of the show, the system increments an internal counter (in memory) that determines whether or not it is time for the system to take a break. If the counter equals four, which is the preset number of show-plays between breaks, the system goes on break (see GOING ON BREAK on page xx). If the counter is less than four, the system will automatically return to polling mode as described below.

RETURNING TO POLLING MODE:

When the system automatically re-enters polling mode after a show (or after a break), the Customer Panel button for the show that just played will not be lit. That show is now ineligible for play, and will remain ineligible until five other shows have been selected from the Customer Panel. In order to prevent any one show from being played too often, the system maintains a list (in memory) of the five most recently played shows that were requested by the Customer Panel. Of course, if less than five shows have played since the system was started (or restarted from the Utilities panel), then only the shows that have played will be on the list, whether it's one, two, three, or four shows. When a show is ineligible for selection, the Customer Panel will not light the button, and pressing any button that is not lit will be ignored by the Customer Panel.

Example: Suppose the Customer Panel buttons are numbered 1 through 12 from left-to-right, starting with the first row.

<u>After this show is played..</u>	<u>these buttons will be lit.</u>
1	2,3,4,5,6,7,8,9,10,11,12
6	2,3,4,5,7,8,9,10,11,12
12	2,3,4,5,7,8,9,10,11
4	2,3,5,7,8,9,10,11
10	2,3,5,7,8,9,11
7	1,2,3,5,8,9,11
11	1,2,3,5,6,8,9
6	1,2,3,5,8,9,12
5	1,2,3,4,8,9,12

Notice that after the first five shows have played, there will always be five unlit buttons and seven lit buttons which are eligible for selection. The five most recently played shows are always excluded from the list of lit buttons.

There are several different functions of the system that will clear the list of the five most recently played shows after you exit polling mode. They are:

- 1) Rebooting the computer.
- 2) Playing a show selected from the Manager Panel.
- 3) Choosing *RESTART SHOW SELECTOR* on Other Utilities panel.
- 4) Choosing *CLEAR RECENT PLAYS* on Other Utilities panel.
- 5) Any other function that, afterwards, puts the Operating System back to the Startup panel, such as *Show Adjustment Utilities*.

Any time the list of the five most recently played shows is cleared, upon returning to polling mode, all twelve buttons should be lit as all twelve shows are again eligible for selection from the Customer Panel.

GOING ON BREAK:

As mentioned earlier, after every four shows selected from the Customer Panel, the system goes on break. The length of the break can be set by you (from the Other Utilities panel) to anywhere from 1 to 9 minutes. When the system decides it is time to go on break, the system will go to the panel on the next page.

(go to the next page)

61
11

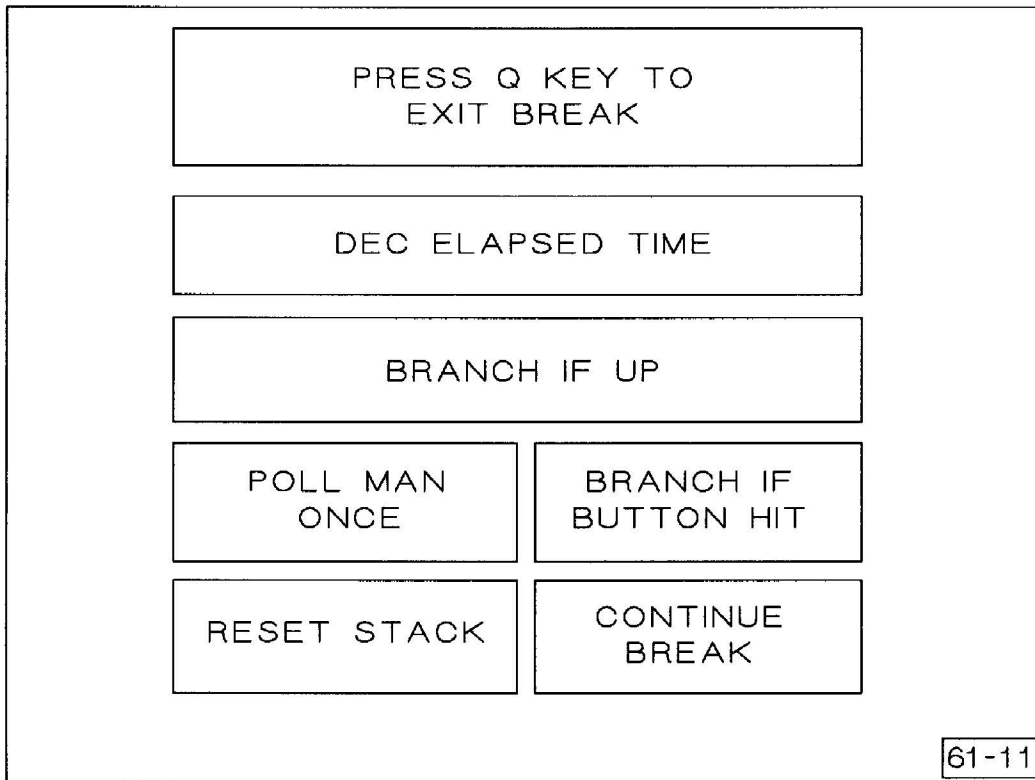

When this panel appears, it means the system is on break. The system immediately begins counting down the time left on the break. You can wait for the break time to elapse or, as the panel notes, you can interrupt the break by pressing the Q key at any time. In either case, the system will automatically return to polling mode. (The break has no effect on the list of recently played shows.)

The reason the break has a minimum setting of one minute is because the system uses the initial break time to rezero the Search Deck. The moment the system goes on break, it sends a command to the Search Deck to rewind the tape and then rezero the counter. This ensures that any slight inaccuracies in the counter due to fast-forwarding and rewinding will not accumulate and affect the search accuracy. If you press Q to exit the break before the Search Deck is fully rewound, the Search Deck will carry out the rewind and rezero commands anyway.

IMPORTANT: The Manager Panel takes priority over break time. This means that if the system is playing the fourth show of a set (and will consequently go on break when the show is over) when a button on the Manager Panel is pressed, the system will skip the break altogether and process the Manager Panel's request. However, the system will not skip the rewind/rezero command to the Search Deck. In this case, when the Customer's show is over, the system will acknowledge the Manager Panel's request, the Search Deck will rewind and rezero, then the Search deck will fast-forward to the show requested by the Manager Panel.

On the same subject, **be aware** that the system may decide to rewind and rezero the Search Deck at any time, even when it is not on break. Though you probably won't notice it happening, it is possible (through skipped breaks and such) for the Search Deck's counter to get a bit off. For this reason, the system, through its program, constantly monitors how close the Search Deck stops itself to the beginning of the show to which it is commanded to go. The system expects a certain amount of time to elapse between the command to play the Search Deck and reading show data from the tape. If the elapsed time is too much or too little, the system will, at its discretion, put everything else on hold for a few moments while it rewinds and rezeros the Search Deck.

Show Selector Manager Panel

This subsection describes the function of the Show Selector Manager Panel as it relates to the Operating System.

When the system is in Show Selector mode, as described in the Starting the System subsection, the system is "polling" both Selector panels; hence, the term "polling mode." Polling mode means that the system is constantly checking with the Selector Panels to see if a button has been pressed. This subsection describes what happens when a button is pressed on the Manager Panel, and what happens afterwards.

The Manager Panel has its own onboard hardware and software which is responsible for lighting the buttons, determining which button has been pressed, flashing the light on the pushed button, and telling the system (computer) which button has been pressed. The communication between the Manager Panel and the system takes place via the DOC card in the computer through the SCI lines (telephone-type cables).

Every time the system enters polling mode, the system informs the Manager Panel that all twelve songs are eligible for play; therefore, all twelve buttons should be lit. (Unlike the Customer Panel, all twelve songs are always eligible for selection on the Manager Panel.)

[IMPORTANT: If you exit polling mode, the Manager Panel's buttons may remain lit, but the system will ignore any request to play a show - even if a button is flashing. The Manager Panel and its buttons will be reset when you re-enter polling mode.]

A button on the Manager Panel can be pushed to request a show at any time, as long as the button is lit - even if the show is already running (or about to run) due to a selection made on the Customer Panel. When you press a lit button, the Manager Panel's program turns off the lights in all the other buttons, and begins flashing the light of the button you pushed (about once per second) to indicate that the request has been accepted. From this point forward, pushing any of the other buttons will be ignored by the Manager Panel.

If the show is not running (or about to run) due to a selection made on the Customer Panel, your Manager Panel request will be processed immediately.

If the show is already running (or about to run) when you press a Manager Panel button, the Manager Panel will "sit on" the request (with the button flashing) until the system has finished playing

the show requested by the Customer Panel. After the customer's show is finished running, the system will check with the Manager Panel to see if there is a request on hold. If there is, that request will then be processed immediately.

Once the Manager Panel request is acknowledged by the system, the Manager Panel informs the system which button has been pushed, which prompts the system to go to the panel shown on the next page.

(go to the next page)

61
07

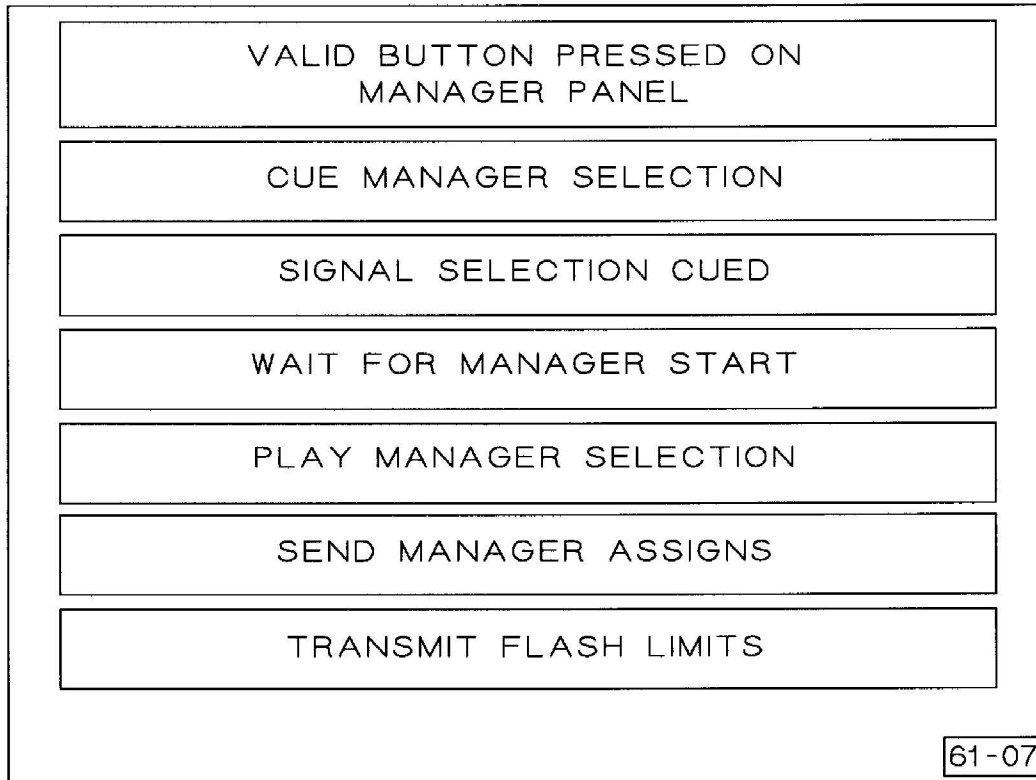

All of the buttons (boxes) on this panel are informational, and will appear on the panel one at a time as the following procedures takes place:

- 1) *VALID BUTTON PRESSED ON MANAGER PANEL* - Indicates that the system is now processing the request to play the show selected on the Manager Panel. All the button lights on the Customer Panel are now off.
- 2) *CUE MANAGER SELECTION* - The system has now commanded the Search Deck to go to the location of the selected show.
- 3) *SIGNAL SELECTION CUED* - The Search Deck has located the beginning of the show and is paused at that location. The system now commands the Manager Panel to double the flashing rate of the light (to about twice per second) in the button that was pressed to indicate that the show is cued and ready to play.
- 4) *WAIT FOR MANAGER START* - The system is waiting for you to press the flashing button on the Manager Panel again to actually start the show.
- 5) *PLAY MANAGER SELECTION* - When you do press the flashing button on the Manager Panel again, this box appears and the show begins to play. This box stays on the screen while the show plays.
- 6) *SEND MANAGER ASSIGNS* - After the show is over, this box indicates that the system is resetting the Manager Panel to relight all the buttons and make all shows eligible for selection again, once the system re-enters polling mode.
- 7) *TRANSMIT FLASH LIMITS* - n/a

The system now goes directly back into polling mode (as described in the Starting the System subsection), and makes all shows on both Selector Panels eligible for selection (all buttons lit).

IMPORTANT: If you wish to select another show from the Manager Panel to play right away, you must push the button on the Manager Panel before someone pushes a button on the Customer Panel!

NOTE: If you want to make changes in the arrangement of shows assigned to the Manager Panel buttons, that process is described in the Other Utilities subsection.

Other Utilities

This subsection describes the many choices of settings and functions selectable from the Other Utilities panel.

The most common way to access this panel is by choosing it from the Main Menu.

However, you can come directly to this panel during Starting the System if, when you are asked, "Did you mean to start the SHOW SELECTOR?", you push the button *NO! Get me out*. Remember, if you come to the Other Utilities panel in this manner, you will have skipped the process of setting up the VCR tapes. So, when you leave Other Utilities, choose *SET UP VCR'S* to continue the process where you left off.

The Other Utilities panel is on the next page, along with a brief description of each button, and the page number (if any) in this subsection where you can find more details of each button's function.

60
02

Other Utilities			
SET UP VCR'S	INDEX TAPE	TEST SCI LINE	RESET TESTS
LIST SONG TITLES	SAVE INDEX TO DISK	ASSIGN SONGS TO BUTTONS	KARAOKE SHOW COUNTS
RESTART SHOW SELECTOR	CONTINUE SHOW SELECTOR	CLEAR RECENT PLAYS	SET TIME OUTS
	PLAY SHOW DECK	PLAY THANK YOU DECK	MAIN MENU
CEI ONLY!			60-02

INFO: All of the functions of this panel are accessible by you, except the bottom button called *CEI ONLY!*

ACTIVE BUTTONS: 15

SET UP VCR's: Goes to the Startup procedure that (if you so choose) resets the tapes, cues the first Thank You show; clears the list of the five most recently played shows from memory, and automatically enters Show Selector Mode.

INDEX TAPE: Rewinds the Search Deck, resets the tape counter, and plays the entire tape (to the end of the last show on the tape) in order to build a new index of the locations of the stop signals and the rewind signal. Re-indexing a tape should only be done when absolutely necessary as it takes roughly 1 to 2 hours, depending on how many available shows are on your tape. See page 4.

TEST SCI LINE: Tests the SCI loop (the system of telephone-like cables between the computer's DOC card and the two Selector Panels) for continuity and communication protocol. See page 7.

RESET TESTS: Repeatedly restarts the program in the control chip of each Show Selector Panel which flashes all the buttons on both Selector Panels to indicate a successful reset. See page 8.

LIST SONG TITLES: Shows a list of all show songs on the tape, in the order they are recorded. The titles are often abbreviated. See page 9.

SAVE INDEX TO DISK: Writes the index (in memory) to the disk, replacing the index file currently on the disk, then automatically returns to the Other Utilities panel. This is a way to permanently save, for future sessions, any temporary changes you made today (since you last booted the computer).

ASSIGN SONGS TO BUTTONS: Allows you to assign any Show Selector song to any button on either Selector Panel. See page 10.

KARAOKE SHOW COUNTS: Reads from the disk and tells you the number of times each Karaoke song has been played since you received the disk/tape set. If you do not have Karaoke, the counts will all be zero. See page 18.

RESTART SHOW SELECTOR: Clears the list of the five most recently played shows from memory, and automatically enters Show Selector Mode with all shows eligible for play (all buttons lit).

CONTINUE SHOW SELECTOR: Retains the list of the five most recently played shows in memory, and automatically enters Show Selector Mode with as many as five shows ineligible for play (buttons not lit).

CLEAR RECENT PLAYS: Clears the list of the five most recently played shows from memory, and automatically returns to the Other Utilities panel.

SET TIME OUTS: Allows you to change the length of the break time (after every four shows) and/or change the length of time the system waits before automatically playing a cued show that was selected from the Manager Panel. See page 19.

PLAY SHOW DECK: Puts the Search Deck in play mode. The deck will play until it reaches a stop signal or rewind signal. See page 24.

PLAY THANK YOU DECK: Puts the Thank You Deck in play mode. The deck will play until it reaches a stop signal or rewind signal. See page 27.

MAIN MENU: Returns to the Main Menu.

CEI ONLY!: Do not press this button. If you accidentally do press this button, you will be prompted to enter a password that you do not know. Simply press the ENTER key and you will be returned to the Other Utilities panel.

61
12

<p>This page will play the show tape and build a table of the locations of the songs.</p>
<p>Insert a tape in the show VCR and press this button.</p>
<p>MENU</p>
<p>61-12</p>

INFO: This panel gives you a chance to confirm your choice to start the time-consuming process of indexing the tape. Since the tape is already indexed when you receive it, going through the process again can be referred to as re-indexing. This re-indexing process should only be done if you notice that one or more shows are not being cued at the right spot on the tape. The two examples of shows being miscued are:

- 1) The tape is cued a little too far back, and the tail end of the previously recorded show plays before the selected show plays.
- 2) The tape is cued a little too far forward, and the very beginning of the selected show is skipped.

Background: When a show is selected, the computer gets the counter number from the index that represents the spot on the tape where the show begins. The computer then commands the Search Deck to go directly to that counter number. From this point on, the computer is free to do other things, and the Search Deck (through its own software and hardware) handles the rest of the search. The Search Deck fast-forwards or rewinds until the tape is close to the target counter number. The deck then slows down, creeps toward the target number, and stops. The deck remains paused until it's time to play the show.

The counter device in the Search Deck is quite accurate, and the quality of the tape itself virtually prevents stretching; therefore, under normal circumstance, the counter numbers that

have been recorded as part of the index to indicate the beginning of each show will remain accurate. Though there is no predictable reason for needing to re-index the tape, the option to do so has been included for your use, just in case the counter numbers get a little off their marks.

Indexing requires you to wait while the system plays the show tape (at normal speed) from the beginning of the tape to the end of the last show. Depending on the number of shows and Karaoke songs on your tape, this procedure can take an hour or two (possibly longer). As the tape plays, the system builds a list of all the exact tape locations of the stop signals that are placed just before the beginning of each show (or Karaoke song) by recording the VCR's counter number when the stop signal is read. After the end of the last show on the tape, the system encounters a rewind signal, and records its location as well. After getting the rewind signal, the indexing is complete. The new table of stops and rewinds is automatically saved to the disk.

IMPORTANT: Once the indexing process begins, there is no way to cancel it via the keyboard or lightpen. If you wish to cancel the process midway, simply turn off the computer. Any new counter numbers memorized up until the time the computer is turned off are only in memory and are lost when the computer is turned off. The final table of locations is not saved to disk until the entire procedure is completed; therefore, until the new index is saved to disk, the original index on the disk remains intact.

ACTIVE BUTTONS: 2

Insert a tape...: This button proceeds with indexing the tape. Make sure the show tape is loaded in the Search Deck, and press this button. The system goes to the panel shown on the next page.

MENU: Cancels the indexing request, and takes you to back to the Other Utilities panel shown on page 2.

60
04

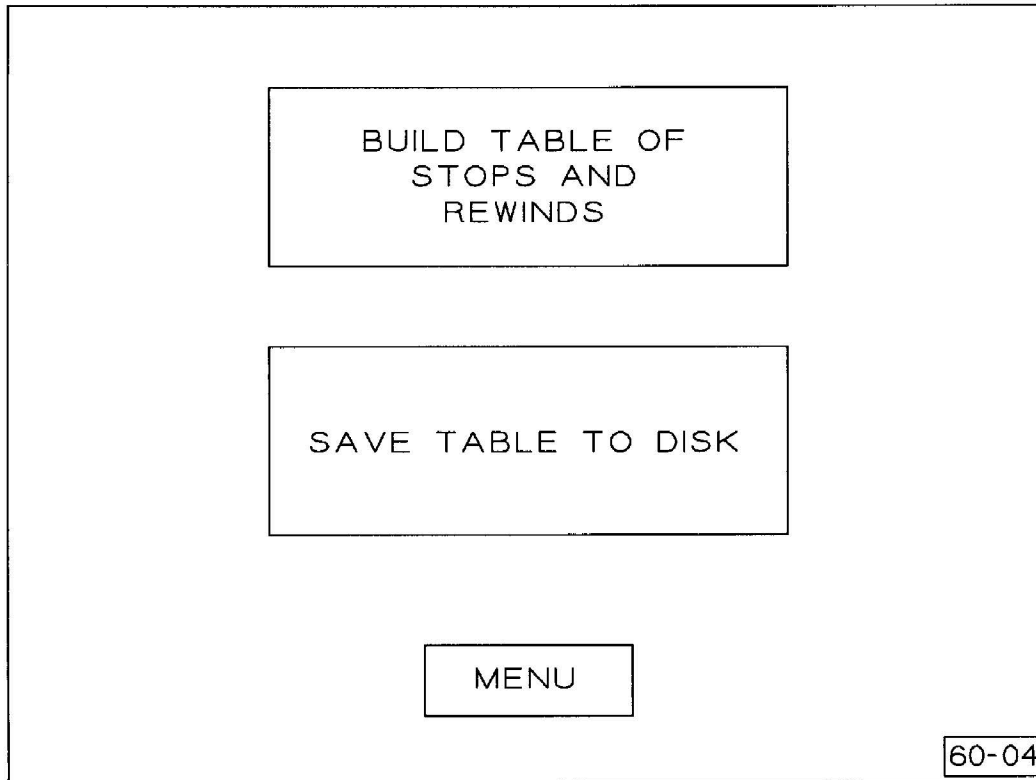

INFO: When this panel first appears, you will only see the upper informational button while the system automatically does the following:

- 1) Rewind the Search Deck.
- 2) Reset the Search deck's counter to zero.
- 3) Put the deck in play mode.
- 4) Play the entire tape and record the location of each stop signal and the rewind signal after the last show.
- 5) Stop the deck.
- 6) Place the *SAVE TABLE TO DISK* button on the screen to indicate that the new table of stops and rewind signal have just been written to the disk (replacing the old table).
- 7) Place the *MENU* button on the screen for your use.

ACTIVE BUTTONS: 1

MENU: Press this button to exit this panel. In order to reset the system after indexing, pressing this button takes you all the way back to the Startup panel.

SCI

```
-----XXXXXXXXX
A TEST OF THE SCI LINE REVEALS: XXXXXXXXX
SCI LINE TESTS OUT OK.

PRESS ANY KEY TO CONTINUE.
```

INFO: The picture above is an approximation of the text screen you will see when you press the *TEST SCI LINE* button. The purpose of the test is to send a test byte of data from the DOC Card in the computer, through the SCI cables (telephone-type cable) to the Manager Panel, then on to the Customer Panel, and back to the DOC Card. If the byte makes the loop intact, then the system knows that all of the SCI line cables are properly plugged in and the two Selector Panels are powered up. If the test is good, the screen above will include (as pictured) a line of text saying that the SCI LINE TESTS OUT OK.

If you get any other message besides one that indicates "OK," then the test has failed. If this is the case, turn to the SCI Line Trouble subsection for more information on what to do.

ACTIVE BUTTONS: none

[As noted on the screen, pressing any key will exit this screen and return you to where you were.]

RST
TST

Press Q to exit reset loop.

INFO: The purpose of this reset function is to test the onboard programming and hardware circuitry in both Show Selector Panels (Manager and Customer) simultaneously. During the test, which repeats itself every few seconds, the system (computer) signals the chips in the Selector Panels to restart their programs. When the program in each chip restarts, a hardware function of the panel turns all the button lights on, then the program very quickly turns them all back off again. Consequently, seeing all 24 buttons momentarily flash every few seconds is a visual confirmation that the reset tests are good. (This assumes that all 24 bulbs themselves are working.)

If the reset tests are not working, turn to the SCI Line Trouble subsection for more information on what to do.

ACTIVE BUTTONS: none

[As noted on the screen, pressing the Q key will exit the reset test loop and return you to where you were.]

60
07

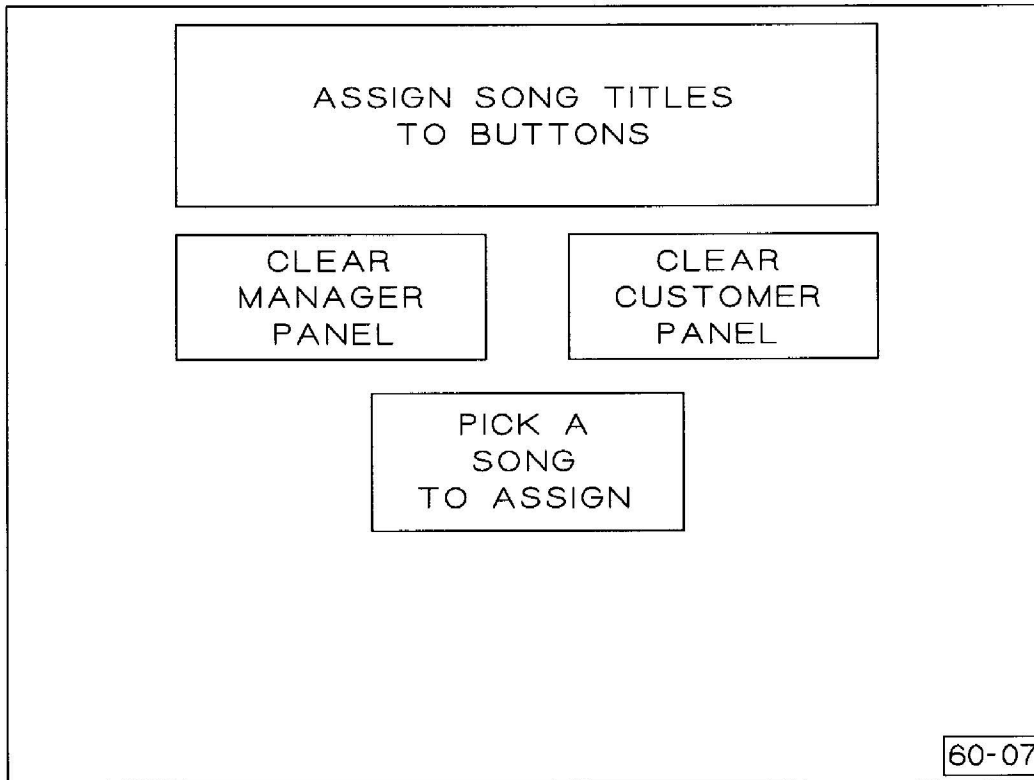

INFO: This function allows you to choose any show that has been recorded on the tape, and assign it to any button on either Selector Panel. If, by chance, you wish to start from scratch with either Selector Panel, you are also provided with buttons to clear an entire Selector Panel's group of assigned shows before assigning shows to the individual buttons.

ACTIVE BUTTONS: 3

PICK A SONG TO ASSIGN: Takes you directly to the list of available shows shown on page 12.

CLEAR MANAGER PANEL: This button erases (in memory) all show titles that are currently assigned to the buttons of the Manager Panel. There is no confirmation for this procedure, meaning, the procedure occurs without leaving the panel shown above. You will not see the results of having cleared the Manager Panel until you begin actually assigning shows to the Manager Panel. See NOTE below.

CLEAR CUSTOMER PANEL: This button erases (in memory) all show titles that are currently assigned to the buttons of the Customer Panel. There is no confirmation for this procedure, meaning, the procedure occurs without leaving the panel shown above. You will not see the results of having cleared the Customer Panel until you begin actually assigning shows to the Customer Panel. See NOTE below.

NOTE: If you change your mind after pushing the *CLEAR MANAGER PANEL* button and/or the *CLEAR CUSTOMER PANEL* button, fear not for the changes you just made are not yet permanent. If you wish to "undo" erasing the Panel(s), turn off the computer now.

Explanation: The button assignments are part of the "index" that is on the disk and loaded each time the system is started. Pushing either of these two buttons only clears the assignments from memory, i.e., the changes are not yet saved to disk. Rebooting the computer will reload the assignments from the current index on the disk.

60
13

ASSIGN SONGS TO BUTTONS	
SONG TO ASSIGN	
TITLE OF SONG	
PREPARE THIS ITEM TO GO IN INDIRECT LIST	
SELECT ONE	
MANAGER PANEL	CUSTOMER PANEL

60-13

INFO: This panel announces the title of the show that is to be assigned, and waits for you to choose which Selector Panel you wish to see to assign the show.

ACTIVE BUTTONS: 2

MANAGER PANEL: Takes you to the show title assignment panel that represents the Manager Panel buttons, shown on page 14.

CUSTOMER PANEL: Takes you to the show title assignment panel that represents the Customer Panel buttons, shown on page 16.

61
02

61-02	ASSIGN:	NEW TITLE	
IND	THIS IS THE MANAGER'S PANEL		
DONE			
CURRENT TITLE	CURRENT TITLE	CURRENT TITLE	CURRENT TITLE
CURRENT TITLE	CURRENT TITLE	CURRENT TITLE	CURRENT TITLE
CURRENT TITLE	CURRENT TITLE	CURRENT TITLE	CURRENT TITLE
GOTO CUSTOMER	SEE LIST	SAVE INDX	

INFO: There are two show title assignment panels. The twelve blocks of this panel on the monitor represent the twelve buttons of the Show Selector Manager Panel. To assign the show title you selected from the list (shown in the box at the top of the panel), simply point the lightpen to the block on the screen that represents the button of the Manager Panel to which you want to assign the show, and press the spacebar. From now until the time you shut off the computer, that new title will remain assigned to whichever Selector Panel button you chose. If you want the change(s) you made to be remembered for future sessions, you must push the *SAVE INDEX* button (either on this panel or on the Other Utilities panel) before the next time the computer is shut off, in order to write the changes to the index on the disk.

ACTIVE BUTTONS: 4

SEE LIST: Takes you back to the show title (song) list to pick another show to assign to a button. You can assign any number of songs as many times as you like. Remember to *SAVE INDEX* when you're done assigning shows if you want to save the changes to disk.

GO TO CUSTOMER: Switches to the Customer Panel assignment panel shown on page 16. The system remembers the selected show title for assignment when you switch from one assignment panel to the other.

SAVE INDEX: Saves the change(s) you made to disk for future sessions. (Button assignments are part of the "index" data that is always on the disk.) If you don't save the index to disk, the assignments you made will remain assigned only as long as the computer is left on.

DONE: Concludes the button assignment process, and returns to the Other Utilities panel.

61
03

61-03	ASSIGN:	NEW TITLE	
IND	THIS IS THE CUSTOMER'S PANEL		
DONE			
CURRENT TITLE	CURRENT TITLE	CURRENT TITLE	CURRENT TITLE
CURRENT TITLE	CURRENT TITLE	CURRENT TITLE	CURRENT TITLE
CURRENT TITLE	CURRENT TITLE	CURRENT TITLE	CURRENT TITLE
GO TO MANAGER	SEE LIST	SAVE INDX	

INFO: There are two show title assignment panels. The twelve blocks of this panel on the monitor represent the twelve buttons of the Show Selector Customer Panel. To assign the show title you selected from the list (shown in the box at the top of the panel), simply point the lightpen to the block on the screen that represents the button of the Customer Panel to which you want to assign the show, and press the spacebar. From now until the time you shut off the computer, that new title will remain assigned to whichever Selector Panel button you chose. If you want the change(s) you made to be remembered for future sessions, you must push the *SAVE INDEX* button (either on this panel or on the Other Utilities panel) before the next time the computer is shut off, in order to write the changes to the index on the disk.

ACTIVE BUTTONS: 4

SEE LIST: Takes you back to the show title (song) list to pick another show to assign to a button. You can assign any number of songs as many times as you like. Remember to *SAVE INDEX* when you're done assigning shows if you want to save the changes to disk.

GO TO MANAGER: Switches to the Manager Panel assignment panel shown on page 14. The system remembers the selected show title for assignment when you switch from one assignment panel to the other.

SAVE INDEX: Saves the change(s) you made to disk for future sessions. (Button assignments are part of the "index" data that is always on the disk.) If you don't save the index to disk, the assignments you made will remain assigned only as long as the computer is left on.

DONE: Concludes the button assignment process, and returns to the Other Utilities panel.

62
17

DISPLAY KARAOKE SHOW COUNT			
TIMES EACH CUT HAS PLAYED			
1	4	11	16
2	12	12	9
3	8	13	22
4	21	14	7
5	9	15	0
6	12	16	0
7	16	17	0
8	9	18	0
9	22	19	0
10	7	20	0

MENU

62-17

INFO: The numbers in the two left-hand columns (1 through 20) represent the Karaoke songs in the order they appear on the two panels that list the Karaoke songs for selection when Karaoke is running. The numbers in the two right-hand columns are the number of times each song was played since you received the tape/disk from us. Not all tapes have 20 selections. If your show is not equipped with Karaoke, the show counts will all be zero.

ACTIVE BUTTONS: 1

MENU: Returns to the Utilities panel.

62
13

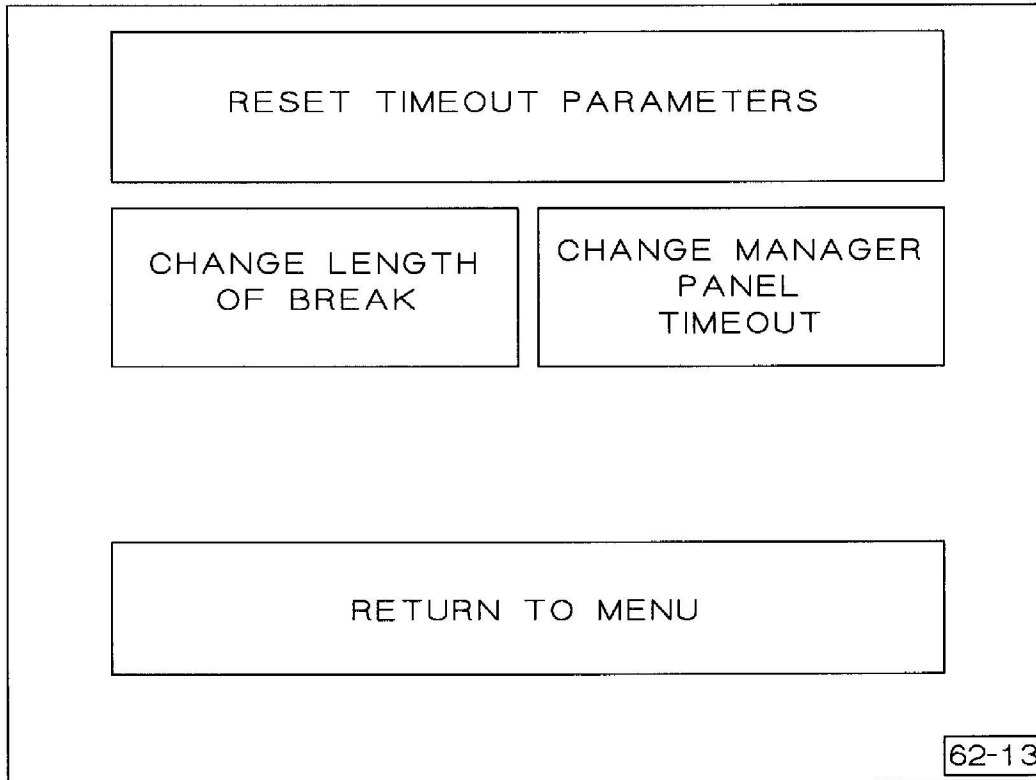

INFO: There are two different timeouts that can be set: the length of break that the system takes after every four shows, and the amount of time the system waits before automatically playing a cued show that was requested by the Manager Panel.

ACTIVE BUTTONS: 3

CHANGE LENGTH OF BREAK: Goes to the break-length selection panel shown on page 20.

CHANGE MANAGER PANEL TIMEOUT: Goes to the Manager Panel default-timer selection panel shown on page 22.

RETURN TO MENU: Returns to the Other Utilities panel.

62
02

HOW LONG DO YOU WANT THE BREAK?					NOW SET TO:			
					4	MINUTES		
1	2	3	4	5	6	7	8	9
								62-02

INFO: The Operating System is permanently programmed to take a break after every four shows selected by the Show Selector Customer Panel. The length of the break can be set from one to nine minutes. The panel shown above indicates the current length of time that the break is currently set to, and requires you to pick a new length for the break. Point the lightpen to the block with the number of minutes you desire, and press the spacebar. The length of the break is now set to the number of minutes you chose.

ACTIVE BUTTONS: none

[When you select a block and press the spacebar, the system automatically goes to the panel shown on the next page.]

62
04

SET BREAK TIME

Press this button if you want to save this change to disk for future sessions.

Press this button to return to menu.

62-04

INFO: When you select a new break-length time, it is set in the computer's memory, but not saved to the disk. The new break length will remain active until the computer is turned off. If, on the other hand, you want the new break length to apply to future sessions, you must save the setting to the disk, for which a button has been provided on this panel.

ACTIVE BUTTONS: 2

Press this button...to save this change...: This button will save the new setting to the disk (the appearance of the panel on the screen will not change while the disk is accessed). NOTE: The break-length setting is yet another variable that is part of the index file. What this button actually does is save the entire index to disk. Keep in mind that if you change the length of break now and don't save the change via this panel, but save the index later on through some other procedure, the break-length setting will be saved then!

Press this button to return to menu: Returns to the Other Utilities panel (whether or not the setting has been saved).

62
03

MANAGER BUTTON PRESS DEFAULT TIMER				
This is used to prevent a button from flashing forever on the Manager Panel if no button is pressed.				
NOW SET TO:	10	MINUTES		
You can change it to:				
1	6	8	10	MINUTES
				62-03

INFO: When a show is requested by the Manager Panel, and the show is located and cued on the Search Deck, the Manager Panel button begins flashing twice as fast while waiting for the button to be pushed a second time to actually start the show. If the button is not pressed a second time, the system relies on a default timer that, after a certain number of minutes, will automatically play the show (otherwise, the system could wait forever). The length of the default timer can be set to 1, 6, 8, or 10 minutes. The panel shown above indicates the current length of the default timer, and requires you to pick a new length for the timer. Point the lightpen to the block with the number of minutes you desire, and press the spacebar. The length of the default timer is now set to the number of minutes you chose.

ACTIVE BUTTONS: none

[When you select a block and press the spacebar, the system automatically goes to the panel shown on the next page.]

62
05

SET MANAGER DEADLINE

Press here to save this
change to the disk for
future sessions.

Press here to return to
menu.

62-05

INFO: When you select a new default timer length, it is set in the computer's memory, but not saved to the disk. The new default timer length will remain active until the computer is turned off. If, on the other hand, you want the new default timer length to apply to future sessions, you must save the setting to the disk, for which a button has been provided on this panel.

ACTIVE BUTTONS: 2

Press here to save this change...: This button will save the new setting to the disk (the appearance of the panel on the screen will not change while the disk is accessed). NOTE: The default timer length setting is yet another variable that is part of the index file. What this button actually does is save the entire index to disk. Keep in mind that if you change the length of default timer now and don't save the change via this panel, but save the index later on through some other procedure, the default timer setting will be saved then!

Press here to return to menu: Returns to the Other Utilities panel (whether or not the setting has been saved).

62
20

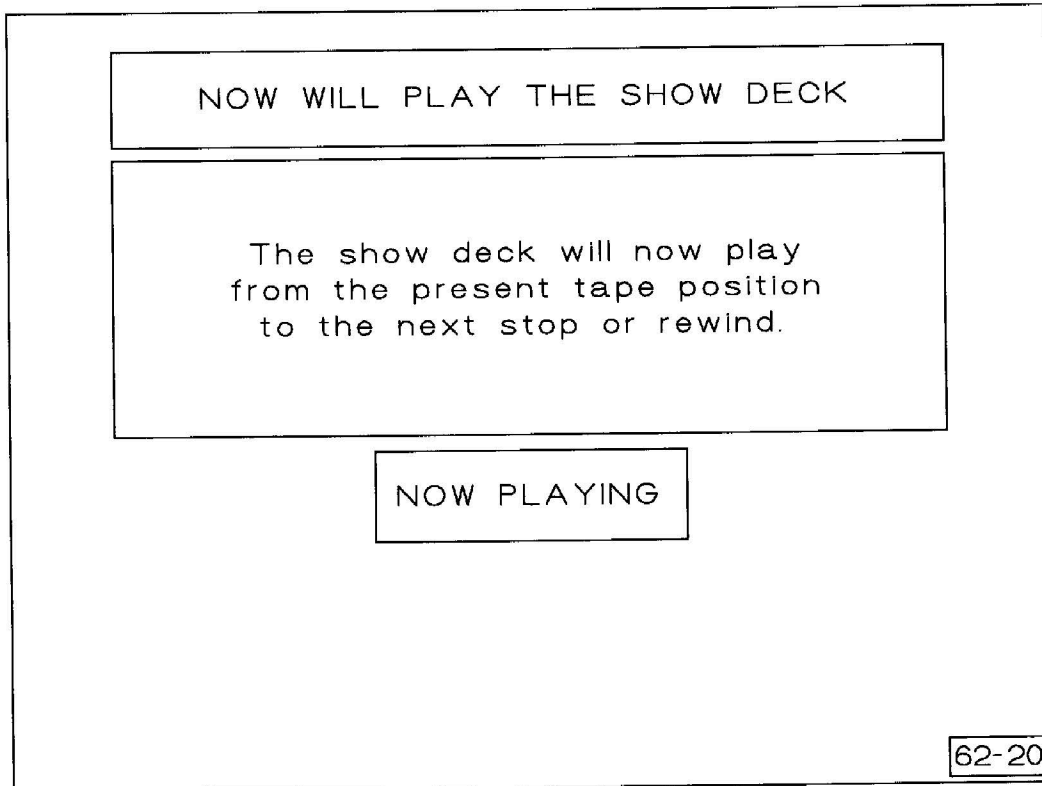

INFO: When you request the system to play the Show Deck (Search Deck), the panel above will appear, and the Show tape will begin to play. As noted on the panel, the system merely puts the Search Deck in play mode which plays the tape starting at whatever position the tape was left in. Normally - unless the tape has not been setup properly, you had a power failure, or due to some other intervention on your part - the system will always stop the tape between the end of one show and the beginning of the next; therefore, when you select this option, the system will begin playing a show from its beginning, and continue playing until the end of the show where the system reads the stop signal which stops the VCR. (The panel above remains on the screen while the show is playing.) If the system encounters a rewind signal instead of a stop signal, the system will know that it has just played the last show on the tape, and will automatically rewind back to the beginning of that show.

ACTIVE BUTTONS: none

[When the VCR is stopped after the show is finished (or after rewinding a bit), you will automatically be taken the panel on the next page.]

62
21

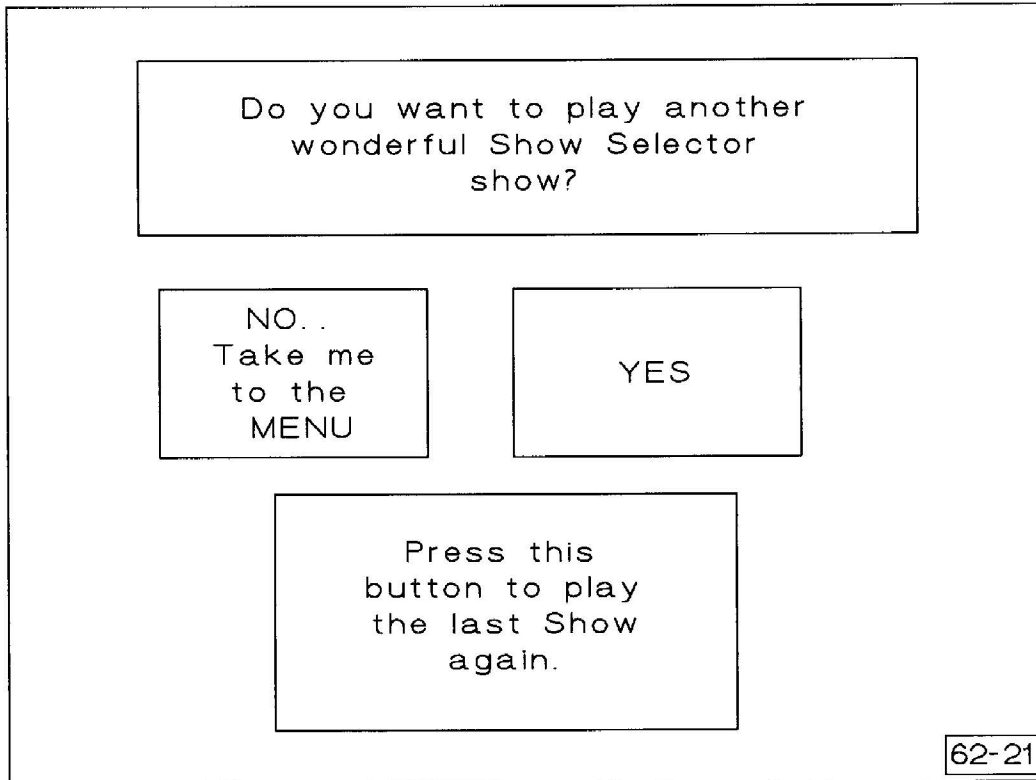

INFO: At this panel, you are asked if you want to play another show on the tape (or replay the show that just played, or quit playing the Show tape).

ACTIVE BUTTONS: 3

NO..Take me to the MENU: Returns to the Other Utilities panel.

YES: Plays the next show on the tape, and goes to the panel on the previous page, again, while playing the show.

Press this button to play the last show again: Goes to the panel on the next page to rewind the tape to the beginning of the show that just played.

66
06

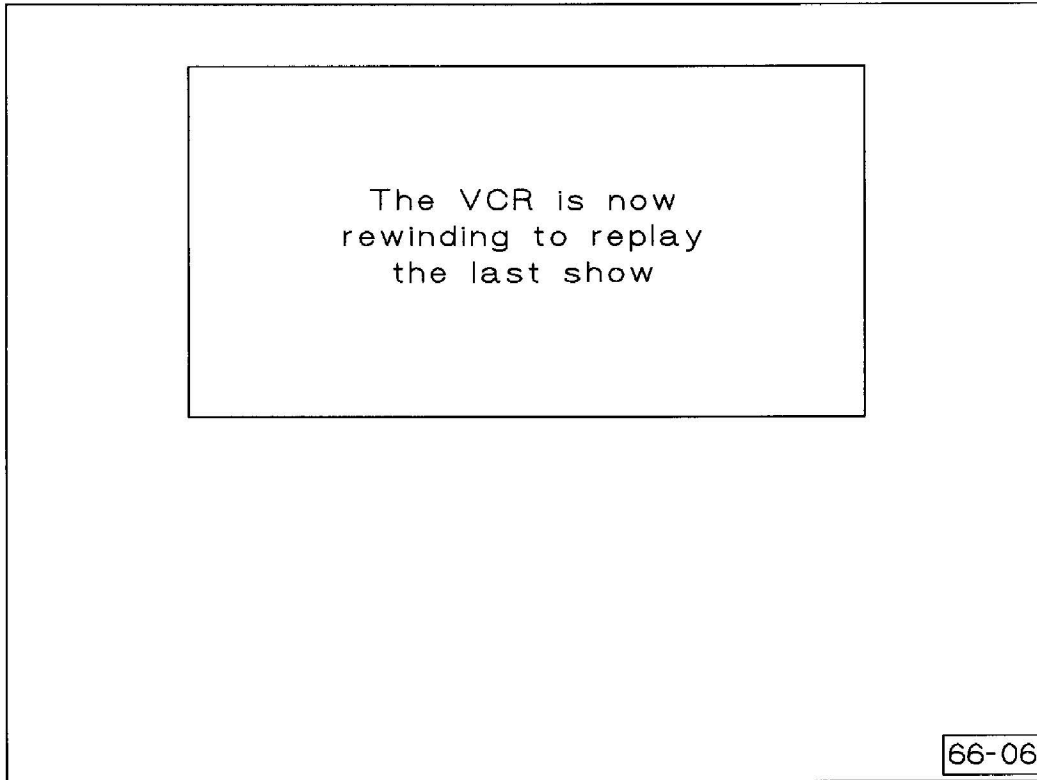

INFO: This panel is displayed to indicate that your request to replay the last show is being processed. The system has commanded the Search Deck to rewind back to the beginning of the last show. The system will then automatically go to the panel show on page 24, again, and play the show.

ACTIVE BUTTONS: none

62
22



INFO: When you request the system to play the Thank You Deck, the panel above will appear, and the Thank You tape will begin to play. The system merely puts the Thank You Deck in play mode which plays the tape starting at whatever position the tape was left in (normally cued at the beginning of a Thank You show). The tape will continue playing until the system reads a stop signal, located just before the beginning of the next show, which stops the VCR. The panel above remains on the screen while the tape is playing.

NOTE: The information in the center box means that if the system encounters a rewind signal instead of a stop signal, the system will know that it has just played the last Thank You show on the tape. The system will then automatically:

- 1) Rewind the Thank You tape back to the beginning.
- 2) Wait until approximately 1 minute has passed from the time the Thank You Deck began rewinding. (The system does not know when the Thank You Deck is done rewinding, but it does know that, under any circumstances, it will take less than 1 minute.)
- 3) Play the Thank You Deck up to the first stop signal.
- 4) Stop the Thank You Deck (now cued to the first show.)

ACTIVE BUTTONS: none

[When the VCR is stopped after the show (or after rewinding and cuing the first show), you will automatically be taken the panel on the next page.]

62
23

Do you want to play another
wonderful THANK YOU SHOW?

NO..
Take me
to the
MENU

YES

62-23

INFO: At this panel, you are asked if you want to play another show on the tape (or quit playing the Thank You tape).

ACTIVE BUTTONS: 2

NO..Take me to the MENU: Returns to the Other Utilities panel.

YES: Plays the next show on the tape, and goes to the panel on the previous page, again, while playing the show.

SCI Line Trouble

If the Operating System loses contact with either of the two Selector Panels at any time, the Show Selectors will not work, and the system will halt upon entering polling mode.

If the system presents you with a text screen (light colored text on black background) that resembles one of the two examples shown in this subsection, you will need to determine the nature of the problem based on what the text screen says.

(go to the next page)

SCI
BAD

```
-----XXXXXXXXX
A TEST OF THE SCI LINE REVEALS: XXXXXXXXX
NO BYTES MADE THE LOOP
SCI LINE NEEDS CHECKING
6801 CARD IN MASTER?
NURDS HAVE POWER?
-----
IF ANY NURD LOST POWER, NEED SYSTEM RESET
-----

PRESS ANY KEY TO CONTINUE.
```

If the screen contains the phrase "NO BYTES MADE THE LOOP," it means that the SCI Line circuit has been broken. The loop is made up of the DOC card in the computer, the Manager Panel, the Customer Panel, and the SCI Lines that interconnect them. Any of the following situations will break the loop:

- 1) Turning the Manager Panel off.
- 2) Unplugging the Customer Panel.
- 3) Disconnecting any SCI Line from any jack.
- 4) Crushed, pinched, or otherwise damaged SCI Line.
- 5) Malfunctioning power supply in either Selector Panel.

Make sure the Selector Panels are powered up and look for any disconnected or damaged SCI Lines. If everything checks to this point, press the space bar to exit the text screen.

If the system was in polling mode when the trouble occurred, the system will (upon pressing the spacebar) re-enter polling mode again. If the trouble is still present, the system will halt the polling mode and display the text screen again.

If you initiated testing the SCI Line from the Other Utilities panel, the system will (upon pressing the spacebar) return to the Other Utilities panel.

As long as the trouble persists, the system will not stay in polling mode, and continue to display the text screen saying that no bytes made the loop.

If the SCI Lines have been disconnected for some reason, they must be reconnected in the exact same arrangement as before. The SCI Line loop uses one-way communication, meaning, they cannot be reversed where they connect to the DOC card and both Selector Panels. As noted in the wiring diagram of this manual, each cable-end marked "TO" must connect to a cable-end marked "FROM." Any other combination will not work. Use the wiring diagram to check the layout of the loop, if necessary.

NOTE: Wherever two SCI Lines are joined together by a double female-ended coupler, another way to insure that they are properly connected is to look (through the clear connector-ends of the cables) at the colors of the individual wires. See the diagram on the last page of this subsection.

SCI
ERR

-----XXXXXXXXXX
A TEST OF THE SCI LINE REVEALS: XXXXXXXXX

ERROR: MESSAGE NOT IN
XMIT. STAT. REQ. MAN. NURD

PRESS ANY KEY TO CONTINUE.

If the screen contains the word "ERROR:," it means that one of the Selector Panels is not responding to the system. If you get any ERROR message, follow the same suggestions covered on the last two pages. If you continue to get the ERROR message, write down exactly what the screen says, and call Creative Engineering for assistance. (The message shown on the screen pictured above is just an example.)

CBL
END

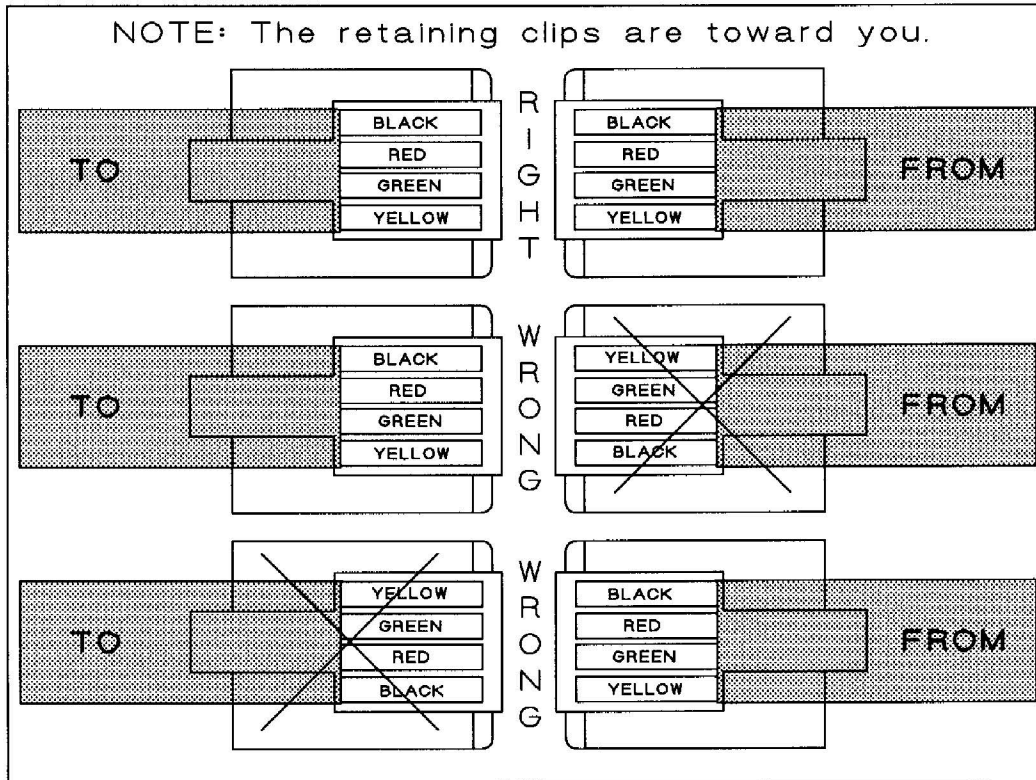

The example at the top of the diagram above shows the RIGHT way for the wires to be crimped into the ends of SCI Line cables where they come together at a coupler.

If you need to replace a damaged SCI Line cable, a telephone extension cable purchased from a hardware store MAY work. First, the cable must be for a two-line telephone, which will contain all four wires instead of just the center two. Second, be aware that companies that make the telephone extension cables are not concerned with which way the cable is turned when it's inserted and crimped into the plug-end. For telephones, it doesn't matter; but for our use, it does matter. You must be able to face the ends of the cable toward each other with the colored wires in the proper order in both ends, as shown in the top (RIGHT) example of the diagram above. Any other combination will not work. If the extension cable is RIGHT, label the ends "TO" and "FROM" according to the diagram.

If you are planning to make your own SCI Line cable, make absolutely sure that the plug-ends are attached in the arrangement shown in the top (RIGHT) example of the diagram above, and that the ends are labeled correctly. Also, after the ends are crimped, check the continuity of each wire in the cable.

IF YOU ORDER a new cable from us, it will be made to the length you need, wired correctly, and tested before it's shipped to you.

SHOW ADJUSTMENT UTILITIES

The SHOW ADJUSTMENT UTILITIES are diagnostic programs that are on the disk that comes with the show, but run (basically) separate from the Operating System programs. Consequently, when you exit Show Adjustment Utilities, the system will return to the Operating System's Startup panel to re-initialize everything, just as if you had just turned the computer on.

The two main purposes of the Show Adjustment Utilities are to help you properly adjust the speed of pneumatic movements, and to check the speed and positioning of the large turntable and character turntables. However, you can also manually operate any character servo, prop, or light included with your show.

IMPORTANT: See the MAINTENANCE section of the manual for guidelines on when to use certain functions of the Show Adjustment Utilities to keep your show in top-running condition!

This section is divided into the following subsections. The first five are related to the functions chosen from the main menu panel of the Show Adjustment Utilities (which is shown on the next page):

- 1) Adjust Movements
- 2) Adjust Turntables
- 3) Position Characters In Front
- 4) Read Turntable L.E.D.'s
- 5) Cycle And Time Tables

- 6) Turntable Positioning Exercise: A series of steps to help familiarize you with the character turntable positions. This subsection also describes, in detail, the infrared positioning numbers that are displayed when you choose the *Read Turntable L.E.D.'s* button on the main menu.

(go to the next page)

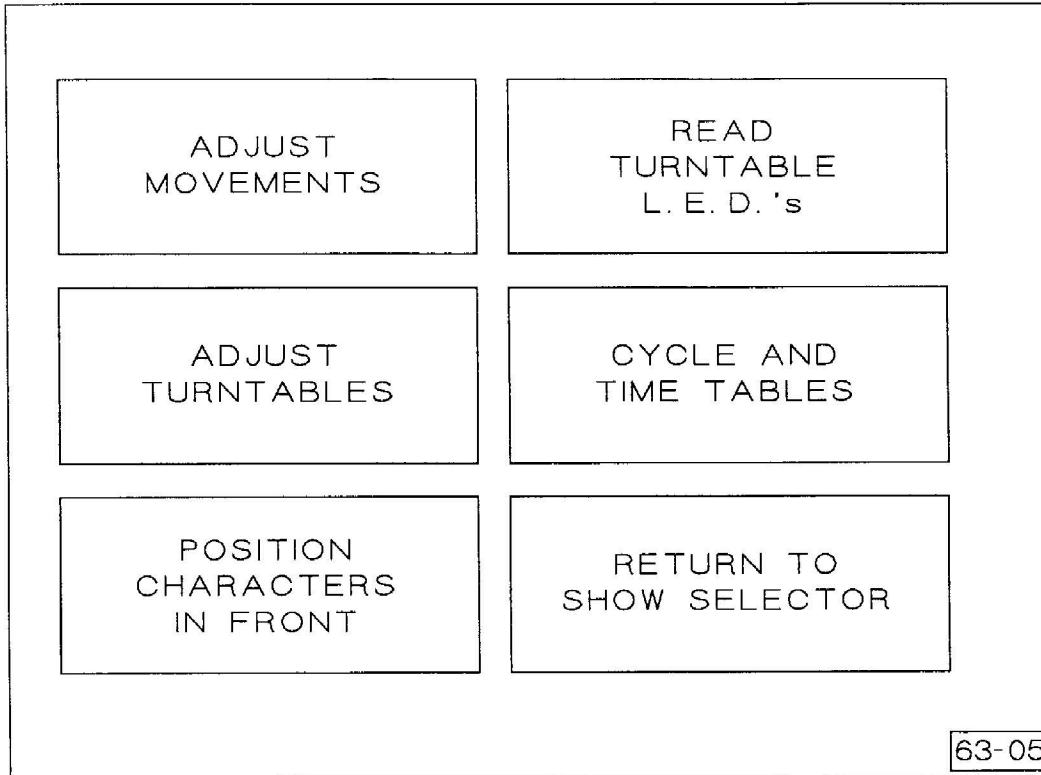

INFO: This is the main menu of the Show Adjustment Utilities.

ACTIVE BUTTONS: 6

ADJUST MOVEMENTS: Allows you to cycle or lock-on any pneumatic character movement(s), character servo(s), prop(s), or light(s). See page xx.

ADJUST TURNTABLES: Cycles any motor-driven turntable on the center stage, and indicates its speed, measured in the number of seconds it takes to travel from fully CW to fully CCW, and from fully CCW to fully CW. Also allows you to send each table to its "center" position. See page xx.

POSITION CHARACTERS IN FRONT: Automatically positions the large turntable to have any one or two center stage characters front-and-center, and have all three center stage characters facing forward at the same time. See page xx.

READ TURNTABLE L.E.D.'S: Displays the position of the large turntable and the three center stage character turntables. (The turntables' infrared positioning circuitry is described in both the CHARACTER TURNTABLES and LARGE TURNTABLE sections of the manual. The position numbers are explained at the end of this section in Turntable Positioning Exercise.) See page xx.

CYCLE AND TIME TABLES: Will automatically cycle any of the three center stage character turntables or the large turntable (one table at a time) ten times in each direction, and then display the average times of the CW and CCW rotations of the table. See page xx.

RETURN TO SHOW SELECTOR: Exits Show Adjustment Utilities altogether, and takes you back to the Startup panel of the Operating System.

Adjust Movements

This utility function is menu driven, but operates on keyboard input only, i.e., the lightpen is not used to make selections. There will be a highlight bar on each menu screen. You must use the arrow keys to move the bar up and down to highlight your choice, then press the Return key to make the selection.

In this utility, there are eight switches that start out unassigned. You can assign any one movement or any one light to any switch, and any combination of assigned or unassigned switches is acceptable. You can then command the system to cycle the switches on and off automatically, or simply turn the switches on and leave them on (until you turn them off).

Another option is to have the system AUTO ASSIGN switches for you. In this case, you choose a movement on Mitzi to assign to the first switch, and the system automatically assigns the same movement on the other characters (that have that movement) to successive switches. This is very useful in synchronizing character movements. (The reason Mitzi is the default character in AUTO ASSIGN is because while some characters may have less movements than Mitzi, no other character has a movement that Mitzi does not have.)

IMPORTANT: Since there are an infinite number of arrangements of characters, props, and lights that can be designed into a show, the menus in this subsection have been taken from a system that operates a full, three-stage show with every possible prop and light. Therefore, your actual menus may have less listings or options than the examples on the pages herein. Characters, props, and other controls that do not apply to your show's configuration will not be on your menus.

The first menu of Show Adjustment Utilities is shown on the next page.

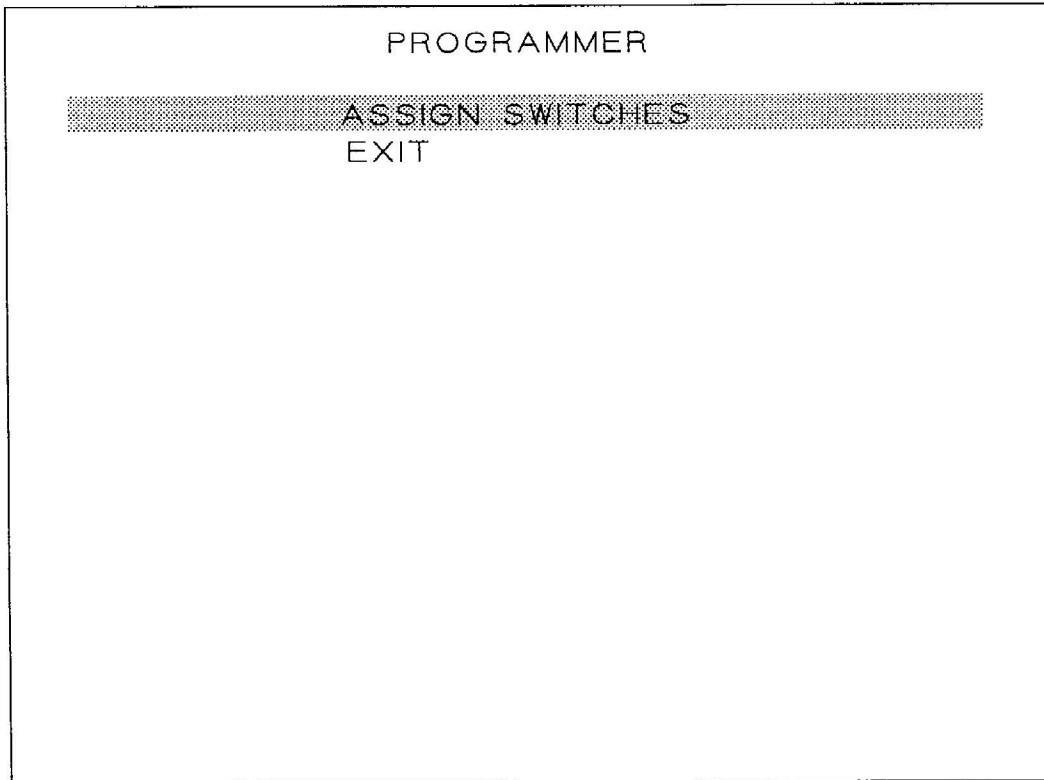

CHOICES: 2

ASSIGN SWITCHES: Goes to the main Switch Assignment screen shown on the next page.

EXIT: Returns to the main menu panel of the Show Adjustment Utilities.

SWITCH ASSIGNMENT

```
-----  
SW01 NOT ASSIGNED  
SW02 NOT ASSIGNED  
SW03 NOT ASSIGNED  
SW04 NOT ASSIGNED  
SW05 NOT ASSIGNED  
SW06 NOT ASSIGNED  
SW07 NOT ASSIGNED  
SW08 NOT ASSIGNED
```

```
CLEAR ALL SWITCHES  
MOVEMENTS ON  
1.0 SECOND TIMER  
AUTO ASSIGN FOR ADJUST  
EXIT
```

This is the main Switch Assignment screen. Here, you can pick a switch(s) to assign, clear all switches of any assignments, or activate switches that have already been assigned. Use the arrow keys to move the bar, and press Return to make the selection. Below are brief descriptions of the functions available on this screen. Following this page, and through the rest of this subsection, are four examples where you will be stepped through actual assignments to help familiarize you with assignment methods.

CHOICES: 13

SW01 through *SW08*: To assign one movement or light at a time, place the bar over the first available (not assigned) switch number, and press Return to see a list of things that can be assigned. See examples #1 and #2. Example #1 begins on page 5.

CLEAR ALL SWITCHES: Place the bar here and press Return to clear all previously assigned switches. The switches will then all say "not assigned."

MOVEMENTS ON: If you put the bar here and press Return, the system turns on all assigned movements (or lights) on the list, and leaves them on. Press the spacebar (or any other key) on the keyboard to turn them back off. See example #4 that begins on page 24.

1.0 SECOND TIMER: Put the bar here and press Return, and the system will automatically switch the assigned movements (or lights) on and off, repeatedly, using a predefined internal timer. Press the spacebar (or any other key) on the keyboard to stop the timer. NOTE: The timer is not actually one second in each direction (on or off). It's actually somewhere in between one and two seconds for most shows. The term "1.0 second timer" is merely a long-used name associated with this function. See examples #1 and #2. Example #1 begins on page 5.

AUTO ASSIGN FOR ADJUST: Place the bar here and press Return, and you will be shown a list of all possible Mitzi pneumatic movements that can be assigned to switch #1. The system will then automatically assign successive switches to that same movement in all other characters that have it. See example #3 that begins on page 21.

EXIT: Returns to the first menu shown back on page 2.

The first example begins on the next page.

SWITCH ASSIGNMENT

SW01	NOT ASSIGNED
SW02	NOT ASSIGNED
SW03	NOT ASSIGNED
SW04	NOT ASSIGNED
SW05	NOT ASSIGNED
SW06	NOT ASSIGNED
SW07	NOT ASSIGNED
SW08	NOT ASSIGNED

CLEAR ALL SWITCHES
MOVEMENTS ON
1.0 SECOND TIMER
AUTO ASSIGN FOR ADJUST
EXIT

EXAMPLE #1:

Let's suppose you want to cycle Mitzi's right elbow to adjust its movement speed. First, look at the switch list to ensure that all switches say NOT ASSIGNED. If any are assigned, then use the arrow keys to move the highlight bar down to CLEAR ALL SWITCHES, and press the Return key. Now all switches are cleared and should say NOT ASSIGNED. Next, you will want to assign Mitzi's right elbow to switch #1, so position the bar on SW01, and press Return. This will take you to the menu on the next page.

(go to the next page)

```
-----
                SWITCH ASSIGNMENT
-----
SWITCH = 01
MITZI PNEUMATICS
MITZI SERVOS
BILLYBOB PNEUMATICS
BILLYBOB SERVOS
FATZ PNEUMATICS
FATZ SERVOS
DOOK PNEUMATICS
DOOK SERVOS
BEACH BEAR PNEUMATICS
BEACH BEAR SERVOS
LOONEY BIRD-LAB PNEUMATICS
LOONEY BIRD-LAB SERVOS
LOONEY BIRD-WIN PNEUMATICS
LOONEY BIRD-WIN SERVOS
PROPS
CONTROLS
STAGE LIGHTS
COLOR AND STROBE LIGHTS
CLEAR THIS SWITCH
ASSIGN BIT NUMBER
EXIT
```

(example #1 cont.)

This list breaks up all of the movements and lights in to groups that make it easier to isolate the one you're after. Notice that the switch number that is ready to be assigned is displayed near the top-left of the screen - switch #1. Mitzi's right elbow is a pneumatic movement, so place the bar over MITZI PNEUMATICS, and press Return. This will take you to the menu on the next page.

NOTE: There is a complete list of movements and lights in each group on page 29.

(go to the next page)

```

-----
                SWITCH ASSIGNMENT
-----
SWITCH = 01                                MITZI
      MOUTH
      LIP
      HEAD TURN
      HEAD DOWN
      HEAD TILT RIGHT
      HEAD TILT LEFT
      BODY TURN RIGHT
      BODY TILT RIGHT
      BODY TILT LEFT
      KNEE BEND
      WRIST RIGHT
      WRIST LEFT
      ELBOW RIGHT
      ELBOW LEFT
      ARM TWIST RIGHT
      ARM TWIST LEFT
      ARM RAISE RIGHT
      ARM RAISE LEFT
      SHOULDER RIGHT
      SHOULDER LEFT
      EXIT

```

(example #1 cont.)

You are now presented a list of all pneumatic movements on Mitzi (except the ears). Since this is a list of individual movements (not groups), making a selection on this screen will actually assign the switch number displayed near the top-left of the screen - switch #1. Move the bar down to ELBOW RIGHT, and press Return. The moment you press Return, switch #1 is assigned Mitzi's right elbow, the bar moves down one row, and the indicator near the top-left of the screen changes to SWITCH = 02, indicating the system is now ready to assign a movement to switch #2, if you choose. This is shown on the next page.

(go to the next page)

```

                                SWITCH ASSIGNMENT
-----
SWITCH = 02                                MITZI
      MOUTH
      LIP
      HEAD TURN
      HEAD DOWN
      HEAD TILT RIGHT
      HEAD TILT LEFT
      BODY TURN RIGHT
      BODY TILT RIGHT
      BODY TILT LEFT
      KNEE BEND
      WRIST RIGHT
      WRIST LEFT
      ELBOW RIGHT
      ELBOW LEFT
      ARM TWIST RIGHT
      ARM TWIST LEFT
      ARM RAISE RIGHT
      ARM RAISE LEFT
      SHOULDER RIGHT
      SHOULDER LEFT
      EXIT

```

(example #1 cont.)

Your screen should now look similar to this. The system is ready to assign switch #2, but we're only interested in the one movement that has already been assigned. Move the bar down to EXIT as shown above, and press Return. This will take you back to the main Switch Assignment screen, as shown on the next page.

(go to the next page)

SWITCH ASSIGNMENT	
=====	
SW01	MITZI ELBOW RIGHT
SW02	NOT ASSIGNED
SW03	NOT ASSIGNED
SW04	NOT ASSIGNED
SW05	NOT ASSIGNED
SW06	NOT ASSIGNED
SW07	NOT ASSIGNED
SW08	NOT ASSIGNED
CLEAR ALL SWITCHES	
MOVEMENTS ON	
1.0 SECOND TIMER	
AUTO ASSIGN FOR ADJUST	
EXIT	

(example #1 cont.)

Back at the main screen, the switch assignment you just made is now on the list. Since the idea is to steadily cycle Mitzi's right elbow, move the bar down to 1.0 SECOND TIMER, and press Return. The screen does not change in appearance, but Mitzi's elbow movement begins - on, off, on, off, etc. When you want the movement to stop, press the spacebar (or any other key).

END OF EXAMPLE #1.

```

                                SWITCH ASSIGNMENT
=====
SW01                            NOT ASSIGNED
SW02                            NOT ASSIGNED
SW03                            NOT ASSIGNED
SW04                            NOT ASSIGNED
SW05                            NOT ASSIGNED
SW06                            NOT ASSIGNED
SW07                            NOT ASSIGNED
SW08                            NOT ASSIGNED

                                CLEAR ALL SWITCHES
                                MOVEMENTS ON
                                1.0 SECOND TIMER
                                AUTO ASSIGN FOR ADJUST
                                EXIT

```

EXAMPLE #2:

Let's suppose you want both Bill Bob and Fatz to raise both arms up and down using the timer. First, look at the switch list to ensure that all switches say NOT ASSIGNED. If any are assigned, then use the arrow keys to move the highlight bar down to CLEAR ALL SWITCHES, and press the Return key. Now all switches are cleared and should say NOT ASSIGNED. Next, you will want to assign the first of the four switches necessary to cycle four different movements at one time, so position the bar on SW01, and press Return. This will take you to the menu on the next page.

(go to the next page)

```

                                SWITCH ASSIGNMENT
-----
SWITCH = 01
    MITZI PNEUMATICS
    MITZI SERVOS
    BILLYBOB PNEUMATICS
    BILLYBOB SERVOS
    FATZ PNEUMATICS
    FATZ SERVOS
    DOOK PNEUMATICS
    DOOK SERVOS
    BEACH BEAR PNEUMATICS
    BEACH BEAR SERVOS
    LOONEY BIRD-LAB PNEUMATICS
    LOONEY BIRD-LAB SERVOS
    LOONEY BIRD-WIN PNEUMATICS
    LOONEY BIRD-WIN SERVOS
    PROPS
    CONTROLS
    STAGE LIGHTS
    COLOR AND STROBE LIGHTS
    CLEAR THIS SWITCH
    ASSIGN BIT NUMBER
    EXIT

```

(example #2 cont.)

This list breaks up all of the movements and lights in to groups that make it easier to isolate the one you're after. Notice that the switch number that is ready to be assigned is displayed near the top-left of the screen - switch #1. The four switches you need to assign can be assigned in any order, but let's start with Billy Bob's arms. Place the bar over BILLYBOB PNEUMATICS, and press Return. This will take you to the menu on the next page.

NOTE: There is a complete list of movements and lights in each group on page 29.

(go to the next page)

```

                                SWITCH ASSIGNMENT
=====
SWITCH = 01                                BILLYBOB
      MOUTH
      LIP
      HEAD TURN
      HEAD DOWN
      HEAD TILT RIGHT
      HEAD TILT LEFT
      BODY TURN RIGHT
      BODY TILT RIGHT
      BODY TILT LEFT
      KNEE BEND
      WRIST RIGHT
      WRIST LEFT
      ELBOW RIGHT
      ELBOW LEFT
      ARM TWIST RIGHT
      ARM TWIST LEFT
      ARM RAISE RIGHT
      ARM RAISE LEFT
      SHOULDER RIGHT
      SHOULDER LEFT
      EXIT

```

(example #2 cont.)

You are now presented a list of all pneumatic movements on Billy Bob. Move the bar down to ARM RAISE RIGHT, and press Return. The moment you press Return, switch #1 is assigned Billy Bob's right arm raise movement, the bar moves down one row, and the indicator near the top-left of the screen changes to SWITCH = 02, indicating the system is now ready to assign a movement to switch #2, if you choose. This is shown on the next page.

(go to the next page)

```

-----
                SWITCH ASSIGNMENT
-----
SWITCH = 02                                BILLYBOB
      MOUTH
      LIP
      HEAD TURN
      HEAD DOWN
      HEAD TILT RIGHT
      HEAD TILT LEFT
      BODY TURN RIGHT
      BODY TILT RIGHT
      BODY TILT LEFT
      KNEE BEND
      WRIST RIGHT
      WRIST LEFT
      ELBOW RIGHT
      ELBOW LEFT
      ARM TWIST RIGHT
      ARM TWIST LEFT
      ARM RAISE RIGHT
      ARM RAISE LEFT
      SHOULDER RIGHT
      SHOULDER LEFT
      EXIT

```

(example #2 cont.)

Your screen should now look similar to this. The system is ready to assign switch #2. The next movement we want to assign (to switch #2) is on this same list, so move the bar down to ARM RAISE LEFT, and press Return. The moment you press Return, switch #2 is assigned Billy Bob's left arm raise movement, the bar moves down one row, and the indicator near the top-left of the screen changes to SWITCH = 03, indicating the system is now ready to assign a movement to switch #3, if you choose. This is shown on the next page.

(go to the next page)

```

                                SWITCH ASSIGNMENT
-----
SWITCH = 03                                BILLYBOB
      MOUTH
      LIP
      HEAD TURN
      HEAD DOWN
      HEAD TILT RIGHT
      HEAD TILT LEFT
      BODY TURN RIGHT
      BODY TILT RIGHT
      BODY TILT LEFT
      KNEE BEND
      WRIST RIGHT
      WRIST LEFT
      ELBOW RIGHT
      ELBOW LEFT
      ARM TWIST RIGHT
      ARM TWIST LEFT
      ARM RAISE RIGHT
      ARM RAISE LEFT
      SHOULDER RIGHT
      SHOULDER LEFT
      EXIT

```

(example #2 cont.)

Your screen should now look similar to this. The system is ready to assign switch #3, but the next two movements we want to assign do not belong to Billy Bob. Move the bar down to EXIT as shown above, and press Return. This will take you back to the main Switch Assignment screen, as shown on the next page.

(go to the next page)

SWITCH ASSIGNMENT	

SW01	BILLYBOB ARM RAISE RIGHT
SW02	BILLYBOB ARM RAISE LEFT
SW03	NOT ASSIGNED
SW04	NOT ASSIGNED
SW05	NOT ASSIGNED
SW06	NOT ASSIGNED
SW07	NOT ASSIGNED
SW08	NOT ASSIGNED

CLEAR ALL SWITCHES
MOVEMENTS ON
1.0 SECOND TIMER
AUTO ASSIGN FOR ADJUST
EXIT

(example #2 cont.)

Back at the main screen, your screen should look similar to this. The first two switch assignments you just made are now on the list. Now we're ready to assign Fatz's arm raises to switches #3 and #4. Make sure the bar is on SW03, and press Return. This will take you to the menu on the next page.

(go to the next page)

```
                SWITCH ASSIGNMENT
-----
SWITCH = 03
    MITZI PNEUMATICS
    MITZI SERVOS
    BILLYBOB PNEUMATICS
    BILLYBOB SERVOS
    FATZ PNEUMATICS
    FATZ SERVOS
    DOOK PNEUMATICS
    DOOK SERVOS
    BEACH BEAR PNEUMATICS
    BEACH BEAR SERVOS
    LOONEY BIRD-LAB PNEUMATICS
    LOONEY BIRD-LAB SERVOS
    LOONEY BIRD-WIN PNEUMATICS
    LOONEY BIRD-WIN SERVOS
    PROPS
    CONTROLS
    STAGE LIGHTS
    COLOR AND STROBE LIGHTS
    CLEAR THIS SWITCH
    ASSIGN BIT NUMBER
    EXIT
```

(example #2 cont.)

The switch number that is ready to be assigned is displayed near the top-left of the screen - switch #3. Place the bar over FATZ PNEUMATICS, and press Return. This will take you to the menu on the next page.

NOTE: There is a complete list of movements and lights in each group on page 29.

(go to the next page)

```

                                SWITCH ASSIGNMENT
=====
SWITCH = 03                                FATZ
      MOUTH
      LIP
      HEAD TURN
      HEAD DOWN
      HEAD TILT RIGHT
      HEAD TILT LEFT
      BODY TURN RIGHT
      BODY TILT RIGHT
      BODY TILT LEFT
      KNEE BEND
      WRIST RIGHT
      WRIST LEFT
      ELBOW RIGHT
      ELBOW LEFT
      ARM TWIST RIGHT
      ARM TWIST LEFT
      ARM RAISE RIGHT
      ARM RAISE LEFT
      SHOULDER RIGHT
      SHOULDER LEFT
      EXIT

```

(example #2 cont.)

You are now presented a list of all pneumatic movements on Fatz. Move the bar down to ARM RAISE RIGHT, and press Return. The moment you press Return, switch #3 is assigned Fatz's right arm raise movement, the bar moves down one row, and the indicator near the top-left of the screen changes to SWITCH = 04, indicating the system is now ready to assign a movement to switch #4, if you choose. This is shown on the next page.

(go to the next page)

```

                                SWITCH ASSIGNMENT
=====
SWITCH = 04                                FATZ
      MOUTH
      LIP
      HEAD TURN
      HEAD DOWN
      HEAD TILT RIGHT
      HEAD TILT LEFT
      BODY TURN RIGHT
      BODY TILT RIGHT
      BODY TILT LEFT
      KNEE BEND
      WRIST RIGHT
      WRIST LEFT
      ELBOW RIGHT
      ELBOW LEFT
      ARM TWIST RIGHT
      ARM TWIST LEFT
      ARM RAISE RIGHT
      ARM RAISE LEFT
      SHOULDER RIGHT
      SHOULDER LEFT
      EXIT

```

(example #2 cont.)

Your screen should now look similar to this. The system is ready to assign switch #4. The next movement we want to assign (to switch #4) is on this same list, so move the bar down to ARM RAISE LEFT, and press Return. The moment you press Return, switch #4 is assigned Fatz's left arm raise movement, the bar moves down one row, and the indicator near the top-left of the screen changes to SWITCH = 05, indicating the system is now ready to assign a movement to switch #5, if you choose. This is shown on the next page.

(go to the next page)

```

                                SWITCH ASSIGNMENT
-----
SWITCH = 05                                FATZ
      MOUTH
      LIP
      HEAD TURN
      HEAD DOWN
      HEAD TILT RIGHT
      HEAD TILT LEFT
      BODY TURN RIGHT
      BODY TILT RIGHT
      BODY TILT LEFT
      KNEE BEND
      WRIST RIGHT
      WRIST LEFT
      ELBOW RIGHT
      ELBOW LEFT
      ARM TWIST RIGHT
      ARM TWIST LEFT
      ARM RAISE RIGHT
      ARM RAISE LEFT
      SHOULDER RIGHT
      SHOULDER LEFT
      EXIT

```

(example #2 cont.)

Your screen should now look similar to this. The system is ready to assign switch #5, but we don't want to assign any more movements. Move the bar down to EXIT as shown above, and press Return. This will take you back to the main Switch Assignment screen, as shown on the next page.

(go to the next page)

```

                                SWITCH ASSIGNMENT
-----
SW01      BILLYBOB ARM RAISE RIGHT
SW02      BILLYBOB ARM RAISE LEFT
SW03      FATZ ARM RAISE RIGHT
SW04      FATZ ARM RAISE LEFT
SW05      NOT ASSIGNED
SW06      NOT ASSIGNED
SW07      NOT ASSIGNED
SW08      NOT ASSIGNED

                                CLEAR ALL SWITCHES
                                MOVEMENTS ON
                                1.0 SECOND TIMER
                                AUTO ASSIGN FOR ADJUST
                                EXIT

```

(example #2 cont.)

Back at the main screen, your screen should look similar to this. The four switch assignments you made are now on the list. Since the idea is to steadily cycle all four arm-raises, move the bar down to 1.0 SECOND TIMER, and press Return. The screen does not change in appearance, but Billy Bob's and Fatz's arm-raise movements begin - on, off, on, off, etc. When you want the movements to stop, press the spacebar (or any other key).

END OF EXAMPLE #2.

```

                                SWITCH ASSIGNMENT
=====
SW01                          NOT ASSIGNED
SW02                          NOT ASSIGNED
SW03                          NOT ASSIGNED
SW04                          NOT ASSIGNED
SW05                          NOT ASSIGNED
SW06                          NOT ASSIGNED
SW07                          NOT ASSIGNED
SW08                          NOT ASSIGNED

                                CLEAR ALL SWITCHES
                                MOVEMENTS ON
                                1.0 SECOND TIMER
                                AUTO ASSIGN FOR ADJUST
                                EXIT

```

EXAMPLE #3:

Let's suppose you want to cycle the body turn movements of all the characters, simultaneously, to make sure they are all set at the proper speed, and synchronized to each other. First, look at the switch list to ensure that all switches say NOT ASSIGNED. If any are assigned, then use the arrow keys to move the highlight bar down to CLEAR ALL SWITCHES, and press the Return key. Now all switches are cleared and should say NOT ASSIGNED. Next, you will want to see a list of character movements that can be automatically assigned, so position the bar on AUTO ASSIGN FOR ADJUST, and press Return. This will take you to the menu on the next page.

(go to the next page)

```
-----
                SWITCH ASSIGNMENT
-----
SWITCH = 01                                MITZI
      MOUTH
      LIP
      HEAD TURN
      HEAD DOWN
      HEAD TILT RIGHT
      HEAD TILT LEFT
      BODY TURN RIGHT
      BODY TILT RIGHT
      BODY TILT LEFT
      KNEE BEND
      WRIST RIGHT
      WRIST LEFT
      ELBOW RIGHT
      ELBOW LEFT
      ARM TWIST RIGHT
      ARM TWIST LEFT
      ARM RAISE RIGHT
      ARM RAISE LEFT
      SHOULDER RIGHT
      SHOULDER LEFT
      EXIT
```

(example #3 cont.)

You are now presented a list of all pneumatic movements on Mitzi (except the ears). Remember, Mitzi is the default character used to pick auto-assign movements. Move the bar down to BODY TURN RIGHT, and press Return. The moment you press Return, the switches (however many are needed) are automatically assigned to the body turn-right movements of all characters that have that particular movement. The system then automatically returns to the main screen as shown on the next page.

(go to the next page)

```

                                SWITCH ASSIGNMENT
=====
SW01          MITZI BODY TURN RIGHT
SW02          BILLYBOB BODY TURN RIGHT
SW03          FATZ BODY TURN RIGHT
SW04          DOOK BODY TURN RIGHT
SW05          BEACH BEAR BODY TURN RIGHT
SW06 LOONEY BIRD-LAB BODY TURN RIGHT
SW07          NOT ASSIGNED
SW08          NOT ASSIGNED

                                CLEAR ALL SWITCHES
                                MOVEMENTS ON
                                1.0 SECOND TIMER
                                AUTO ASSIGN FOR ADJUST
                                EXIT

```

(example #3 cont.)

Back at the main screen, your screen should look similar to this. The switch assignments that the system made for you are now on the list. Since the idea is to steadily cycle all body turn movements simultaneously, move the bar down to 1.0 SECOND TIMER, and press Return. The screen does not change in appearance, but all characters with body turn-right movements begin to move - on, off, on, off, etc. When you want the movements to stop, press the spacebar (or any other key).

END OF EXAMPLE #3.

SWITCH ASSIGNMENT

```
-----  
SW01 NOT ASSIGNED  
SW02 NOT ASSIGNED  
SW03 NOT ASSIGNED  
SW04 NOT ASSIGNED  
SW05 NOT ASSIGNED  
SW06 NOT ASSIGNED  
SW07 NOT ASSIGNED  
SW08 NOT ASSIGNED
```

```
      CLEAR ALL SWITCHES  
      MOVEMENTS ON  
      1.0 SECOND TIMER  
      AUTO ASSIGN FOR ADJUST  
      EXIT
```

EXAMPLE #4:

Let's suppose you want to turn on the blue neon note and have it stay on to check its operation. According to the PROPS / LIGHTS section of the manual, the blue neon light is Note #2. First, look at the switch list to ensure that all switches say NOT ASSIGNED. If any are assigned, then use the arrow keys to move the highlight bar down to CLEAR ALL SWITCHES, and press the Return key. Now all switches are cleared and should say NOT ASSIGNED. Next, you will want to assign Note #2 to switch #1, so position the bar on SW01, and press Return. This will take you to the menu on the next page.

(go to the next page)

```
-----
                SWITCH ASSIGNMENT
=====
SWITCH = 01
    MITZI PNEUMATICS
    MITZI SERVOS
    BILLYBOB PNEUMATICS
    BILLYBOB SERVOS
    FATZ PNEUMATICS
    FATZ SERVOS
    DOOK PNEUMATICS
    DOOK SERVOS
    BEACH BEAR PNEUMATICS
    BEACH BEAR SERVOS
    LOONEY BIRD-LAB PNEUMATICS
    LOONEY BIRD-LAB SERVOS
    LOONEY BIRD-WIN PNEUMATICS
    LOONEY BIRD-WIN SERVOS
    PROPS
    CONTROLS
    STAGE LIGHTS
    COLOR AND STROBE LIGHTS
    CLEAR THIS SWITCH
    ASSIGN BIT NUMBER
    EXIT
```

(example #4 cont.)

This list breaks up all of the movements and lights in to groups that make it easier to isolate the one you're after. Notice that the switch number that is ready to be assigned is displayed near the top-left of the screen - switch #1. Note #2 is in the STAGE LIGHTS group, so place the bar over STAGE LIGHTS, and press Return. This will take you to the menu on the next page.

NOTE: There is a complete list of movements and lights in each group on page 29.

(go to the next page)

```

                                SWITCH ASSIGNMENT
=====
SWITCH = 01                      STAGE LIGHTS
    STAGE RIGHT SPOT
    CNTR STAGE RIGHT
    CNTR STAGE CNTR
    CNTR STAGE LEFT
    STAGE LEFT SPOT
    ROCKAFIRE NEON
    EXPLOSION NEON
    RIGHT FLOOR SPOT
    LEFT FLOOR SPOT
    NOTE #1
    NOTE #2
    NOTE #3
    NOTE #4
    EXIT

```

(example #4 cont.)

You are now presented a list of all lights in the STAGE LIGHTS group. Since this is a list of individual lights (not groups), making a selection on this screen will actually assign the switch number displayed near the top-left of the screen - switch #1. Move the bar down to NOTE #2, and press Return. The moment you press Return, switch #1 is assigned neon Note #2, the bar moves down one row, and the indicator near the top-left of the screen changes to SWITCH = 02, indicating the system is now ready to assign a movement to switch #2, if you choose. This is shown on the next page.

(go to the next page)

```
                SWITCH ASSIGNMENT
-----
SWITCH = 02                STAGE LIGHTS
    STAGE RIGHT SPOT
    CNTR STAGE RIGHT
    CNTR STAGE CNTR
    CNTR STAGE LEFT
    STAGE LEFT SPOT
    ROCKAFIRE NEON
    EXPLOSION NEON
    RIGHT FLOOR SPOT
    LEFT FLOOR SPOT
    NOTE #1
    NOTE #2
    NOTE #3
    NOTE #4
    EXIT
```

(example #4 cont.)

Your screen should now look similar to this. The system is ready to assign switch #2, but, this time, we're only interested in the one light that has already been assigned. Move the bar down to EXIT as shown above, and press Return. This will take you back to the main Switch Assignment screen, as shown on the next page.

(go to the next page)

```

                                SWITCH ASSIGNMENT
=====
SW01          STAGE LIGHTS NOTE #2
SW02          NOT ASSIGNED
SW03          NOT ASSIGNED
SW04          NOT ASSIGNED
SW05          NOT ASSIGNED
SW06          NOT ASSIGNED
SW07          NOT ASSIGNED
SW08          NOT ASSIGNED

                                CLEAR ALL SWITCHES
                                MOVEMENTS ON
                                1.0 SECOND TIMER
                                AUTO ASSIGN FOR ADJUST
                                EXIT

```

(example #4 cont.)

Back at the main screen, the switch assignment you just made is now on the list. Since the idea this time is to turn the light on and have it stay on, move the bar down to MOVEMENTS ON, and press Return. The screen does not change in appearance, but the blue neon Note #2 is now on. When you want the light to turn back off, press the spacebar (or any other key).

END OF EXAMPLE #4.

ASSIGNMENT GROUPS

IMPORTANT: These are general lists to help you identify the types of movements or lights in each group. The lists on your system may differ from these examples and other shows' lists.

PNEUMATICS for MITZI, BILLY BOB, FATZ, DOOK, & BEACH BEAR

MOUTH (open)
LIP (down)
HEAD TURN (right)
HEAD DOWN
HEAD TILT RIGHT
HEAD TILT LEFT
BODY TURN RIGHT
BODY TILT RIGHT
BODY TILT LEFT
KNEE BEND
WRIST RIGHT
WRIST LEFT
ELBOW RIGHT
ELBOW LEFT
ARM TWIST RIGHT
ARM TWIST LEFT
ARM RAISE RIGHT
ARM RAISE LEFT
SHOULDER RIGHT (raise)
SHOULDER LEFT (raise)

PNEUMATICS for LOONEY BIRD - LAB

MOUTH (open)
LIP (down)
HEAD TURN (right)
HEAD DOWN
HEAD TILT RIGHT
HEAD TILT LEFT
WRIST RIGHT
WRIST LEFT
ELBOW RIGHT
ELBOW LEFT
ARM TWIST RIGHT
ARM TWIST LEFT
SHOULDER RIGHT (raise)
SHOULDER LEFT (raise)
BODY TURN (right)

PNEUMATICS for LOONEY BIRD - WINDOW

MOUTH (open)
LIP (down)
HEAD DOWN
HEAD TURN (right)

SERVOS for all characters

EYES RIGHT
EYES LEFT
EYES DOWN
EYES UP
LIDS CLOSE
LIDS OPEN
EARS (for Mitzi and Dook only)

PROPS

COMPUTER SWIVEL (turn Looney's monitor)
BBEAR WINDOW (window that hides Looney's head)
COCONUT DROP (above Beach Bear's head)
SPEAKER LEFT (both left prop speakers)
SPEAKER RIGHT (both right prop speakers)
RABBIT EARS TOP LEFT (on big TV)
RABBIT EARS TOP RIGHT (on big TV)
RABBIT EARS BOTTOM LEFT (on big TV)
RABBIT EARS BOTTOM RIGHT (on big TV)
APPLAUSE SIGN (over Karaoke stage)
KARAOKE SPOT (aimed at singer)

CONTROLS

TURN STAGE RIGHT (Beach Bear / Looney Lab stage)
TURN STAGE LEFT (Dook / big TV stage)
STAGE RIGHT CURTAIN
STAGE LEFT CURTAIN
CENTER STAGE CURTAIN
BBOB BODY TURN RIGHT (Toy show only)
BBOB BODY TURN LEFT (Toy show only)

STAGE LIGHTS

STAGE RIGHT SPOT (character face spot)
CENTER STAGE RIGHT (character face spot)
CENTER STAGE CENTER (character face spot)
CENTER STAGE LEFT (character face spot)
STAGE LEFT SPOT (character face spot)
ROCKAFIRE NEON
EXPLOSION NEON
RIGHT FLOOR SPOT (overhead spot on stage-right)
LEFT FLOOR SPOT (overhead spot on stage-left)
NOTE #1 (yellow)
NOTE #2 (blue)
NOTE #3 (pink)
NOTE #4 (purple)

COLOR AND STROBE LIGHTS

COLOR LIGHT #1 (center stage effect)
COLOR LIGHT #2 (center stage effect)
COLOR LIGHT #3 (center stage effect)
COLOR LIGHT #4 (center stage effect)
COLOR LIGHT #5 (center stage effect)
COLOR LIGHT #6 (center stage effect)
COLOR LIGHT #7 (center stage effect)
COLOR LIGHT #8 (center stage effect)
COLOR LIGHT #9 (center stage effect)
STROBE (over center stage)
LOONEY SET LIGHT (window light)
DOOK WINDOW (light in house's window)

CLEAR THIS SWITCH

Clears any assignment for the switch indicated near the top-left of the screen. Clears only this switch and no others that may be assigned.

Adjust Turntables

This utility function is used for checking the speeds of the three character (small) turntables and the large turntable, all of which are driven by air motors. If you don't understand how these turntables operate, please read the CHARACTER TURNTABLES and LARGE TURNTABLE sections of the manual.

CW = Clockwise CCW = Counterclockwise

When you choose a button from the menu that sends a turntable to its fully CW or fully CCW position, the system counts the number of seconds the air motor is turning the table until the table reaches the point where the infrared readers shut off the motor. The reading will only be accurate if the table is turning from one extreme position to the other, i.e., not starting out somewhere in between its fully CW and fully CCW position. Please see the WEEKLY maintenance schedule in the MAINTENANCE section of the manual for ideal turntable speeds.

Keep in mind that the turntable mechanisms will initially rotate a bit slower than normal if they haven't been running in the past few minutes. When checking a turntable's times, always cycle the table from one extreme to the other (CW to CCW, CCW to CW, etc.) a couple times without paying attention to the readings. This will not only loosen up the mechanism, it will also insure that the table will be traveling from one extreme position to the other when you begin noting the readings.

Also remember that when adjusting the speed of one direction, it will have a slight affect on the speed of the other direction. Always make sure you have two or three good readings in both directions before moving on.

For shows with Karaoke, this utility can be operated from the Karaoke menu as well as at the computer.

The main panel is shown on the next page.

63
03

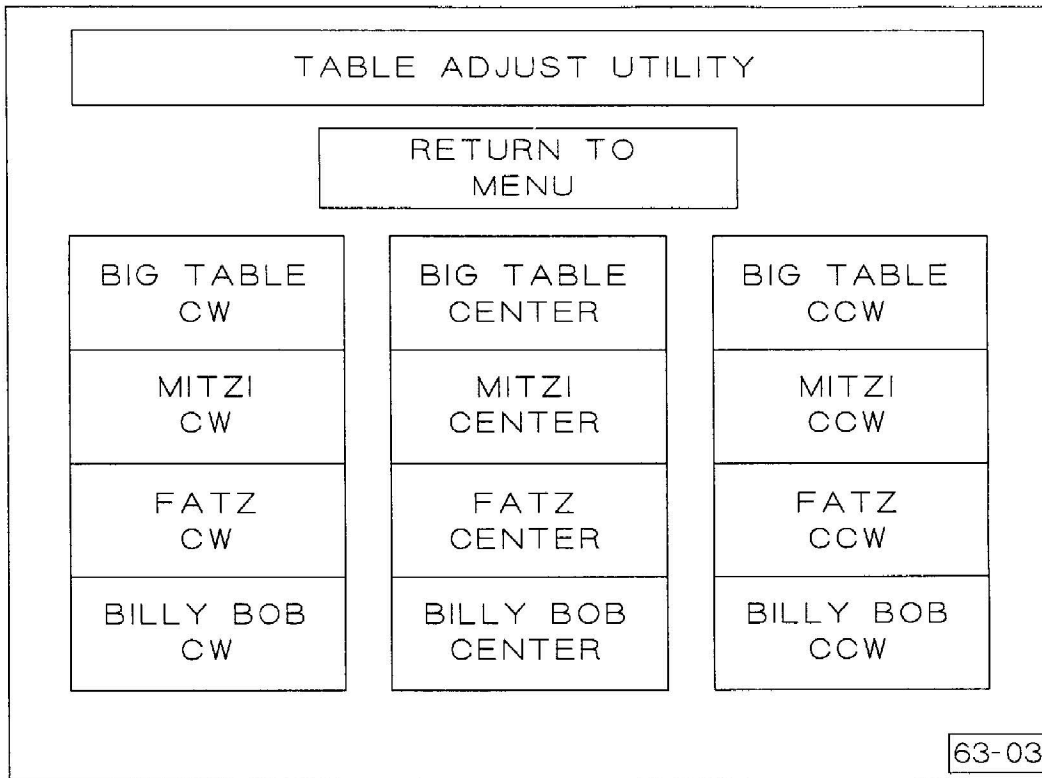

INFO: From this main panel, you can instruct any of the four turntables to go to its fully CW, fully CCW, or CENTER position.

ACTIVE BUTTONS: 13

Choosing any *CW* or *CCW* button will start the table turning and show you the timer screen shown on page 3.

Choosing any *CENTER* button will start the table turning and show you the screen shown on page 4.

RETURN TO MENU: Returns to the main menu panel of the Show Adjustment Utilities.

06.1

PRESS SPACEBAR OR CLICK PEN FOR MENU

When this screen first appears, the table will most likely still be rotating, and there will be no time reading displayed on the screen. After the table stops, the system will display the reading on the screen, rounded to the nearest tenth of a second. The timer for the character turntables has a maximum of 10 seconds, so if the table takes more than 10 seconds to get to get to where it's going (which is way too slow), the timer will stop at 10 seconds and display 10.0 on the screen. (The big table's timer has a maximum of 20 seconds.)

If the character turntable was already at the position you were attempting to send it to, the table won't move at all. In this case, the timer will run up to the 10 second maximum and stop, displaying the 10.0 on the screen. (The same is true of the big table, except the timer will run up to the 20 second maximum.)

After the timer reading appears, this screen will remain on the monitor until you press the spacebar (or the Karaoke push-button if your show is so equipped), which returns you to the main panel shown on page 2.

PRESS SPACEBAR OR CLICK PEN FOR MENU

NO TIME READINGS ON MOVES TO CENTER

When this screen first appears, the table will most likely still be rotating. As the screen indicates, there are NO time readings associated with tables being sent to their CENTER positions.

If the turntable was already at its CENTER position to start with, the table won't move at all.

After the table stops at its CENTER position, this screen will remain on the monitor until you press the spacebar (or the Karaoke push-button if your show is so equipped), which returns you to the main panel shown on page 2.

Position Characters In Front

This utility function is used for checking the positioning feature of the center stage turntables - the three character (small) turntables and the large turntable. If you don't understand how these turntables operate, please read the CHARACTER TURNTABLES and LARGE TURNTABLE sections of the manual.

CW = Clockwise CCW = Counterclockwise

By pressing a single key of the keyboard, you command the system to rotate the large turntable to position any one character or any two characters up front (toward the audience). When a single character is sent up front, the character should be front-and-center (or very close to it). When two characters are sent up front, the two characters should be an equal distance from the center line of the stage (or very close to it). In either case, regardless of where the large turntable stops, the system will have rotated the three individual characters turntables so that the characters themselves should be facing directly forward (or very close to it).

The phrase "or very close to it" is added because the system recognizes the fact that the turntables coast a bit after the air motor is shut off. Consequently, the system shuts off the air motor just before the table reaches the target position, and relies on the coasting to bring the table to its mark. Depending on the tightness of the table and the table's speed, the amount of coasting can vary slightly. However, under normal conditions, you can expect the table to stop within 5 degrees on either side of the target position.

NOTE: 5 degrees on a character turntable is roughly 1 inch along the circumference of the table. 5 degrees on the large turntable is roughly 5 inches along its circumference.

Should a table not stop within 5 degrees of the target position, then consider the following:

- 1) If the table is stopping a little bit short of the target area, check the table's speed by using ADJUST TURNTABLES.
- 2) Similarly, if the table is stopping a little beyond the target area, check the table's speed by using ADJUST TURNTABLES.
- 3) If the table(s) are stopping nowhere near the proper positions, the table(s) is most likely out of sync. In this case, following the instructions in the CHARACTER TURNTABLES or LARGE TURNTABLE section of the manual to check the sync of the table in question.

Keep in mind that the turntable mechanisms will initially rotate a bit slower than normal if they haven't been running in the past few minutes. To "loosen up" the tables, choose a few options at random from the menu screen (shown on the next page) to exercise the tables. Then choose the positions you are interested in checking.

The menu screen is shown on the next page.

ESCAPE TO EXIT PROGRAM

0. STOP TABLE
1. BBOB FRONT (CW)
2. BBOB & MITZI FRONT
3. MITZI FRONT
4. FATZ & MITZI FRONT
5. FATZ FRONT
6. BBOB & FATZ FRONT
7. BBOB FRONT (CCW)
8. BBOB BY TV (CCW)

SELECT OPTION

This screen uses keyboard input only (no lightpen). Simply press a number key from 0 to 8 to command the system to send the large turntable to the position indicated. When you are through, press the ESC key.

CHOICES: 10

0. STOP TABLE: Pressing the 0 key will instantly stop the large table wherever it is when you press 0.

1. BBOB FRONT (CW): Billy Bob has two front-and-center positions. This is the CW one, which, by the way, is the large turntable's fully clockwise position.

2. BBOB & MITZI FRONT: Billy Bob and Mitzi equal distances from the center line of the stage.

3. MITZI FRONT: Mitzi front-and-center.

4. FATZ & MITZI FRONT: Fatz and Mitzi equal distances from the center line of the stage.

5. FATZ FRONT: Fatz front-and-center.

6. BBOB & FATZ FRONT: Billy Bob and Fatz equal distances from the center line of the stage.

7. BBOB FRONT (CCW): This is Billy Bob's other front-and-center position. From this position, the large turntable is capable of rotating one full revolution clockwise to get to BBOB FRONT (CW), or rotating about 45 degrees counterclockwise to get to BBOB BY TV (CCW). This position, BBOB FRONT (CCW), is the standard starting position of the large table.

8. BBOB BY TV (CCW): This places the large turntable at its fully CCW position, which puts Billy Bob close to the large screen TV.

ESC: Returns to the main menu panel of the Show Adjustment Utilities.

Read Turntable L.E.D.'s

This is a simple utility that indicates the present position of the four center stage turntables - the three character (small) turntables and the large turntable. If you don't understand how these turntables operate, please read the CHARACTER TURNTABLES and LARGE TURNTABLE sections of the manual.

The system continues to monitor the position of all four tables and displays the positions on the screen. If you manually move any table, the position displayed on the screen will change.

To better understand the position numbers that this utility displays, please read Turntable Positioning Exercise in this section of the manual.

IMPORTANT: If you plan on manually (by hand) rotating tables to check the system's ability to read position numbers, always remember the CAUTION's detailed in the CHARACTER TURNTABLES and LARGE TURNTABLE sections of the manual:

- 1) Turning a character table too far in either direction can damage the "stop" mechanism.
- 2) Turning the large table to far in either direction can trigger the limit switch.

The screen for this utility is shown on the next page.

CENTER TABLE	01
MITZI TABLE	07
BILLY BOB TABLE	07
FATZ TABLE	07

PRESS ANY KEY TO RETURN TO MENU

This screen shows the current location of the four center stage, motor-driven turntables. The character turntable positions are numbered 0 through 14, with the number 15 reserved to indicate that the table is in between readable positions. Similarly, the large (center) table positions are numbered 0 through 30, with the number 31 reserved to indicate that the table is in between readable positions. All turntable position numbers increase when the table is rotating CW, and decrease when the table is turning CCW.

Pressing any key of the keyboard will return to the main menu panel of the Show Adjustment Utilities.

TECHNICAL NOTE: When Billy Bob is at his CCW front-and-center position, the large table is at or near its number 1 position. A little farther CCW is the number 0 position. However, the fully CCW position of the large table (where Billy Bob is over by the TV) is about 30 degrees farther CCW than the number 0 position. Though there are no readable position numbers in this area (number 31 is displayed), the system is capable of sending the large table to its fully CCW position by rotating the large table CCW for "X" number of seconds after passing the 0 position.

Cycle And Time Tables

This utility function is used to thoroughly cycle and check the speeds of the three character (small) turntables and the large turntable, all of which are driven by air motors. Unlike the Adjust Turntables utility where you command the table to rotate one direction at a time, this utility simulates the conditions of actually running a show, while averaging the amount of time it takes for the table to travel from one extreme position (CW or CCW) to the other. If you don't understand how these turntables operate, please read the CHARACTER TURNTABLES and LARGE TURNTABLE sections of the manual.

CW = Clockwise CCW = Counterclockwise

When you choose a button from the menu, the system will automatically cycle the table you've chosen 10 times. Rotating fully to one extreme position (CW or CCW), then back to the other extreme constitutes one time. After the system finishes cycling the table, it reports the average time for each direction.

The system recognizes the fact that the turntable mechanisms will initially rotate a bit slower than normal if they haven't been running in the past few minutes. The system also knows that the table will probably start out somewhere in between the two extremes on the first cycle. Therefore, for both reasons, when calculating the average times for a table, the system "throws out" the first couple readings for each direction.

If either of the turntable's average times is unacceptable, use the Adjust Turntables utility to rotate the table one direction at a time while making adjustments.

The main panel is shown on the next page.

63
04

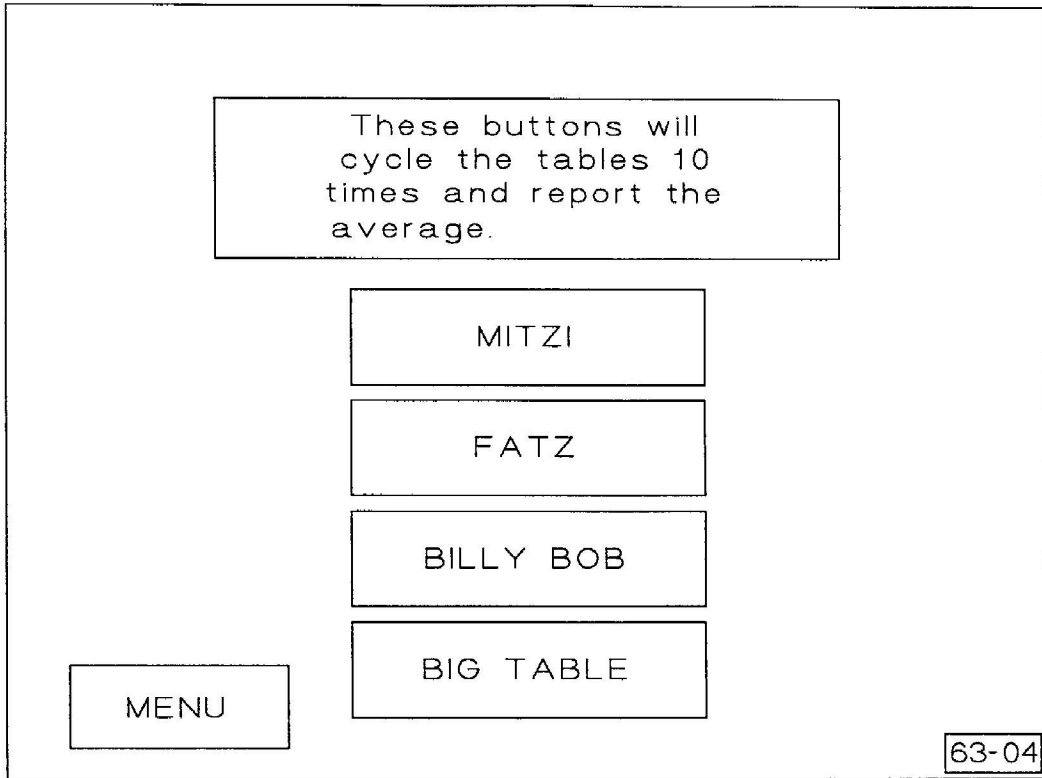

INFO: From this main panel, you can command the system to cycle any of the four turntables of the center stage. Pressing any button (except *MENU*) will take you to the screen shown on the next page.

ACTIVE BUTTONS: 5

MITZI: Begins cycling the Mitzi turntable and shows you the timer screen shown on the next page.

FATZ: Begins cycling the Fatz turntable and shows you the timer screen shown on the next page.

BILLY BOB: Begins cycling the Billy Bob turntable and shows you the timer screen shown on the next page.

BIG TABLE: Begins cycling the large turntable and shows you the timer screen shown on the next page.

MENU: Returns to the main menu panel of the Show Adjustment Utilities.

CW	06.0
CCW	06.1

When this screen first appears, the table will begin rotating, and there will only be a zero time reading on the screen. Each time the table briefly stops at the end of each direction's rotation, the system will flash that particular reading on the screen, rounded to the nearest tenth of a second (in case you want to stand there and watch the readings). After the system has finished cycling the table 10 times, it will display the average times for each direction on the screen as shown in the example above.

After the timer readings appear, this screen will remain on the monitor until you press the spacebar, which returns you to the main panel shown on page 2.

Turntable Positioning Exercise

BACKGROUND: For each character table, there are 15 readable positions, numbered 0-14, with number 15 reserved to indicate "in between." The center position is 7. Turning the table counterclockwise, the position numbers decrease to 0; turning the table clockwise, the numbers increase to 14. There will usually be "garbage" numbers just before and just after the true position number - this is completely normal. For example, if the table was in between positions 7 and 8 (showing a 15), then turned slowly, by hand, clockwise, you might encounter a couple garbage numbers (higher than 8) until reading an 8. If you were to keep turning, you might get a couple more garbage numbers just after the 8 before getting a 15 again (showing that it is in between 8 and 9). Remember - the garbage numbers will always be higher than the real position number.

Suppose you were to choose a character table at random that was reading 15, begin turning it counterclockwise, and saw the following sequence: 15, 11, 7, 4, 9, 15. If you stopped and backed it up a bit to 4, you would be at position 4. You won't always encounter garbage numbers - just most of the time.

NOTE: The large turntable works exactly the same way, except there are 31 large table positions numbered 0 through 30, and the number 31 indicates "in between."

EXERCISE: After your show is installed and tested (when you have about 30 minutes while the store is closed), do the following to help familiarize yourself with some of the Show Adjustment Utilities functions and provide yourself with permanent alignment marks for your character turntables:

- 1) At the main menu, choose POSITION CHARACTERS IN FRONT. Press number 4 which is FATZ AND MITZI FRONT. As shown in diagram 3A (in the CHARACTER TURNTABLES section), this will position Fatz and Mitzi toward the front of the stage, and Billy Bob at the rear of the stage, directly in front of the big white circle on the back wall. At the same time, the small turntables have been positioned so that all three characters are facing directly forward (or close to it). All four tables are now in their "center" positions. The center position for a small table is exactly half way between the fully clockwise extreme of the table and the fully counterclockwise extreme. (The center position of the large turntable is Billy Bob to the back of the stage, roughly centered between left and right.) A small turntable, from extreme counterclockwise to extreme clockwise, rotates slightly more than one and one-half revolutions (about 550 degrees). Consequently, when a small table is at its center

position, the table can be turned roughly three-quarters of a revolution in either direction before hitting a mechanical stop mechanism that prevents the table from going any farther.

2) Press ESC to exit this screen, then at the main menu again, choose READ TURNTABLE L.E.D's. On the next screen, the names of the four air motor-drive turntables are listed along with a position number to the right. (For the moment, we aren't interested in center table.)

3) Assuming the characters' positions resemble the diagram 3A, each character table should be at position 7 or close to it. Having one person read the monitor and another on the center stage, start with Mitzi by verifying the center position of 7. If the readout isn't 7, move the table a little, one way or the other, until it does read 7. There should be a center mark or line on the character turntable itself, under the edge of the carpet, showing the front-and-center spot of the table - if not, make one with a permanent marker. (The center spot of a character table is where a line, exactly between the legs and perpendicular to the legs, hits the edge of the table in front of the character; thus, the term front-and-center.) Now, with help from the person watching the monitor, move the table one way until you reach the exact point where you lose the 7, then move the table the other way until you reach the other point where you lose the 7. Between these two points is the "range" of position 7, and exactly in the middle of the range is the exact front-and-center position. At the middle of the range, place a small, permanent mark on the stage (where it will be hidden under the carpet) directly across the gap from the center mark on the table, then label the stage mark "CTR-7" for center. (These marks will prove to be very useful should you ever need to perform repairs on a character turntable!)

NOTE: The average "range" of a position will be roughly two inches in length along the circumference of the table.

4) Spin Mitzi's table 3/4 revolution counterclockwise (slowly!) to find the range of position 0, locate the middle of the range (like above) and mark it "CCW-0."

5) Spin Mitzi's table 1 1/2 revolutions clockwise (slowly!) to find the range of position 14, locate the middle of the range (like above) and mark it "CW-14."

6) Repeat the process of marking the 0, 7, and 14 positions for Billy Bob and Fatz.

SHOW ADJUSTMENT UTILITIES

Show Adjustment Utilities are accessible from the main menu. The programs are menu-driven and easy to understand.

The two main purposes of the Show Adjustment Utilities are to help you properly adjust the speed of pneumatic movements, and to check the speed and positioning of the large turntable and character turntables.

After your show is installed and tested (when you have about 30 minutes while the store is closed), do the following to help familiarize yourself with some of the Show Adjustment Utilities functions and provide yourself with permanent alignment marks for your character turntables:

Turn on all power, turn on the computer, and go to the main menu. Select Show Adjust Utilities.

1) At the next menu, choose POSITION CHARACTERS IN FRONT. Press number 4 which is FATZ AND MITZI FRONT. As shown in diagram 3A (in the CHARACTER TURNTABLES section), this will position Fatz and Mitzi toward the front of the stage, and Billy Bob at the rear of the stage, directly in front of the big white circle on the back wall. At the same time, the small turntables have been positioned so that all three characters are facing directly forward (or close to it). All four tables are now in their "center" positions. The center position for a small table is exactly half way between the fully clockwise extreme of the table and the fully counterclockwise extreme. (The center position of the large turntable is Billy Bob to the back of the stage, roughly centered between left and right.) A small turntable, from extreme counterclockwise to extreme clockwise, rotates slightly more than one and one-half revolutions (about 550 degrees). Consequently, when a small table is at its center position, the table can be turned roughly three-quarters of a revolution in either direction before hitting a mechanical stop mechanism that prevents the table from going any farther.

2) Press ESC to exit this screen, then at the main menu again, choose READ TURNTABLE L.E.D's. On the next screen, the names of the four air motor-drive turntables are listed along with a position number to the right. (For the moment, we aren't interested in center table.)

[INFORMATION: For each character table, there are 15 readable positions, numbered 0-14, with number 15 reserved to indicate "in between." The center position is 7. Turning the table counterclockwise, the position numbers decrease to 0; turning the table clockwise, the numbers increase to 14. There will usually be "garbage" numbers just before and just after the true position

CHART 2A - VALVE BANK LAYOUT

BILLY BOB - FATZ - MITZI - BEACH BEAR - DOOK

Valve	Movement	Type	Movement OFF positions (starting positions)	
			cylinder / rotary	body movement
1	Mouth	cylinder	retracted	mouth closed
2	Lip	cylinder	extended	lip closed (up)
3	Head up **	cylinder	extended	NOT looking up
4	Head turn right	rotary	CCW	head turned left of center
5	Head tilt left	cylinder	extended	head level (NOT tilted)
6	Right wrist	cylinder	retracted	wrist straight (NOT bent)
7	Right elbow	cylinder	extended	arm straight (NOT bent)
8	Right arm twist	rotary	CW	palm facing in (NOT up)
9	Right arm raise **	cylinder	retracted	arm down
10	Right shoulder	cylinder	extended	arm down
11	Left wrist	cylinder	retracted	wrist straight (NOT bent)
12	Left elbow	cylinder	extended	arm straight (NOT bent)
13	Left arm twist	rotary	CCW	palm facing in (NOT up)
14	Left arm raise **	cylinder	retracted	arm down
15	Left shoulder	cylinder	extended	arm down
16	Head tilt right	cylinder	extended	head level (NOT tilted)
17	Body turn right **	cylinder	extended	body turned left of center
18	Body tilt left **	cylinder	extended	body vertical (NOT tilted)
19	Body tilt right **	cylinder	extended	body vertical (NOT tilted)
20	Knee bend	cylinder	extended	legs straight (NOT bent)
21	Ears (Mitzi)	cylinders	retracted	Mitzi ears straight up
21	Ears (Dook)	cylinders	extended	Dook ears down

** rebuildable cylinders

CHART 2B - VALVE BANK LAYOUT

LOONEY BIRD (character and window head)

Valve	Movement	Type	Movement OFF positions (starting positions)	
			cylinder / rotary	body movement
1	Mouth	cylinder	retracted	mouth closed
2	Lip	cylinder	extended	lip closed (up)
3	Head up **	cylinder	extended	NOT looking up
4	Head turn right	rotary	CCW	head turned left of center
5	Head tilt left	cylinder	extended	head level (NOT tilted)
6	Right wrist	cylinder	retracted	wrist straight (NOT bent)
7	Right elbow	cylinder	retracted	arm bent to chest
8	Right arm twist	rotary	CW	palm facing in (NOT up)
9	Head tilt right	cylinder	extended	head level (NOT tilted)
10	Right shoulder	cylinder	extended	arm down
11	Left wrist	cylinder	retracted	wrist straight (NOT bent)
12	Left elbow	cylinder	retracted	arm bent to chest
13	Left arm twist	rotary	CCW	palm facing in (NOT up)
14	Body turn right **	cylinder	extended	body turned left of center
15	Left shoulder	cylinder	extended	arm down
16	Head up (win)**	cylinder	extended	NOT looking up
17	Head turn (win)	cylinder	CCW	head turned left of center
18	Lip (win)	cylinder	extended	lip closed (up)
19	Mouth (win)	cylinder	retracted	mouth closed
20	Monitor	rotary	CCW	monitor facing audience

** rebuildable cylinders

(win) = window Looney head

VALVE BANK LAYOUT

VALVE #	MOVEMENT (ALL BUT LOONEY)	MOVEMENT (LOONEY ONLY)
1	MOUTH	MOUTH
2	LIP	LIP
3	HEAD UP	HEAD UP
4	HEAD TURN RIGHT	HEAD TURN RIGHT
5	HEAD TILT LEFT	HEAD TILT LEFT
6	RIGHT WRIST	RIGHT WRIST
7	RIGHT ELBOW	RIGHT ELBOW
8	RIGHT ARM TWIST	RIGHT ARM TWIST
9	RIGHT ARM RAISE	HEAD TILT RIGHT
10	RIGHT SHOULDER RAISE	RIGHT SHOULDER
11	LEFT WRIST	LEFT WRIST
12	LEFT ELBOW	LEFT ELBOW
13	LEFT ARM TWIST	LEFT ARM TWIST
14	LEFT ARM RAISE	BODY TURN RIGHT
15	LEFT SHOULDER RAISE	LEFT SHOULDER
16	HEAD TILT RIGHT	HEAD UP (WINDOW)
17	BODY TURN RIGHT	HEAD TURN (WINDOW)
18	BODY TILT LEFT	MOUTH (WINDOW)
19	BODY TILT RIGHT	LIP (WINDOW)
20	KNEES BEND	COMPUTER SWIVEL
21	EARS (DOOK AND MITZI)	

DIAGRAM 2C

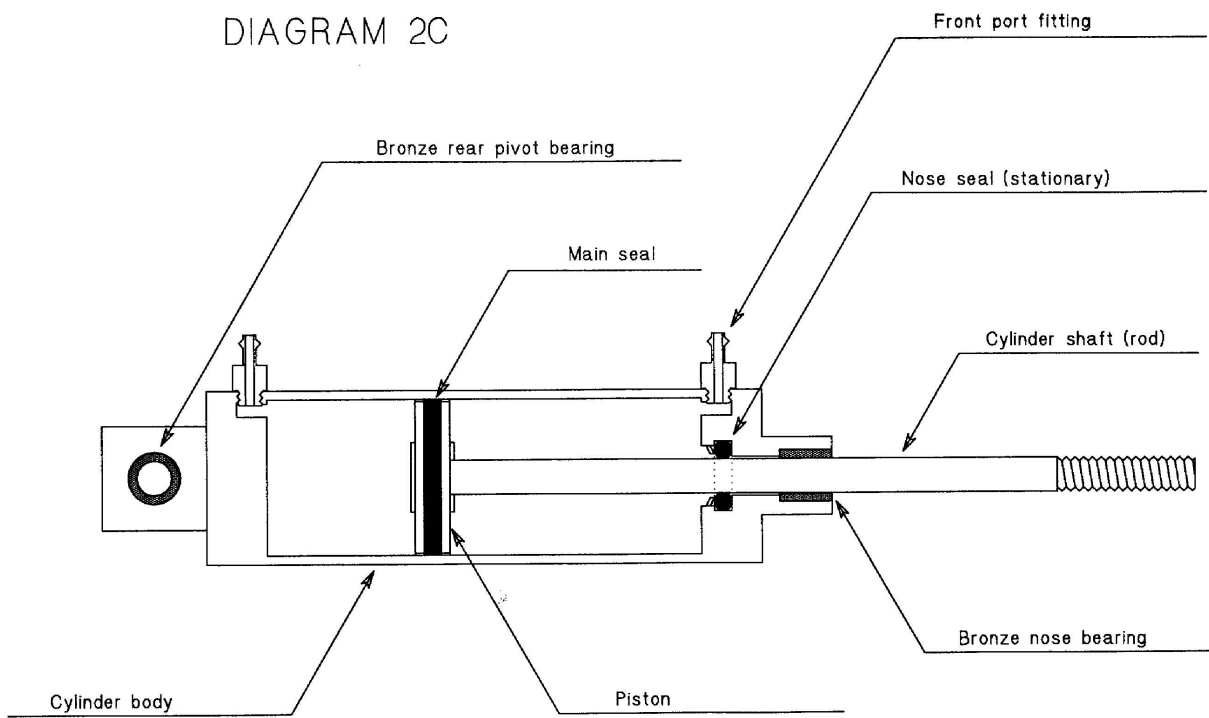

Cylinder bodies and shafts vary in size and shape, but all cylinders work essentially the same way.

Note: Rebuildable cylinders have removable rear caps. Maintenance-free cylinders do not.

Title: Typical Cylinder (cross-section view)	Tolerance (unless indicated):	Creative Engineering, Inc. 47 West Jefferson Street Orlando, Florida 32801
Date: 06/30/95		

DIAGRAM 2D

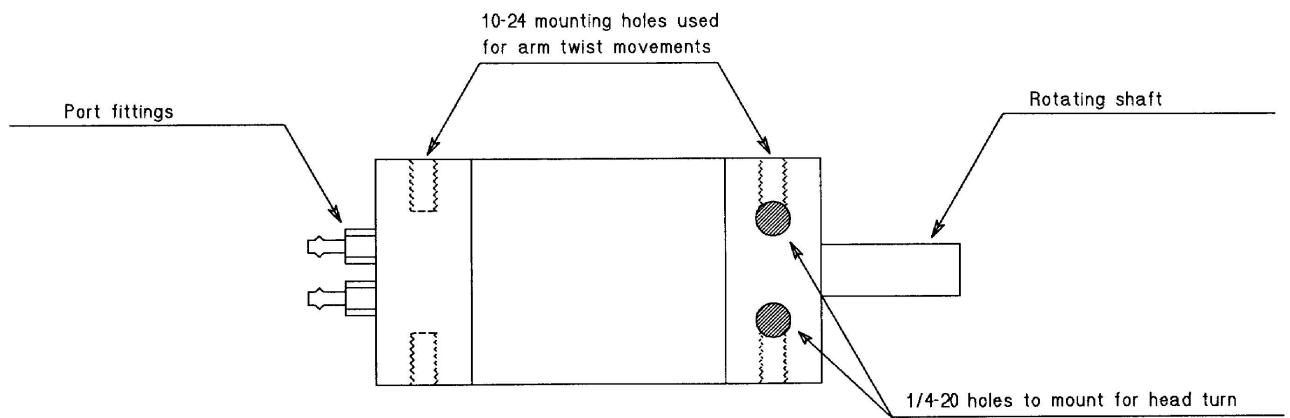

Rotary actuators are all the same size and shape; however, the three actuators used on each character are not interchangeable - the mounting holes and the number of degrees of rotation vary depending upon the character movement.

Title: Typical Rotary actuator	Tolerance (unless indicated):	Creative Engineering, Inc. 47 West Jefferson Street Orlando, Florida 32801
Date: 06/30/95	Scale: Full	

DIAGRAM 2E

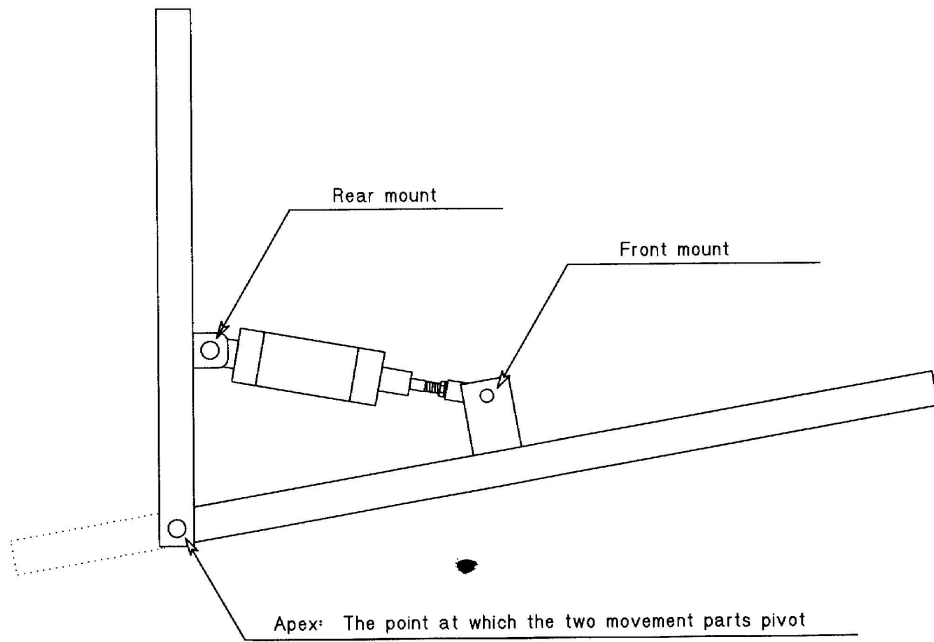

Title: Pivot Point example	Tolerance (unless indicated):	Creative Engineering, Inc. 47 West Jefferson Street Orlando, Florida 32801
Date: 06/14/95		

CHARACTER TURNTABLES

Each of the three center stage characters (Billy Bob, Mitzi, and Fatz) are attached to a small turntable, which allows each character to be independently positioned to face any direction at any time, regardless of the large turntable's position.

The character, the valve bank, and the bit-stripper are mounted in a wooden drum that is in turn mounted to a heavy-duty, hollow steel shaft. The shaft runs through an aluminum support mechanism called the "cradle," which is the three-inch square base with two vertical sides that attach it to the large turntable (see diagram 3B). Each character requires an air line to the valve bank, a power distribution cable to the bit-stripper, and a data cable to the bit-stripper. These three items come up through the hollow shaft into the drum, where they are held in place by strain-reliefs.

Under the cradle, on the lower end of the shaft, are two sprockets. The larger sprocket is attached by chain to the air motor that turns the character. The smaller sprocket is attached by chain in the other direction to a very large sprocket known as the "feedback gear." When the motor spins the turntable, the feedback gear is turned accordingly. The feedback gear has many sets of holes that, as it turns, pass between two circuit boards. Mounted on one board are infrared light emitters; mounted on the other board are infrared collectors. With everything properly aligned, the holes pass directly between the emitters and collectors. There are 15 unique combinations of holes that translate to 15 different turntable positions. Consequently, by monitoring the infrared boards, the computer knows where the turntable is and, when turning, which direction it is traveling, and when to stop.

These sprockets are preset at the factory and, aside from checking the chain tension (as described in the MAINTENANCE section), should never need adjustment. However, there are a number of areas of concern that should be fully understood by the store technician. The diagrams after this section will help clarify the following information regarding the character positions and the travel "limits" of the small turntables.

NOTE: With the exception of which direction each character faces relative to the large turntable, all three small turntables are mechanically identical by design and in operation.

CHARACTER POSITIONS:

The simplest way to understand the relationship of the small turntable positions is to put all three small tables AND the large table in their center positions. To do this, choose a time when the store is closed and then continue by doing the following: Go to the main menu and select Show Adjustment Utilities. At the next menu, choose POSITION CHARACTERS IN FRONT. Press number 4 which is FATZ AND MITZI FRONT. As shown in diagram 3A, this will position Fatz and Mitzi toward the front of the stage, and Billy Bob at the rear of the stage, directly in front of the big white circle on the back wall. At the same time, the small turntables have been positioned so that all three characters are facing directly forward. All four tables are now in their "center" positions. The center position for a small table is exactly half way between the fully clockwise extreme of the table and the fully counterclockwise extreme. (The center position of the large turntable is Billy Bob to the back of the stage, roughly centered between left and right.) A small turntable, from extreme counterclockwise to extreme clockwise, rotates slightly more than one and one-half revolutions (about 550 degrees). Consequently, when a small table is at its center position, the table can be turned three-quarters of a revolution in either direction before hitting a mechanical stop mechanism that prevents the table from going any farther. (For more information on positions, see the UTILITIES section.)

Whenever the computer sends a small turntable to a new position, it knows that there will be a small amount of drift (coasting) after the air motor is shut off; consequently, the motor is shut off a fraction of a second early to allow the turntable to coast to a stop, at or very near the desired position. As you can imagine, if the turntable speed (as defined under the UTILITIES section) is too fast, it will coast much too far and go beyond the target position; too slow, and the table won't even reach the target position. It's your responsibility, as with the large turntable, to check the small turntable speeds regularly.

THE LIMITS - SMALL TURNTABLE STOP MECHANISM:

ABOUT THE STOP MECHANISM - As mentioned above, each small turntable has a mechanical stop mechanism that prevents the table from turning too far in either direction. Mounted on the side of the cradle above the feedback gear is an "L" shaped aluminum bracket (see diagram 3B). Bolted to the bracket is a heavy-duty steel pin that extends straight down next to the hub of the feedback gear. On the hub of the feedback gear itself, there is a bolt (with an aluminum spacer and lock washer) tightly screwed into and extending from the hub. When a character is turned to either extreme position, the bolt contacts the steel pin, which stops the table from turning any farther. The bolt and pin are very strong but NOT unbreakable. If the turntable is traveling

too fast, it will coast considerably more than it should and will result in the bolt hitting the pin with enough force to break the bolt, the pin, or both. Keeping the small turntables properly adjusted will prevent any breakage.

BROKEN STOP - If any part of the stop mechanism is broken, you should stop the show as soon as possible to avoid any further damage, and administer repairs. Before doing repairs, you will have to determine if the character is still in sync ("sync" is short for synchronization), and determine what caused the table to hit the stop so hard. But first, a little about "sync."

ABOUT SYNCHRONIZATION (SYNC):

There is a direct relationship between the small turntable and the feedback gear. The exact position of the turntable is determined by the exact position of the feedback gear. When the turntable and the feedback gear are in perfect sync, the position information sent to the Big Important Board is correct. As a result, when the Big Important Board "thinks" the table is at (for instance) its center position, the table actually IS at its center position. If, however, the table and feedback gear get OUT of sync, the feedback gear will continue to send position information to the Big Important Board, but the ACTUAL position of the table will be altogether different and unpredictable.

HOW DOES IT HAPPEN?:

There is only ONE way for the large table to get out of sync. The table must travel too far in either direction (go past the extreme clockwise or extreme counterclockwise position), which can only occur if the stop-bolt or stop-pin is broken. This can happen if the turntable speed is too fast and slams into the stop, or if a person manually spins the turntable (too fast/too hard) until it hits the stop, causing breakage. Regardless of how it happens, if the table spins PAST the normal stop point (in either direction), the circuit boards that straddle the feedback gear will begin reading holes that don't correctly correspond to the character's position. At this point, if a show is run, the turntable will likely turn, BUT the table and the feedback gear are no longer in sync.

could this be a mistake? Do they mean a "small turntable"?
Mm 7/23/09

To go into greater detail, the gear on the hollow steel shaft and the feedback gear have different numbers of teeth. The feedback gear is larger (60 teeth) than the hollow-shaft gear (36 teeth). Consequently, the two gears do not have a 1-to-1 ratio. The actual ratio is 5-to-3 to allow the turntable to travel about 190 degrees MORE than one complete revolution while the feedback gear makes LESS than one revolution.

If the small turntable goes past a normal stop point, the table and gear will be OUT of sync by 72 degrees OR MORE. So, the characters will always be facing the wrong direction. EVEN WORSE, the two wires that go up through the hollow shaft to the bit-stripper board will get twisted far beyond normal and could break. If the table is out of sync, stop the show immediately and do the following:

Step 1) SAFETY FIRST:

Disconnect the air line that feeds the large turntable air motor. Disconnect the air line that feeds the character air motors. You will need to get under the large turntable for inspection and repairs, and certain corrective measures might cause the tables to move suddenly if air pressure is still applied to the air motors.

Step 2) MOVING THE LARGE TURNTABLE:

Manually position the large table so that the character that needs work is next to a spot where you can get under the stage.

CAUTION: Be absolutely certain that you are turning the large turntable the right direction. You must not allow the table to contact the limit switch. If you are unfamiliar with the large turntable operation and its "limit" switch, read the LARGE TURNTABLE section before going any farther.

Step 3) INSPECTION:

Look carefully at the wires that go up through the hollow shaft. These wires are secured to the end of the cradle and are originally set to have a lot of slack (droop) between the end of the cradle and the hollow shaft (basically along side the air line). If the wires appear to be excessively twisted (compared to the other characters), make a note of which direction they are twisted, as you will NOT want to spin the character any further in that direction.

Step 4) VERIFYING THE SYNC:

Your small turntables should have center marks (as described in the UTILITIES section). The goal is to align the small turntable center mark with the mark on the large turntable, then check to see if the feedback gear is reading "center" as well. Simply rotate the small table one way or the other (watch the wires) until the center marks align. Next, on the computer, go to the main menu, and select Show Adjustment Utilities. At the next menu choose READ TURNTABLE L.E.D'S. Now, on the next screen, locate the name of the character you are working on and note the

number next to it. The range of possible numbers is 0 to 15. Numbers 0 through 14 (on the computer screen) correspond to the 15 readable turntable positions. Number 15 (on the screen) indicates that the infrared readers are between holes. The center position of a character is 7. If your character's center marks are aligned and the readout is 7, the turntable is in sync - skip down to Step 5. If the readout is not 7, read OUT OF SYNC below.

OUT OF SYNC - If the center marks are aligned and the readout is not 7, you must rotate the table one complete turn until the center marks align once again. The only criteria for determining which direction to turn the table is the amount of twist in the wires. Choose the direction that is more friendly to the wires, then go ahead with rotating the table one complete revolution.

Note: While you are turning the table, have someone watch the readout to make sure the numbers are changing as the table spins. This ensures that the signals from the infrared boards are reaching the Big Important Board. If the numbers don't change while the table is moving, go to the NO DATA TO / FROM TURNTABLES section now.

After rotating the table one turn and aligning the center marks again, check the readout for 7. If the readout is 7, skip down to Step 5. If the readout is not 7, you will need to repeat this process of turning the table one complete revolution at a time (in the SAME direction) until the readout is 7. In any event, the maximum number of revolutions to put the table back in perfect sync is four revolutions. When the center marks are aligned and the readout is 7, go to Step 5.

Step 5) BACK IN SYNC:

Now that the turntable is back in sync, you need to repair the stop mechanism before the table is turned any more. If the stop-pin broke, simply mark where the old pin is tightened in the bracket's slot, and replace it with the new pin. If the stop-bolt broke, locate the stop-bolt hole (which is now at its farthest point away from the pin, meaning, it is on the other side of the cradle from the stop-pin). Remember, the hole you are looking for is 180 degrees away from the stop-pin, NOT the hole that is roughly 90 degrees away. When you've located the hole, you will need to remove the broken-off end of the bolt still in the hole, using either needle-nose pliers or, if necessary, an Easy Out tool. Replace the bolt/washer/spacer combination EXACTLY as it originally was, using a 5/16-24 x 3/4 inch socket head cap screw, a "high collar" lock washer, and the 1/4 inch aluminum spacer. When properly replaced, the end of the bolt should contact the pin, but NOT hit the upper infrared board as it passes by.

Step 6) FINAL CHECK:

If you haven't already done so, read the UTILITIES section in order to fully understand references to numbered positions of the small turntable.

- A) Align the center marks one more time and check the readout for number 7.
- B) Rotate the table clockwise to the position 14 mark, then continue turning slowly and note how far past the mark the table goes before stopping.
- C) Rotate the table fully counterclockwise to the position 0 mark, then continue turning slowly and note how far past the mark the table goes before stopping.
- D) The amount of travel between the mark and the stop is the "end zone." Both end zones should be the same distance, give-or-take a half inch. If one end zone is longer than the other, you will need to adjust the stop-pin by loosening it, sliding it in the adjustment slot of the bracket, and retightening the pin. (You'll probably need to hold the pin with a pair of ViseGrips to keep it from turning.)
- E) When the end zones are equal, the table is ready.

Step 7) PUTTING THINGS BACK:

Reconnect the air line to the large turntable air motor and the air line to the character air motors. Go back to the adjustment menu on the computer, choose POSITION CHARACTERS IN FRONT, and press number 4 which is FATZ AND MITZI FRONT. Compare to diagram 3A. If everything is correct, return to the main menu, and turn off the computer.

Step 8) RUNNING THE SHOW:

Follow the normal procedures for starting up the system, and run a show.

DIAGRAM 3A

Large turntable CENTER position

Billy Bob is REAR and center.

All characters facing forward

Note: This position is # 16

● = Front-and-center point of turntable

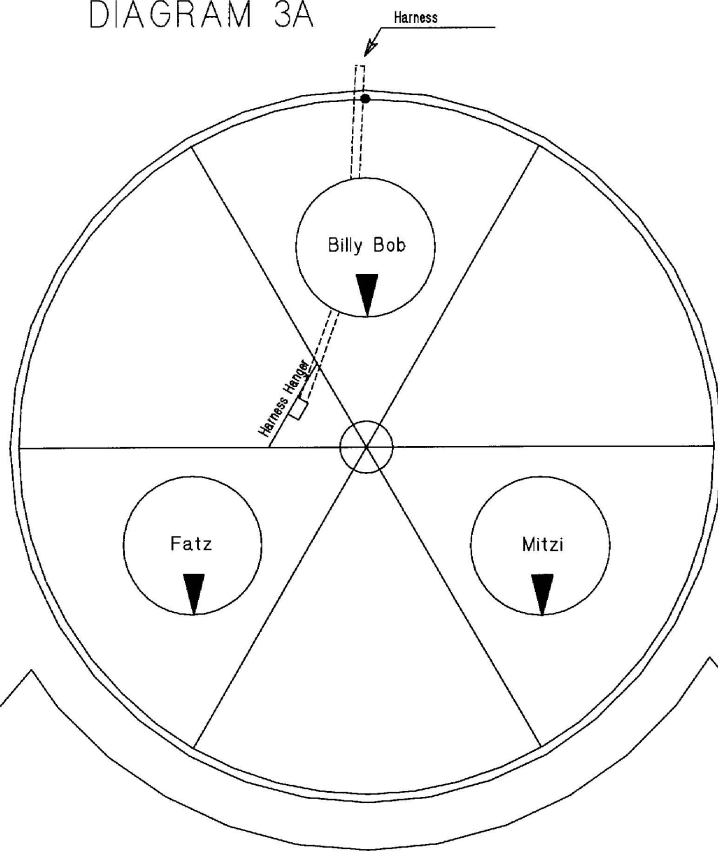

Title: Fatz and Mitzi front (Utilities: Position Characters)	Tolerance (unless indicated):	Creative Engineering, Inc. 47 West Jefferson Street Orlando, Florida 32801
Date: 10/24/95 (O.F.)		

DIAGRAM 3B

NOTE: For clarity purposes, the chains, wires, and hoses are not shown in this drawing.

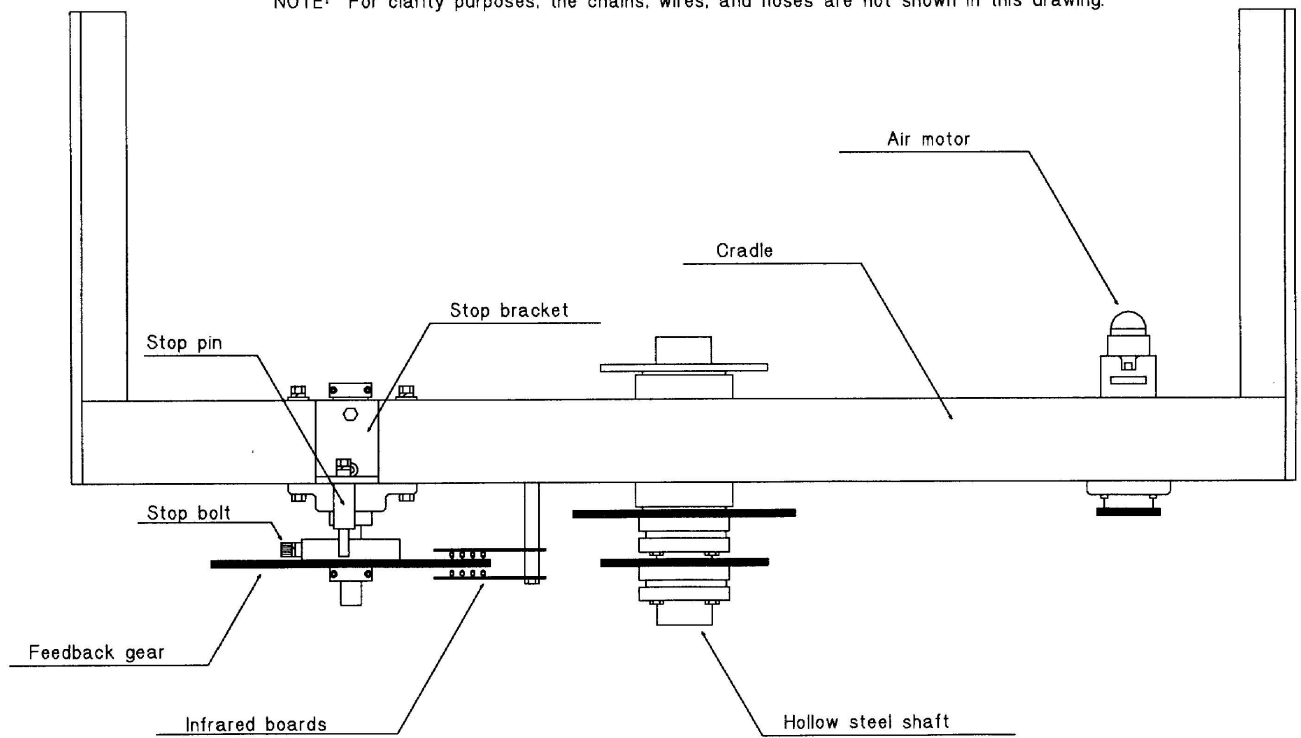

Title: Cradle	Tolerance (unless indicated):	Creative Engineering, Inc. 47 West Jefferson Street Orlando, Florida 32801
Date: 05/08/95		

LARGE TURNTABLE

The large turntable (center stage) functions similarly to the character turntables, yet on a much larger scale. The turntable carries the three center stage characters - Billy Bob, Fatz, and Mitzi. Suspended beneath the turntable midway between Billy Bob and Mitzi is the main harness that provides air and electrical power to the turning table. This harness is shown in dashed lines in the diagrams that follow this section.

The table is turned by a large air motor located on the back of the stage. Mounted to the air motor shaft is a drive wheel and tire that runs on diamond plate attached to the perimeter of the turntable. To keep the tire from slipping on the diamond plate, there is an air cylinder that presses the motor/tire assembly against the diamond plate. There is a small, adjustable pressure regulator with a gauge attached to the cylinder itself. The pressure gauge should read 40 to 50 p.s.i. when the show is running.

Under the center of the turntable is the steel pedestal that supports much of the table's weight and houses the main shaft and bearings on which the table spins (see diagram 4F). On the pedestal is a small sprocket. Mounted on one of the spokes of the turntable is a shaft with a larger sprocket known as the feedback gear. The two sprockets are attached by chain. When the turntable spins, the feedback gear is turned accordingly. The feedback gear has many sets of holes that, as it turns, pass between two circuit boards. Mounted on one board are infrared light emitters; mounted on the other board are infrared collectors. With everything properly aligned, the holes pass directly between the emitters and collectors. There are 31 unique combinations of holes that translate to 31 different turntable positions. Consequently, by monitoring the infrared boards, the computer knows where the turntable is and, when turning, which direction it is traveling, and when to stop.

These sprockets are preset at the factory and should never need adjustment; however, there are a couple areas of concern that should be fully understood by the store technician. The diagrams after this section will help clarify the following information regarding the travel "limits" of the large turntable.

As shown in diagram 4A, when the computer sends the table fully clockwise, Billy Bob is front-and-center. As shown in diagram 4B, when the table is sent fully counterclockwise, Billy Bob travels beyond the front-and-center position and ends up closer to the big screen TV. During a show, whenever the computer sends the table to a new position, it knows that there will be a certain amount of drift (coasting) after the air motor is shut off; consequently, the motor is shut off a fraction of a second

early to allow the turntable to coast to a stop, at or very near the desired position. As you can imagine, if the turntable speed (as defined under the UTILITIES section) is too fast, it will coast much too far and go beyond the target position; too slow, and the table won't even reach the target position. It's your responsibility, as with the character turntables, to check the large turntable speed regularly.

IMPORTANT: The large turntable DOES NOT have a mechanical stop mechanism to prevent the table from going beyond the extreme clockwise position or extreme counterclockwise position. Instead the table is equipped with a limit switch that, when triggered, immediately shuts off all air to the large turntable motor and temporarily "kills" the large table, meaning it will no longer move at all on its own (see diagram 4F). This limit switch is mounted on the aluminum stage spoke next to the feedback gear shaft. There is a pin extending from the feedback gear shaft that comes in contact with the limit switch if the table travels too far in either direction. IF the table is traveling too fast and/or, for any other reason, the table travels too far in either direction, the limit switch will be triggered and the air motor shut down. In such event, it is critically important that the following procedures be used to correct the situation:

Step 1) **QUALIFIED PEOPLE ONLY:**

DO NOT allow any unqualified person to touch the turntable, e.g., a customer or employee that thinks giving the stage a "push" will fix the problem. In all likelihood, the problem will be compounded instead of cured. Please make sure that there is a "hands off" policy in place for this unlikely event.

Step 2) **SAFETY FIRST:**

Turn off the computer. This will prevent shows from running while you are seeing to the needs of the large turntable.

CAUTION: Do not get under the stage during any procedure in this section.

Step 3) **DETERMINING THE DIRECTION OF TRAVEL:**

YOU MUST determine which direction the table was traveling when the limit switch was impacted. This is done by noting two factors. First, where is Billy Bob located and, second, which way is the main harness wrapped around the pedestal? These can be easily determined by comparing your stage to the diagrams 4C and 4D. Diagram 4C shows the approximate positions of Billy Bob and the harness if the table traveled too far clockwise. Diagram 4D shows the approximate positions when the table travels too far counterclockwise. **DO NOT** rely on Billy Bob's position alone.

ALWAYS check the position of the main harness too, as it will ALWAYS TELL THE TRUTH. (NOTE: If the positions of your Billy Bob and the main harness DON'T resemble one of the two diagrams (4C and 4D), proceed directly to the next section entitled "LARGE TURNTABLE SYNC PROBLEM ?").

Step 4) MOVING TURNTABLE AWAY FROM LIMIT SWITCH:

TOO FAR CLOCKWISE - If the turntable has gone too far clockwise, push the turntable counterclockwise until Billy Bob is front-and-center and the harness is lying as shown in diagram 4A. This puts the table into the normal operating area and moves the pin off of the limit switch, returning air pressure to the motor. Read the CAUTION's below and go on to Step 5.

TOO FAR COUNTERCLOCKWISE - If the turntable has gone too far counterclockwise, push the turntable clockwise until Billy Bob is front-and-center and the harness is lying as shown in diagram 4E. This puts the table into the normal operating area and resets the limit switch, returning air pressure to the motor. Read the CAUTION's below and go on to Step 5.

⚠ CAUTION: DO NOT run a show after manually pushing the large turntable without first completing this section.

CAUTION: Be extremely careful not to push the table the wrong way. If the stage is manually pushed too far in the WRONG direction in error, the pin that contacts the limit switch will eventually go completely PAST the limit switch, allowing the switch to reset which restores air pressure to the motor. If this happens, the relationship between the turntable and the feedback gear (which tells the computer where the table is) is now completely out of sync. ("sync" is short for synchronization.) When the show runs, the large table will likely turn, BUT the characters will always be facing in a direction they shouldn't be. Another problem, even more important, is that the main harness can get wrapped MORE than once around the pedestal - a situation that can cause SEVERE damage to the harness and turntable (see LARGE TURNTABLE SYNC PROBLEM ?).

Step 5) PRESSING THE RESET BUTTON:

When the RESET button is pressed, the Big Important Board instructs the large turntable to turn counterclockwise until it finds the first set of readable holes on the feedback gear (the character turntables will be resetting at the same time). Under normal circumstances, the table will only have to move less than 10 inches before finding the next set of holes, taking less than 1 second of time. The turntable will stop turning, the system will be properly "reset," and you're ready for Step 6.

NOTE 1 - However, if the turntable travels more than about 3 feet counterclockwise without the infrared boards detecting a set of holes, which is unusual, the table will reverse and begin turning clockwise BACK toward the original position, searching the area again for a set of holes. If the search is successful, the table will stop before even getting back to the original position. When the holes are located, the table will stop turning, the system will be properly "reset," and you're ready for Step 6.

NOTE 2 - Though very unlikely, IF the turntable searches counterclockwise and then resorts to clockwise (as described above) and STILL fails to read a set of holes, the table will stop near to, or even PAST, the original position, which is much too far to travel without finding any holes, and indicates a problem. The turntable will stop turning altogether and the Big Important Board will go into a 20-40 second time-out. At the end of the 20-40 seconds, the Big Important Board will try again. It will automatically start the entire search process over, the equivalent of pressing the RESET button again.

Step 6) IS THE TURNTABLE RESET OR IS IT WAITING TO TRY AGAIN?

After the turntable stops moving, simply wait to see if the Big Important Board starts to search again within 40 seconds. If the table does NOT start moving again, skip down to CHECKING RESULTS. If the table DOES start moving again, read SEARCHING AGAIN below.

SEARCHING AGAIN - If the table begins moving again, wait for it to complete its 2nd attempt to find readable holes and comes to a complete stop. Again, WAIT 40 seconds to see if it starts a 3rd search. If the table does NOT start moving again, skip down to CHECKING RESULTS. If it starts a THIRD search, there is something wrong and you will need to intervene to stop the process. To avoid getting stuck in this "loop," shut down the ENTIRE system. As long as Billy Bob was properly positioned front-and-center prior to pressing the RESET button, there is only one logical explanation for endless searching - the signals from the infrared boards are not reaching the Big Important Board. Go to the NO DATA TO / FROM TURNTABLES section.

CHECKING RESULTS - If 40 seconds passes without the table moving again by itself, it is probably reset. PLEASE, don't run a show just yet. First, check the turntable positions by doing the following: Turn on the computer (it should have been off). Go to the main menu, and select Show Adjustment Utilities. Next, choose ADJUST TURNTABLES. Select BIG TABLE CENTER. This should send Billy Bob to the back of the stage, roughly in the center (pay no attention to which direction Billy Bob is actually facing). Next, select BIG TABLE CW. This should turn the large turntable clockwise and send Billy Bob to the front-and-center position, give or take a few inches.

If Billy Bob ends up in the correct position both times, go on to Step 7. If Billy Bob does NOT end up in the correct position both times, go directly to the LARGE TURNTABLE SYNC PROBLEM ? section.

Step 7) RUNNING THE SHOW AFTER A "RESET"

Follow the normal procedures for starting up the system, and run a show. When the show is running, note the positions of the characters. If they are not where they should be and are facing the wrong direction, the large turntable is out of sync. See LARGE TURNTABLE SYNC PROBLEM ? section.

DIAGRAM 4A

Billy Bob is front and center.

Main harness is BARELY around the pedestal as shown.

Note: This position is referenced for RESET purposes in some sections of the manual.

● = Front-and-center point of turntable

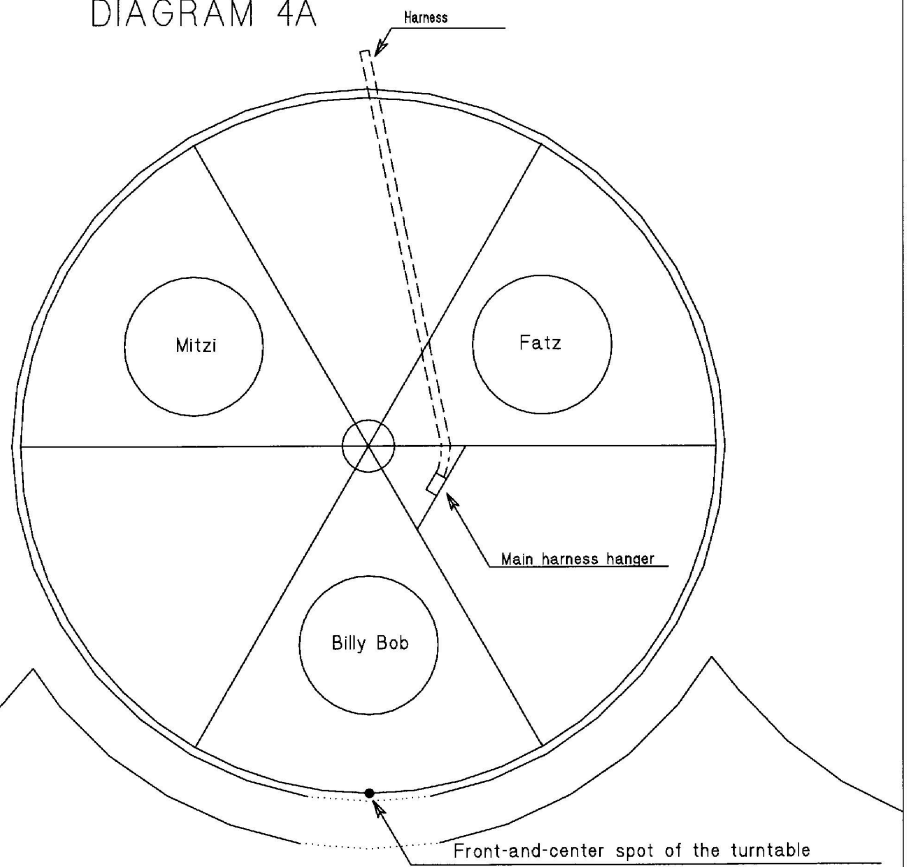

Title: Fully clockwise position (#30 front-and-center)	Tolerance (unless indicated):	Creative Engineering, Inc. 47 West Jefferson Street Orlando, Florida 32801
Date: 10/24/95 (O.F.)	Scale: Representational	

DIAGRAM 4B

Billy Bob is close to the large screen TV.

Main harness is wrapped about 3/4 of the way around the pedestal as shown.

● = Front-and-center point of turntable

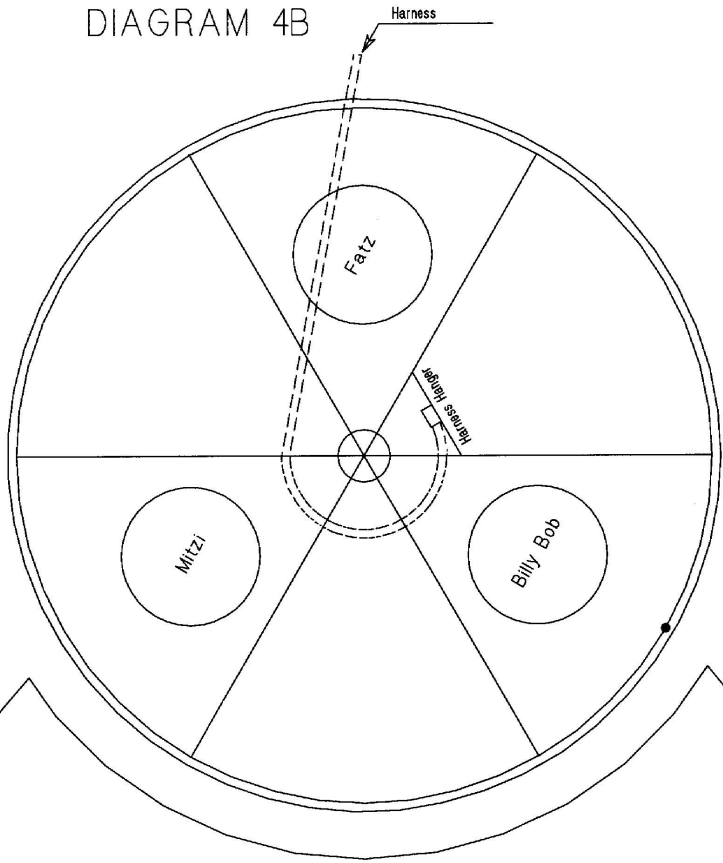

Title:	Fully counterclockwise position	Tolerance (unless indicated):	Creative Engineering, Inc. 47 West Jefferson Street Orlando, Florida 32801
Date:	10/24/95 (O.F.)		

DIAGRAM 4C

Turntable is beyond the normal extreme clockwise position.

Main harness is BARELY around the pedestal as shown.

● = Front-and-center point of turntable

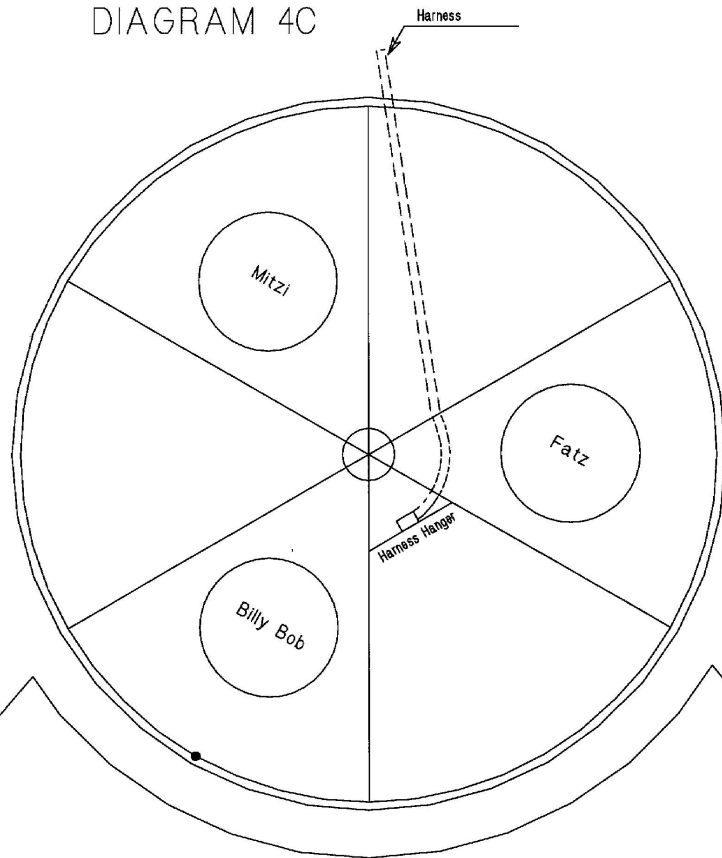

Title:	Beyond fully clockwise position, limit switch triggered	Tolerance (unless indicated):	Creative Engineering, Inc. 47 West Jefferson Street Orlando, Florida 32801
Date:	10/24/95 (O. F.)		

DIAGRAM 4D

Turntable is beyond the normal extreme counterclockwise position.

Main harness is wrapped about 7/8 of the way around the pedestal as shown.

● = Front-and-center point of turntable

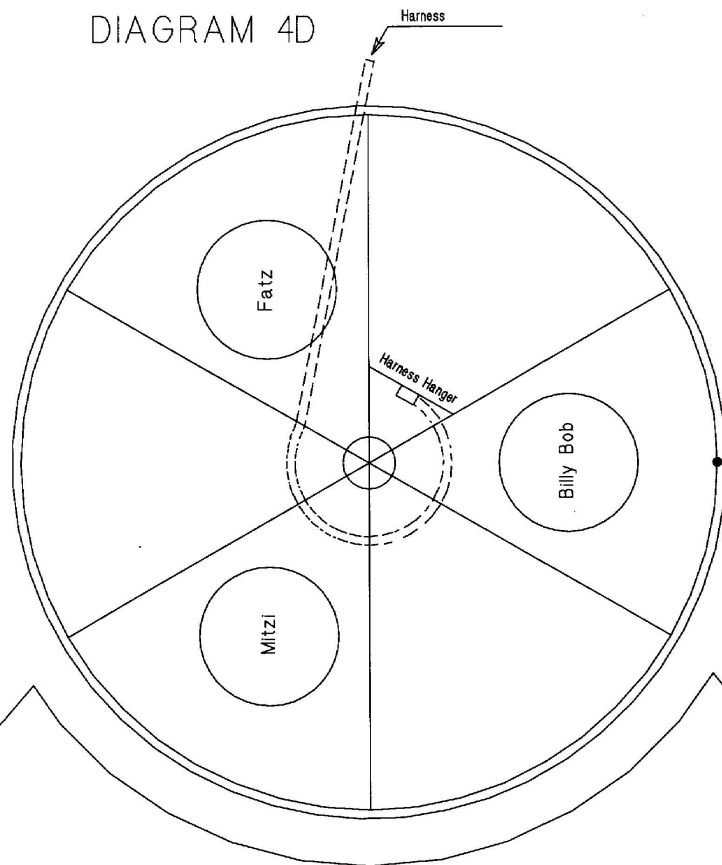

Title: Beyond fully counterclockwise position, limit switch triggered	Tolerance (unless indicated):	Creative Engineering, Inc. 47 West Jefferson Street Orlando, Florida 32801
Date: 10/24/95 (O.F.)	Scale: Representational	

DIAGRAM 4E

Billy Bob is front and center.
 (Don't confuse with diagram 4A)
 Main harness is PARTIALLY around
 the pedestal as shown.

Note: This position is referenced
 for RESET purposes in some sections
 of the manual.

● = Front-and-center point of turntable

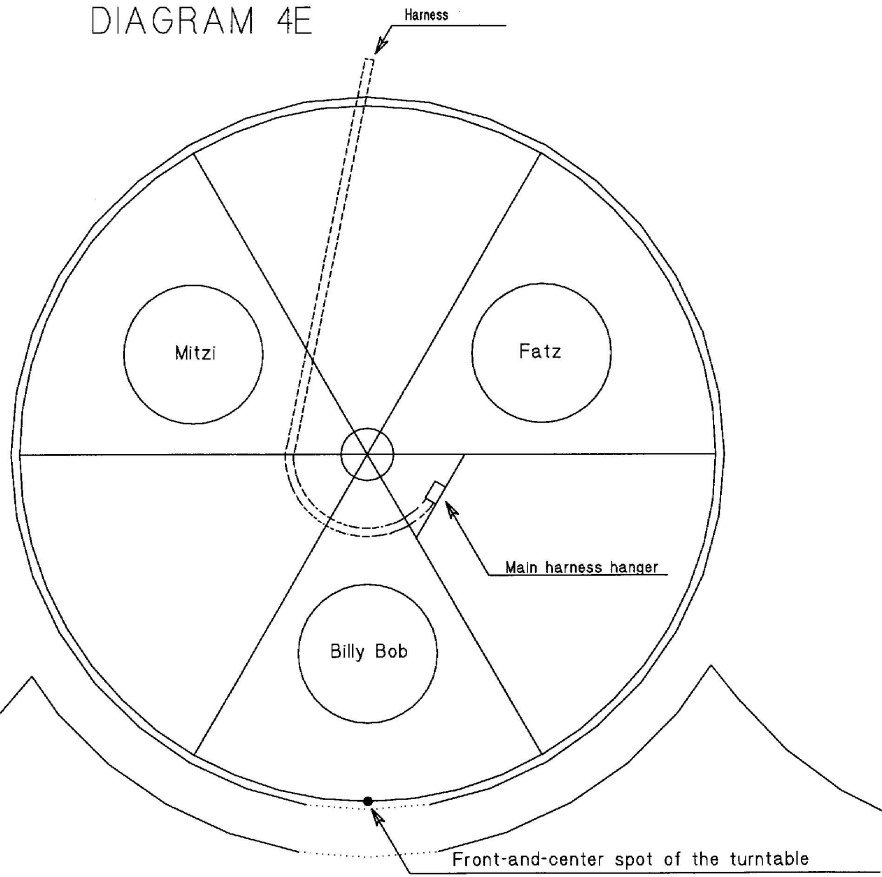

Title: #1 front-and-center	Tolerance (unless indicated):	Creative Engineering, Inc. 47 West Jefferson Street Orlando, Florida 32801
Date: 10/24/95 (O.F.)		

DIAGRAM 4F

NOTE 1: For clarity purposes, the chain and chain tensioner are not shown in this drawing.

NOTE 2: The chain tensioner (not shown) is a spring-loaded idler sprocket that prevents chain derailment. The tensioner must be in place at all times.

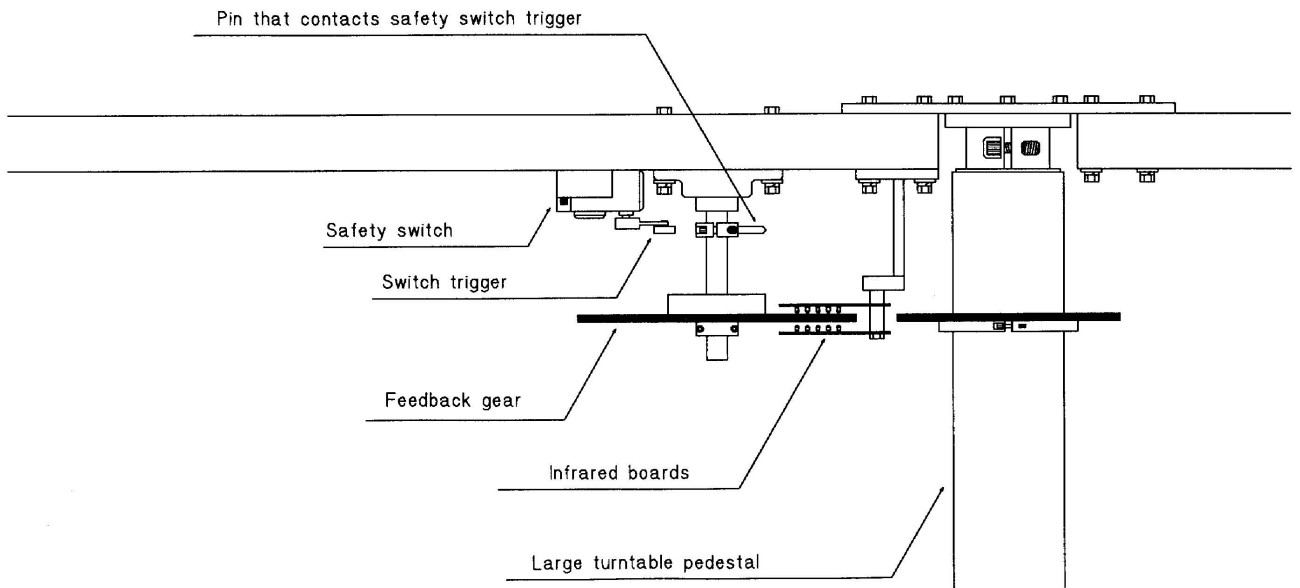

Title: Large turntable feedback assembly	Tolerance (unless indicated):	Creative Engineering, Inc. 47 West Jefferson Street Orlando, Florida 32801
Date: 06/15/95		

LARGE TURNTABLE SYNC PROBLEM ?

As noted in the last section, there is a direct relationship between the large turntable and the feedback gear. The exact position of the turntable is determined by the exact position of the feedback gear. When the turntable and the feedback gear are in perfect sync, the position information sent to the Big Important Board is correct. As a result, when the Big Important Board "thinks" the table is at position 12, the table actually IS at position 12. If, however, the table and feedback gear get OUT of sync, the feedback gear will continue to send position information to the Big Important Board, but the ACTUAL position of the table will be altogether different and unpredictable.

HOW DOES IT HAPPEN?:

There is only ONE way for the large table to get out of sync. First, the table must travel too far in either direction (go past the extreme clockwise or extreme counterclockwise position), triggering the limit switch. This can happen if the turntable speed is too fast and drifts into the switch, or if a person pushes the table until it hits the switch. In either case, the limit switch turns off air pressure to the turntable motor. Second, a person must manually push the table farther in the wrong direction (farther past the extreme position), causing the pin that contacts the limit switch to go completely PAST the switch, allowing the switch to reset, returning air to the motor. At this point, if a show is run, the turntable will likely turn, BUT the table and the feedback gear are no longer in sync.

To go into greater detail, the pedestal gear and the feedback gear have different numbers of teeth. The feedback gear is larger (60 teeth) than the pedestal gear (48 teeth). Consequently, the two gears do not have a 1-to-1 ratio. The actual ratio is 5-to-4 to allow the turntable to travel about 50 degrees MORE than one complete revolution while the feedback gear makes LESS than one revolution.

If the table is manually pushed far enough to go all the way PAST the limit switch, the table and gear will be OUT of sync by as much as 180 degrees. So, the characters will always be in the wrong positions and will always be facing the wrong way. EVEN WORSE, the main harness will get wrapped as much as TWICE around the pedestal. Even with slack in the harness, this situation can and PROBABLY WILL CAUSE DAMAGE to the turntable and/or harness. If the table is out of sync, stop the show immediately and do the following:

PUTTING THE TURNTABLE BACK IN SYNC:

Step 1) SAFETY FIRST:

Disconnect the air line that feeds the large turntable air motor. If you have not already turned off the computer, turn it off now. You may need to get under the large turntable for inspection, and certain corrective measures might cause the table to move suddenly if air pressure is still applied to the air motor.

Step 2) INSPECTION

Refer to diagrams 4A and 4B again. Keep in mind that these two diagrams clearly show the absolute most that the harness should be around the pedestal in either extreme position. In both diagrams, note that the harness is not wrapped "around" the pedestal at all. In diagram 4A, the harness hanger (the aluminum channel that pulls the harness around) doesn't even go beyond the front of the pedestal. In 4B, the harness hanger goes about 3/8 of a turn past the front of the pedestal.

Look under the turntable from behind the stage, remove any extra slack in the harness, and carefully note the lay of your harness in relation to the pedestal. If the harness is wrapped too much in one direction, the stage will need to be manually pushed (rotated) in the opposite direction as described below.

Step 3) MOVING THE TABLE:

WRAPPED TOO MUCH CLOCKWISE - If the harness is wrapped around the pedestal too much in the clockwise direction, then have someone push the turntable counterclockwise until Billy Bob is front-and-center (if, while pushing, the pin contacts the limit switch, keep pushing right on past it). The relationship between your harness and the pedestal should now resemble diagram 4A. If they do, skip down to Step 4. If your harness is NOT currently lying the same as pictured in the diagram, then your stage must have been MORE than one full revolution out of sync, and you will have to determine which way the turntable needs to be turned to get your table and harness to the positions in diagram 4A. (If your table was this far out of sync, take the time to carefully inspect the harness and where it connects to the hanger for damage.) When the table and harness are correctly set (diagram 4A), skip down to STEP 4.

WRAPPED TOO MUCH COUNTERCLOCKWISE - If the harness is wrapped around the pedestal too much in the counterclockwise direction, then have someone push the turntable clockwise until Billy Bob is front-and-center (if, while pushing, the pin contacts the limit switch, keep pushing right on past it). The relationship between your harness and the pedestal should now resemble diagram 4E.

If they do, skip down to Step 4. If your harness is NOT currently lying the same as pictured in the diagram, then your stage must have been MORE than one full revolution out of sync, and you will have to determine which way the turntable needs to be turned to get your table and harness to the positions in diagram 4E. (If your table was this far out of sync, take the time to carefully inspect the harness and where it connects to the hanger for damage.) When the table and harness are correctly set as (diagram 4E), go on to Step 4.

Step 4) PUTTING THINGS BACK:

Reconnect the air line to the air motor.

Step 5) PRESSING THE RESET BUTTON:

The procedures for this operation are fully described in the preceding section. Go to LARGE TURNTABLE section, Step 5.

NO DATA TO / FROM TURNTABLES

If you are reading this section, it's because you've determined that, for some reason, the position of a turntable is not being properly reported to the Big Important Board and on to the computer. To verify that this is the problem (if you haven't already done so), do the following test:

Turn on the computer, go to the main menu, and select Show Adjustment Utilities. Next, at the adjustment menu, choose READ TURNTABLE L.E.D.'s. On the next screen, find the name of the turntable in question and note the position number next to it. Have someone manually rotate the table while you watch the screen to see if the position numbers properly increase or decrease as the table moves.

GOOD READINGS - If the position numbers are reported accurately, then the infrared feedback system is fine, the data is reaching the Big Important Board intact, and the computer is interpreting the information correctly.

BAD READINGS - If the position numbers are NOT reported accurately (no change in number or erratic changes), then continue reading the information below.

- 1) Using the wiring diagrams in the COMPUTER / WIRING DIAGRAMS section, check the 24-pin and 26-pin connectors on the Big Important Board labeled Turntable Control and Show Play Card. Next, check the other end of the 26-pin cable where it connects to the Show Play Card in the computer (CAUTION: Make sure the computer is OFF anytime you are touching cables or cards in the computer.)
- 2) Disconnect the air line that feeds the large turntable before getting underneath.
- 3) Under the large table, check the other end of the 24-pin cable where it connects to the Large turntable interface board which is mounted on a cross-brace between Billy Bob and Fatz.
- 4) On the interface board, check all the other infrared connectors, paying close attention to the ones that relate to the table that isn't reading properly (consult the wiring diagram).
- 5) Finally, locate the feedback gear for the table in question and carefully inspect the infrared boards, the wire connectors, and the alignment of the boards relative to the feedback gear. Turn the table by hand and make sure the sets of holes pass directly between the infrared emitters and collectors. If any part of an infrared board has been damaged, it must be replaced.

SIDE TURNTABLES

The side turntables operate on a slightly different principle than any other movement in the show. The side tables use a system referred to as air-over-oil, and are the ONLY components of the show that use hydraulic oil as part of the movement itself.

A side turntable is controlled by a pneumatic valve like any other pneumatic movement; however, the pressurized air from the valve is not directed to the cylinder ports (in this case, a cable cylinder). Instead, the air is directed into the top of one of two oil reservoirs. The pressurized air entering the top port of one reservoir forces the oil in the reservoir to exit the bottom port which is piped to one end of the cable cylinder. This, of course, causes the cable cylinder's piston to move toward the other end of the cylinder where the oil is allowed to exit the cable cylinder. This exiting oil is forced in through the bottom port of the other reservoir, which, in turn, forces the air in the top of that reservoir to the air valve where it is exhausted to the muffler.

Though unlikely, it is possible for the oil, over time, to bleed by the main seals of the cable cylinder, thereby creating a situation where one reservoir has a greater-than-normal amount of hydraulic oil, leaving the other reservoir with less than normal. These oil levels, according to the MAINTENANCE section, should be monitored for just such condition. In the event the reservoirs become unbalanced, they have been designed with a by-pass line to allow oil to flow from one to the other via a shut-off valve. Needless to say, the by-pass valve should remain shut during normal use!

OIL LEVEL CORRECTION:

1) Note the level of oil in the reservoir closest to the back of the stage. Next, use the override toggle switch to turn the stage, and note the oil level in the other reservoir (which is now closer to the back of the stage). If either one shows less than 1/4 inch of visible oil, a balancing adjustment is probably necessary. There are many complicated ways to do make the adjustment and one easy way:

2) The easy way is to disconnect the air hose from the props valve bank that supplies the turntable cylinder reservoirs (this valve bank is mounted on the board that supports the turntable cable cylinder).

- 3) Manually rotate the side turntable until it is exactly half way through the 180 degree turn. Going under the table, look at the reservoirs and compare the oil levels. The levels should be equal and each reservoir should be half full. If not, continue on.
- 4) Using a hex key, loosen and remove the plug on the top of each reservoir.
- 5) Open the valve on the by-pass line and allow a few moments for the oil levels to balance between the reservoirs. When the levels are equal, note how full they are. Each reservoir should be close to (but NOT over) half full. If the levels are under half full, add a little prescribed oil to one of the reservoirs and wait for the levels to balance again. Continue adding oil until the levels are equal and just under half full.
- 6) Close the by-pass valve. REPEAT - Close the by-pass valve.
- 7) Replace and tighten the hex-key plugs.
- 8) When you're out from under the stage, reconnect the air line.
- 9) Cycle the stage several times and recheck the levels (air bubbles in the system can affect oil levels).

SPEED ADJUSTMENTS:

The speed at which the side turntable rotates is controlled by large flow controls, one for each direction. Remember: the flow control meters the speed that the oil (in this case) is allowed to exit the cable cylinder. The flow controls are in-line, near the ports of the cable cylinder. When properly adjusted, the side turntable should take eight (8) seconds to travel from one extreme to the other.

PROPS / LIGHTS

PROPS:

The props of the show are pneumatic movements other than those of the characters themselves. Of course, in actuality, the word "prop" could apply to anything, but for simplicity purposes, its easier to consider props to be the movements that are controlled by the three "props" valve banks.

EXCEPTION 1 - The side turntables are, in fact, controlled by the props valve banks, but they are discussed in a different section.

EXCEPTION 2 - The Looney Bird computer swivel is actually a "prop," but is controlled by Looney Bird's valve bank (see chart 2B in THE CHARACTER section).

The three props valve banks (listed by the valve numbers) are outlined on chart 6A at the end of this section. The props controller, which is the bit-stripper connected to the interface board, is outlined by LED number on chart 6B. (If your show is not a full three-stage show, then some of the listed props may not apply to your show.)

STAGE LEFT - The stage left props valve bank is mounted on the board that supports the stage turn cable cylinder and air-over-oil reservoirs. (Valve #1 turns the left stage). Valves #2 through #4 control the rabbit ears on top of the large screen TV box. These particular four movements each use a single-acting cylinder referred to by its brand name as a "Clippard" cylinder. Unlike a double-acting cylinder that requires pressurized air to the rear port to extend the cylinder and pressurized air to the front port to retract the cylinder, Clippard cylinders are, in their starting position, retracted by an internal spring and only have one air port at the rear of the cylinder to extend the shaft when pressurized. If you look at the valve bank you'll notice that the **B** ports of the valves that control the rabbit ears are plugged. Since the pressure from the valve's **B** port is normally used to return the cylinder to its starting position, these ports are not used with Clippards due to the internal return-spring. When the valve is shifted (movement ON), the valve's **A** port is pressurized, the air enters the rear of the Clippard, and the cylinder extends, compressing the spring. When the valve is unshifted (movement OFF), the valve's **A** port is no longer pressurized and the Clippard's internal spring retracts the cylinder. Looking at the valve bank, you'll also notice that each single air line from each valve has two flow controls instead of one. The flow control with the arrow pointing away from the valve bank meters the air going toward the cylinder when the movement is ON. The other flow control, with the arrow pointing toward the valve bank, meters the movement going OFF.

CENTER STAGE - The center stage props valve bank is normally located on the back of the stage, near the large turntable air motor. This valve bank controls the left and right (imitation) speakers and the curtains. The speaker cylinders are standard, double-acting cylinders, and the curtain cylinders are long-stroke, cable cylinders. The flow controls for all of the movements on this valve bank are located near the cylinders themselves.

STAGE RIGHT - The stage right props valve bank is mounted on the board that supports the stage turn cable cylinder and air-over-oil reservoirs. (Valve #1 turns the right stage). Valve #2 controls the hacienda window that opens to expose the Looney Bird head. Valve #3 operates the coconut that drops down and appears to hit Beach Bear on the head. Both of these props are actuated by long-stroke, double-acting cylinders mounted inside the hacienda wall behind Beach Bear.

The cables that power the three props valve banks come directly from the interface board mounted next to the props bit-stripper in the electrical panel box behind the stage (this is the box that has the override toggle switches).

LIGHTS:

As mentioned much earlier in the manual, the lighting bit-stripper is a standard bit-stripper board that has been slightly modified. All bit-strippers have a 26-pin connector and are normally designed to use pins 23-26 as common (+24vdc) and pins 1-22 to close the circuit (supply the ground) of the individual valve or, in the case of lights, solid-state relay. The lights bit-stripper has been modified to extend the normal 22 switches to 24 available switches. On the lights bit-stripper, only pins #25 and #26 are common (+24vdc).

From the lights bit-stripper, the 26-pin ribbon cable goes directly to the solid-state relay panel called the light "controller," mounted behind the stage. Inside the panel box are 24 relays. The lighting bit-stripper closes the low-voltage side of a relay which, instantly, closes the high-voltage (110vac) side of the relay, thereby turning on the light. Chart 6C shows the lights listed according the relay number.

NOTE: If your show is a full, three-stage show WITH karaoke, there will be two extra relays in the controller - one for the karaoke spot light and one for the applause sign. The 24vdc power to close these relays comes through a separate cable from the props bit-stripper (via the interface board to which the props valve banks are wired).

CHART 6A - VALVE BANK LAYOUT

PROPS VALVE BANKS - LEFT, CENTER, AND RIGHT STAGE

Valve	Stage-Left Bank	Type	Movement OFF positions (starting positions)	
			cylinder	prop movement
1	Stage-left turn	cable cyl.	n/a	large TV toward audience
2	Rabbit ear / top-left	Clippard	retracted	ear down
3	Rab. ear / top-right	Clippard	retracted	ear down
4	Rab. ear / bot.-left	Clippard	retracted	ear down
5	Rab. ear / bot. right	Clippard	retracted	ear down

Valve	Center Stage Bank	Type	cylinder	prop movement
1	Stage-left curtain	cable cyl.	n/a	curtain down
2	Center stage curtain	cable cyl.	n/a	curtain down
3	Stage-right curtain	cable cyl.	n/a	curtain down
4	Left speakers	cylinders	retracted	speaker cone pulled back
5	Right speakers	cylinders	retracted	speaker cone pulled back

Valve	Stage-Right Bank	Type	cylinder	prop movement
1	Stage-right turn	cable cyl.	n/a	Beach Bear toward audience
2 *	Hacienda window	cylinder	extended	window closed
3	Coconut drop	cylinder	retracted	coconut up in tree

* On this movement, there are two small, in-line pressure regulators. They are adjusted to lower the normal 80 psi down to about 25 psi.

PROPS VALVES

VALVE	MOVEMENT
1- SL	STAGE LEFT TURN
2- SL	RABBIT EAR- TOP LEFT
3- SL	RABBIT EAR- TOP RIGHT
4- SL	RABBIT EAR- BOTTOM LEFT
5- SL	RABBIT EAR- BOTTOM RIGHT
1- CTR	STAGE LEFT CURTAIN
2- CTR	CENTER STAGE CURTAIN
3- CTR	STAGE RIGHT CURTAIN
4- CTR	LEFT SPEAKERS
5- CTR	RIGHT SPEAKERS
1- SR	STAGE RIGHT TURN
2- SR	BEACH BEAR WINDOW
3- SR	COCONUT DROP

CHART 6B - PROPS CONTROLLER

LED#	Function	Valve bank	Valve #
1	Stage-left turn	SL	1
2	Rabbit ear / top-left	SL	2
3	Rabbit ear / top-right	SL	3
4	Rabbit ear / bottom-left	SL	4
5	Rabbit ear / bottom-right	SL	5
6	Left speakers	CS	4
7	Right speakers	CS	5
8	Stage-left curtain	CS	1
9	Center stage curtain	CS	2
10	Stage-right curtain	CS	3
11	Stage-right turn	SR	1
12	Hacienda window	SR	2
13	Coconut drop	SR	3
14 *	Applause sign		
15 *	Karaoke spot light		
16	Not used		
17	Not used		
18	Not used		
19	Not used		
20	Not used		

* Only used for shows with Karaoke. The wires from these two connectors (along with a common wire) are routed to two solid-state relays in the lighting controller.

SL = Stage-left CS = Center stage SR = Stage-right

PROPS CONTROLLER

LED OR DRIVER	BIT	OUTPUT OR FUNCTION	WIRE COLOR AND STAGE
1	42B	STAGE LEFT TURNTABLE	BROWN- SL
2	46B	RABBIT EARS TOP LEFT	RED- SL
3	47B	RABBIT EARS TOP RIGHT	ORANGE-SL
4	48B	RABBIT EARS BOTTOM LEFT	YELLOW-SL
5	49B	RABBIT EARS BOTTOM RIGHT	GREEN- SL
6	45B	SPEAKER LEFT	YELLOW-CTR
7	61B	SPEAKER RIGHT	GREEN- CTR
8	58B	STAGE LEFT CURTAIN	ORANGE-CTR
9	60B	CENTER STAGE CURTAIN	RED- CTR
10	59B	STAGE RIGHT CURTAIN	BROWN- CTR
11	41B	STAGE RIGHT TURNTABLE	RED- SR
12	43B	BBEAR WINDOW	WHITE- SR
13	44B	COCONUT DROP	GREEN- SR
14	82B	NOT USED	
15	83B	NOT USED	
16	84B	NOT USED	
17	89B	NOT USED	
18	90B	NOT USED	
19	91B	NOT USED	
20	92B	NOT USED	

CHECK THESE WIRE BY LOCKING THE MOVEMENTS ON FOR THAT MOVEMENT AND CONNECT THE WIRE TO THE TERMINAL. IF THAT IS NOT THE CORRECT WIRE THEN TRY ANOTHER ON THAT CABLE. ALL THE BLACK WIRES FROM EACH CABLE (SL,CTR,SR) SHOULD BE CONNECTED TO ONE OF THE +24V COMMONS ON THE INTERFACE BOARD.

CHART 6C - LIGHTING CONTROLLER

Relay	Light (Lit object)	Type	Gel color
1	Note #1 - yellow note	neon	n/a
2	Note #2 - blue note	neon	n/a
3	"Rock-afire" neon	neon	n/a
4	Note #3 - pink note	neon	n/a
5	"Explosion" neon	neon	n/a
6	White circle on backdrop wall	spot	green
7	Heart on backdrop wall	spot	blue
8	Top-left speaker	spot	purple
9	Top-right speaker	spot	yellow
10	EQ (fake) on backdrop wall	spot	blue
11	Bottom-right speaker	spot	purple
12	Yellow star on backdrop wall	spot	red
13	Bottom-left speaker	spot	blue
14	Organ (fake) on backdrop wall	spot	blue
15	Stage-right floor spot	spot	yellow
16	Stage-left floor spot	spot	blue
17	Stage-left character spot	spot	none
18	Stage-right character spot	spot	none
19	Center stage left character spot	spot	none
20	Center stage center character spot	spot	none
21	Center stage right character spot	spot	none
22	Note #4 - purple note	neon	n/a
23	Looney Bird window light	bulb	n/a
24	Dook window (on house)	bulb	n/a
25 *	Applause sign	bulbs	n/a
26 *	Karaoke spot	spot	none

* For Karaoke shows only

LIGHT CONTROL PROM

LED OR DRIVER	BIT	OUTPUT OR FUNCTION
1	106B	NOTE #1
2	107B	NOTE #2
3	108B	ROCKAFIRE NEON
4	119B	NOTE #3
5	56B	EXPLOSION NEON
6	109B	WHITE CIRCLE- GREEN GEL
7	110B	HEART- BLUE GEL
8	111B	TOP LEFT SPEAKER- PURPLE GEL
9	112B	TOP RIGHT SPEAKER- YELLOW GEL
10	113B	EQ. RACK- BLUE GEL
11	114B	BOTTOM RIGHT SPEAKER- PURPLE GEL
12	115B	YELLOW STAR- RED GEL
13	116B	BOTTOM LEFT SPEAKER- BLUE GEL
14	117B	ORAGN- BLUE GEL
15	57B	STAGE RIGHT FLOOR SPOTS
16	74B	STAGE LEFT FLOOR SPOTS
17	101B	STAGE LEFT SPOT
18	102B	STAGE RIGHT SPOT
19	103B	CENTER STAGE LEFT SPOT
20	104B	CENTER STAGE CENTER SPOT
21	105B	CENTER STAGE RIGHT SPOT
22	118B	NOTE #4
23	97B	LOONEY BIRD LIGHT
24	98B	DOOK WINDOW

POSITION OF COLOR LIGHTS FOR STAGE

CIRCUITS 1-4 ARE TO BE PLACED IN A LINE ABOUT 3 FEET FROM THE FRONT OF THE STAGE. NUMBER ONE TO BE ON THE STAGE LEFT END AND NUMBER 4 ON THE STAGE RIGHT END. CIRCUITS 5-9 ARE TO BE PLACED IN A LINE ABOUT 6 FEET FROM THE FRONT OF THE STAGE WITH 5 ON THE LEFT AND 9 ON THE RIGHT. THEY ARE TO BE DIRECTED AS FOLLOWS:

#1 TO THE CENTER WHITE CIRCLE OF BACK WALL	- GREEN GEL
#2 TO THE HEART ON THE WALL	- BLUE GEL
#3 TO THE TOP LEFT SPEAKER	- PURPLE GEL
#4 TO THE TOP RIGHT SPEAKER	- YELLOW GEL
#5 TO THE EQ RACK ON STAGE LEFT	- BLUE GEL
#6 TO THE BOTTOM RIGHT SPEAKER	- PURPLE GEL
#7 TO THE YELLOW STAR ON THE BACK WALL	- RED GEL
#8 TO THE BOTTOM LEFT SPEAKER	- BLUE GEL
#9 TO THE ORGAN ON STAGE RIGHT	- BLUE GEL

SIDE STAGE GELS ARE TO BE YELLOW ON STAGE RIGHT AND BLUE ON STAGE LEFT. THEY SHOULD BE MOUNTED DIRECTLY ABOVE SIDE STAGES AND POINTED SO HAS TO FILL AS MUCH OF THE STAGE AS POSSIBLE.

STROBE SHOULD BE MOUNTED IN THE MIDDLE OF CENTER STAGE AND WIRED TO THE TURNTABLE BOARD WITH A HOT LINE FOR POWER FEED.

NEON AND NOTES CAN BE PLUGGED INTO A TWO AND FOUR GANG BOX AND WIRED TO THE LIGHT CONTROLLER.

SPOTLIGHTS (1-5) SHOULD BE WIRED TO THE CONTROLLER WITH 5 HOTS, 3 NEUTRALS AND ONE GROUND. IRIS PLATES SHOULD BE DRILLED AFTER MOUNTING AND FOCUSING LIGHTS.

RAE93 BIT CHART

CHARACTERS

	MITZI	BBOB	FATZ	DOOK	BBEAR	LB LAB	LB WIN
MOUTH	01T	21T	41T	61T	21B	1B	16B
LIP	02T	22T	42T	62T	22B	2B	17B
HEAD DOWN	03T	23T	43T	63T	23B	3B	18B
HEAD TURN	04T	24T	44T	64T	24B	4B	19B
HEAD TILT LEFT	05T	25T	45T	65T	25B	5B	
HEAD TILT RIGHT	16T	36T	56T	76T	36B	9B	
EARS	105T			106T			
LEFT BODY TILT	18T	38T	58T	78T	38B		
RIGHT BODY TILT	19T	39T	59T	79T	39B		
LEFT WRIST	11T	31T	51T	71T	31B	11B	
RIGHT WRIST	06T	26T	46T	66T	26B	6B	
LEFT ELBOW	12T	32T	52T	72T	32B	12B	
RIGHT ELBOW	07T	27T	47T	67T	27B	7B	
LEFT ARM TWIST	13T	33T	53T	73T	33B	13B	
RIGHT ARM TWIST	08T	28T	48T	68T	28B	8B	
LEFT ARM RAISE	14T	34T	54T	74T	34B		
RIGHT ARM RAISE	09T	29T	49T	69T	29B		
LEFT SHOULDER	15T	35T	55T	75T	35B	15B	
RIGHT SHOULDER	10T	30T	50T	70T	30B	10B	
KNEE BEND	20T	40T	60T	80T	40B		
BODY TURN RIGHT	17T	37T	57T	77T	37B	14B	

SERVOS

EYES RIGHT	83T	89T	95T	101T	65B	52B
EYES LEFT	82T	88T	94T	100T	64B	51B
EYES DOWN	85T	91T	97T	103T	67B	54B
EYES UP	84T	90T	96T	102T	66B	53B
LIDS CLOSE	86T	92T	98T	104T	73B	55B
LIDS OPEN	81T	87T	93T	99T	63B	50B

PROPS

COMPUTER SWIVEL	20B
LARGE TV	75B
SMALL TV	76B
BBEAR WINDOW	43B
COCONUT DROP	44B
SPEAKER LEFT	45B
SPEAKER RIGHT	61B
RABBIT EARS TOP LEFT	46B
RABBIT EARS TOP RIGHT	47B
RABBIT EARS BOTTOM LEFT	48B
RABBIT EARS BOTTOM RIGHT	49B

TURNTABLES

CENTER STAGE	68-72B
MITZI	77-80B
BILLY BOB	85-88B
FATZ	93-96B
STAGE RIGHT	41B
STAGE LEFT	42B

CURTAINS

STAGE LEFT CURTAIN	58B
STAGE RIGHT CURTAIN	59B
CENTER STAGE CURTAIN	60B

LIGHTS

STAGE LEFT SPOT	101B
STAGE RIGHT SPOT	102B
CENTER STAGE LEFT	103B
CENTER STAGE CENTER	104B
CENTER STAGE RIGHT	105B

ORGAN LIGHTS	106B
COLOR LIGHTS #1	109B
COLOR LIGHTS #2	110B
COLOR LIGHTS #3	111B
COLOR LIGHTS #4	112B
COLOR LIGHTS #5	113B
COLOR LIGHTS #6	114B
COLOR LIGHTS #7	115B
COLOR LIGHTS #8	116B
COLOR LIGHTS #9	117B
STAGE RIGHT FLOOR SPOTS	57B
STAGE LEFT FLOOR SPOTS	74B

STAR STROBES	118B
LOONEY BIRD LIGHT	97B
DOOK WINDOW	98B
STROBE	81B
ROCKAFIRE NEON	108B
EXPLOSION NEON	119B

CONTROLS

STOP	99B
REWIND	100B

THE CHARACTERS

The characters in your show are designed and built with two things in mind: long life and minimal maintenance. However, it is important that you realize up front that those two things go together - the long life is dependent upon your attention to the maintenance. If it were possible to build a moderately-priced, maintenance-FREE character containing all the movements our characters do, we would do it. The fact is that all mechanical devices in the world always have, and likely always will, require some type of maintenance. All products with moving parts, from roller skates to space shuttles, will undergo a certain amount of normal wear and tear over time. Equally so, all such products, when NOT properly maintained, will usually suffer from poor performance and/or breakdowns.

Because your characters require some routine attention, it's important that you understand the basic design of the individual character. The component parts that make up the mechanical structure of the character are made of various materials: mostly aluminum, steel, and plastics. The plastic parts are used for several reasons. They are lighter in weight, less expensive to make (usually), and work very well in friction-producing areas like pivot points.

Aside from the masks and costumes/clothing of each character which are obviously quite different for each; for the most part, the characters are mechanically identical. The servo movements in the head, which control the eyes and eyelids, are the same in every head. With the exception of Looney Bird, the first 20 pneumatic movements of each character are also the same. (Mitzi and Dook have an optional 21st pneumatic movement for the ears.) Looney Bird has only 15 pneumatic movements, so the other 5 valves of Looney Bird's valve bank are used to control the pneumatics in the Looney Bird "window head" (in the window next to Beach Bear), and Looney Bird's monitor swivel.

The first three columns of charts 2A and 2B (following this section) list the cylinders and rotary actuators for each character, named according to their movement. Listed along with each movement is the type (cylinder or rotary actuator) and valve number of each movement. The valve number indicates which valve of the character's valve bank actuates the movement. Chart 2A applies to all characters except Looney Bird. Looney Bird's movements are listed on Chart 2B.

As mentioned above, your Mitzi and/or Dook may have an active 21st valve controlling the ears. As for Looney Bird, due to the constraints of being behind his desk, five of the standard movements are not used for him. These five eliminated movements are both *arm raises*, both *body tilts*, and the *knee bend*.

CYLINDERS AND ROTARY ACTUATORS:

The pneumatic actuators used for the movements vary by way of design and construction. Most of the movements are driven by linear actuators that have cylindrically-shaped bodies with a piston rod extending from one end that travels straight out (extended) and straight back (retracted), and are simply referred to as "cylinders." However, there are three movements that use a non-linear actuator: *head turn right*, *right arm twist*, and *left arm twist*. These movements rely on "rotary actuators" which are box-shaped pneumatic devices used to twist things to which they are attached. Rotary actuators have a length of shaft extending from one end that is specifically designed to NOT move in or out at all, at any time. The shaft, instead, rotates a certain number of degrees, e.g., a 90 degree rotary actuator turns 1/4 turn from stop-to-stop.

LUBRICATION - The cylinders and rotary actuators are lubricated in two ways. They are pre-lubricated during assembly at the factory and are, thereafter, lubricated by the automatic oilers attached to the main air manifold. These oilers automatically inject a very small amount of hydraulic oil into the air as the air passes through. (There are also oilers on the manifold to lubricate the air going to the "air motors" that rotate the character turntables and a separate oiler for the air motor that drives the large turntable.) The cylinders and actuators are designed to cycle hundreds of thousands of times, or even more, before requiring service.

CYLINDERS - A typical cylinder consists of a round body of equal diameter from one port to the other (the port is the threaded hole into which the hose fitting is screwed), and a threaded shaft extending from one end that is attached to a piston that travels within the cylinder (see diagram 2C). When air pressure is applied to hose attached to one port, the piston is forced toward the other port, which is un-pressurized. The speed of the piston movement is controlled by limiting the rate at which the air is allowed to escape through the hose attached to the un-pressurized port. The mechanism used to limit the rate is called a "flow control" (described later).

In each cylinder there are two seals. The seals are specially-made rubber O-rings that do two things: they prevent the piston and shaft from making direct contact with the inside walls of the cylinder body; and, at the same time, prevent air from leaking past the piston (called "blow-by") or between the shaft and the inside of the nose of the cylinder. If either seal becomes excessively worn or damaged, the cylinder will need to be repaired or replaced. Charts 2A and 2B denote rebuildable cylinders with ** after the name. The other cylinders are maintenance-free and cannot be rebuilt (they don't come apart); therefore, they must be replaced.

number - this is completely normal. For example, if the table was in between positions 7 and 8 (showing a 15), then turned slowly, by hand, clockwise, you might encounter a couple garbage numbers (higher than 8) until reading an 8. If you were to keep turning, you might get a couple more garbage numbers just after the 8 before getting a 15 again (showing that it is in between 8 and 9). Remember - the garbage numbers will always be higher than the real position number. Suppose you were to choose a character table at random that was reading 15, begin turning it counterclockwise, and saw the following sequence: 15, 11, 7, 4, 9, 15. If you stopped and backed it up a bit to 4, you would be at position 4. You won't always encounter garbage numbers - just most of the time.]

3) Assuming the characters' positions resemble the diagram 3A, each character table should be at position 7 or close to it. Having one person read the monitor and another on the center stage, start with Mitzi by verifying the center position of 7. If the readout isn't 7, move the table a little, one way or the other, until it does read 7. There should be a center mark or line on the character turntable itself, under the edge of the carpet, showing the front-and-center spot of the table - if not, make one with a permanent marker. (The center spot of a character table is where a line, exactly between the legs and perpendicular to the legs, hits the edge of the table in front of the character; thus, the term front-and-center.) Now, with help from the person watching the monitor, move the table one way until you reach the exact point where you lose the 7, then move the table the other way until you reach the other point where you lose the 7. Between these two points is the "range" of position 7, and exactly in the middle of the range is the exact front-and-center position. At the middle of the range, place a small, permanent mark on the stage (where it will be hidden under the carpet) directly across the gap from the center mark on the table, then label the stage mark "CTR-7" for center. (These marks will prove to be very useful should you ever need to perform repairs on a character turntable!)

NOTE: The average "range" of a position will be roughly two inches in length along the circumference of the table.

4) Spin Mitzi's table $3/4$ revolution counterclockwise (slowly!) to find the range of position 0, locate the middle of the range (like above) and mark it "CCW-0."

5) Spin Mitzi's table $1\ 1/2$ revolutions clockwise (slowly!) to find the range of position 14, locate the middle of the range (like above) and mark it "CW-14."

6) Repeat the process of marking the 0, 7, and 14 positions for Billy Bob and Fatz.

Further text, detailing the various functions of the UTILITIES programs, is under development.

The most common reason for premature cylinder wear is "side-load." Side-load is a condition where, for one reason or another, the piston shaft is pushed or flexed sideways while the piston is moving. This side-load causes the shaft to rub abnormally hard against one area of the inside of the nose of the cylinder. Since the nose seal is in this area, it too is worn at an accelerated rate at that particular spot where the shaft is being forced to rub on it more than normal. Due to mechanical leverage, if side-load occurs, the piston (and seal) will also be forced to rub abnormally hard against the inside surface of the cylinder body. As you might imagine, under side-load conditions, it won't take long for the seals of a cylinder to deteriorate and begin leaking. Even worse, if the side-load is severe enough, the piston and shaft can actually scrape the interior surfaces of the cylinder, causing the movement to stick or stop altogether. Some hints regarding side-load are discussed later in this section.

ROTARY ACTUATORS - A typical rotary actuator has a box-shaped body and a short shaft extending from one end (see diagram 2D). The ports are next to each other on the end opposite to the extended shaft. Since the purpose of the rotary actuator is to turn or twist whatever is attached to the shaft, the shaft runs from one end to the other and rides on needle bearings at each end of the actuator. These needle bearings are used because side-load is practically guaranteed in rotary movements - that is, the rotary actuator is designed to handle it.

The interior of the rotary actuator is difficult to appreciate without actually seeing it. The shaft, inside the central part of the actuator, has two vanes, one opposite the other. The vanes are rectangular-shaped plates that are attached to the shaft and seal against the curved interior surface of the actuator. When air pressure is applied to hose attached to one port, pressure builds up behind one vane and forces the shaft to rotate, as the air on the other side of the vane is allowed to escape out the other port, which is un-pressurized. The speed of the rotation is controlled by limiting the rate at which the air is allowed to escape through the hose attached to the un-pressurized port. The mechanism used to limit the rate is called a "flow control" (described later). Rotary actuators aren't particularly strong; consequently, they are only used in movements that don't require a lot of heavy lifting (opposing gravity).

Though not very powerful, rotary actuators are very reliable - they should function for years and years on end. The seals in the rotary actuator are very complex and [without experience] difficult to properly service. If a rotary actuator should malfunction, it is recommended that you order a new or rebuilt one. (The tolerances within rotary actuators are such that attempts to rebuild them can result in wasted time and money.)

VALVE BANKS:

As mentioned earlier, there are 20 movements on the average character. Charts 2A and 2B list the movements by name. The charts also denote the type of mechanism used (cylinder or rotary actuator), which cylinders are rebuildable, and which valve number applies to each movement. Each character has a "valve bank" which is actually a base board with two banks of valves interconnected with air hoses and wires. The valve banks for all characters are plumbed and wired alike with the exception of Looney Bird (compare charts 2A and 2B). Each individual valve is shifted by an electric solenoid that is bolted directly to the valve and has two black wires connecting the solenoid to a small PC board mounted between the two banks of valves. The solenoids operate on 24vdc and are triggered by the bit-stripper, which in turn receives data from the computer.

NOTE: Each valve also has an override button to allow for manual operation during maintenance. It's a small, white, recessed button on the outside of the valve that can be pushed with a small screwdriver to manually shift the valve.

The valves are used to control the air flow to and from the cylinders (and rotaries). Since all pneumatic movements rely on pressurized air, each valve bank is supplied by a main air line with a female quick-connect that's attached to a "T" connector on the valve bank hoses. At that point, the air splits off in opposite directions and feeds both banks of valves at the main "inlet" port at the end of each bank. Similarly, each bank has a main "exhaust" port (next to the inlet) where the air comes back out of the banks and routed to another "T" connector attached to a muffler to dampen the noise.

The simple responsibility of the valve is to make the cylinder (or rotaries) move. When the valve is at rest, the pressurized air (80 psi) is directed out the **B** port of the valve, through the air hose, to one port of the cylinder. If this happens to be the front port of the cylinder, the piston inside would be forced toward the rear end of the cylinder until it stops. The air that was behind the piston escapes out the rear cylinder port, through the other air hose, to the **A** port of the valve, where it is vented directly the muffler. The cylinder, retracted in this case, is now in its "starting position." To keep things uncomplicated, when the valve is unshifted (at rest) and the cylinder is in its starting position, the movement is said to be OFF. When the movement is ON, everything is just the opposite - the solenoid is energized, the valve is shifted, and now the functions of the valve ports are reversed. The pressurized air is now directed out the **A** port, through the hose, to the rear port of the example cylinder. The piston is forced to the nose-end of the cylinder and the air in front of the piston escapes out the front port, down the hose, to the valve's **B** port which is now vented to the muffler.

POSITIONS:

For each movement, there are two positions: movement OFF (starting position) and movement ON. As you can imagine, if the air hoses to a cylinder get reversed, the movement's positions will be backwards. For example, when the hoses between valve number 12 and the left elbow cylinder are properly connected, the OFF position of the cylinder is "extended" (the shaft is out as far as it goes) and the elbow is not bent. The ON position has the cylinder "retracted" and the elbow is bent. If the hoses were to be accidentally reversed (during repair or maintenance), the elbow would start out bent and then straighten when the movement is turned ON - obviously backwards.

The last two columns of charts 2A and 2B show the movement OFF positions of the cylinders/rotaries as well as the OFF positions of the character's actual body movement. When ALL the movements are OFF, and everything is working properly, the character will be in proper "stance." Knowing the proper stance will make it easier to spot potential problems before they progress. The actual position of the cylinder or rotary itself is only helpful when the costume is removed, since they are otherwise not visible.

NOTE: When working directly with a cylinder, using the override button on the valve to cycle the cylinder a couple times makes it easier to determine the retracted and extended positions. The positions of a rotary actuator are clockwise (CW) and counterclockwise (CCW), determined by cycling the movement and looking at the rotary from the shaft end (the shaft pointing directly toward you).

FLOW CONTROLS:

A flow control is a small mechanical device used to control or "meter" the flow of air through a hose in one direction only. ALL pneumatic movements in the show have two flow controls - one for each direction of the movement (including curtains, props, and turntables). All flow controls, regardless of size or shape, work the same way. They have an adjustable screw to control the flow of air going one direction, and a bypass valve that allows air to flow the other direction completely unrestricted. The entire purpose of the flow control is to control the speed of a movement by metering the speed of the air going through the air hoses. Flow controls are absolutely necessary for smooth, fluid movements in the characters, stages, curtains, etc. Your first guess might be that the flow control meters the air going toward the cylinder when during the movement - but it doesn't. The flow control on the hose carrying air toward the cylinder (or rotary, air motor, etc.) allows the air to pass through completely unrestricted. The flow control on the hose carrying air AWAY from the cylinder (back to the valve bank) is doing the metering, that is, controlling the flow of air.

Understanding flow controls, and how to adjust them, is critical regarding the function of your show. There are basically three styles of flow controls, described below:

1) Built-In: Many of the valves in the character valve banks have both flow controls built right in, one flow control for each direction. To be exact, valves 3 through 17 of each character valve bank have built-in flow controls (the rest do not). Being built-in, the only thing visible and accessible to you are the adjustment screws located on the outside of the valve just below the override button. The two screws are consistent with standards; that is, turning the screw in (CW) decreases the flow and turning the screw out (CCW) increases the flow. The screw on the left controls the speed of the ON movement, and the screw on the right controls the OFF movement.

2) FC-32: FC-32 flow controls are in-line flow controls used to control character movements that don't have built-in flow controls. FC-32's are roughly one inch square and about a 1/4 inch thick with a thumb screw extending from one side. In addition, there is an arrow imprinted on the side to show in which direction the air is metered. These arrows are always pointing away from the cylinder and toward the valve bank. Movements that utilize FC-32's are listed here, along with the physical location of the FC-32's.

--- Billy Bob, Fatz, Mitzi, Beach Bear, Dook ---

#1	Mouth	-	behind neck block
#2	Lip	-	" " "
#18	Body tilt left	-	directly before cylinder
#19	Body tilt right	-	" " "
#20	Knee bend	-	" " "
#21	Ears (Dook/Mitzi)	-	behind neck block

--- Looney Bird Only ---

#1	Mouth	-	behind neck block
#2	Lip	-	" " "
#18	Lip (window head)	-	behind neck block (window head)
#19	Mouth (window head)	-	" " " "
#20	Monitor swivel	-	under desk near swivel rotary

FC-32's are not normally marked to show which is for the ON and which is for the OFF movement, but simple trial-and-error will indicate which is which during adjustment.

3) High-volume: High-volume flow controls are not used on the characters themselves; rather, they are used for movements that require large volumes of air which include the curtain cylinders, side turntable cylinders, large turntable air motor, and character turntable air motors. They are in-line like FC-32's but much larger, barrel-shaped, and have a locking nut on the thumb screw.

MOVEMENT SPEEDS:

Adjusting the speed of each movement is accomplished through adjusting the two flow controls for each movement. As mentioned above, most flow controls are built-in, while others are actually inside the character near the cylinder. The characters have been designed, for the most part, to move at the same speed as a human might. Some movements are faster than others. For instance, short movements like the *mouth*, *lip* and *wrists* will be rather quick since the parts being moved are short or very light - just as with humans. Movements with long parts or heavy lifting duties will be slower, like *arm raises*, *shoulder raises*, and *body tilts*. If a movement is too slow, it will look unrealistic and affect the choreography of the show. Even worse, if the movement is too fast, not only will it look bad and not match the other characters, but it can cause severe damage to the character.

Built in to each end of the cylinder (inside) are rubber bumpers (or buffers) that prevent the piston from making metal-to-metal contact with the cylinder housing at the end of each stroke. And since the rubber is slightly compressible, it also serves to cushion the piston to a stop during the last few thousandths-of-an-inch of travel. Though not visible to the naked eye, that little bumper also cushions the stopping of the arm, or head, or whatever is being moved. All in all, the movement should be relatively silent when it reaches the end of the travel, i.e., no banging or clacking noises that indicate that it is stopping too abruptly because it's traveling too fast. If the piston and, for instance, the arm to which it's attached are travelling faster than normal, when the piston slams into the bumper, the cushioning ability of the small bumper will be momentarily overpowered, causing the piston and the arm to stop instantly causing the banging noise (and possibly damage). This condition is often referred to as "slamming," and is completely undesirable. Movements that "slam" not only look bad, but shorten the life expectancy of the parts involved.

Analogy: Imagine a sheet of rubber about 1/2 inch thick on a wooden coffee table. A bowling ball is suspended by a rope three feet above, then lowered at a steady, moderate rate (let's say one foot per second) until it contacts the rubber mat and stops. The rubber would be able to absorb the impact of the ball. There would be relatively little noise (if any), and the table would not be damaged. Now, with the bowling ball back up to three feet above the table, this time cut the rope. By the time the ball hits the rubber, it's velocity will be roughly 13.8 feet per second. The rubber cannot absorb the impact, so the force of the ball is transferred to the table - end of table! This example is a bit extreme, but the point should be clear - the speed of each character movement can only be so fast until the momentum of the moving parts overpowers the bumper, which causes slamming.

SPEED ADJUSTMENTS- The most reliable way to correctly adjust the speed of each movement is to use the supplied Adjustment Video Tape (still being developed as of 08/01/95). This tape automatically cycles the movements of each character while showing a properly adjusted character on the TV screen that your character should match. The instructions for using the tape are under separate cover and come with the tape itself. Keeping the characters properly adjusted is important to maintain the choreography of the show. All *arm raises* should be set the same, all *body tilt* speeds the same, etc. Remember - a movement that is too slow looks bad; a movement that is too fast not only looks bad, but can cause expensive damage.

PIVOT POINTS:

For every character movement involving a cylinder, there are three pivot points - the apex, the front mount, and the rear mount (see diagram 2E). The apex is the point where the two involved body parts are actually connected to each other. For example, the apex of an *elbow* movement is the elbow joint itself - the pivoting joint where the upper arm meets the lower arm to form a hinge. The apex of the *body tilt* movements is the large universal joint in the center of the character. The front mount is where the cylinder shaft rod end (or clevis) meets the lower arm near the wrist area. The rear mount is, of course, the point where the rear of the cylinder attaches to the upper arm. If any one of the three points is not free to pivot properly, the movement will stick or seize instead of moving smoothly and fluidly.

Though the pivot points of the seventeen cylinder-based movements of a standard character differ in size and shape, there are only four "types" of pivot points used: shaft-and-bearing, floating pin, ball joint, and universal joint. All four are briefly outlined below:

1) Shaft-and-bearing: There are four movements that utilize this type of pivot for their apex. The left and right *shoulder raise* cylinders each attach to a lever that is permanently affixed to a shaft that spins in the plastic shoulder block (the bearing) and rotates the arm upward when the movement is ON. Next is the *body turn right* movement. The shaft that extends downward from the large universal joint in the center of the character spins inside oil-impregnated bearings pressed into the two-piece plastic hip block, allowing the entire body above the hip to rotate left or right. The last one is the *knee bend*. The apex of the *knee bend* is where the lower leg bars pass through the plywood base at the character's feet. There are two foot plates attaching each leg to the plywood. Each leg (with pressed-in oil-impregnated bearings) spins on a fixed hollow shaft that is bolted tightly in place between the two foot plates. NOTE: Looney Bird has no *knee bend* movement.

2) Universal joint: There are two. Universal joints serve as the apex for two movements simultaneously. There is a large universal joint connecting the lower body shaft and upper body shaft that allows the *body tilt left* and *body tilt right* to be used in any combination. Similarly, there is a smaller universal joint in the neck region that allows the combined usage of both *head tilt* movements. NOTE: Looney Bird does not have *body tilt* cylinders; hence, the large universal joint does not pivot.

3) Ball joint: A ball joint pivot is actually a ball-in-socket joint, much like the hip joint of a human or a ball joint on a car's front suspension. The socket is free to spin about the ball even with small angles of deflection during the movement, i.e., things aren't always traveling exactly in a straight line, like the human hip joint that allows for the leg to go forward, backward, out, and in, and any combination therein. Ball joints are currently used ONLY for front and/or rear pivot points, and are not used for any apex pivots. The unique characteristic of a ball joint is that the ball (in which there is a hole for a bolt to pass through) should remain fixed. Since the socket is free to pivot at various angles around the ball, the ball should be locked in place by firmly tightening the bolt that attaches the ball (in the ball joint) to the other mechanisms of the character. There are five movements on each character that utilize the ball joint for their front and rear pivot points. They are the *head tilt left*, *head tilt right*, *body tilt left*, *body tilt right*, and *body turn right*. NOTE: Ball joints are also used for attaching the leg adjustment rods on the back side of each lower leg (except for Looney Bird - his knees don't bend).

4) Floating pin: This is the catch-all category, which simply means that any pivot point not listed above is a floating pin pivot. Floating pins can be only one of three different types that are easily recognizable. First is the steel dowel pin that is held in place by shaft collars (two or more). The shaft collars are tightened in place so that the "end play" of the pin (the distance the pin can actually slide from side-to-side) is kept to a minimum, yet the pin can still be turned (spun) by hand, or at least with VERY little effort using tools. Second is a steel dowel pin that doesn't require shaft collars. They have a spring-loaded ball or clip that keeps them from coming out instead of shaft collars. The third, and most popular, is the aircraft bolt/locknut combination. The aircraft bolt is used for the exact same purpose as a steel dowel pin - it must be free to spin within the pivot point. It may be a "bolt" but it should not be torqued tight - it is still a floating pin. Why use an aircraft bolt instead of a pin? Simple - the aircraft bolts are made to close tolerance (like a dowel), and they have a threaded end to allow you to tighten the locknut little-by-little to eliminate unnecessary end play without tightening it all the way - thus retaining the feature of a floating pin.

NOTE: Locknuts are used extensively, in their normal capacity, throughout the characters for tightly bolting parts together,

often with a lock nut as well. These locknuts (and bolts) should be tight. ONLY locknuts used at pivot points should be just loose enough for the bolt to spin.

CAUTION: When a locknut is used with an aircraft bolt to create a floating pin (as described above), never replace the locknut with a regular nut and lock washer - the results are NOT the same. The unique characteristic of the locknut is the nylon ring imbedded at the top of the threads that grips the threads of the bolt tight enough to prevent the nut from moving, even when it's left "loose" enough to allow the bolt to spin (function as a floating pin). On the contrary, a regular nut would have to be tightened all the way to prevent it from vibrating loose, but that's out of the question since the bolt would then not be free to spin!

SERVOS MOTORS:

Referred to simply as "servos," there are three used in each character head, each one controlling two movements that are opposite each other. One is used for *eyes left* and *eyes right*, one for *eyes up* and *eyes down*, and the third for *eyelids open* and *eyelids close*. Unlike cylinders and rotary actuators, the speed of the servos is not adjustable. The speed of a servo and the amount it spins in both directions are all controlled electronically by the bit-stripper. The cable that runs from the bit-stripper board, up through the character to the head, carries the power and control signals to the servos.

A servo has a center position where, for instance, the eyes are looking straight ahead (not left or right). The bit-stripper then sends a variable signal to rotate the servo one way or the other - in this case, causing the eyes to turn left or right of center. The other two servos work the same way.

The two most common causes of servo malfunction can both be prevented -

- 1) Cable pulled away from bit-stripper board: When removing or replacing the valve bank, carefully insure that the three cables from the bit-stripper are safely routed and won't be pinched or pulled.

- 2) Mask rubbing eyelids or eyes: As outlined in the MAINTENANCE section, when the mask is fit properly, the eyes should not be rubbing the mask, otherwise the mask will create a "drag" on the servos - something the servos are not especially designed to handle. As for the eyelids, they should either clear the mask or barely touch it during operation. Eyelid lube is used to ensure that slight contact won't cause sticking that might damage the servo. Simply keep in mind that servos are used for movements that produce very, very little resistance - they are not designed to do any real "work," like a cylinder.

MAINTENANCE

Routine maintenance on the show is more than important - it is absolutely necessary. The only difference between a well running show and a not-so-well running show is regular maintenance. As with any mechanical product, there will always be points of friction that require lubrication, and a small amount of normal wear that will affect certain adjustments.

For your convenience, the show is equipped with automatic oilers that handle the internal lubrication of all cylinders and air motors. There are only a few items on the show that require routine MANUAL lubrication: eyelids, eyes, turntable chains, and some character pivot points.

As for wear, with proper lubrication and adjustments, there should be a minimal amount. However, even a tiny amount of normal wear can affect the speed of character movements and turntables; hence, at the risk of sounding redundant, we cannot put enough emphasis on the importance of following the suggested schedules in this section.

DAILY, WEEKLY, and MONTHLY maintenance schedules appear on the following pages. It is suggested that you make plenty of photo copies of each schedule to use as checklists as the maintenance is performed. (Keep the originals in the manual for future copying.)

-- GO ON TO THE NEXT PAGE --

-- DAILY --

- * Before turning on air, check all oilers and fill as needed with 10W non-detergent hydraulic oil.
- * Follow the start up procedure, then visually inspect all characters for proper stance as described in THE CHARACTERS section. Any movement that is not in its proper starting position at this point requires your attention to find out why. Fixing any small problems NOW will prevent damage.
- * Look at the eyes and eyelids of each character for signs of sticking or lack of lubrication, and lubricate as needed.
- * Visually check the arms and shoulder areas of the characters for costume pinching or pulling.
- * Visually inspect the stages and props for any abnormal wear or damage.
- * Listen carefully for air leaks in the characters or under the stage. Don't allow air leaks to go without repair - aside from affecting movements, there is a small amount of oil mixed with the air that will soil parts surrounding the leak.
- * Brush fur and blow off characters that don't look their best. Doing this every couple days, needed or not, will prevent the fur from matting and keep the costumes clean.
- * Play a couple shows, watch for obvious mechanical problems, and make sure the audio system sounds normal.

-- WEEKLY --

- * Drain water from compressor air tank. Drain water from drier.
- * Drain water from air filter next to the pressure regulator.
- * Turn the air on and follow the normal start up routine, check pressure gauge for 80 p.s.i., and adjust pressure regulator if necessary. Never vary from 80 p.s.i.!
- * Using override toggle switches, cycle curtain cylinders and check for proper operation. Watch for binding cables and/or loose or missing weights.
- * Look under each side turntable and note the oil level in the reservoir closest to the back of the stage. Then, using the toggle switches, rotate both side turntables and check the oil levels in the other two reservoirs (which are now closest to the back of the stage). If any of the four reservoirs has less than 1/4 inch of visible oil at any time, refer to SIDE TURNTABLES section for instructions. Check for oil leaks on the fittings and around the cables where they enter each end of the cylinder.
- * Thoroughly inspect each character for proper stance. Carefully note the position of the arms, head, and body. Check for any excess free movement. When in doubt, remove the costume to inspect suspicious "sloppiness" or "looseness" in any part of the character.
- * Lubricate eyes and eyelids using CEI eye lube ONLY. Remove any old lube first, using a soft cotton cloth. Do Not use paper towels or napkins.
- * Use Show Adjustment Utilities to check the speed settings of the large turntable and the three character (small) turntables. Tables that are too slow will affect the choreography and need to be adjusted ASAP. Tables that are too fast will cause damage and breakdowns, and MUST be adjusted NOW.

Adjustment guidelines:

Large turntable - 13.5 to 14.5 seconds; ideally, 14 seconds

Small turntable - 6.1 to 6.5 seconds; ideally, the fastest setting within the range that does NOT allow the turntable to coast into the stop mechanism. While making adjustments, watch the feedback gear to see if the stop-bolt is hitting the stop-pin at the end of the rotation in either direction. If it does, slow that direction down (a very small amount at a time) until the stop-bolt comes to rest just before the stop-pin. This will achieve the quickest, SAFE speed.

-- MONTHLY --

- * Use the AUTO ASSIGN FOR ADJUST feature of ADJUST MOVEMENTS to check the speed of each pneumatic movement of each character. Select the first movement on the list (Mitzi is used as the sampling list for this feature), then select 1.0 SECOND TIMER to cycle that movement on all the characters at the same time. This feature not only saves time, but allows you adjust the speed of the movement AND synchronize that movement on all the characters simultaneously. The guidelines for setting all the movement speeds are outlined in THE CHARACTERS section. As with the turntables, a movement that is too slow will affect the choreography and should be adjusted ASAP, but a movement that is too fast will surely cause damage and MUST be adjusted immediately. If a particular movement is suddenly much too fast, correct the speed, but be suspicious of a possible flow control problem and pay close attention to that movement over the next few days. If a movement is suddenly much too slow, check immediately for any physical binding or interference with the movement. Also, listen carefully for any air leaks while the movement is cycling. If there is no apparent reason for the slowness, correct the speed, but treat the condition as a possible flow control problem and watch it carefully for a few days to see if it reoccurs.

- * As above, use the AUTO ASSIGN FOR ADJUST feature to check the servo movements (eyes and eyelids) of each character. Servo speeds are not adjustable, but it is important to check them for smooth, uninhibited movement. A "sticky" eyelid or eye can damage the servo motor and/or the linkage. Check the eyes and eyelids for proper lubrication as described in the WEEKLY schedule.

- * Each character of the show should be internally inspected once every three months. Therefore, if your show has three characters, choose one for each month; if your show has six characters, select two for each month. This process does not take very long! Following these instructions will greatly reduce unusual wear, prevent internal damage, and significantly add to the lifetime of the character.
 - 1) Once each month, remove the entire costume and mask from the scheduled character(s).

 - 2) Literally start at the top of the head. Carefully inspect every visible part of the character all the way down to the feet. (If you disconnected the air to remove the costume, reconnect it now - it will make it easier to notice abnormal looseness in the character.)

-- MONTHLY (cont.) --

3) Check for any loose screws, bolts, nuts, or shaft collars. REMEMBER: There are many bolt/locknut combinations acting as pivoting bolts throughout the character, and over-tightening them will hamper movement and possibly cause damage. When in doubt, refer to THE CHARACTER section for help in determining the difference! All hardware that is supposed to be tight should be checked (with tools) for tightness. All pivoting bolts should be just loose enough to spin freely, but should not have excess "end play" (defined in THE CHARACTER section).

4) After inspecting all the components of the character, expose the valve bank and manually actuate each movement at least a dozen times. The movement should be smooth and steady. There shouldn't be ANY binding or slamming.

5) If any part needs to be replaced, now is the best opportunity to replace it. If you don't have the required part on hand, order it right away. NOTE: If necessary, a movement can be temporarily stopped (while waiting for a new part) by closing the flow controls for that movement. You can avoid repair delays by keeping the spare parts kit stocked.

6) Make sure all clear plastic moldings are properly in place, then replace the mask and costume. With the character fully dressed, check the movement speeds one more time for correct adjustment.

*** CAUTION: Before performing the next few steps, disconnect the air line that feeds the large turntable air motor. Being under the center stage is safer with the air to the motor disconnected.

The next few steps require being under the center stage (the large turntable).

* Inspect the main harness that feeds the large turntable and the air lines/wire harnesses that are suspended below each cradle. Look for wear or cuts in the air hoses or protective cable sleeving. Worn or cut air hose should be replaced. Worn wire harnesses, if caught early enough, can be protected with new sleeving.

* Check the chains on the three character cradles for proper tension. (The diagram at the end of this section briefly describes the process of checking and/or adjusting chain tension.)

-- MONTHLY (cont.) --

- * Use a blow gun to clear away any dust on the four sets of infrared boards.
- * Check (for tightness) all bolts associated with the 6-inch wheels that support the center stage large turntable and the side stage turntables.
- * Inspect large air motor drive tire for wear. Remove any rubber tire particles with a vacuum. Replace the tire if necessary.
- * Check (for tightness) all 1/4-20 flat-head bolts that secure the diamond plate to the outside of the large turntable. At the same time, check the 1/4-20 flat-head bolts that secure the running boards (the curved plastic boards that ride on the 6-inch wheels) to the bottom side of the large turntable. If looseness is a problem, you can remove the bolt, lightly coat the threads with NON-permanent Loc-Tite thread sealer, and re-tighten the bolt in place.

- *** When you are finished under the stage, remember to reconnect the air line.

- * Perform routine maintenance on your air compressor as prescribed by its manufacturer.

- * Do general housekeeping, e.g., dust the props, vacuum the set, organize your spare parts area (re-order anything that you have used).

- * Finally, use a TOP QUALITY video tape head cleaner on your tape deck(s).

CHAIN ADJUSTMENT: When a chain is stretched around two sprockets, like a v-belt is stretched around two pulleys, the tension is determined by "deflection." The deflection can be checked with MODERATE thumb pressure applied midway between the sprockets. The simple drawing below represents two sprockets and the chain between them. The deflection of either chain on the character cradle should be no less than 1/8 inch and no more than 3/8 inch. The air moter is attached to the cradle by a bracket with four bolts through slotted holes. These slots allow for tension adjustment of the drive chain. The other chain, the feedback gear chain, can only be adjusted by loosening the feedback shaft flange bearing bolts, removing excess chain slack, and retightening the bolts.

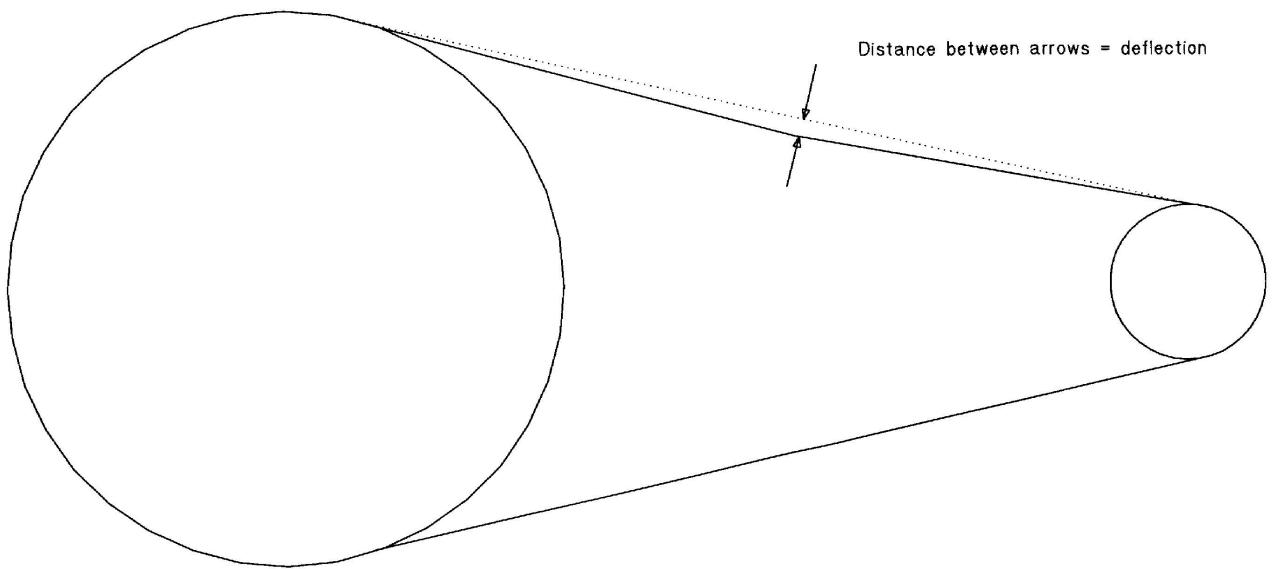

Title:	Chain adjustment tolerances	Tolerance (unless indicated):	Creative Engineering, Inc. 47 West Jefferson Street Orlando, Florida 32801
Date:	06/18/95		

TERMS AND DEFINITIONS

AIR FILTER: Located between the main air source line and the pressure regulator, the filter does two things: it has a filter cartridge that prevents foreign air-borne particles from entering the system, and it has a large clear bowl that allows water vapor to collect in the form of water to be drained by using the drain cock at the bottom of the bowl.

AIR MOTOR: Actual motor that is powered by pressurized air instead of electricity or fuel. Air motors are used to move the large turntable and the three small (character) turntables. Air motors can spin in either direction by controlling the direction of air flow.

BIG IMPORTANT BOARD: Large printed circuit board mounted in the control rack that performs many duties - switches audio inputs between the two video decks, controls all center stage turntables (reads positions and operates air motors), controls strobe light, sends video to TV's, and patches data through to bit-strippers for lights, props, and stage-right characters. (This board was once referred to as the Turntable Board.)

BIT-STRIPPERS: Individual, large printed circuit boards that interpret show-play data from the computer. They are ultimately in-charge of shifting valves, controlling servos, and controlling spot lights and neon lights.

BLOW-BY: The condition of air in one end of a cylinder leaking past the main piston seal into the other end of the cylinder, lessening the normal force of the cylinder. A cylinder with severe blow-by may hesitate greatly or even not move at all when the valve is shifted.

BOARDS: Plug-in boards inside the computer. There are currently six boards in the computer. Their slot numbers and names are:
1) Decoder, 2) Show-Play, 3) Director of Communications (DOC),
4) RS-232, 5) Disk Interface, 7) Lightpen (and modem).

CABLE CYLINDER: Long stroke cylinder with a cable attached to each end of the piston. The cables exit the cylinder at each end, travel around pulleys, and attach to a common bracket. They are used for raising curtains and turning the side turntables.

CLEVIS: Slotted block of metal threaded onto the piston shaft of a cylinder used as a front mount mechanism. The slot forms two tangs. The tangs have holes in which the floating pin spins. Clevises are currently used for the front mount of each of the following: *head up, shoulder raises, wrists, and knee bend.*

CLIPPARD CYLINDERS: Single-acting cylinders currently used in the rabbit ears.

COSTUMES: Clothing, latex parts, and furring worn by the characters.

CYLINDER: Pneumatic device that is cylindrically-shaped with a piston shaft (rod) extending from one end that travels straight out (extended) and straight back (retracted). The cylinder is the most common device used to actuate movement. Most cylinders are double-acting, meaning they have two air lines and can be forced (by air pressure) to move in either direction. The cylinders used in the rabbit ears on the large TV are single-acting, meaning they have one air line to extend the cylinder and an internal spring to retract the rod.

CUSTOMER PANEL: Show Selector system interface stand that sits in front of the stage and allows customers to choose the next song.

END PLAY: The distance a floating pin can travel linearly in a pivot point before the bolt-head, locknut, or shaft collar stops the pin from going any farther. End play should be kept to a minimum - 1/32 inch is more than enough.

FEEDBACK GEAR: Large sprocket used on each character turn table and the large turntable. Feedback gears rotate when the turntables rotate. They have a series of drilled-hole combinations that permit light to travel from the infrared light emitters to the collectors. The specific combinations report the exact position of the turntable to the Big Important Board.

FLOW CONTROL: Device used to control (or meter) the rate at which exhaust air is allowed to flow back to the valve bank from the cylinder, rotary actuator, or air motor.

INFRARED BOARDS: Printed circuit boards (in pairs) that straddle a feedback gear and report the position of the large turntable and character turntables to the Big Important Board.

LOCKNUT: A specially designed nut with a nylon ring molded into the top end of the nut. The purpose of the nylon is to very firmly grip the threads of the bolt onto which the nut is threaded. Locknuts are used in two capacities. First, they are used all over the character in place of regular nuts (usually with lock washers) to firmly tighten two parts together. Second, they are used in many pivot points along with an aircraft bolt to become a floating pin. In this application only, the nut is left "slightly" loose to allow the bolt (pivot pin) to spin, and the nylon ring keeps the nut in its original location instead of vibrating loose and falling off (as would a regular nut).

MAIN HARNESS: The two air hoses and several electrical cables, all bundled together in protective sleeving, that feed air and power to the large turntable. The main harness is literally pulled around by the harness hanger under the turntable as the table rotates. Also, each side turntable has a main harness, each containing one air hose and electrical cables.

MANAGER PANEL: Show Selector system interface panel (not accessible to customers), used by store personnel to start birthday songs or special promotional skits.

MUFFLERS: Foam-filled aluminum chambers used to muffle the air from the exhaust ports of the valve banks. Character mufflers are small and cylindrically-shaped. Mufflers for the props and character turntables are made of 2 x 2 aluminum box, roughly seven inches long.

OILERS: Located at the main air distribution manifold (and one located near large turntable air motor), they are automatic lubrication devices that inject a very small amount of oil into the air that passes through. The oil subsequently lubricates the cylinder, rotaries, and air motors. On the small oilers, the bowl unscrews for refilling. On the larger models, there is a black plug next to the adjustment knob that unscrews for filling. With either type, bleed down all air pressure before and after the oiler before servicing.

PAR 46 CANS: Colored lights used for special effects that require a 200 watt spot bulb.

PIVOT POINT: The apex, front mount, and rear mount of any cylinder-based movement. (See CHARACTER section for details.)

PLASTIC MOLDINGS: Vacuum formed plastic parts (usually clear) used to add form to the characters and prevent the costumes from rubbing the mechanisms. The standard character uses moldings for chest, back, upper arms, lower arms, upper legs, lower legs, shoulders, and skull.

PLUMBING HARNESS: Group of air hoses beginning at the quick release and running up through the character to the cylinders and rotary actuators. There are four harnesses for each character.

POWER SUPPLY: Converts 110 AC volts to one or more specific DC voltages. The main power supply is located on the bottom shelf of the audio/control rack, providing 5, 8.5, and 24 volts for the bit-stripper boards and valves. A smaller power supply sits behind the Big Important Board, providing +5, -5, +12, and -12 volts for the Big Important Board itself.

PROPS: Animated, cylinder-controlled devices aside from the characters themselves. There are three props valve banks, one mounted on each side turntable (near the cable cylinder) to control side turntables, rabbit ears, coconut, and window; and one mounted near the large air motor to control curtains and imitation speakers. For details, see PROPS/LIGHTS section.

PUSH-LOC HOSE: Air hose of 1/4 or 3/8 I.D. (internal diameter) that can be pushed firmly onto special barbed fittings and require no clamps.

QUICK RELEASE: Two-piece devices with ten air hose fittings on each half that can be unlocked and separated to permit the complete removal of a valve bank away from a character. (There are a few smaller, two hose [single movement] quick releases used for props.)

REGULATOR: Maintains a constant air pressure for the entire show. The [pressure] regulator is located between the air filter and the main air distribution manifold. The regulator should be set to 80 p.s.i. at all times.

RODEND: A rodend is any pivoting device that screws on to or into the end of a cylinder shaft (rod) or threaded rod to create a pivot point. Some different types are solid block, clevis, and ball joint. (The ball joint type, or "spherical ball rodend," is often simply referred to as a "rodend" throughout the industry.)

SERVO: Small, internally geared motors (like those in model airplanes), used to move the eyes and eyelids. The speed and stroke of a servo are not adjustable - they are completely controlled by the bit-stripper board.

SIDE LOAD: A condition where the shaft (rod) of a cylinder is stressed sideways during the movement. Side load will lead to immediate seal wear and eventually metal-to-metal internal damage. Side load is the result of misaligned movement parts.

SPOTLIGHTS: High wattage, white lights used to light up a single character for accentuation (like solo singing). These lights have fixed irises and require a 500 watt EHD bulb.

STANCE (Proper): The position of the character with all movements in their proper starting positions, i.e., ALL movements OFF.

STARTING POSITION: Position of a character when all movements are turned OFF.

SYNC: Short for "synchronization," it means that a turntable and its chain-driven feedback gear are rotating properly with relationship to each other. (Side turntables are cable cylinder actuated and don't have feedback gears.) Turntables that go beyond their normal extremes (clockwise and counterclockwise) will no longer be in sync.

TRANSFORMER: Used to power the neon lights, they are mounted on back side of the rear walls of the show. These transformers produce output voltages around 10,000 volts and should be treated with the utmost respect. DO NOT tamper with them unless you are experienced with this type of equipment.

TRIAC: Solid-state device used to control high-voltage AC lighting. An isolated, low-voltage circuit on one side closes the high-voltage gate on the other side. Triacs are located in the electrical panel next to the breaker box.

VALVE: Electrical/mechanical device that utilizes a electric solenoid to shift a mechanical valve to and fro to control the flow of pressurized air. A typical valve has an inlet port, exhaust port, and two line ports that go (by hose) to the cylinder or rotary actuator. One line port is normally pressurized while the other is normally open to exhaust freely. When the solenoid is energized and the valve shifted, the roles of the ports reverse. This type valve is the most common.

VALVE (air motor): These valves work differently than a valve for a cylinder. Air motors require a constant flow of air to operate; consequently, when the motor is off, the air motor valve's OFF position has both line ports closed - no air to the motor, no air from the motor - the motor is still. The valve can then be shifted one of TWO directions away from the middle OFF position. One shift delivers pressurized air to one line port and exhausts the other, spinning the motor in one direction. The other shift simply does the opposite with the line ports, spinning the motor in the other direction.

VALVE BANK: Series of valves bolted together in-line to allow for one main air inlet and one exhaust outlet, as opposed to each and every individual valve having its own set. In the case of a character, the double banks mounted to a base board and interconnected by hoses and wires are collectively called the Valve Bank.

Appendix A

The box below is to be attached to the front of the small audio amplifier in the audio rack.

THIS UNIT IS USED SOLELY FOR MATCHING THE AUDIO LEVEL OF THE THANK YOU DECK TO THE SHOW DECK. IF THE THANK YOU'S ARE NOTICEABLY LOUDER THAN THE SHOW SONGS, USE THIS DEVICE TO LOWER THE LOUDNESS OF THE THANK YOU'S TO MATCH THE SONGS. IF THE THANK YOU'S ARE TOO LOW, USE THIS AMPLIFIER TO INCREASE THE LOUDNESS OF THE THANK YOU'S TO MATCH THE SHOW SONGS.

THIS UNIT IS USED SOLELY FOR MATCHING THE AUDIO LEVEL OF THE THANK YOU DECK TO THE SHOW DECK. IF THE THANK YOU'S ARE NOTICEABLY LOUDER THAN THE SHOW SONGS, USE THIS DEVICE TO LOWER THE LOUDNESS OF THE THANK YOU'S TO MATCH THE SONGS. IF THE THANK YOU'S ARE TOO LOW, USE THIS AMPLIFIER TO INCREASE THE LOUDNESS OF THE THANK YOU'S TO MATCH THE SHOW SONGS.

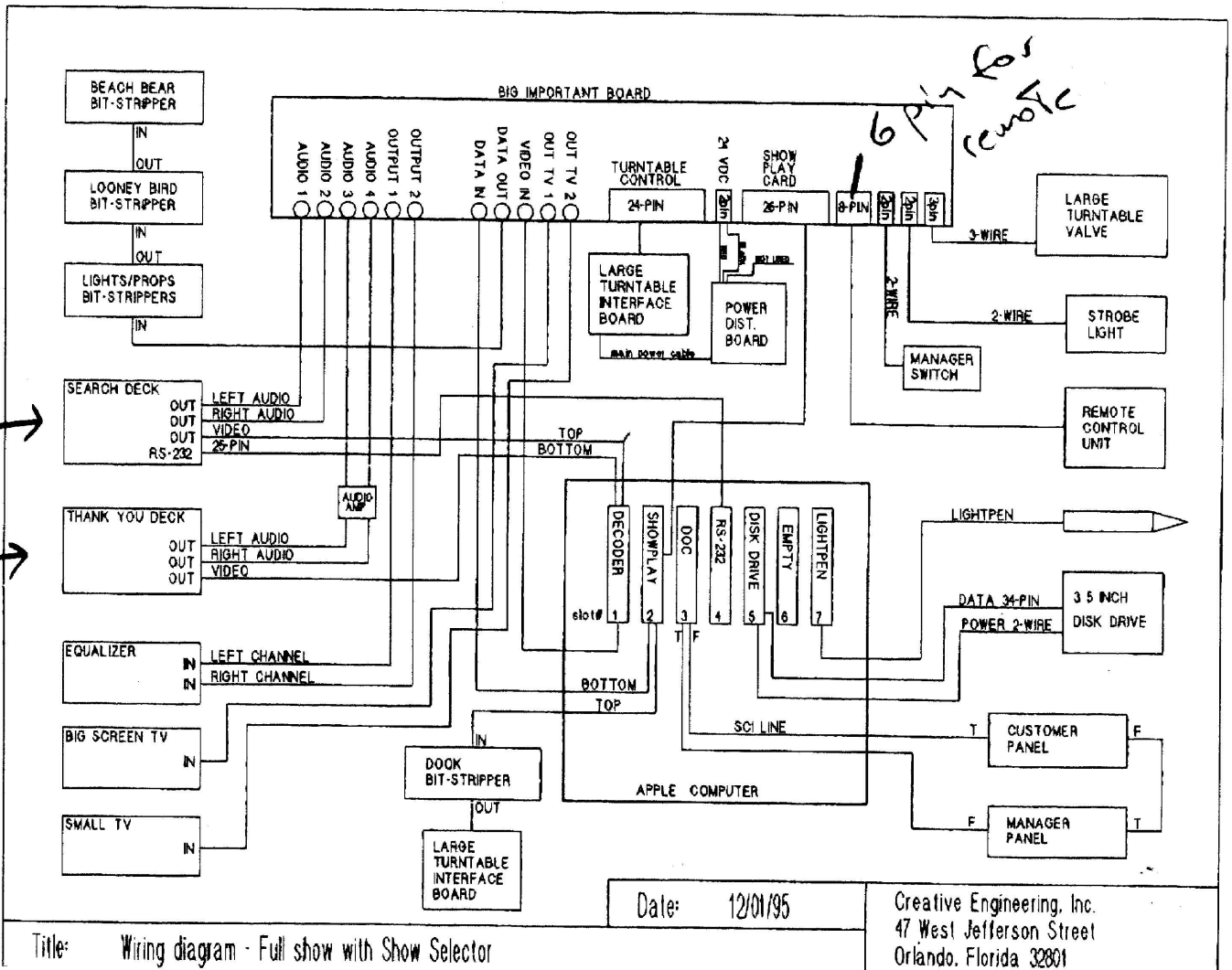

Title: Wiring diagram - Full show with Show Selector

Date: 12/01/95

Creative Engineering, Inc.
47 West Jefferson Street
Orlando, Florida 32801

THE NEW ROCK-AFIRE EXPLOSION USER'S MANUAL AND REFERENCE GUIDE

(Variation 2 - Odyssey Fun World, Tinley Park)

Date of Origin: 1995
Archived: 4-12-19
Submission by mafia
Version 1.0

The documents contained herein are for educational use only.
Please do not replicate, redistribute, or make any unauthorized
printings. All intellectual property including characters,
artwork, photography, and slogans are trademark and/or
copyright their respective owners.

