

SHOWBIZ PIZZA TIME, INC.





ATTRACTION DEVELOPMENT PROGRAM

PROJECT OBJECTIVES

1. Provide a plan for a staged evolution of the Concept.
2. Determine individual tactics to improve the customer experience that are reasonably implemented in the average location.
3. Test new attractions.
4. Develop a tighter theme throughout the store.
5. Improve overall ambiance.
6. Provide a method for proper testing of entertainment ideas.
7. Increase sales by capital investments that show an ~~expected ROI~~ of at least 12%.
8. Find the best ways to integrate attractions so that the whole effect is greater than the sum of its parts.
9. Implement designs in ~~at least four~~ Prototype locations.

PROJECT STRATEGIES

1. Improve Adult experience.
2. Maintain or Improve child experience.
3. Stengthen "restaurant" perception in order to expand market potential.
4. Plan for reasonable evolution.
5. Be aware of available entertainment options and potential applications.
6. Give customers a reason to visit more often.
7. Conclude consumer research that focuses on the entertainment part of the business.

FORMATION & RESPONSIBILITIES OF 3 TEAMS

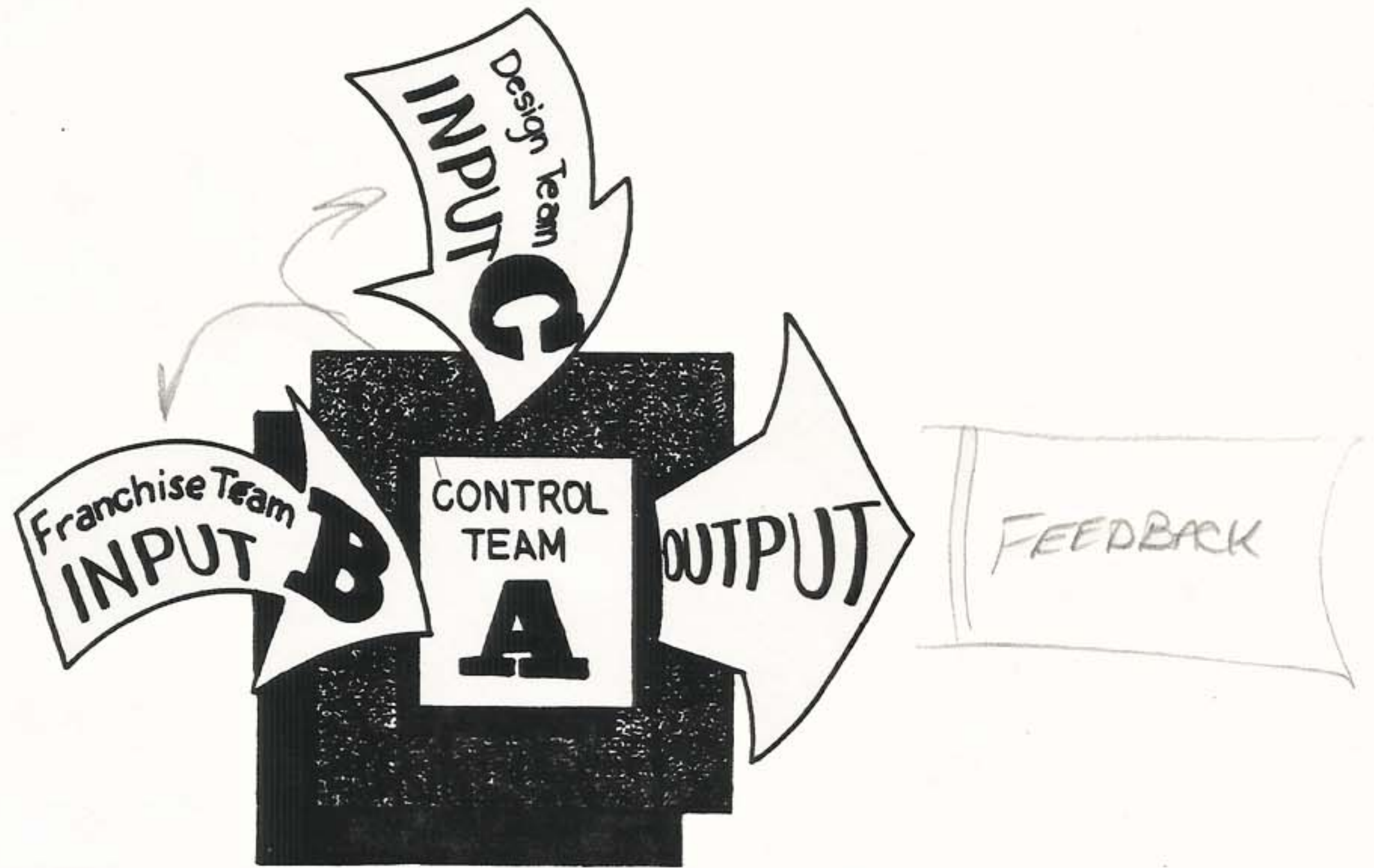

CONTROL TEAM Stan Black, Paul Linden, Jul Kamen

Develop the objectives and strategies of the project. Analyze, test and assign priorities to the ideas. Provide technical assistance for implementing the approved tactics. Develop and implement cost controls.

- . Control budget
- . Establish objectives
- . Approve new attractions
- . Determine scheduling



FRANCHISE TEAM Mike Flynn, Tim Kolb, Tom Pogemiller, Bryon Schlosser

Provide feedback on proposed attractions. Review and approve design concepts for funding. Represent franchisee interests.

- .Condition of franchisee facilities and equipment.
- .Growth trends
- .Architectural problems
- .Special local problems
- .Geographical competition



DESIGN TEAM Gene Patrick, Paul Price

Given free rein to their imagination and entertainment flair to develop bold and innovative cost effective strategic ideas. Guided by the Control Team and following an established plan to reach the goals established by the Control Team and Franchise Team. Take finalized tactics and implement into a final plan integrating with architectural constraints and interior elements that contribute to the success of the operation.

ANALYSIS OF NEW ATTRACTION POTENTIAL

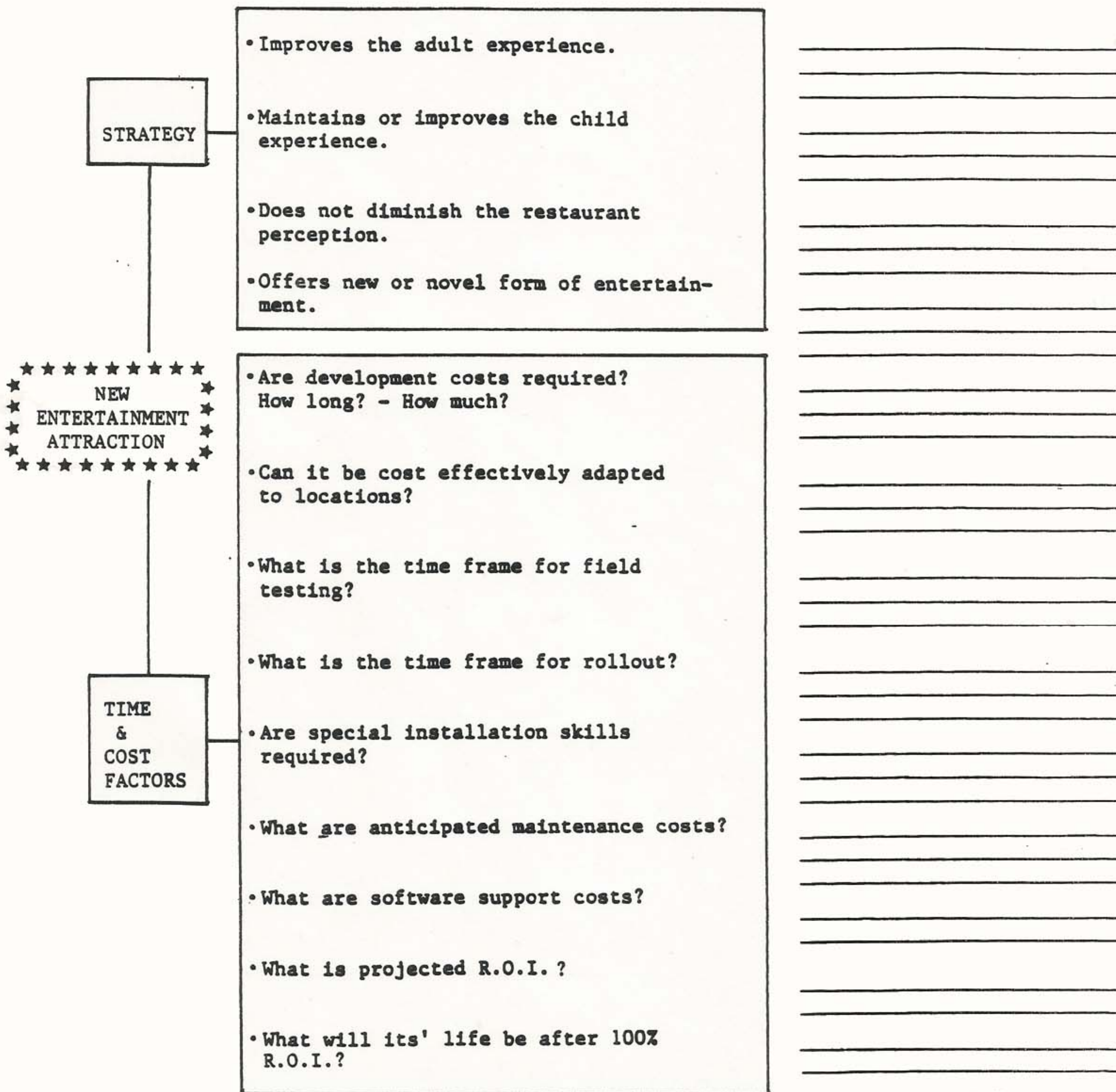

ATTRACTION IDEA DEFINITIONS

1. *50K* COMPUTERVISION- Large screen (4' x 12' or 5' x 15') utilizing front projection by either 12 slide projectors or a video projector. Capable of 10 frame/second animation. Can combine photographic backgrounds with cartoon images. A scrolling unit is imbedded in the screen which can be used to display personal messages. Also includes 12 channel chase light strips behind the screen.

2. CYBERVISION- Allows anything on video to interact in synchronization with the show. Video Hi-Fi unit simplifies operations and equipment by combining show, video, birthdays, background music, and monitor display all onto one programmed tape.

3. *20K* VIDEO WALL- Consists of a "wall" of 16 monitors stacked 4 x 4. Capable of displaying individual images, or one large image, panoramas, etc. Can interact with the show.

4. *10-15K* SPECIAL EVENTS VIDEO- A pre-set, pre-focused video camera that films the birthday person acting out a series of specific events, assisted by the birthday hostess. Those filmed segments are then automatically spliced into pre-recorded footage. The end result is a video tape starring the birthday person in a "professional" movie production. This tape would be available for purchase, or recorded over for the next event.

5. "SURPRIZES"- (Dispersed Animation) A myriad of subtle animated effects which randomly occur through out the store. Example: Plants which seem to "grow", brick pillars which wink, a bird which "flies" across the room.

6. "PIXIELAND BAND"- A smaller but more elaborate stage onto which lively animated characters magically appear. The characters are actually projected "ghost" images.

7. LIVE ENTERTAINMENT/ ANIMATED SHOW- The showtape script is written with "windows" for a professional live actor, disguised as an ordinary cast member, to respond, interact, and perform with the animated characters. This also includes walkarounds interacting with the show.

8. FULL BODIED CYBERS- (CEC only) The stage is modified and the floor is dropped to almost ground level to "reveal" whole characters.

7050K/3 stores

9. LICENSED CHARACTERS- Replace one or more of our existing characters with a well-known popular character chosen from T.V., movie, toy or cartoon sources.

10. REPLACING CHARACTERS- Creating Brand new characters for either system, or swapping characters for guest appearances such as Chuck E. Cheese appearing on the ShowBiz stage.

2.5K

11. ELECTRONIC BACKDROP- A new show cyc. (backdrop) containing a matrix of lights behind it which, when programmed, creates a flashy effect.

12. LIGHT PARADE- Wire form miniature sculptures with attached miniature chase lights that would be moved across the theatre near the ceiling as a finale to shows.

13. LIGHT FOUNTAIN- Fiberoptic or wire formed fountain with attached lights with 24+ channel chase to give the illusion of a water fountain.

14. LASER: BEAM EFFECTS- High-powered lighting effects resulting in visible "bars" of light passing overhead or on stage.

15. LASER- SCANNING EFFECTS- The use of lasers to create a graphic visual effect on a screen.

16. "BUBBLES"- Narrow divider walls or windows containing water which, when programmed, emit bubble effects in time with the music.

17. INTERACTIVE ANIMATION- The use of animated characters interacting with the customers in a more controlled effective way.

Lowest
Priority

18. CABARET ENHANCEMENTS- A new presentation of the existing cabaret characters in CEC and the introduction of a new character in ShowBiz.

19. MAGIC TRICKS- The use of special effects with the show to create magic illusions.

20. DRAPES FOR CEC- Activated curtains for the CEC stage (or part of).

21. BACKLIT TRANSPARENCIES- The use of backlit scenes recessed into the showroom walls to create environmental effects (such as sunrise) done by a gradual change in lighting.

22. WINDOWS WITH MOTORIZED BLINDS- Adding windows to the showroom containing vertical blinds which would be programmed to close automatically at the start of a show.
-
23. OSCILLATORS- A bank of 4 colored spotlights installed in the showroom which randomly sweep the audience immediately prior to showtime.
-
24. LIGHTING EFFECTS- These include Tivoli Lights, Chase Lights and Neon which could be used in conjunction with the show and/ or as a part of the interior design to highlight specific areas.
-
25. SOUND QUALITY- Improved sound in the showroom, especially in CEC.
-
- 4K 26. TRIKE CHARACTER- An animated character riding a tricycle operated by remote control which can act as a game room attendant, showroom heckler, outside barker, etc.
-
27. WALK-THRU- Various entertaining environmental experiences erected using modular walls or units. Some examples are :
- Haunted House
 - Lazer Maze
 - Fun House
 - Magic Maze
 - Santa's Workshop
-
28. FREE KID-POWERED RIDES- Free rides requiring physical activity rather than electricity for operation.
-
29. PARENT/ CHILD INTERACTIVE AREA- Activity area for small children specifically designed to include adult participation.
-
30. CUSTOM GAMES/ RIDES- Games designed for us especially in the areas of:
- New Kiddie Rides
 - Skill Games
 - Educational Games
-
- 1.2K 31. ROBOT SIGN- An immobile robot character with movable mouth that would repeat a message whenever anyone passes by it.
-

~~32.~~ CONVENTIONAL THEATRICAL LIGHTING- Replacing current CFC lighting fixtures with theatrical spots. Use of theatrical dimmers with all stage fixtures.

~~33.~~ REVOLVING CHARACTER- Use of a mechanical turntable or other means to reveal a character or change characters in a single area on stage.

~~34.~~ HOLOGRAMS- Use of holograms to supplement decor ideas and possible use as promotional give-aways.

~~35.~~ Exit experience

Corporate

El Cajon - CFC

? Peoria - SPP

Bryon

recomendation -

^{up to H}

Full installation in Corporate Stores

Individual pieces in Franchise Stores

Detailed

Design 2 corporate immediately

Individual pieces to Franchisees

Design "Store of the Future"

Committee Responsibilities

A. Show Room

B. SPECIAL EVENTS

C. Free standing Attractions

D. Infrastructure (Enhancements)

ANALYSIS OF NEW ATTRACTION POTENTIAL

Computer Vision

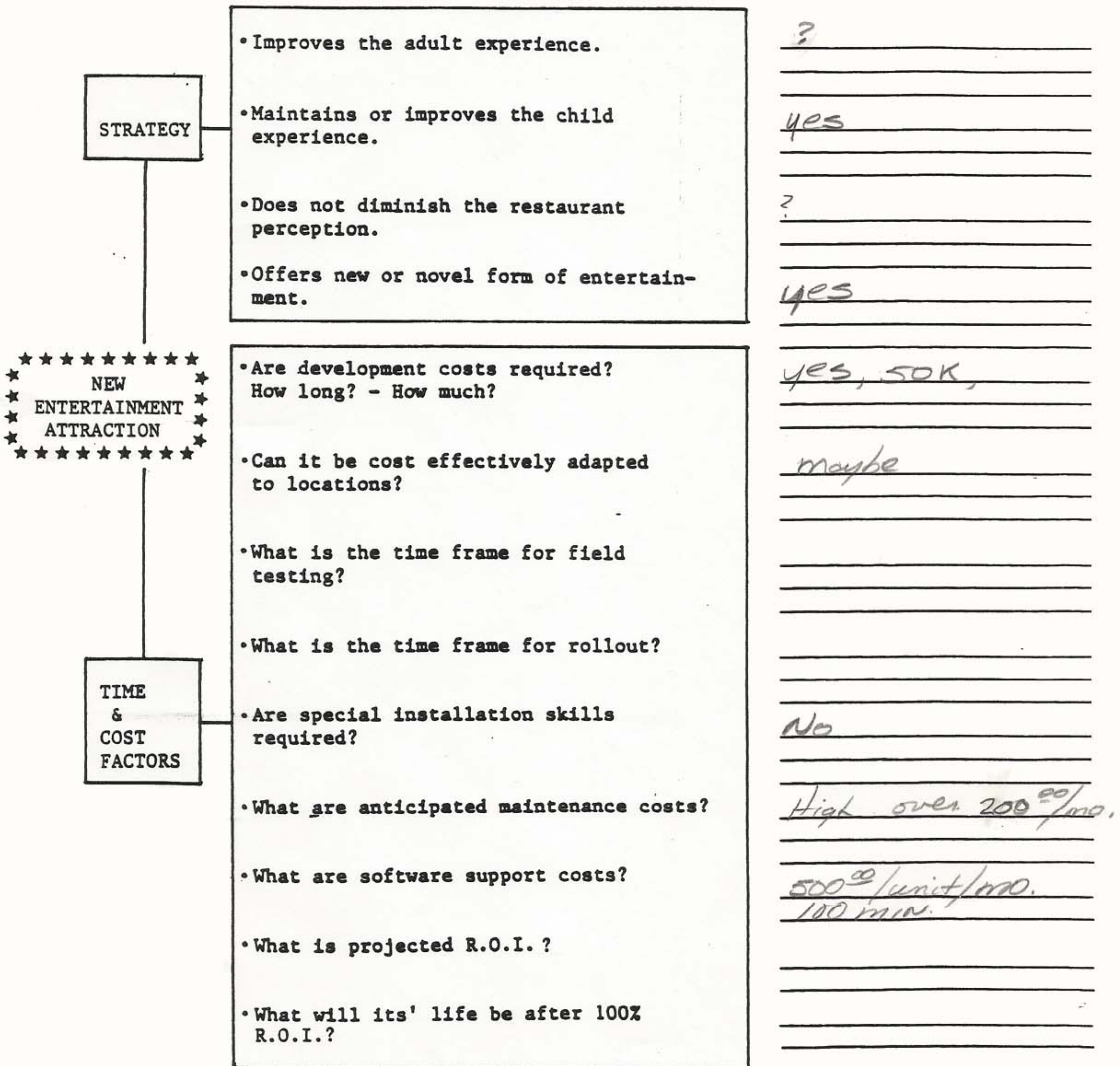

ANALYSIS OF NEW ATTRACTION POTENTIAL

CyberVision

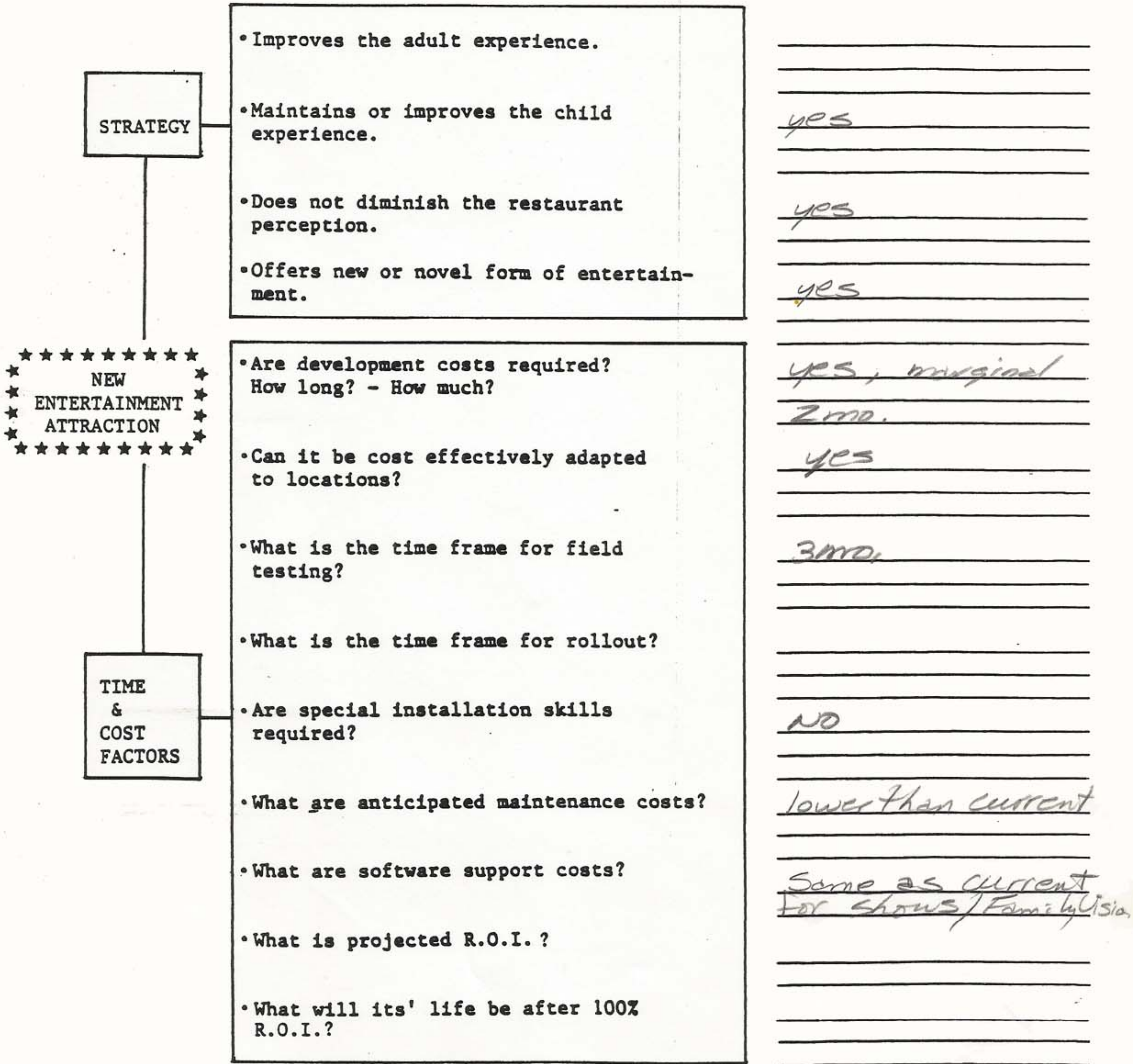

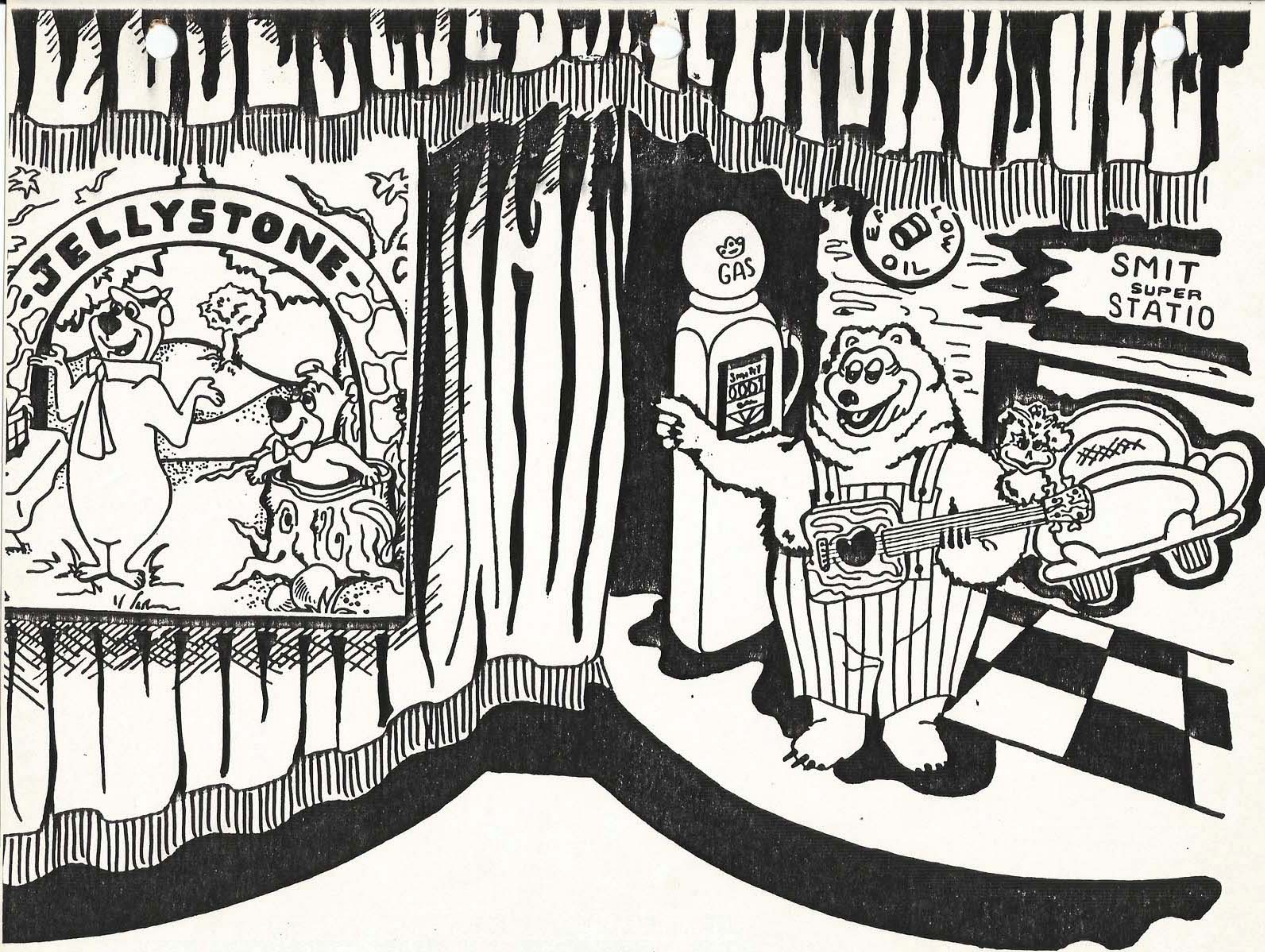

JELLYSTONE

GAS
SMIT SUPER STATIO

OIL MOTOR

SMIT
SUPER
STATIO



CYBER VISION PLAN

OBJECTIVES

1. Evaluate the feasibility of VHS HiFi Hardware utilization for animation control.
2. Determine whether the data integrity and tape life are sufficient for 2 month minimum.
3. Install minimum of 1 system in a test location.
4. Investigate the feasibility of cost effective software support.

STRATEGY

1. Use minimum system features for 1st test. (Show, Bkg. music, Countdown, Family Vision).
2. Design hardware for as much expansion as possible.
3. Add software enhancements as feasible.
4. Evaluate data integrity.
5. Evaluate operational changes necessary for B'day procedure.

TACTICS

1. Resolve 24 V. switching problem with B'day bit.
2. Master and send tapes to Ray Davis for Data files.
3. Edit data files for new bits.
4. Improve countdown
5. Obtain 3/4" duping master of Family Vision material.
6. Draw system wiring diagram.
7. Determine necessary pre-installation wiring.
8. Master tape
9. Pre installation training
 - Technical
 - Operational
10. Build Mgr. Control panel
11. Install system
12. Analyze feedback & make necessary modifications.

ITEM	Assigned	Oct1/5	Oct6/12	Oct13/19	Oct20/26	Oct27/Nov2	Nov3/9	Nov10/16	Dec8/14	Dec15/21	Dec22/28	Dec29/Jan
Tapes for Data Files	Paul	X	X									
Create Data Files	Ray Davis			X	X							
Edit Data Files	Joe/Paul				X				X	X		
Resolve 24v. Problem	Tommy	X	X									
FV 3/4" Duping Master	Steve			X		X						
Put Countdown on Tape	Dave			X								
System Wiring Diagram	Paul				X	X						
Pre-installation Wiring	Charlie							X	X			
Pre-installation Training	Paul/Bill										X	X
Build Mgr. Control Panel	Tommy			X	X							
Build Stone System	Tommy			X	X	X						
Master Show Tape	Joe/Paul									X		
Dupe Show Tape	Joe/Paul									X		
Install System	Tech Ser											X

ISSUES:

1. Interactive Animation must be disabled.
2. The 24 volt switching problem must be satisfactorily resolved.
3. No special showtapes are to be produced.
4. The system mandates a change in Birthday operational procedures.

ANALYSIS OF NEW ATTRACTION POTENTIAL

VIDEO WALL

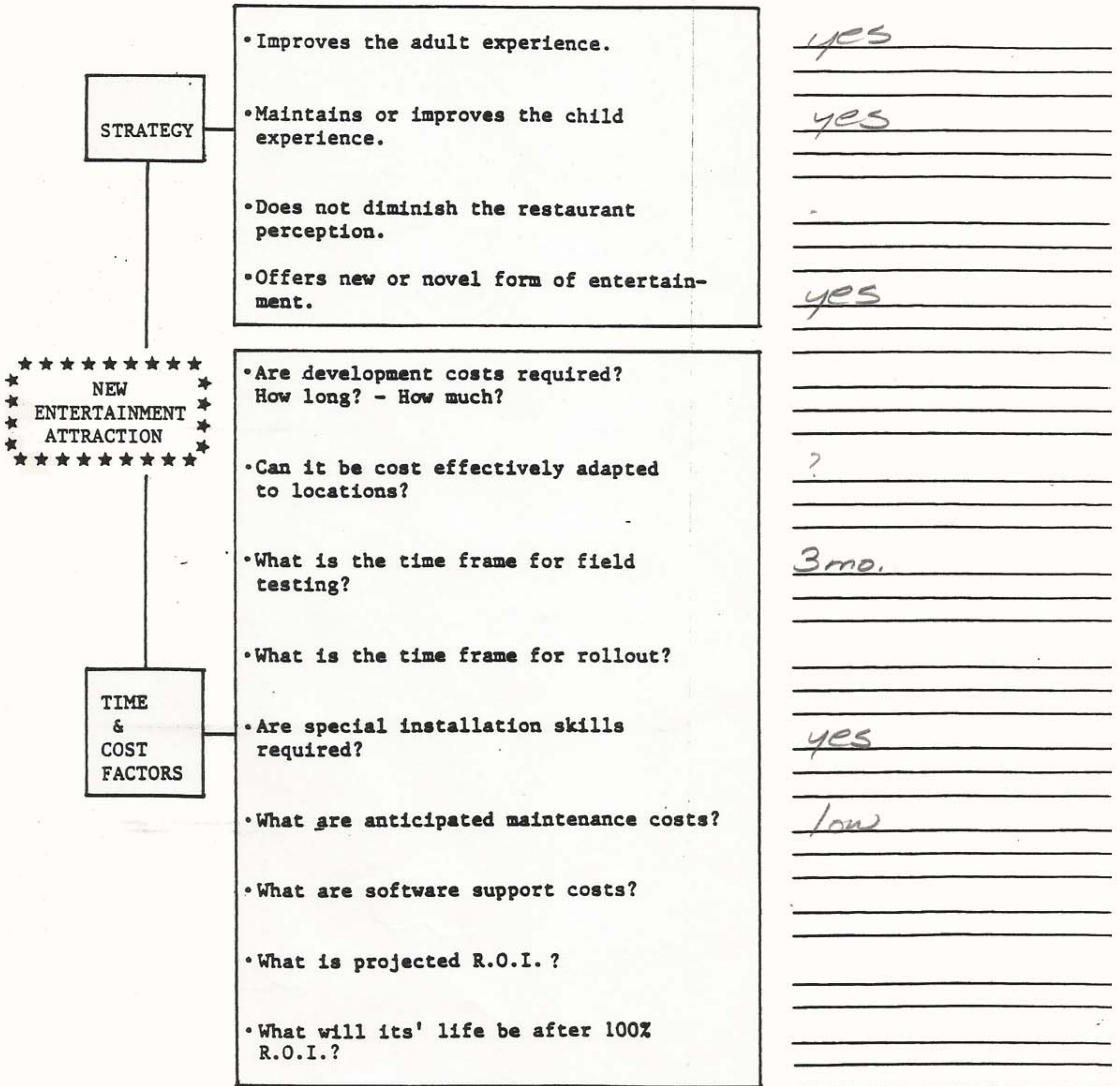



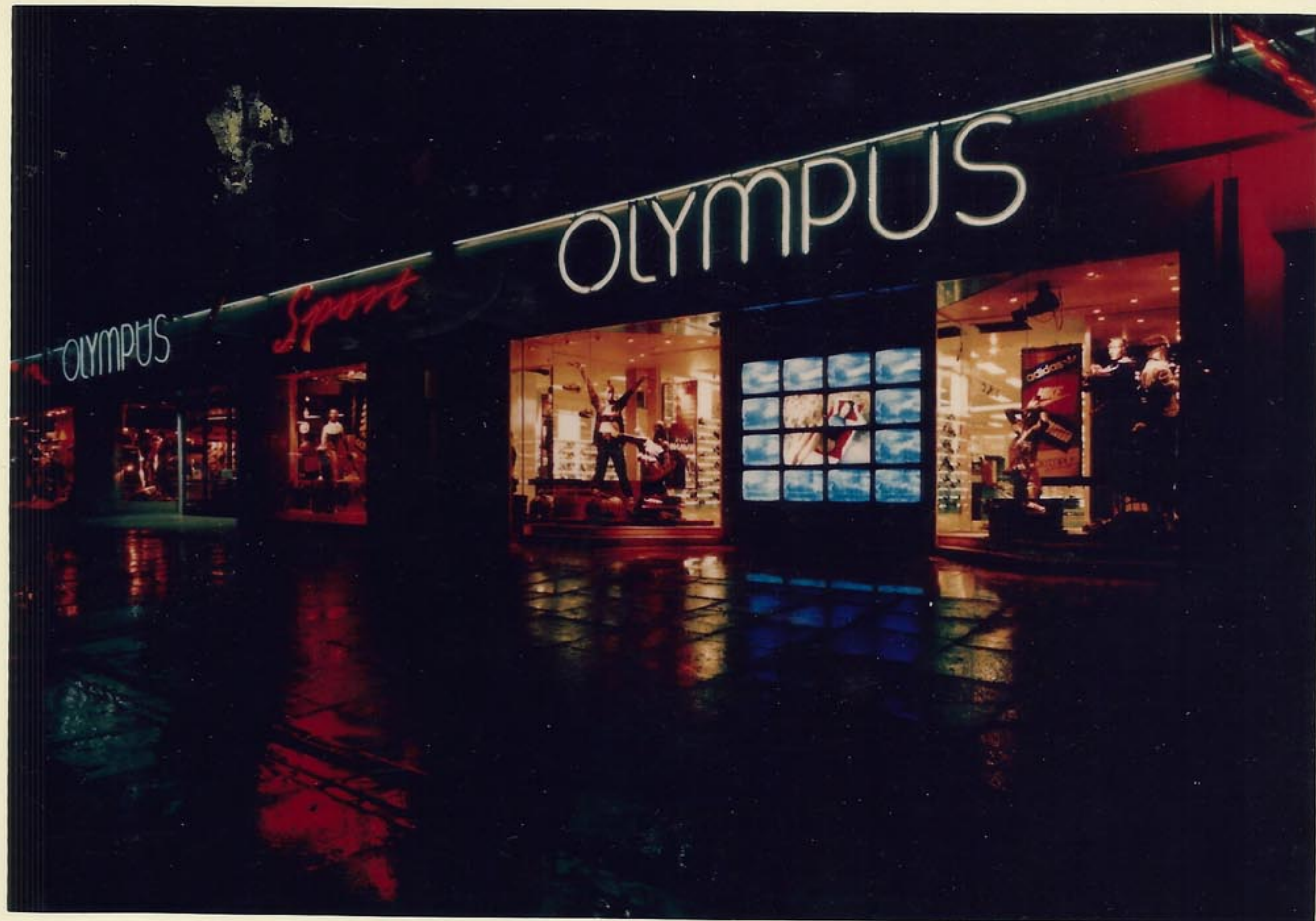

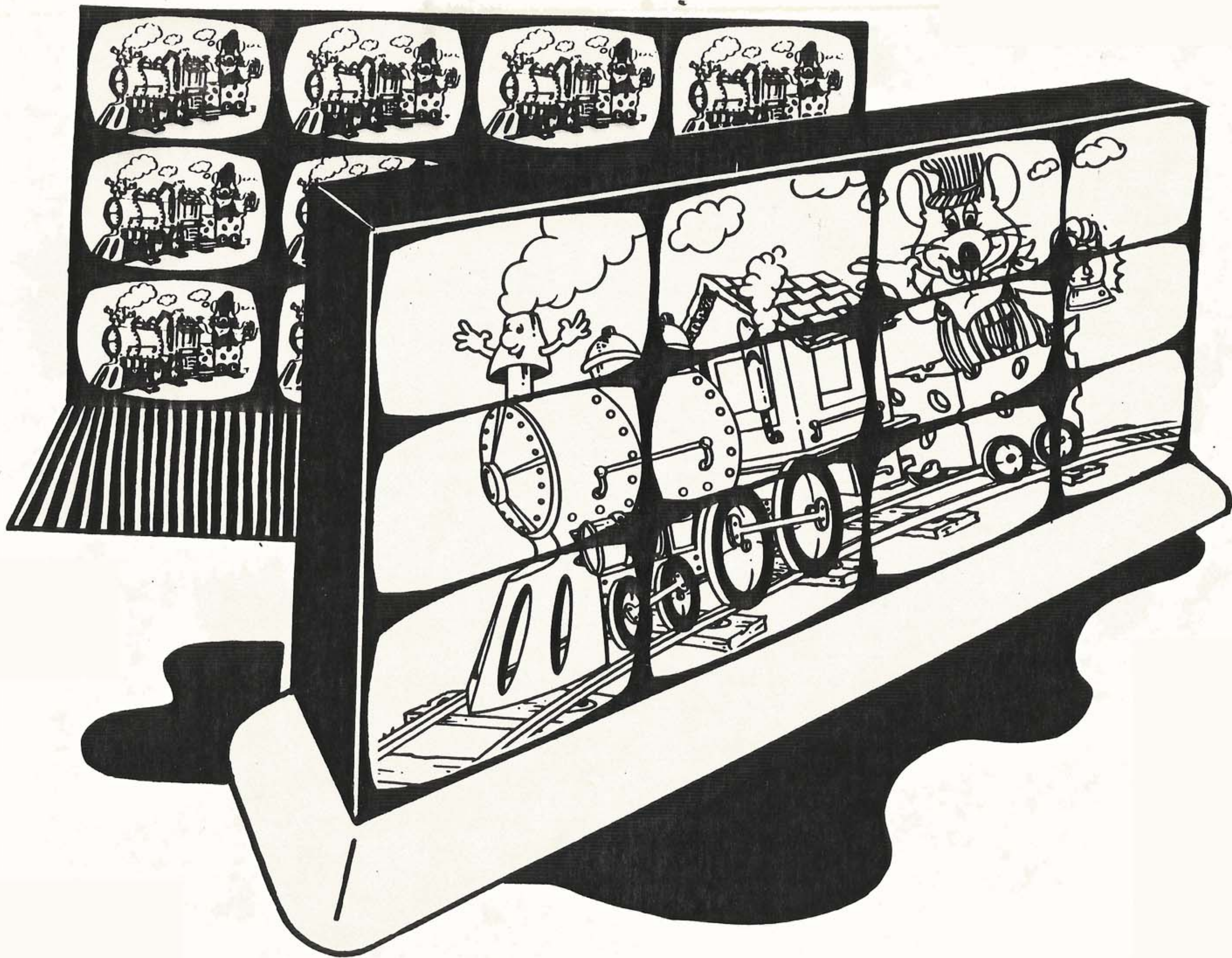



October 31, 1986

PAUL A. LINDEN
SHOWBIZ PIZZA TIME, INC.
4441 W. AIRPORT FREEWAY
IRVING, TEXAS 75062

RE: Quote for 3x3 video wall system for
ShowBiz Pizza Time, Inc.

100 ea. 3X3 Video Wall System to Include:

- 1 ea. Meiko MVP w/matrix and capability
for 3x magnification or single
monitor display and one NTSC
input.
- 9 ea. Hitachi 22" monitor/receivers
- 9 ea. Custom monitor rack for CRT
- 1 ea. Lot video cable from matrix
to CRT
- 1 ea. EPROM control or PC computer
control.

TOTAL PER SYSTEM.....\$30,000

DELIVERY: 120 DAYS FOB DALLAS, TEXAS.

SYSTEM HAS ONE YEAR WARRANTY GUARANTEE ON ALL PARTS.
KIMBALL AUDIO VIDEO, INC. WILL STOCK AND PROVIDE ALL
BACK/UP PARTS FOR SYSTEMS.

NOTE: DOES NOT INCLUDE ANY APPLICABLE STATE SALES TAX.

Sincerely,

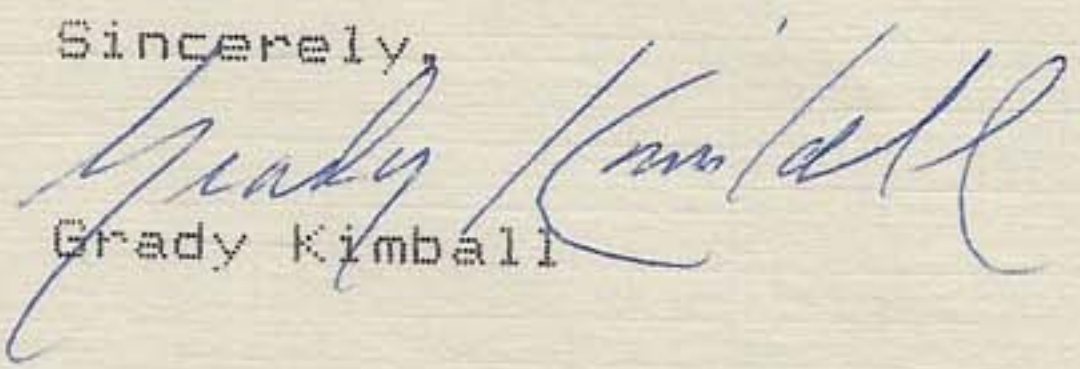

Grady Kimball

Kimball Audio-Video Inc.

11496 Luna Road, Suite K • Dallas, Texas 75234 • 214/869-0117

ANALYSIS OF NEW ATTRACTION POTENTIAL

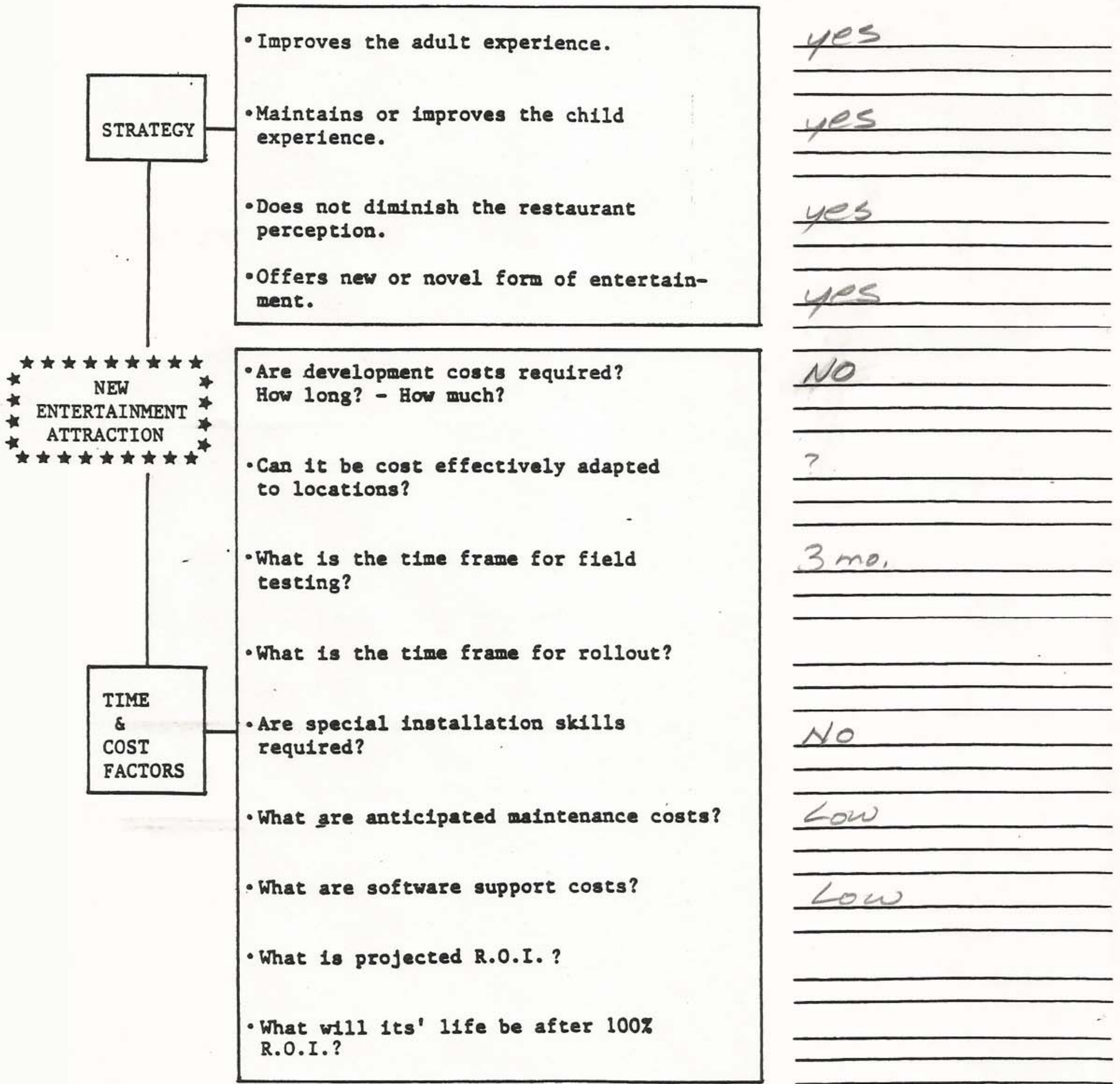
Spec. Events VIDEO



security close-up

Taking the mystery out of CCTV lens selection

By Aaron Chesler

Determining all the necessary parameters for CCTV lens selection, including focal length, field of view and tube size, may seem difficult at first, but it doesn't need to be. This month's column is intended to teach the basics of lens operation and lens selection. Its goal is to take the mystery out of CCTV lens selection.

The purpose of the CCTV lens is to focus the reflected light from a scene onto the camera's light sensing element. (See Figure 1.) This light sensing element, either a tube or solid-state device, converts this reflected light into electrical energy, which is then converted into a TV picture.

The lens works by refraction or the bending of light beams. Refraction occurs because light travels slower in the denser glass medium. When light strikes a glass plate at right angles, it is slowed when traveling through the glass, but emerges on its original path as shown in Figure 2. The change in velocity is indicated by the crowding of wavelengths inside the glass.

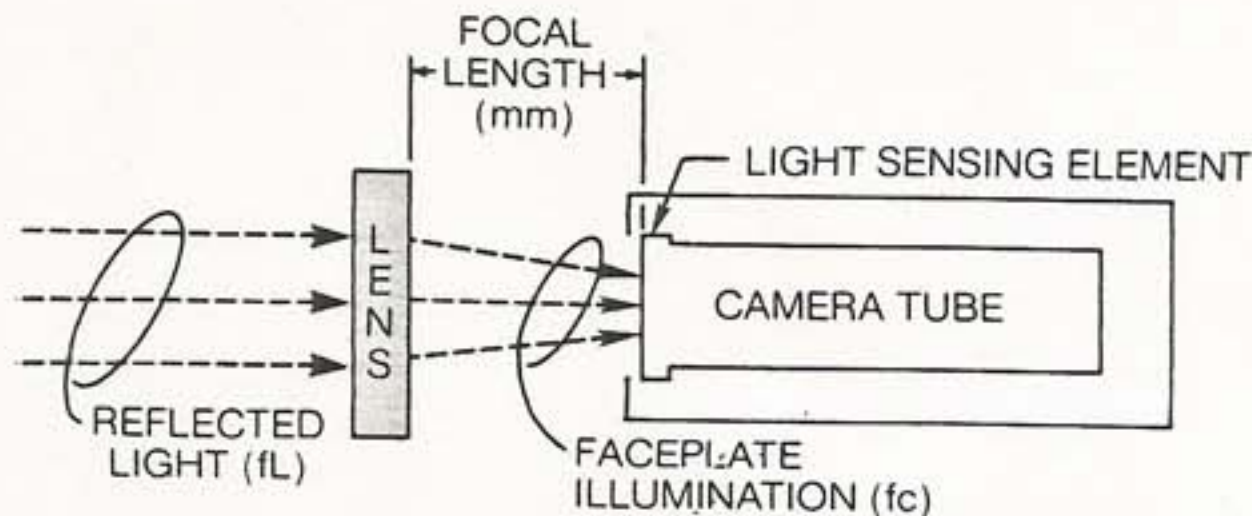

Figure 1. The flow of reflected light from a scene into a TV picture.

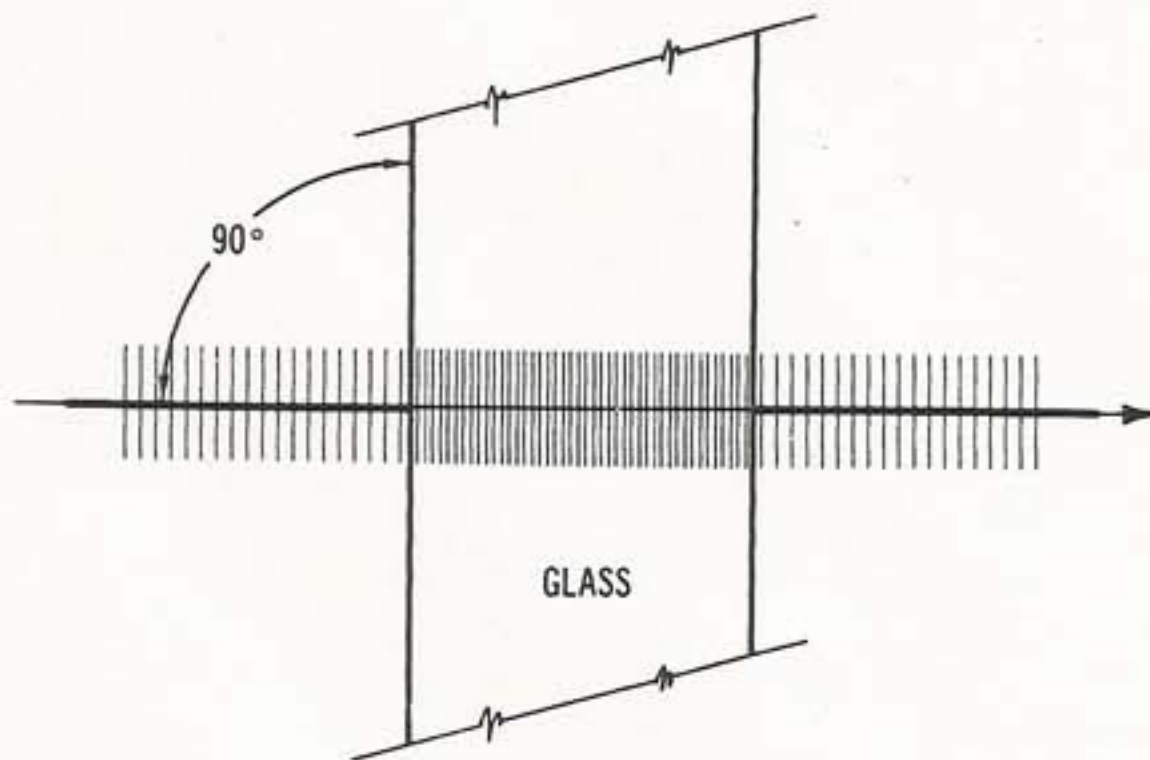

Figure 2. The refraction of light as it travels through glass.

When the beam strikes at an angle, as shown in Figure 3, it is bent toward a perpendicular to the glass surface at the point of entry. The reason is that the wavefronts at the bottom of the beam begin slowing earlier. Upon exiting the glass, the wavefront bends away from the normal. In optical terms, the normal is a line drawn perpendicular to the surface of the lens.

Figure 4 shows that the lens must be manufactured in such a way as to refract the waves of reflected light causing them to focus on the camera's pick-up area.

The characteristics of the lens will determine the camera's field of view (how much of the total scene

appears in the TV picture), depth of field (the distance measured from the camera at which objects appear in focus), and the amount of light, reflected by the scene, that falls on the light sensing element.

A critical measurement of a lens is its focal length, which is the distance between the light sensing element and the center of the lens, and is expressed in millimeters (mm). The greater the focal length, the larger the image will appear. Therefore, the greater the focal length, the more the lens becomes telephoto in application. The change in focal length affects the camera's horizontal and vertical field of view.

An important factor to remember is that cameras with different pick-up tube sizes (such as 1/2 inch, 2/3 inch and one inch), using the same focal length lens, will each give a different field of view. (See Table 1.) If a lens designed for a smaller format pick-up device is placed on a larger one, the results will be a shaded effect around the picture.

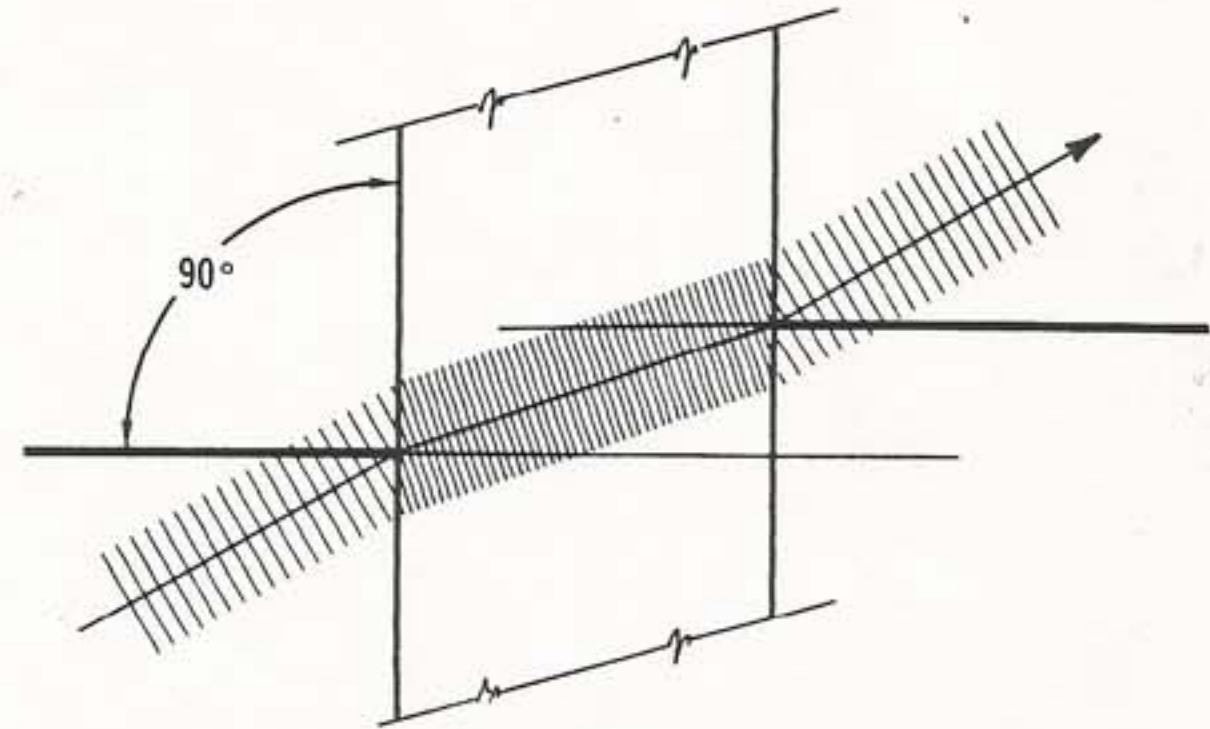

Figure 3. A diagram showing the refraction of light at an angle.

Table 1.
Variance in field of view

Tube format	1"	3/4"	1/2"
Lens focal length	25mm	25mm	25mm
Camera distance from subject	100 ft.	100 ft.	100 ft.
Field of view (Horizontal)	48 ft.	32 ft.	24 ft.

Another determining factor is the lens' *f* number. This is the measurement of the ratio between the focal length (the distance between the camera's sensing element and the center of the lens), and the lens' opening diameter. The smaller the *f* number, the larger the opening and the faster the lens (or the more light the lens will transmit). The *f* number determines the amount of reflected light that reaches the camera's light sensing element.

When choosing a lens for a particular application, you must first determine the size of the area to be viewed (field of view). If you want to make a positive identification, for example, a person's face at a great distance, a telephoto lens will be required. On the other hand, just to view general movement at the same distance, a smaller focal length lens will do the trick. However, for those instances,

Chesler is systems sales manager for the closed-circuit video equipment division of Panasonic, Secaucus, NJ.

Calculating what lens to use

Below are three sets of formulas, one set for each of the most commonly used pick-up device formats. You can easily use the formulas for determining the proper lens size for your application. To more thoroughly demonstrate how to use the formulas, two examples are provided.

W: Width of object (in feet)
 H: Height of object (in feet)
 L: Distance between camera and object (in feet)
 F: Required focal length (in mm)

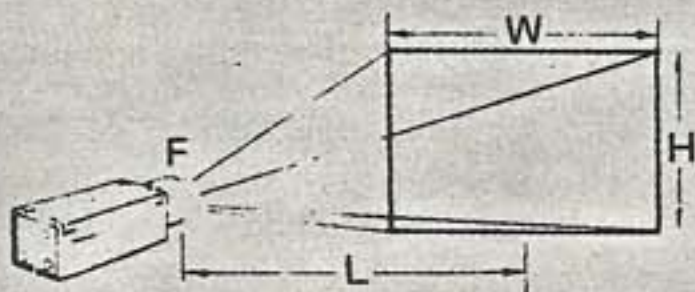

1/2-inch formula

$$F = \frac{6.2L}{W} \quad F = \frac{4.65L}{H}$$

$$W = \frac{6.2L}{F} \quad H = \frac{4.65L}{F}$$

2/3-inch formula

$$F = \frac{8.8L}{W} \quad F = \frac{6.6L}{H}$$

$$W = \frac{8.8L}{F} \quad H = \frac{6.6L}{F}$$

1-inch formula

$$F = \frac{12.7L}{W} \quad F = \frac{9.5L}{H}$$

$$W = \frac{12.7L}{F} \quad H = \frac{9.5L}{F}$$

Problem 1: The owner of a steel company wants a camera to view the entrance gate into his parking lot. The location of the camera from the gate is 100 feet; the desired horizontal field of view is 25 feet.

Let's assume that a 1-inch tube format CCTV camera has already been chosen. We want to figure what size lens is required.

Procedure: From the 1-inch tube camera chart, choose the formula for determining the required focal length. The formula indicated is:

$$F = \frac{12.7L}{W} \text{ or focal length (in mm) = } \frac{12.7 \times \text{distance between camera and object}}{\text{width of object (in feet)}}$$

Solution: $F = \frac{12.7 \times 100 \text{ (feet)}}{25 \text{ (feet)}}$ or $F = 50.8 \text{ mm}^*$

Problem 2: A customer had decided to relocate an existing 2/3-inch tube camera with a 16mm lens to a new location. The camera's new location is on a wall viewing a parking garage that extends 85 feet to the other side.

What will the camera's horizontal field of view be when viewing the opposite wall?

Procedure: From the 2/3-inch camera chart, choose the formula for determining the required horizontal field of view (width of object). The formula indicated is:

$$W = \frac{8.8L}{F} \text{ or width of object (in feet) = } \frac{8.8 \times \text{distance between camera and object}}{\text{focal length (in mm)}}$$

Solution: $W = \frac{8.8 \times 85}{16}$ or $W = 46.75 \text{ feet}$

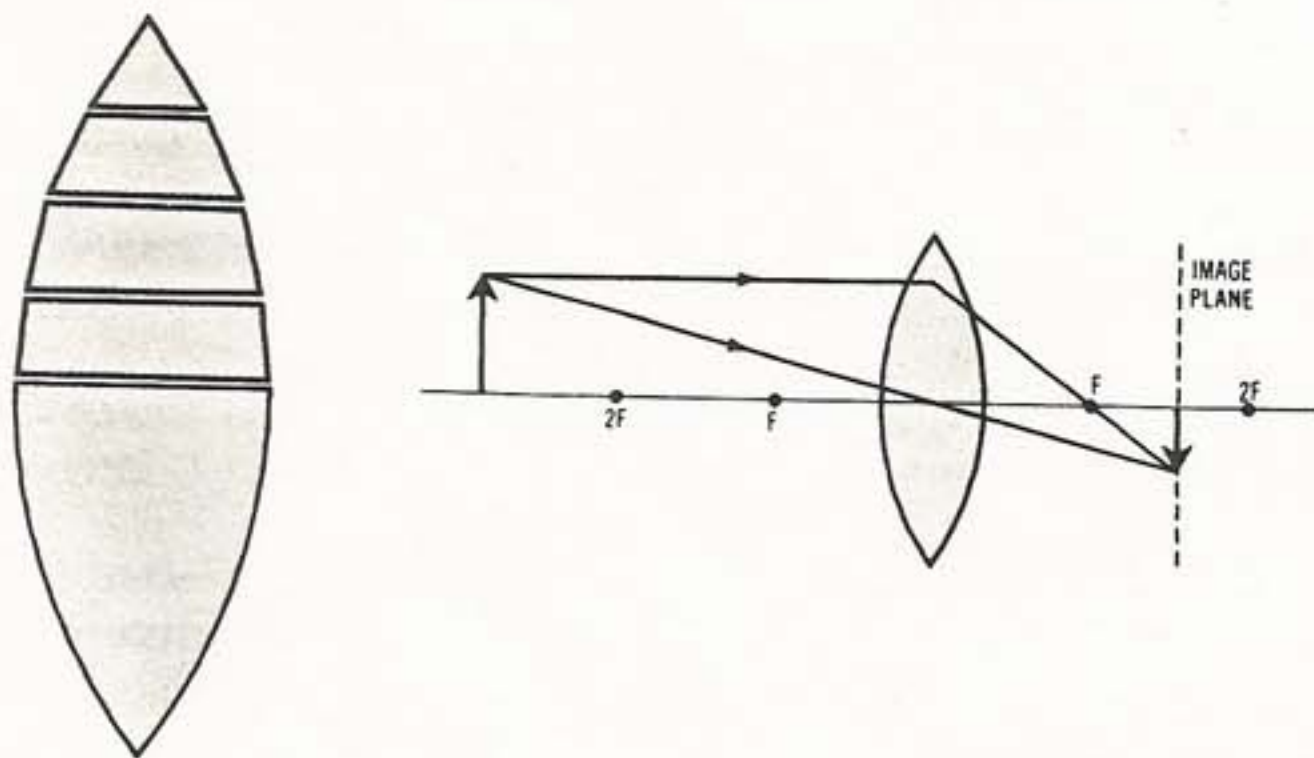

Figure 4. A camera lens must refract light so that it focuses on the camera's pick-up area.

where you want a general overview and at the same time still want to obtain a positive identification, a zoom lens should be used. The purpose of a zoom lens is to provide you with a variable focal length, from wide angle to telephoto.

Once you have determined the size of the area to be viewed, the next step is to calculate the camera's distance from the area or object under surveillance. The final factor, as mentioned earlier, is the size of the camera's pick-up device. With these three pieces of information: area or object size, distance from camera to object, and pick-up device size, you can now choose your lens.

The sidebar, "Calculating What Lens To Use," provides various formulas and examples that will help you to determine field of view and lens selection.

S&VC



**Multi-Camera
special effects
right in the palm
of your hand.**



Only from SciTech.

SEG-11

The least expensive modular SEG in the market. For two color cameras; a rugged, reliable and very compact unit that features built-in cuts, dissolves, and accepts 20 optional plug-in modules.

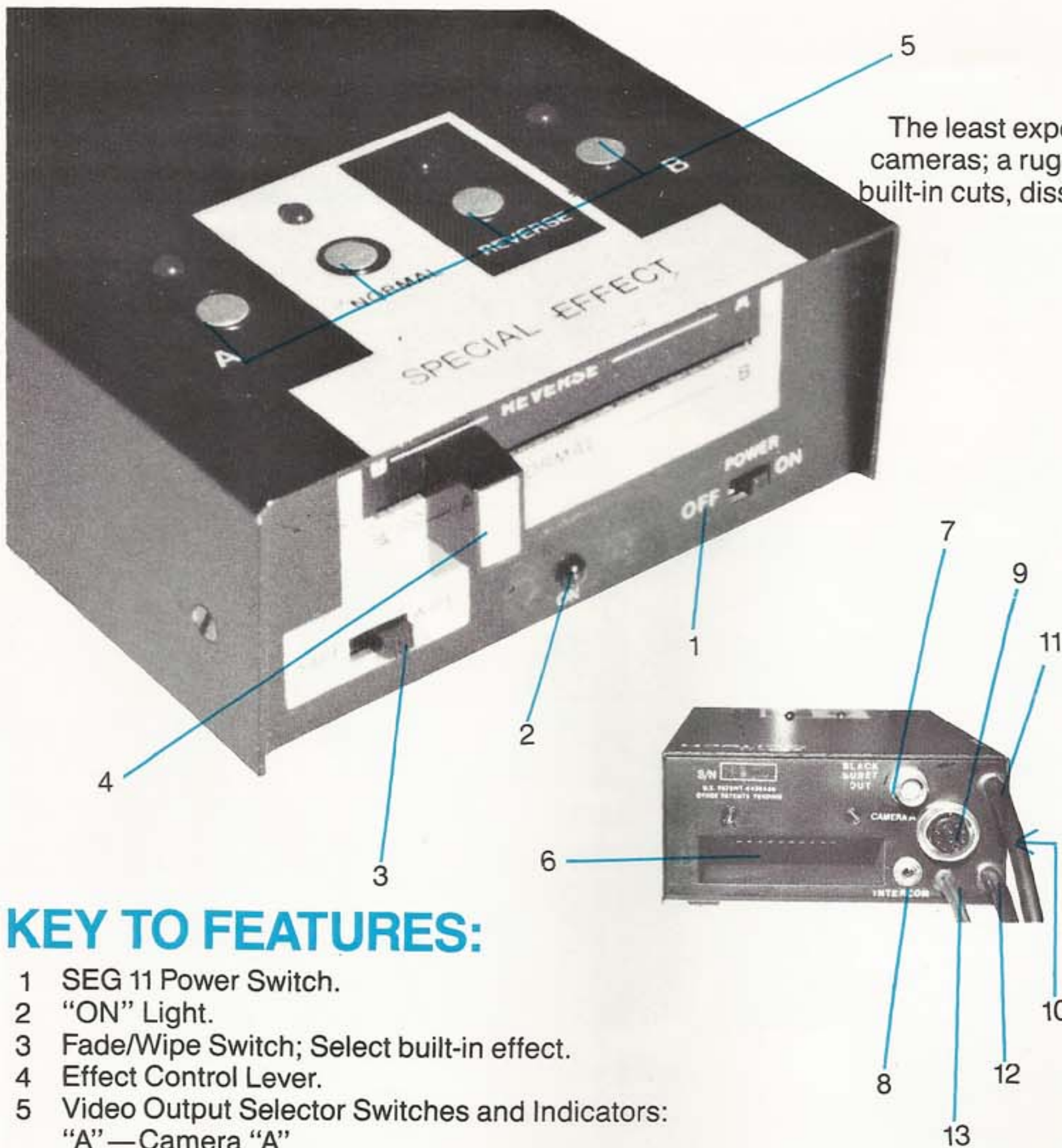

KEY TO FEATURES:

- 1 SEG 11 Power Switch.
- 2 "ON" Light.
- 3 Fade/Wipe Switch; Select built-in effect.
- 4 Effect Control Lever.
- 5 Video Output Selector Switches and Indicators:
"A" — Camera "A"
"B" — Camera "B"
Normal — Mix A & B
Reverse — Mix B & A
- 6 Special Effect Module Cartridge Slot.
- 7 "Genlock Out" Connector. See Tech. Specs. (pg. 6)
- 8 Intercom Jack. For optional IH-11 SciTech Intercom only.
- 9 Camera "A" Jack.
- 10 Monitors Connector.
- 11 Camera "B" Cable.
- 12 VCR Output Cable.
- 13 Power Cable.

- Requires one camera with built-in genlock or SciTech camera upgrade and N-2 GenClock. (See page 6).
- Stereo Hi-Fi and Audio-Follow-Video standard.
- Light and portable; weighs only 1.8 lbs., measures only 8" x 4-3/8" x 2".
- Power requirement: 12 volt, 0.35 A.
- Professional soft-touch buttons.
- Accepts all SciTech accessories, including EU-3 Expansion Board.

TECHNICAL SPECIFICATIONS:

VIDEO INPUT:	1 V.p.p., NTSC RS-170-A (U.S. Standard) Camera A: 10 pin connector. Camera B: 13 pin + 8 pin cable connector.
AUDIO INPUT:	Line level (-20 db), 1 Kohm + .
VIDEO OUTPUT:	1 V.p.p. over 75 Ohms on 10 pin cable connector. No power taken from VCR.
GENLOCK OUTPUT:	Black burst, 0.4 V.p.p. over 75 ohms on BNC connector.
AUDIO OUTPUT:	Line level on 10 pin cable connector. Stereo. Right & left.
POWER:	11 to 14 Volts DC, 350 mA., power for both cameras and SEG-11 through 3.5 mm connector. Both cameras power through SEG
SIZE:	8" x 4-3/8" x 2" (203 x 111 x 51 mm).
WEIGHT:	1.8 lb. (0.81 kg).

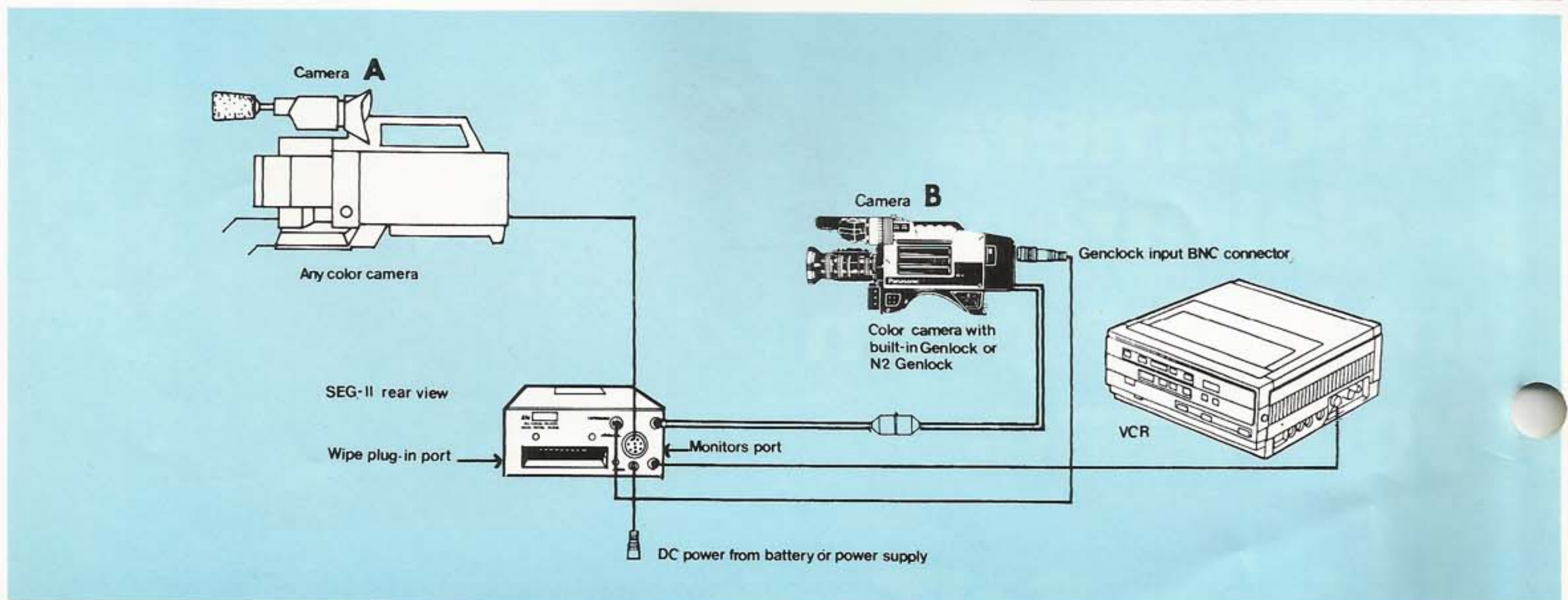

SEG 21

The only modular Special Effect Generator-Genlock combo on the market that will allow you to create completely professional special effects with two off-the-shelf consumer color cameras. Features built-in genlock, cuts and dissolves. Accepts 20 optional plug-in special effect modules.

- Requires one Magnavox VR8282BK, VR8283BK or JVC GN-X80U camera or one SciTech camera upgrade on one of your own cameras.
- Stereo Hi-Fi and Audio-Follow-Video standards.
- Light and Portable: only 1.8 lbs., measures 8" x 4-3/8" x 2".
- Power requirement: 12 Volts, 0.35 A.
- Professional soft-touch buttons.
- Accepts all SciTech accessories, including EU-3 Expansion board.

TECHNICAL SPECIFICATIONS:

VIDEO INPUTS: 1 V.p.p., NTSC RS-170-A (U.S. Standard). Camera A: 10 Pin connector. Camera B: 13 pin + 8 pin cable connector
AUDIO INPUTS: Line level (-20 db) 1 Kohm + .

VIDEO OUTPUT: 1 V.p.p. over 75 ohms on 10 pin cable connector. No power taken from VCR.

GENLOCK OUTPUT: Compatible with Magnavox VR8282BK, VR8283BK or JVC GN-X80U Genlock input. Other cameras modifiable by SciTech. Not compatible with cameras with built-in genlock.

AUDIO OUTPUT: Stereo. Line level on 10 pin cable connector. Right and left.

COLOR MATCHING: 0 to 360 degree SC Phase, user adjustable independent of cable.
H. PHASING: Automatic, independent of cable.

POWER: 11 to 14 Volts DC, 350 mA., power for both cameras and SEG-21 through 3.5 mm connector. Both cameras power through SEG 8" x 4-3/8" x 2" (203 x 111 x 51 mm).
SIZE:
WEIGHT: 1.8 lb. (0.81 kg).

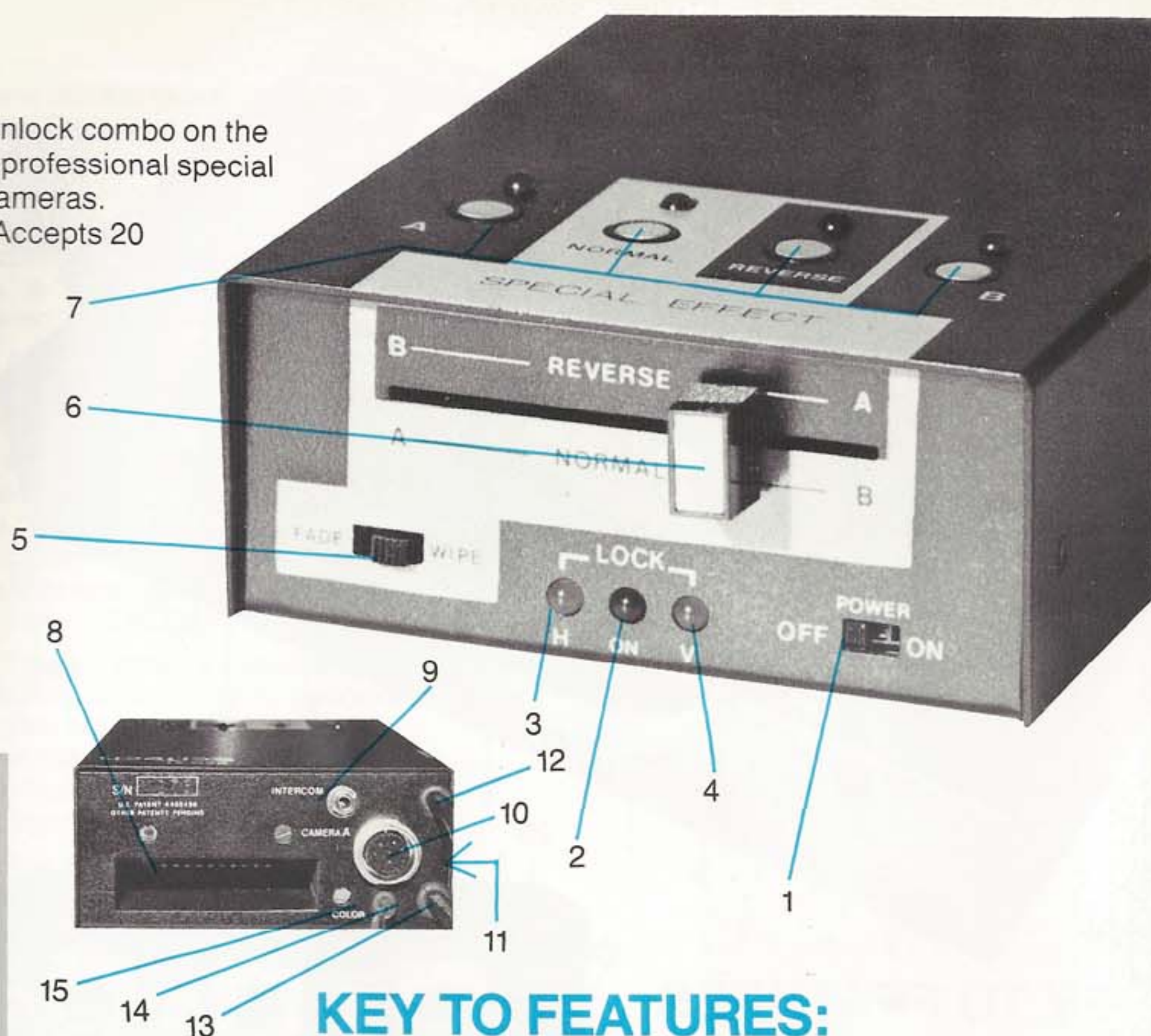

KEY TO FEATURES:

- 1 SEG 21 Power Switch.
- 2 "ON" Light.
- 3 "H" Lock Light.
- 4 "V" Lock Light.
- 5 Fade/Wipe Switch; Select built-in effect.
- 6 Effect Control Lever.
- 7 Video Output Selector Switches and Indicators: "A"—Camera "A" "B"—Camera "B" Normal—Mix A & B Reverse—Mix B & A
- 8 Special Effect Module Cartridge Slot.
- 9 Intercom Jack. For optional IH-21 SciTech Intercom only.
- 10 Camera "A" Jack.
- 11 Monitors Connector.
- 12 Camera "B" Cable.
- 13 VCR Output Cable.
- 14 Power Cable.
- 15 Color Matching Adjustment.

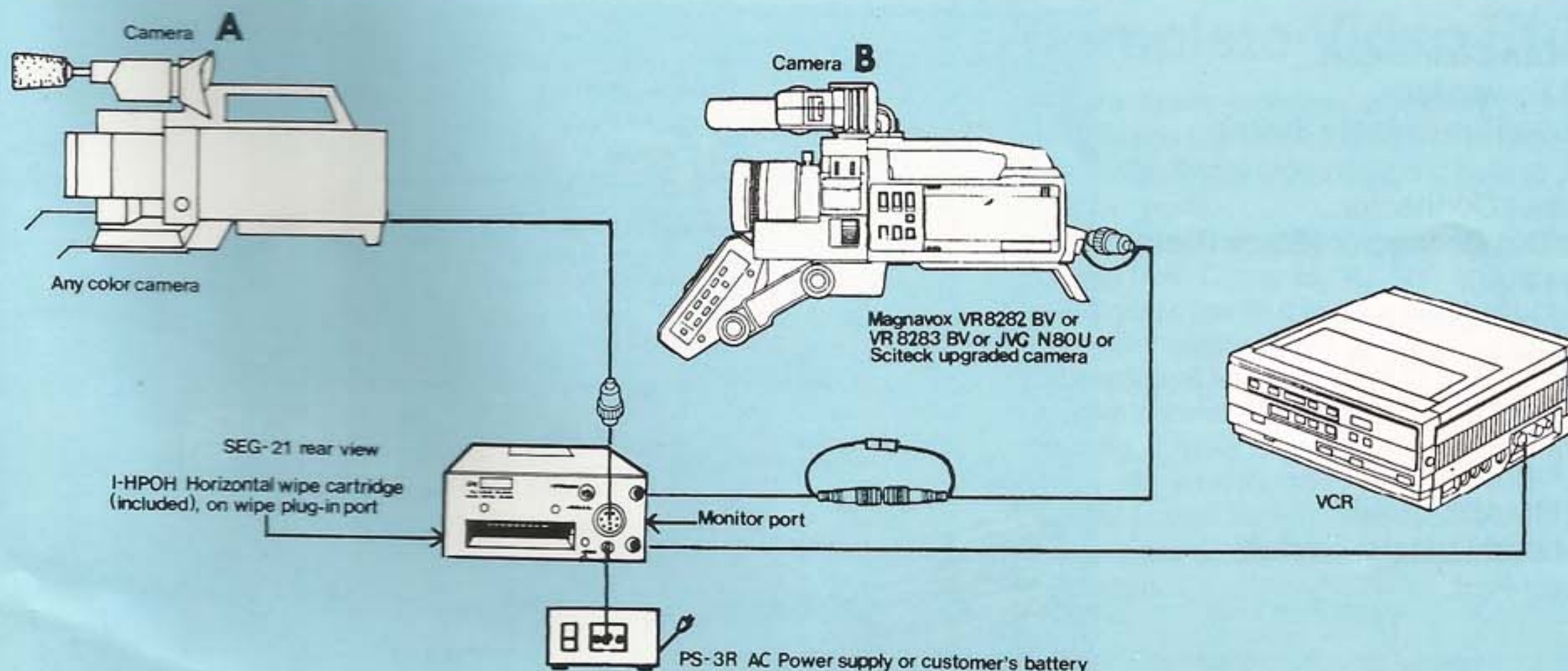

SEG 31

Our complete portable studio for two or more color cameras. Includes built-in cuts, dissolves, horizontal, vertical and corner wipes. Features speed auto-wipe and fade to black. Accepts 20 optional Special Effect Modules.

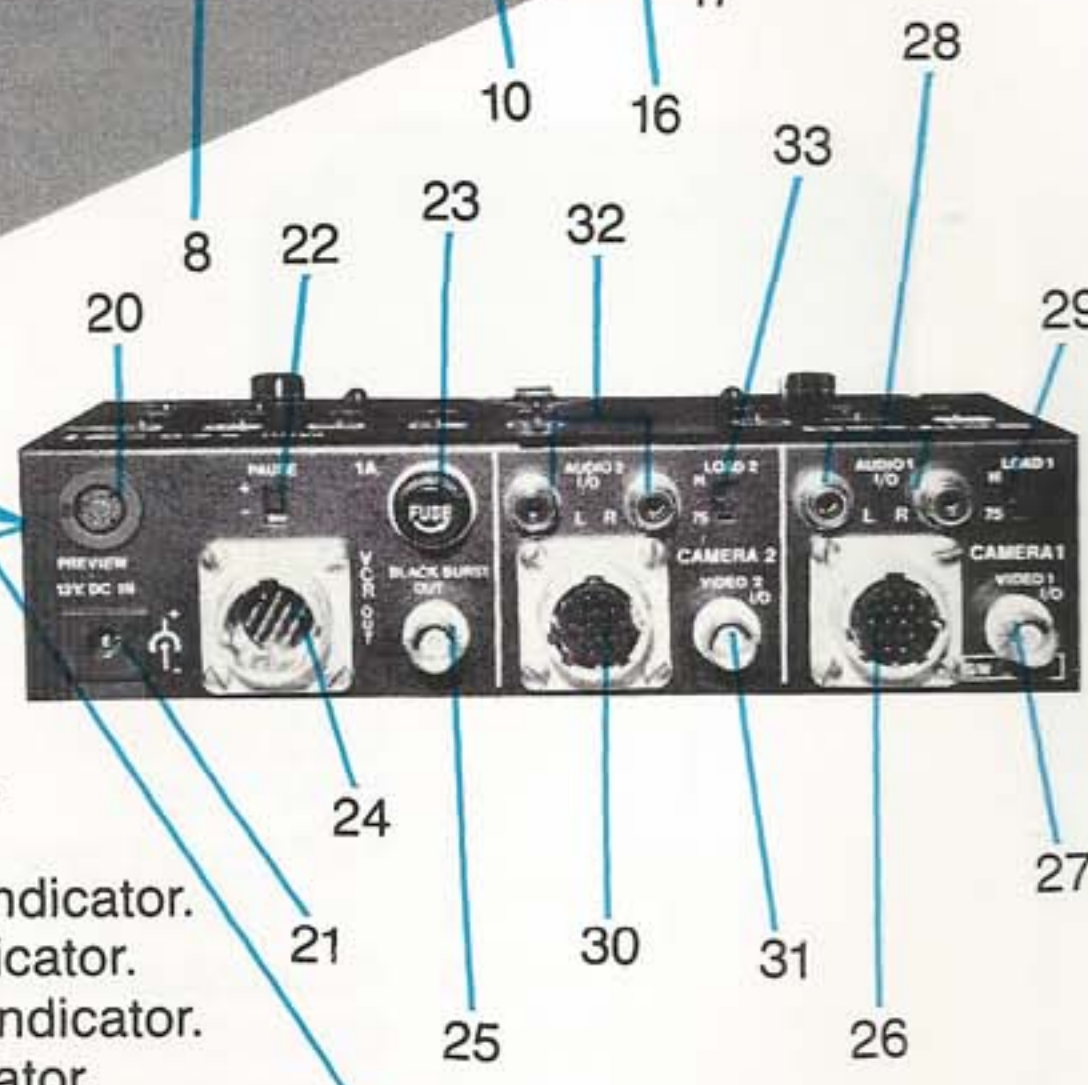
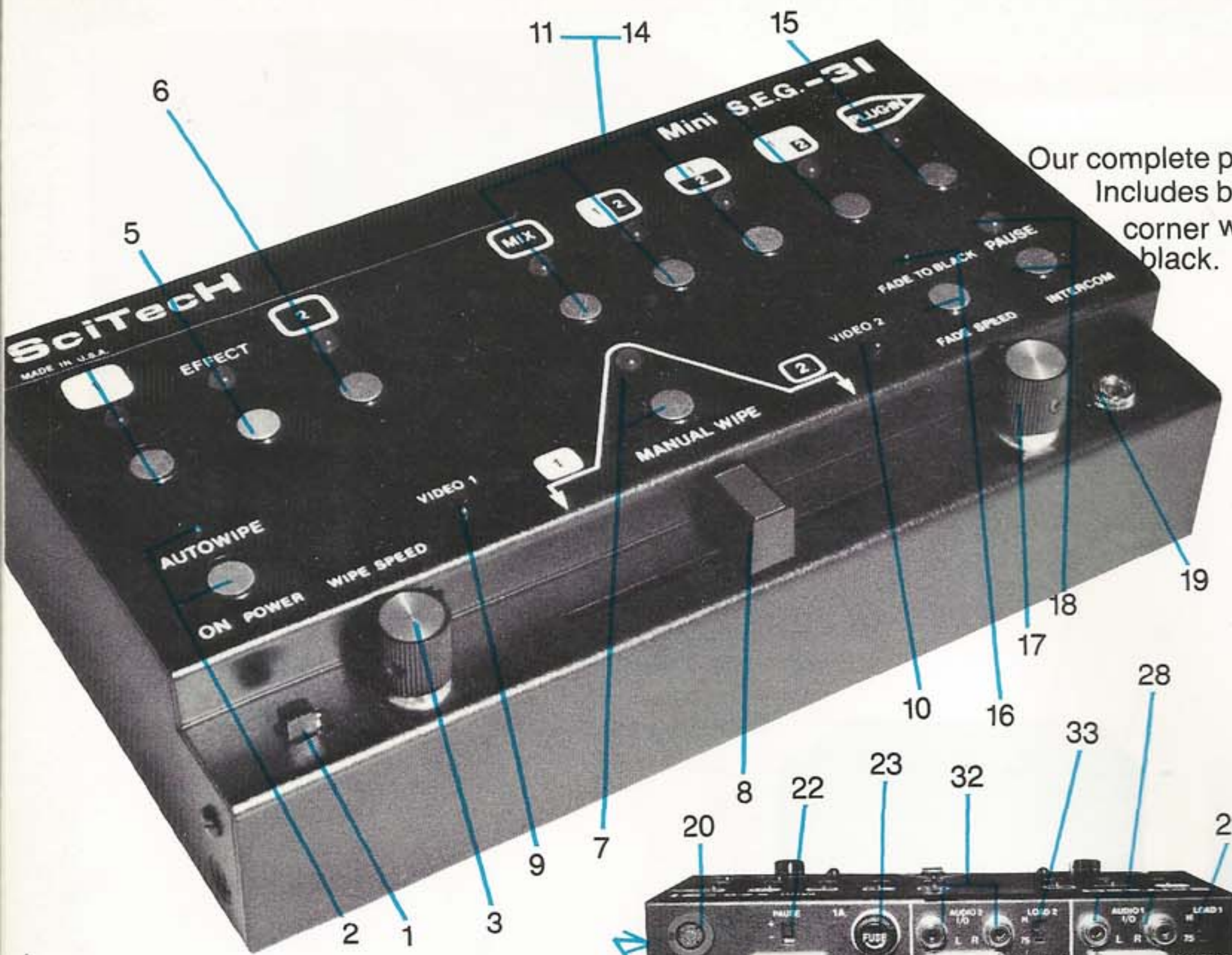

KEY TO FEATURES:

- 1 Power Switch.
- 2 Autowipe Switch and LED Indicator.
- 3 Autowipe Speed Control.
- 4 Video Input "1," Selector, and LED Indicator.
- 5 Effect Output Selector and LED Indicator.
- 6 Video Input "2," Selector, and LED Indicator.
- 7 Manual Wipe Switch and LED Indicator.
- 8 Manual Wipe Control Lever.
- 9 Video "1" LED Indicator.
- 10 Video "2" LED Indicator.
- 11 Fade Effect Selector Switch and LED Indicator.
- 12 Horizontal Wipe Selector Switch and LED Indicator.
- 13 Vertical Wipe Selector Switch and LED Indicator.
- 14 Corner Wipe Selector Switch and LED Indicator.
- 15 Expansion Port Selector Switch and LED Indicator.
- 16 Fade-to-Black Switch and LED Indicator.
- 17 Auto Fade-to-Black Speed Control.
- 18 VTR Start/Stop Switch and LED Indicator.
- 19 Intercom Jack.
- 20 Preview-Out Connection.
- 21 External Power Jack.
- 22 VTR Pause/Run Polarity Switch.
- 23 Fuse.
- 24 VTR Output Connector.
- 25 Genlock-Out Connector (Black Burst).
- 26 Camera 1 Input.
- 27 Video 1 Input/Output.
- 28 Audio 1 Inputs/Outputs.
- 29 Video 1 Load Selector Switch.
- 30 Camera 2 Input.
- 31 Video 2 Input/Output.
- 32 Audio 2 Inputs/Outputs.
- 33 Video 2 Load Selector Switch.
- 34 Expansion Port.

- Requires one camera with built-in genlock or SciTech camera upgrade and N-2 GenClock on one of your cameras.
- Stereo Hi-Fi and Audio-Follow-Video standard.
- Professional soft-touch buttons.
- Accepts complete line of SciTech accessories including EU-3 Expansion Board.
- Light and portable. Only 2.2 lbs., measures 8" x 4.6" x 2".
- Power requirements 12 volts, 0.35A.
- Preview output of special effect video.
- Intercom amplifier, headset jack and volume control built-in.

TECHNICAL SPECIFICATIONS:

- VIDEO INPUTS:** 1 V.p.p., 75 ohms or High Z, switchable, 14 pin and BNC connectors.
- AUDIO INPUTS:** Stereo at -20 db, 14 pin and RCA connectors.
- VIDEO OUTPUT:** 1 V.p.p., 75 ohms on 14 pin connector only.
- GENLOCK OUTPUT:** Black burst, 0.4 V.p.p., 75 ohms, on 14 pin Camera "2" connector and separate BNC connector.
- AUDIO OUTPUTS:** Stereo, -20 db. on 14 pin connector only.
- SYNC:** From Camera "1" video input, no internal sync. provided.
- POWER:** 11 to 14 volts DC, 350 mA., (without options).
- SIZE:** 8" x 4.6" x 2" (203 x 117 x 51 mm).
- WEIGHT:** 2.2 lbs. (1 kg.).

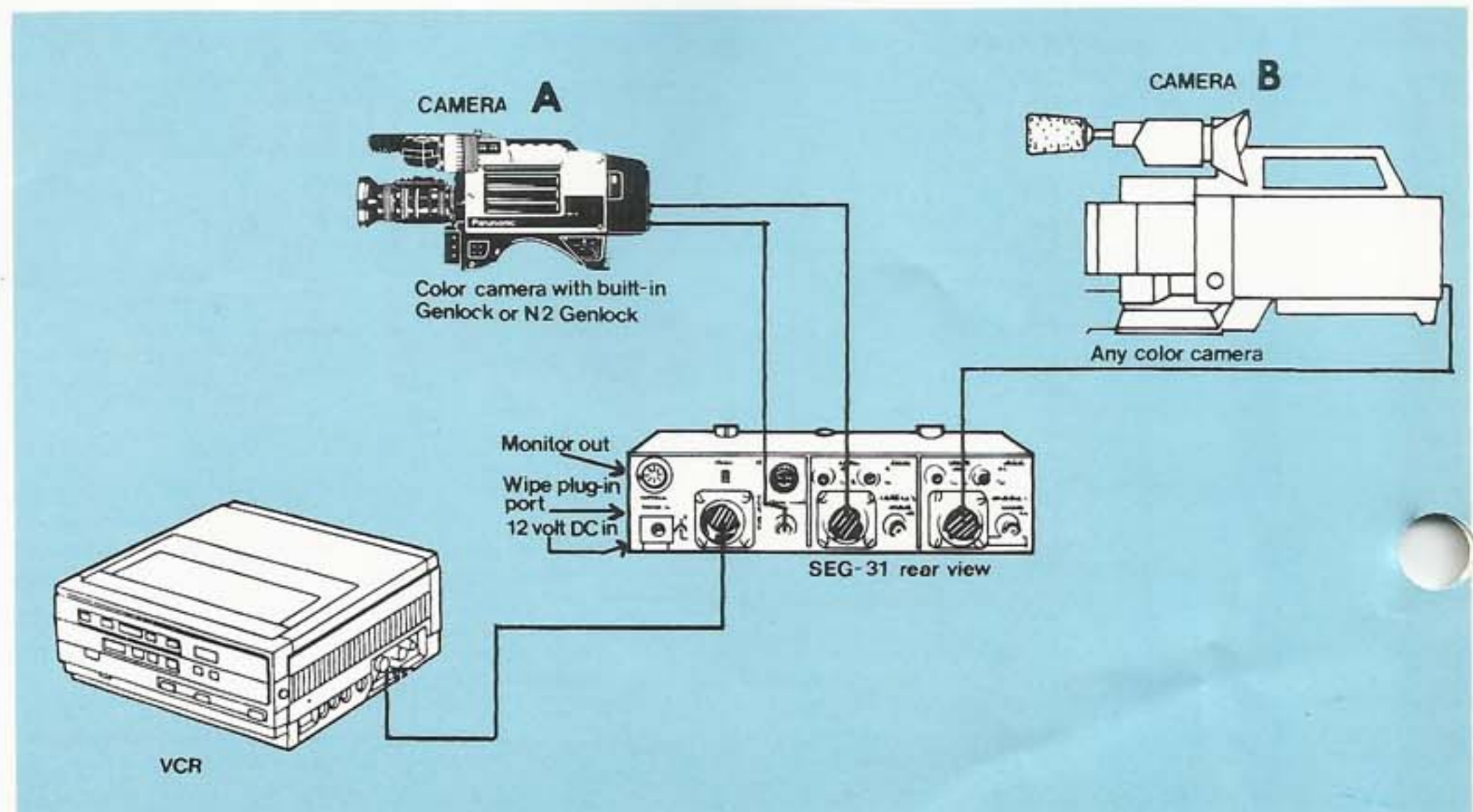

Why you need "genlock" to produce special effects with two video cameras.

The theory of video special effects is surprisingly simple!

Take two cameras, for example, "A" and "B." If you want to produce a special effect, say, putting the video from "B" in a little square inside the video from "A," you just take the signal from "A," and, at the appropriate time and place, "cut" a little "hole" in that signal. In that "hole," you put the signal from "B" and that's it. You have just created a special effect!

Trouble begins when you are asked to put this theory into practice.

Video signals, as you probably know, are formed by an electron beam traveling along the 525 lines of your TV screen in 1/30th of a second and forming the patterns of shapes and colors that our eyes interpret as movement.

To produce a special effect—basically, cutting an image into another—both electron beams, from Camera "A" and Camera "B" must

be traveling through exactly the same place at exactly the same time. There is no room for error.

Referring to our illustration, the electron beam from Camera "A" and the electron beam from Camera "B" must cover the same distance from "x" to "y" in exactly the same time period "1" to "2."

Any small deviation from that synchronicity and the effect is off. The result: complete chaos.

When the three components of a video signal ("H" for Horizontal, "V" for Vertical and "SC" for Color Subcarrier Frequency) are perfectly, exactly synchronized, they are said to be in "GENLOCK."

Figure 3 shows a special effect resulting from a correctly genlocked signal: half the final image comes from Camera "A," half from "B," yet, the final line is continuous and straight.

The ability to genlock-synchronize two cameras is commonplace in the expensive world of professional video...but practically unknown in the more accessible world of "home" video.

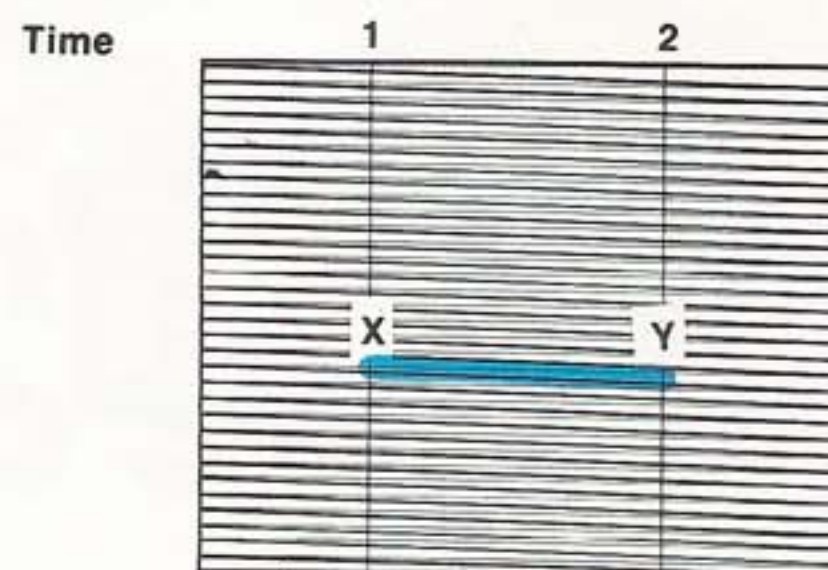

Video from "A"

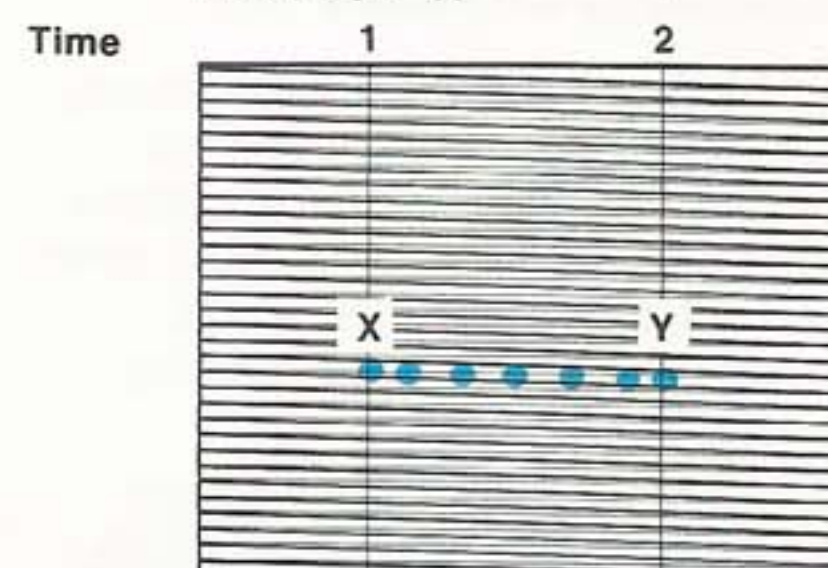

Video from "B"

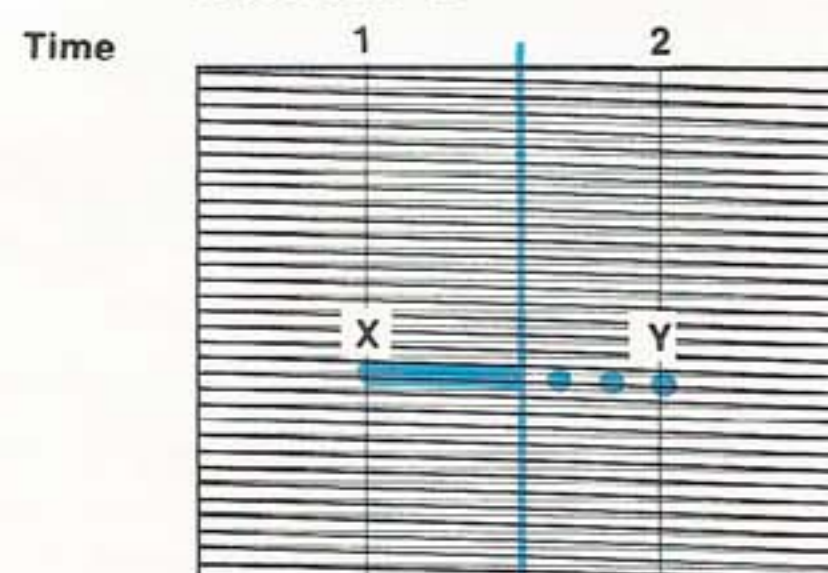

Video from "A" Video from "B"

Genlocked video—"A" & "B" mixed successfully

TECH NOTE: Why you can't plug your VCR into your SEG...yet.

Many of our customers have called or written asking whether they can use their VCR's in conjunction with their SEG's to obtain the same high quality professional special effects they are now accustomed to.

The answer, sadly, is no.

SciTech's SEG's, like any other Special Effect Generators, can not use direct VCR playback video signals due to the inherent instability of these video sources.

Normally, one industrial-type Time Base Corrector—also known as TBC—is required to correct each VCR's video signal before the SEG gets it.

Already in the works, however, is SciTech's revolutionary low cost Time Base Equalizer and Corrector (TIBEC), which will fulfill the functions of two TBC's.

Naturally, your present SEG (and any other equipment you buy from

us) will be fully compatible with our TIBEC. You will then be able to obtain professional special effects using your own home VCR!

We will inform all our customers as soon as the unit is commercially available.

This notice is given for information purposes only and in no way implies an obligation by SciTech to manufacture and/or sell the new device referred to above at any time or price.

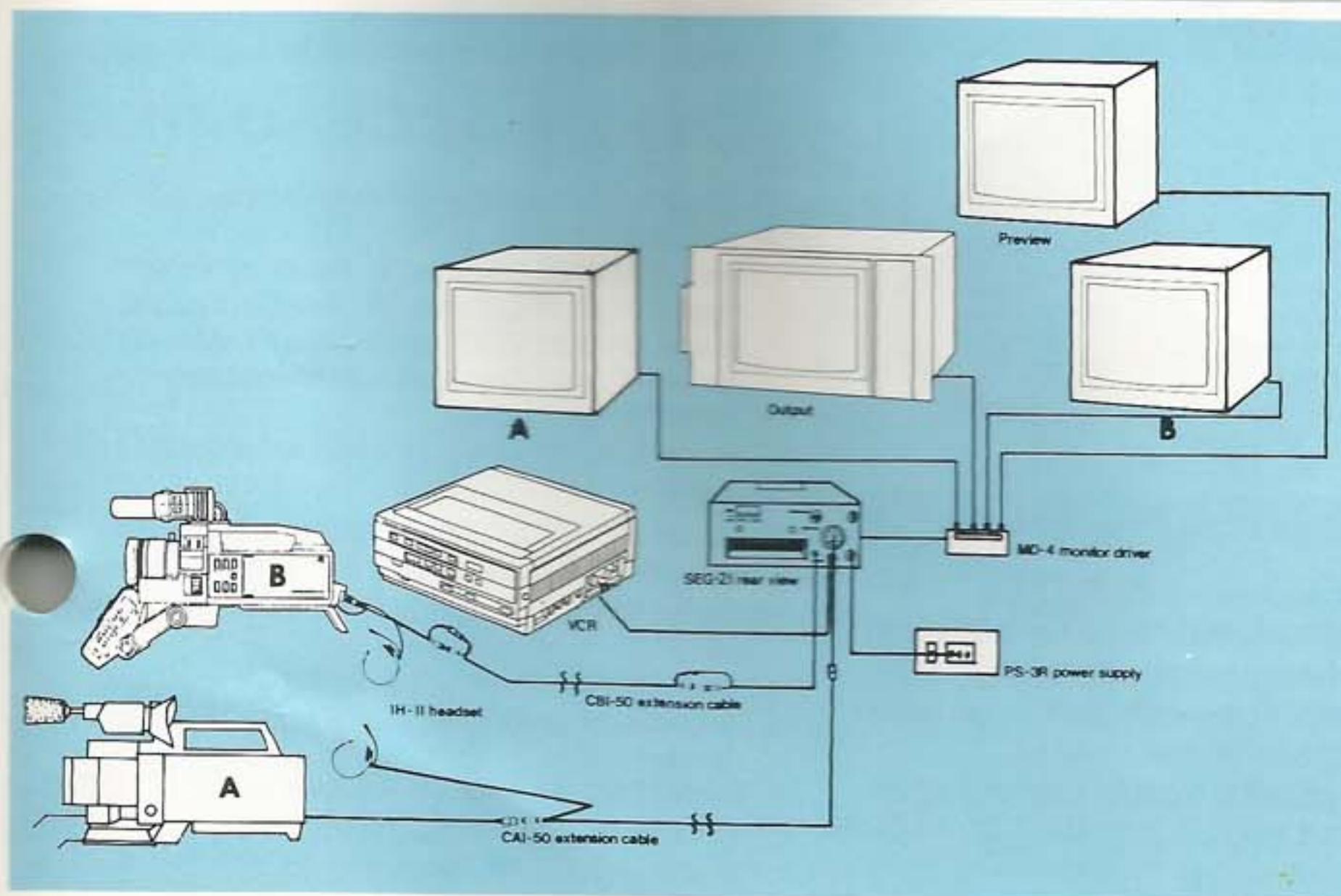

Complete Video Studio.

The practically unlimited versatility of SciTech's SEG line lets you start with the basic system; grow to a fully professional video studio...built to your own special needs.

Handle two color video cameras and control the outputs from Cameras "A," "B" and Special Effect before you commit it to your tape! Your SEG Special Effect Generator allows you to drive up to four monitors (with optional MD-4 Monitor Driver) for complete creative control. Run the show the way you like... instantly, thanks to your SEG's intercom capability. Then, take it on the road with our ADUPS Uninterruptible Power Supply. Your SEG studio lets you concentrate on the most important part of your video: the image.



N-2 GENCLOCK

SciTech's N-2 GenClock transforms virtually any modern color camera into a genlock camera ready for special effects generation. Use it with your own video camera, any other unmodified, off-the-shelf camera and a special effect generator to begin creating professional looking effects.

- Requires SciTech Camera Upgrade (see below).
- Fully automatic operation; requires no controls or adjustments.
- Comes with one phono-plug and phono-plug video cable.

TECHNICAL SPECIFICATIONS:

VIDEO STANDARD:	NTSC Color Interlaced Video.
EXTERNAL VIDEO:	1 V.p.p., 75 ohms, or 5K depending on "LOAD" switch setting.
HORIZONTAL SYNC:	200 nanoseconds maximum "H" Alignment.
ACCURACY:	Full frame sync on interlaced video.
VERTICAL SYNC:	Fully automatic, on correct subcarrier cycle and phase.
SUBCARRIER SYNC:	Fully automatic, on correct subcarrier cycle and phase.
POWER (from camera supply):	12 volts, less than 250 mA.
SIZE:	6.8" x 4" x 1.75" (173 x 102 x 44 mm)
WEIGHT:	1.6 lbs. (0.73 kg)
REQUIRED CAMERA UPGRADE:	Because most consumer video cameras are not prepared to receive a genlock unit, SciTech must modify one of your cameras (to be used as Camera "B") by adding an external "Genlock Input Connector." The N-2 GenClock then plugs into this GIC carrying the oscillator lock and reset signals to the camera. Because this upgrade does not modify in any sense the inner workings of your camera, it works normally when not using the GenClock Unit.

PLUG-IN SPECIAL EFFECT MODULES.

Let your imagination fly! Add versatility and creativity to your videos with 20 different plug-in special effect modules. Use singly or with EU-3 Expansion Board. Patented design for quick changing. Rugged construction assures easy, trouble-free connections.

MODEL WIPE DESCRIPTION

1-HPUH		Horizontal Wipe
1-HPUV		Vertical Wipe
2-HPUR		Upper Right Hand Corner
2-HPUL		Upper Left Hand Corner
2-HPLR		Lower Right Hand Corner
2-HPLL		Lower Left Hand Corner
2-HPDH		Double Horizontal
2-HPDV		Double Vertical
2-HDLR		Diagonal Left-Right
3-HPSR		Squeeze Right
3-HPSL		Squeeze Left
3-HPST		Squeeze Top
3-HPSB		Squeeze Bottom
3-HDUC		Dual Upper Corners
4-HPSQ		Square
4-HPQC		Quad Corners
4-HEHS		Dual "H" Squeeze
4-HDVS		Dual "V" Squeeze
4-HDCL		Diagonal Corners
4-HDLC		Dual Corners



EU-3 EXPAN. BOARD

The perfect accessory for SciTech's entire SEG line! Allows instantaneous switching from up to three special effect modules.

- Professional soft-touch button operation.
- Smooth, glitch-free transitions.
- Rugged, reliable, trouble free operation.
- Compatible with SEG-11, SEG-21, SEG-31.

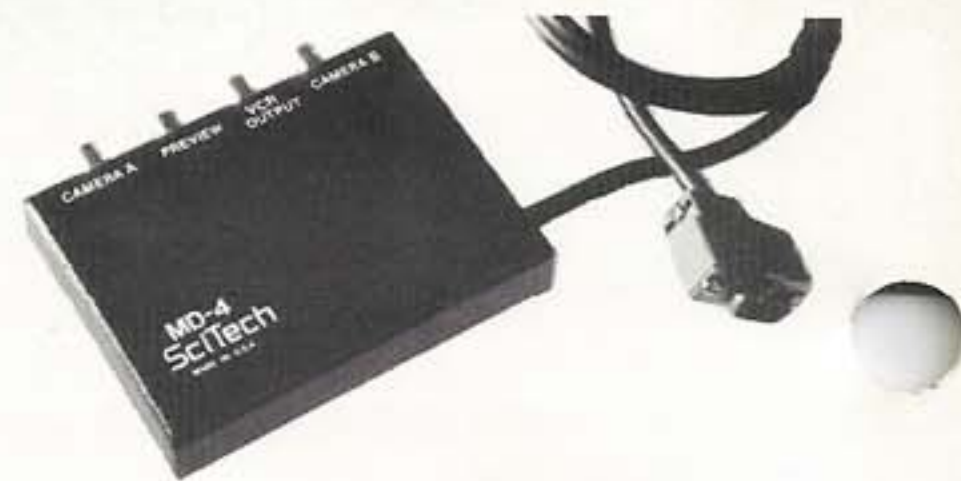

MD-4 MONITOR DRIVER

For SEG-11 and SEG-21. Four video outputs on RCA jacks; Camera "A," Camera "B," Preview and Output to set up your own TV studio. Use on video monitors or with separate RF modulators on any B&W or Color TV set.



VIS-4 SWITCHER.

Plugs directly into the "Monitor Out" port of the SEG-11 or SEG-21. Use mounted on camera accessory shoe or in equipment table. Allows you to monitor video from either Camera "A," "B," Output Video or to preview special effects before recording them. Professional soft-touch buttons and LED indicators for jump-free switching.

AWP-15 AUXILIARY VIEWFINDER.

Use in conjunction with VIS-4 Switcher to preview video from Camera "A," "B," Output or Special Effect in sunlight.

IH-11 INTERCOM SET and CAMERA EXTENSION CABLES.

IH-11 plugs directly into any of your SEG units. Battery-powered, professional quality unit features individual volume control and switch. Lightweight and comfortable for extended wearing.

CAI-50, CBI-50-11 AND CBI-50-21 are 50' long intercom-wired extension cables for use with Camera "A" and Camera "B." Also available, 100' length. Other lengths available by special order.

OTHER ACCESORIES:

ADUPS Uninterruptible Power Supply. 15 Amps, 12 volts.

Model BCA-21 Camera "A" Breakout cable.

Model BCB-21 Camera "B" Breakout cable.

Model BVC-21 VCR Out Breakout cable.

Model CLA-21 Cigarette lighter adapter (12 to 15 volts).

Model CBC-21 Color bar chart for accurate color adjustment.

Model BVC-31 5 ft. VCR breakout cable, VNC video to RCA audio, 3 over 32" seconds pause.

Model BVC-31-10 5 ft. Adapter cable for VHS VCR with EIAJ 10 pin camera plugs.

Model BVC-31-14E 5 ft. Adapter cable for 3/4" Industrial or Broadcast VCR's with EIAJ 14 pin camera plugs.

Model BVC-31-14S 5 ft. Adapter cable for VCR's with plastic 14 pin Beta camera plugs.

The Ultimate in Multi-Camera Convenience! SciTech's Portable Mobile Studio System.

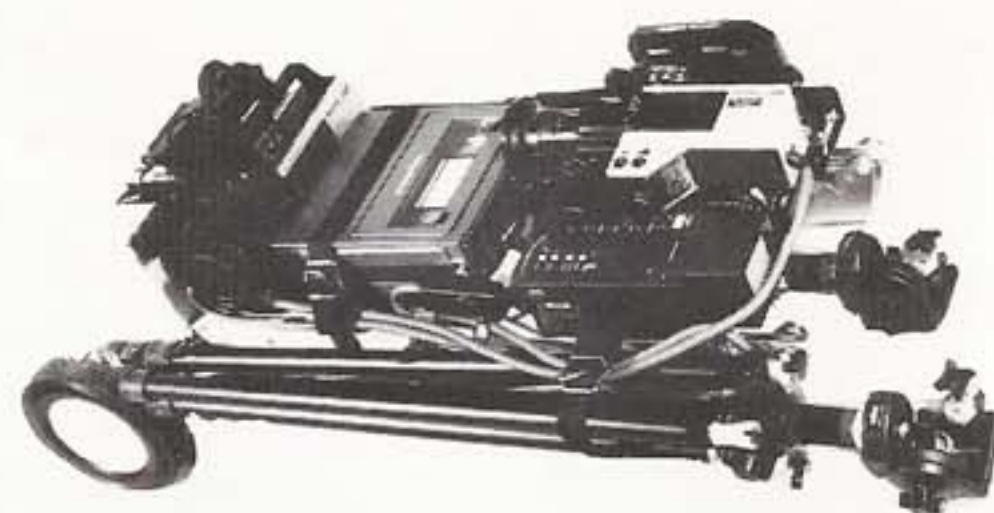
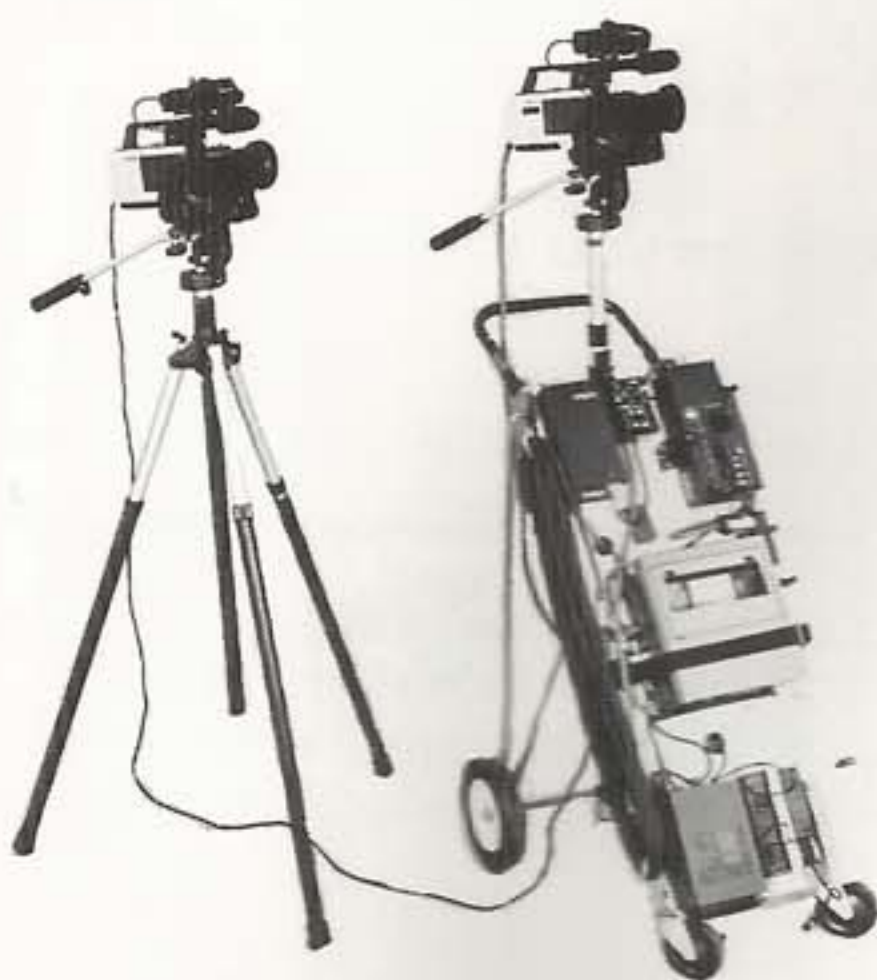

With SciTech's SEG-based Portable Mobile Studio Systems, you have the ultimate mini-TV studio.

All VC-SEG Mobile Systems handle two color video cameras; come complete with one VCR and one or three (depending on model) color monitors driven by our VIS-4 switcher. Our ADUPS AC/DC Uninterruptible Power Supply gives you the freedom of complete mobility. And, since they come fully packed and ready to run, you just have to add your choice of cameras and...go!

The rugged aluminum folding cart allows you to operate equally at ease indoors or outdoors, on a studio or anywhere else. It folds neatly and securely with all equipment connected. Folded, it will fit in the trunk of most cars, even compacts.

EQUIPMENT AND CONFIGURATION

COMPONENT	MODEL VC...		SEG-11		SEG-21		SEG-31	
	1	3	1	3	1	3	1	3
Special Effect Generator			SEG-11		SEG-21		SEG-31	
Genlock			N-2		N/A		N-2	
ADUPS Uninterruptible Power Supply and rechargeable battery	1	1	1	1	1	1	1	1
1-HPUH Horizontal Wipe Cartridge	1	1	1	1	—	—	—	—
VIS-4 Four Channel Monitor Driver	1	—	1	—	—	—	—	—
MD-4 Four Monitor Driver	—	1	—	1	—	—	—	—
DA-1 Preview Monitor 75 Ohm Adaptor	—	—	—	—	1	1	1	1
VSC-1 Cart Assembly, including brackets, cleats and wiring	1	1	1	1	1	1	1	1
CAI-50 Camera "A" Extension cable, intercom-wired, coiled on cleats.	1	1	1	1	1	1	1	1
CBI-50 Camera "B" Extension cable, intercom-wired, coiled on cleats.	1	1	1	1	1	1	1	1
IH-11 Intercom Set.	2	3	2	3	2	3	2	3
CPTCC Cart Mounted Monopod Column	1	1	1	1	1	1	1	1
CPT Tripod with Cart Holders for transportation.	1	1	1	1	1	1	1	1
TV Camera Fluid Effect Head (Mounted on tripod and monopod)	2	2	2	2	2	2	2	2
UVC TM-P3U, 2.7 Dual Input Color Monitor and DC Cable Adapter	1	3	1	3	1	3	1	3

All VC Portable Mobile Systems are shipped fully tested and partially disassembled by SciTech. Complete assembly and wiring instructions are included. Available only as listed.

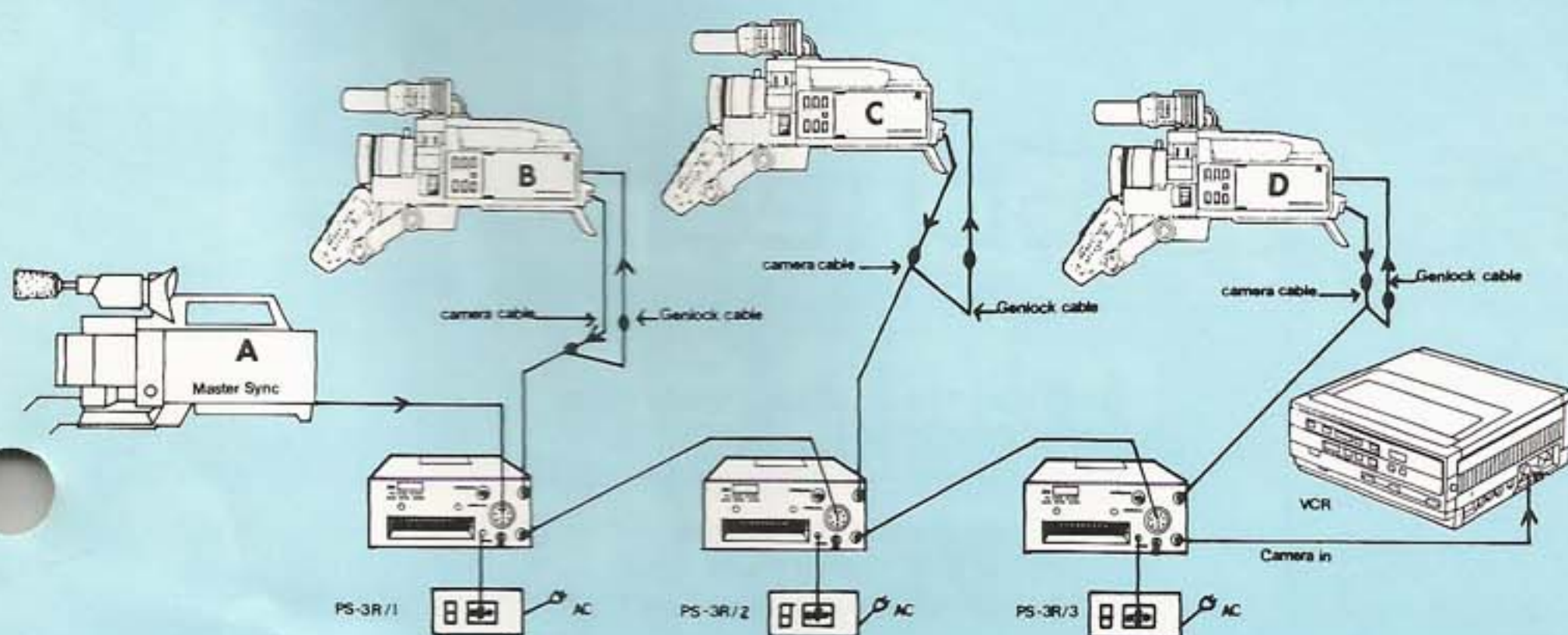

When two cameras are not enough.

You can take full advantage of our SEG-21 virtually limitless expansion capability by creating your own multi-camera set up.

Since the SEG-21 is both, a Special Effect Generator and a Genlock unit, it is possible to daisy-chain (cascade) several units to obtain arrangements like the one shown here.

In this example, SEG-21 #1's output is connected to the Camera "A" input of SEG-21 #2 which, in turn, is connected into the Camera "A" input of SEG-21 #3. Their respective cameras "B" are termed "C" and "D," with the VCR output on SEG-21 #3 connected to the VCR. By using the appropriate Special Effect Modules (2-HPUR, 2-HPLL, 2-HPLR), it becomes possible to have one monitor share all the four cameras.

Only SciTech's SEG line allows you this much creative freedom without the large investments previously required for other professional equipment!

Professional capabilities... designed for you.

Whether you are an experienced video pro, an advanced amateur or even a rank beginner, with SciTech's complete SEG line, you'll be producing professional-quality multi-camera special effects right from day one.

They're portable.

So you can take them anywhere you need big-time special effects...without the big time studio crew! From board meetings to sales presentations, from seminars to seminars, SciTech's SEG line delivers.

Produce moving wedding videos, unforgettable birthday parties, convincing sales presentations, professional training films, mini documentaries for you and your clients...with SciTech's SEG line nothing holds back your creativity.

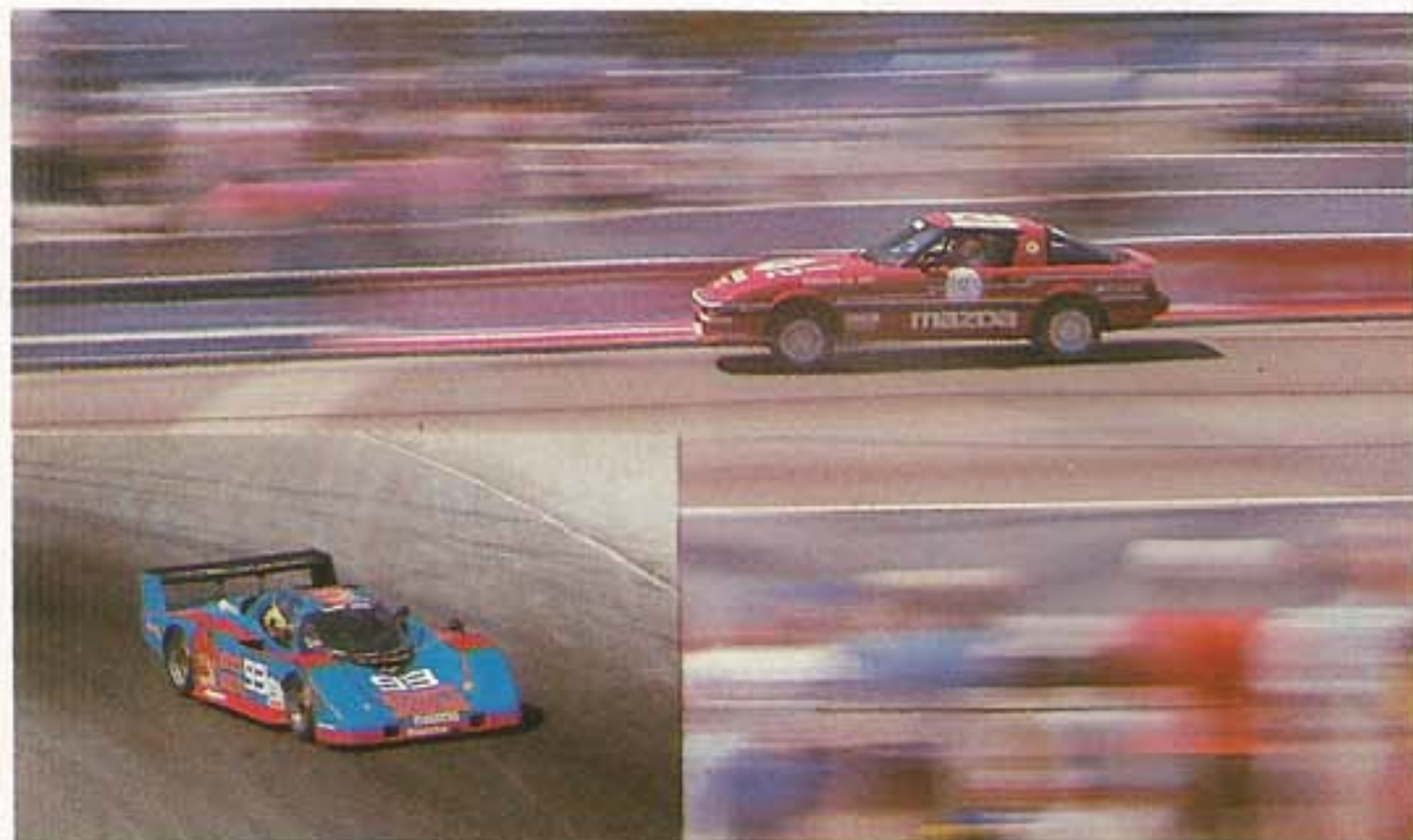

Simplicity of Design.

All SciTech Special Effect Generators are designed and constructed by engineers with a passion for good video and lasting quality. They are easy to use, almost instinctive. All controls are easy to reach and use, resting at your fingertips. Nothing prevents you from concentrating on the most important part of your video: the image.

Rugged Construction.

All our Special Effect Generators and accessories feature rugged aluminum construction; oversized and overbuilt to take the worst professional challenges day after day and still deliver the sharp, brilliant, trouble-free images you demand.

Our quality detailing include soft-touch buttons and smooth-sliding switches for glitch-free transitions and effects. There are LED indicators for all major functions, heavy duty connections, clinch nuts and solid bolts...all backed up by an even more solid guarantee.

Expansion Capabilities you'll never leave behind.

Choose from twenty special effects now...our unique—and patented—modular set-up allows your SEG virtually limitless expansion capabilities as new special effect modules and optional equipment is introduced.

Customize your SEG by adding new modules, switchers, intercoms, uninterruptible power units, monitor drivers, additional cameras and a complete range of accessories. Our versatile connection layout makes your SEG as individual as you are.

What does the future hold for you and your SEG?

Innovations you can use. Pure and simple. Because with SciTech's "Oscar"-winning design team, already famous for such breakthrough innovations as the Dynalens and two-time winner of the Consumer Electronic Show's Engineering Design award, there is no telling where the future will take you.

Already planned developments include a Time Base Equalizer and Corrector for home VTR's and many more technical innovations that will do more than keep pace with your imagination. They will truly expand it.

All specifications subject to change without notice.

SciTech reserves the right to change, modify or alter any specification on any of its equipment.

SciTech

Bringing real innovation directly to you.

1450 N.W. 78 Ave., Miami, Florida 33126
Tel. (305) 591-1620

Dealer Inquiries welcome.

- For orders or info, call toll free:
1-800-421-4407 (West Coast Time)
1-800-842-0070 (East Coast Time)

SciTech

Model 142 Tibec Time Base Equalizer & Corrector

Now you can build a post-production studio at a fraction of the cost of previous Two-TBC installations.

Mix two VCR's, or one VCR with a camera, computer, laser disk, etc... in beautiful dissolves, wipes and other special effects.

Correct the time base of your tapes for improved stability, less generation losses and professional vertical interval switching.

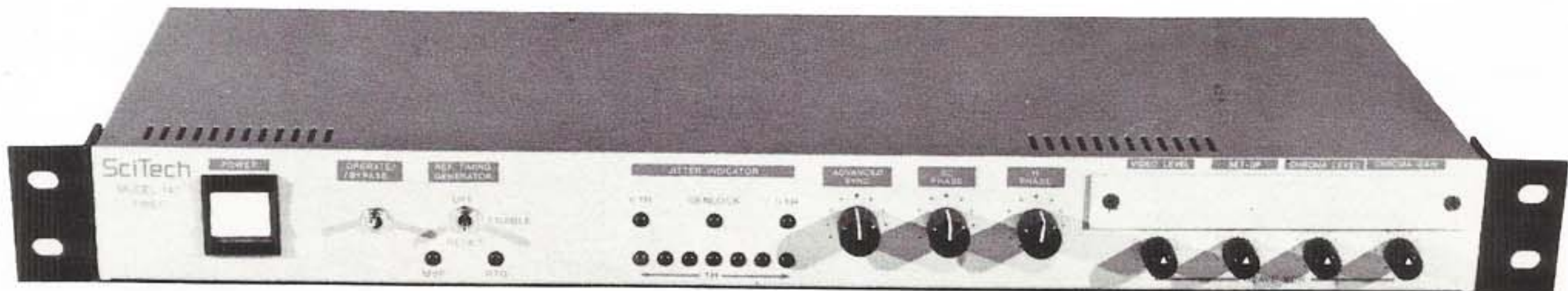

DESCRIPTION

Model 142 is the first TBC capable to correct the Time Base of a VCR playback video to a stable reference OR to equalize it (Make It Equal) the Time Base of another VCR. It can also change the timing of a CR to progressive sync sources such as computers and other interlaced or not, stable or unstable video sources. Dissolves, wipes and other special effects among these sources can be easily performed with a single **Model 142 TIBEC**.

The Time Base Equalization capability of **Model 142 TIBEC** has been described as "impossible" in many technical papers. **SciTech**, a well know innovator and inventor in video and other fields, once again has proven wrong such statements with its new (patent pending) **TIBEC** unit.

Indeed, **Model 142 TIBEC** is also a TBC and can be used as such in all applications where conventional TBC's are used: VCR Time Base Correction to house or internal sync for broadcast or cablecast, satellite transmission, jitter-free duplication, etc. **Model 142 TIBEC** is compatible with all VCR formats, including 3/4", 1/2" VHS or Beta and 8mm.

The new **TIBEC** includes an internal Reference Timing Generator that can be used in free-running mode or genlocked to the Master Video. The Reference Timing Generator automatically replaces the Master Video if such signal loses quality beyond a preset level.

Model 142 TIBEC is equipped with a full feature Video Processor that corrects and enhances the Slave VCR video. An optional Master Processor can be installed on **Model 142** to enhance the Master Video.

The Slave VCR used with **Model 142** must have an **EXTERNAL SYNC** input, as many industrial 1/2" and 3/4" VCRs are. **Model 142** can also drive an **EXTERNAL SUBCARRIER** input if the VCR has one, as many 3/4" VCRs do. For those with VCRs without these inputs, such as all consumer VCRs, **SciTech** plans to offer External Sync and External SC Input installation services for several popular VCR models including VHS, Beta and 8 mm units.

Special Effects Generators used with a **Model 142 TIBEC** operated in TBE mode must be capable to handle unstable and incoherent video signals. All SEG's built by **SciTech** (**SEG-11**, **SEG-21**, **SEG-31**, Comprehensive **MS-2000**, **Magnavox AR9160** and others) can do so, as can some industrial **SEG's** from Panasonic and other manufacturers. Other **SEGs** may or may not operate properly under these demanding conditions, depending on its internal design. Other video equipment used downstream of **Model 142** used in TBE Mode such as character generators, keyers atc., must be capable to operate with the sync of the video source used as **Model 142 Master Input**.

MAJOR FEATURES

- Allows use of Special Effects Generators with two VCRs in playback.
- Replaces two conventional Time Base Correctors for A/B Roll Editing.
- Performs all functions of one conventional TBC.
- Locks VCRs to Non-Interlaced Computers, Laser Disks and Other Sources.
- Genlockable Reference Timing Generator with Gray Burst Output.
- Built-In Slave Video Process Amplifier. Optional for Master Video.
- Compatible with 3/4", 1/2" VHS and Beta, M, Betacam and 8mm. VCRs.
- Operates with one VCR with Ext. Sync OR Ext Sync and Ext SC Inputs.

NOTE: SciTech will offer Ext Sync (and Ext SC) installation services or kits for selected VCR models.



Model 142 TIBEC Rear Panel View

The Unlimited Versatility Of Model 142 TIBEC.

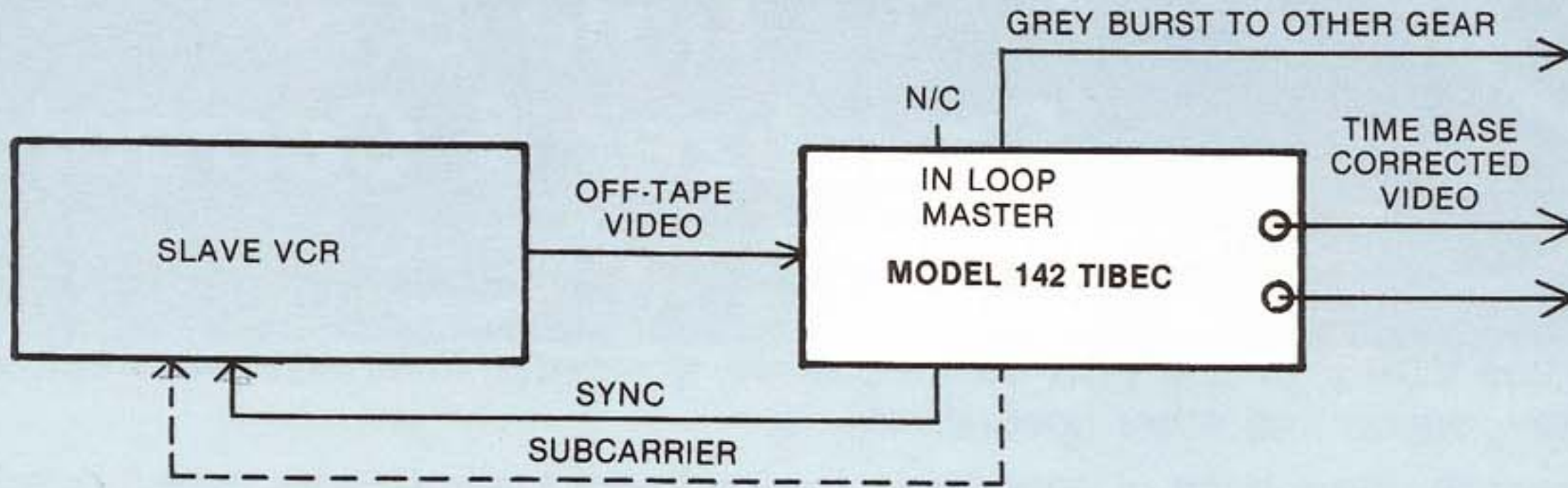

Model 142 TIBEC as a TBC. Correcting to Stable Internal Sync.

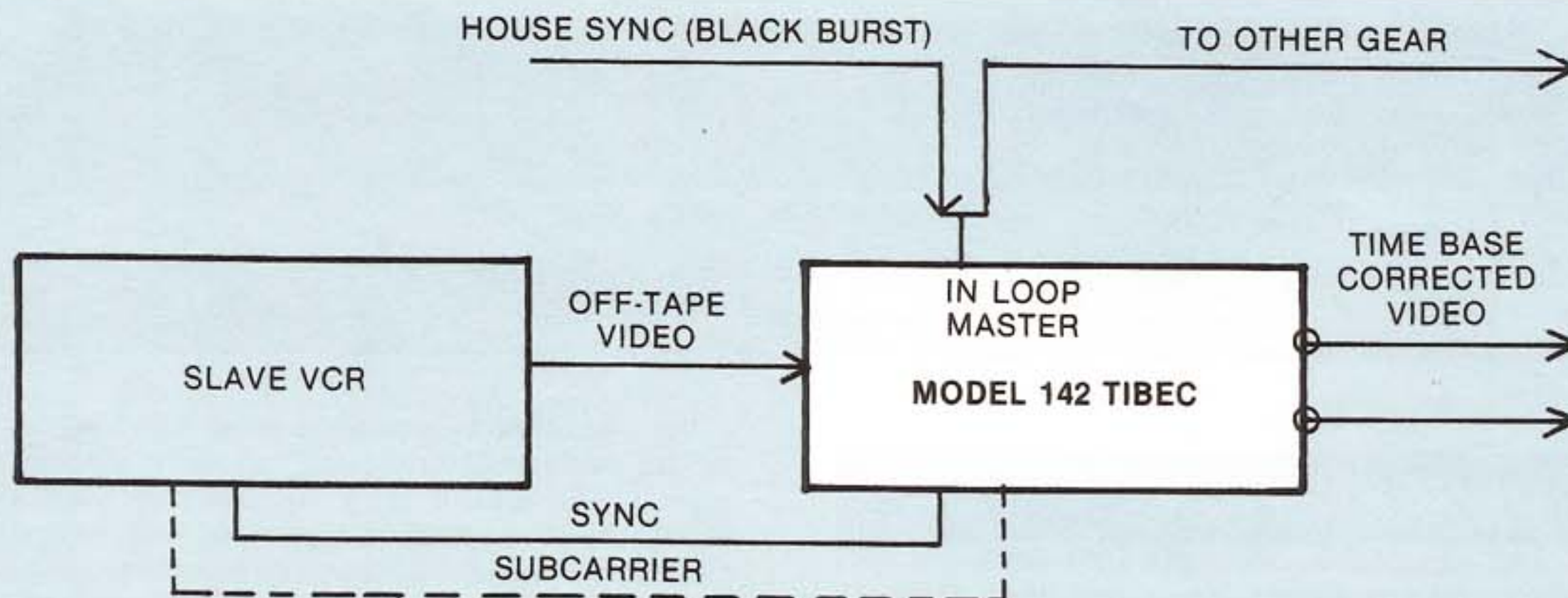

Model 142 TIBEC as TBC genlocked to House Sync.

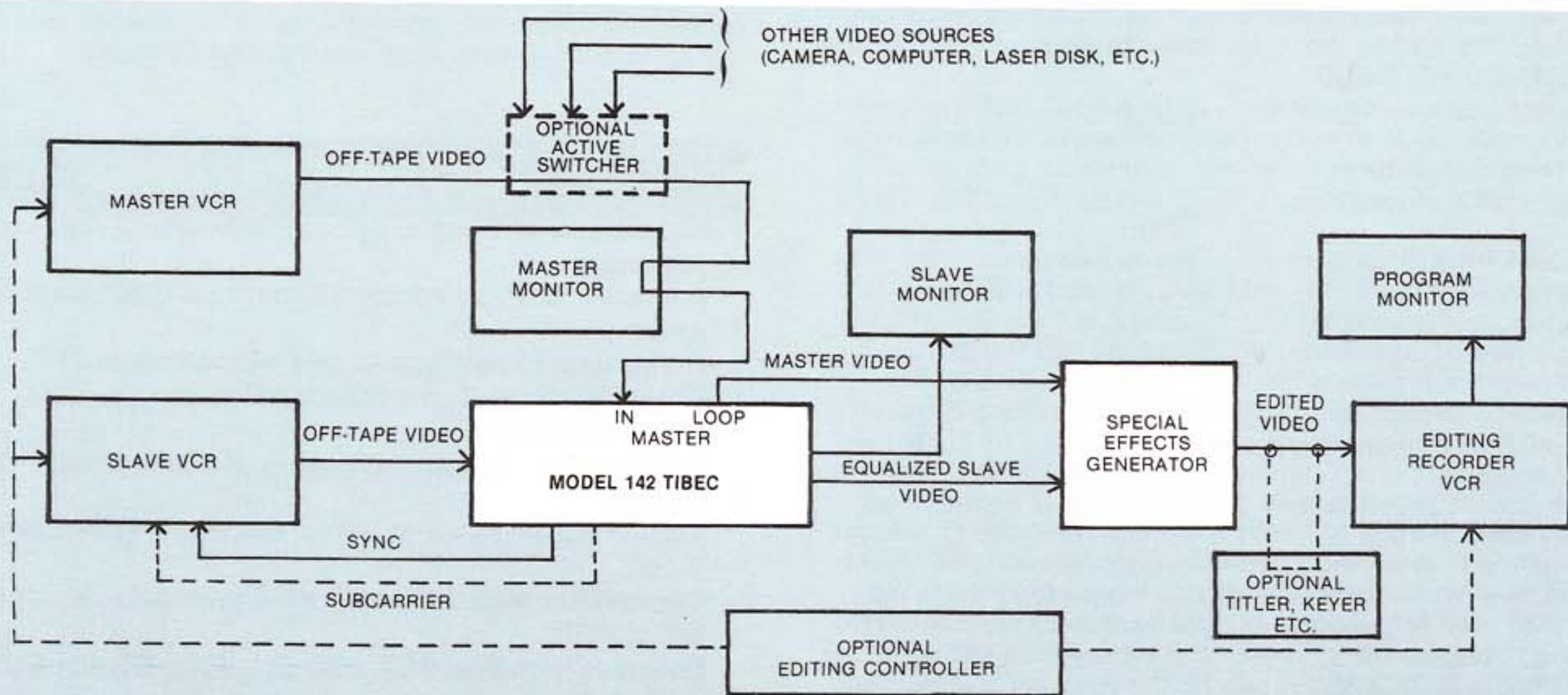

Complete Post-Production Facility, With Multi-Source A/B Roll Editing.

If you wish to know more about Time Base Errors, call **SciTech** and ask for our free paper "Time Base Errors, Correctors & Equalizers... A Look At The Basics," or our Demo Tape in any format.

SciTech
CORPORATION

1450 N.W. 78 Ave.,
Miami, FL 33126
(305) 591-1620

**Bringing Real Innovation
Directly to You**

ORDERS ONLY CALL:
1-800-421-4407 (West Coast Office)
1-800-842-0070 (East Coast Office)

DISTRIBUTED BY:

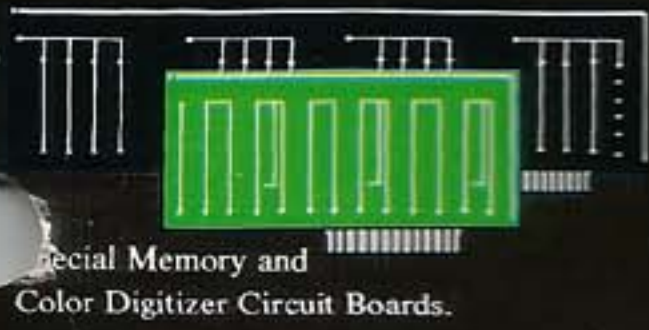

Special Memory and Color Digitizer Circuit Boards.

Biflyx Special Image Processor, Monitor, Keyboard



High Resolution Color Video Camera

High Resolution Color RGB Monitor and Video Cassette Recorder



Biflyx Color Video Portrait System

311 North Clara Street
Santa Ana, CA 92703 • (714) 953-5666

THE ALL NEW STATE OF THE ART SYSTEM THAT PUTS YOUR COLOR PORTRAIT ON

- T-Shirts
- Greeting Cards
- Special Occasion Formats
- Awards
- Souvenirs and more

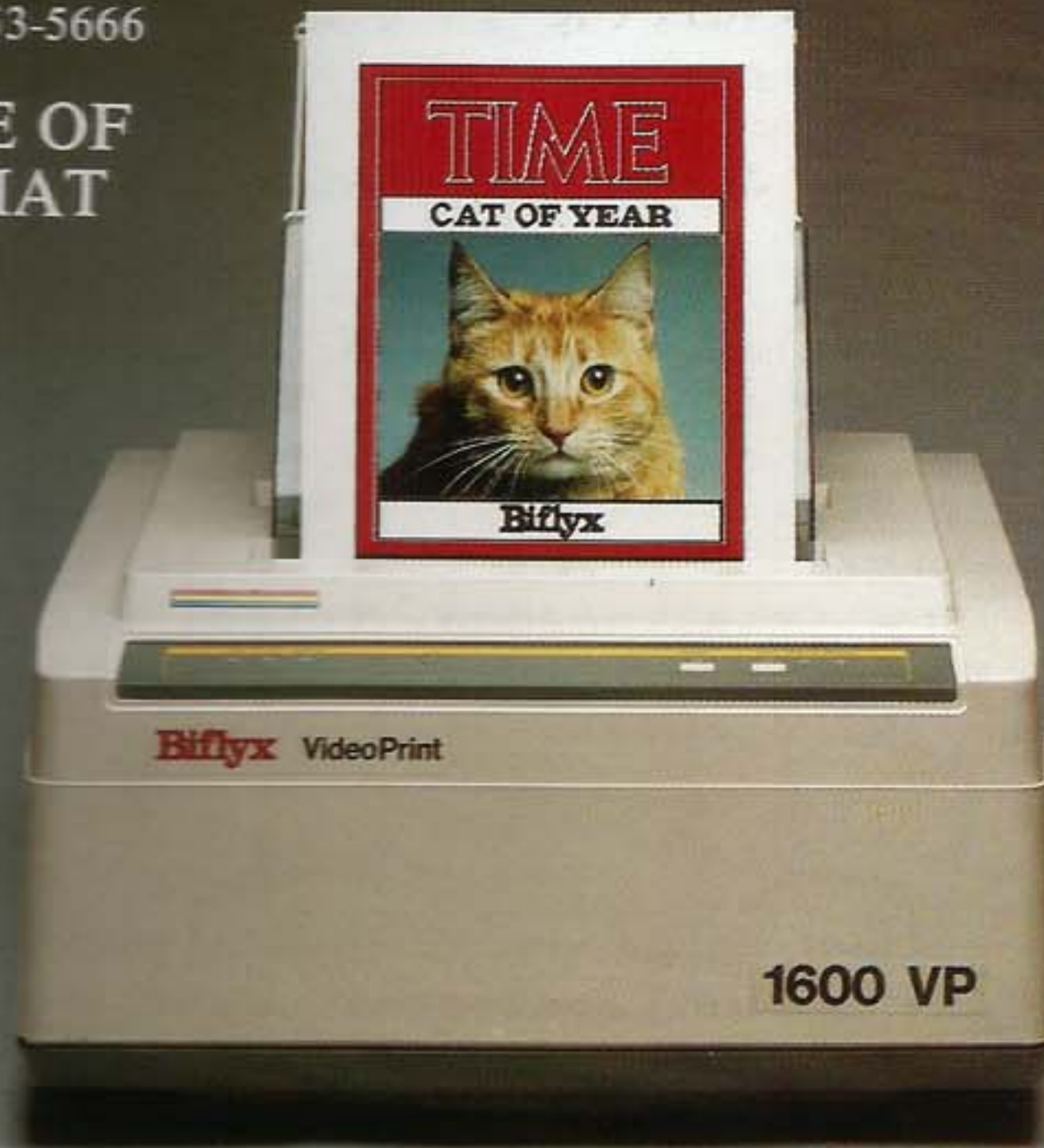

BIFLYX COLOR VIDEO PORTRAIT SYSTEM

The Biflyx Foto-Video Portrait System allows the full color transfer of any video image to either paper or cloth.

The printed image can be made from any video signal (camera, tape, live TV.) The subject can be in person, snapshot or video taped. The image is placed on the Color Monitor, frozen and transferred to the printer, resulting in a high resolution, full color video print. There are no chemicals or toners used in the printer. The Foto-Wear electronic image transfer to cloth is a proprietary Biflyx process. The process allows for the complete transfer of the image, resulting in a cloth picture that is comparable to the paper version.

We currently offer three different systems, which are:

SYSTEM_501 - This system consists of a 501 processor, 1600VP printer, and your choice of any two of the existing formats we currently have in inventory. With the addition of a video camera and a video monitor, this system will enable the user to snap instant video portraits and print them on either paper or transfer to cloth (T-shirts, aprons, totes, etc.). The elapsed time for printing the portrait or transfer with this system is approximately three (3) minutes.

Price \$ 12,995.00

SYSTEM_601 - This system consists of a 601 processor, 1600VP printer, and a selection of ten formats from our inventory. With the addition of the appropriate peripheral components the user can now offer the customer a variety of formats to choose from, and print the product in a little over two (2) minutes. The 601 will work well for the operator who needs faster operations and greater format variety.

Price \$ 15,995.00

SYSTEM_701 - This system consists of the 701 processor and the 1600 VP printer. The 701 processor is a hard disk drive unit with all the capabilities of the 601 and has the additional capability to store for immediate recall up to 100 formats (30 furnished with system) and has 100 addresses for memory storage. This allows you to snap the subject and place the image in memory for processing at a later time. The 701 will also allow you to snap and print simultaneously, processing the previous subject while you pose and snap the next. This system offers the operator the maximum in speed and versatility.

Price \$ 19,995.00

Photo-Me 
AUTO PORTRAIT

**A UNIQUE
COMMERCIAL OPPORTUNITY
FOR PHOTOGRAPHERS**

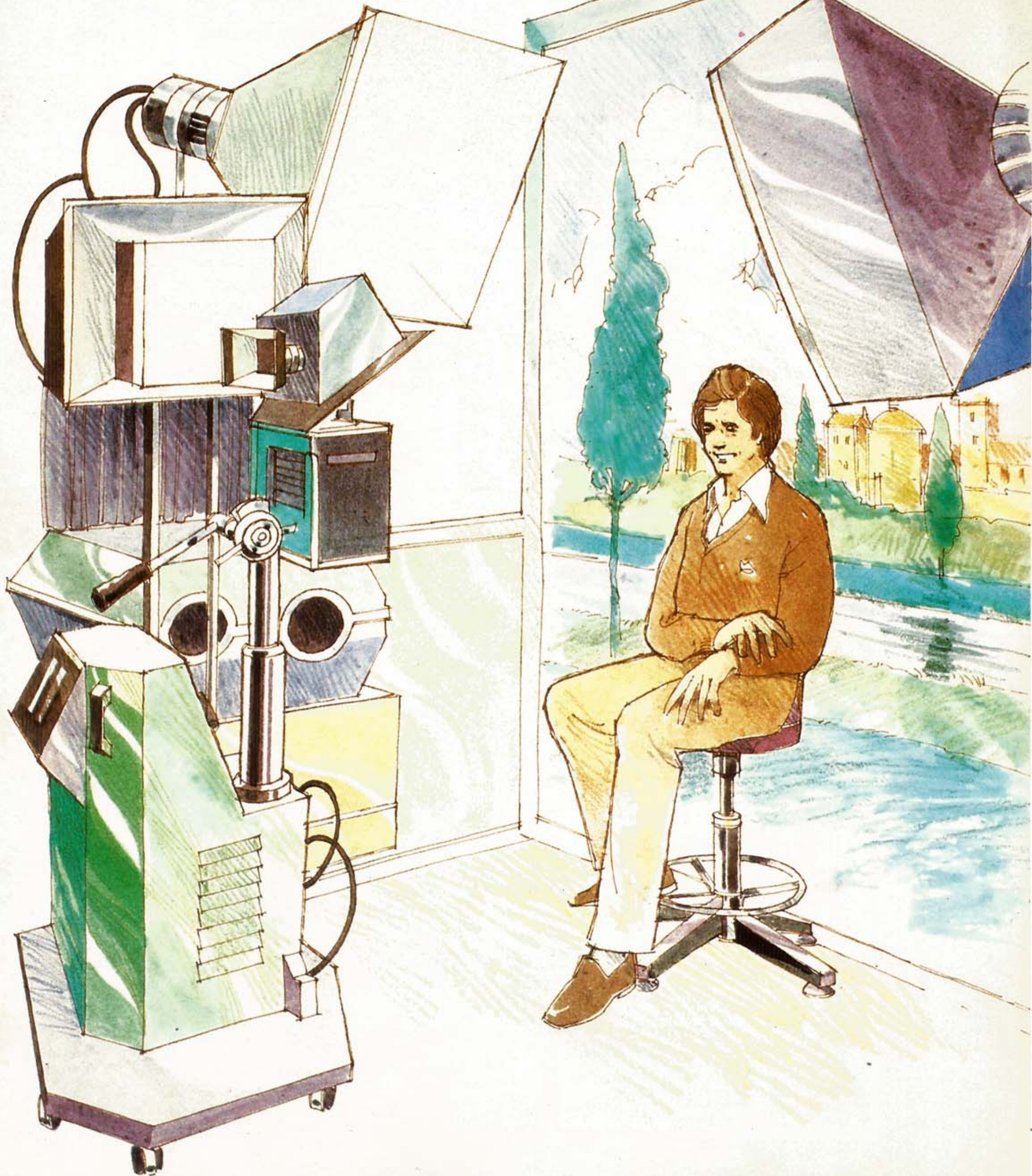



MARKETING

A new concept in portrait photography

With over 40 years' experience in the world of instant photography, Photo-Me International PLC is now offering photographers a unique opportunity to increase the turnover and profitability of their studios through their Autoportrait System.

A portrait processed in 5 minutes

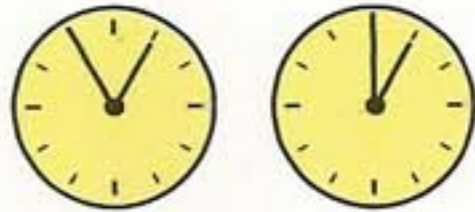

Due to the simplicity of the Photo-Me Autoportrait System a photographer is able to pose and fully process an 8in x 10in portrait in under 10 minutes. This time factor is short enough for the customer to wait, but long enough to increase the possibility of impulse purchase whilst he is waiting.

With any background you choose.

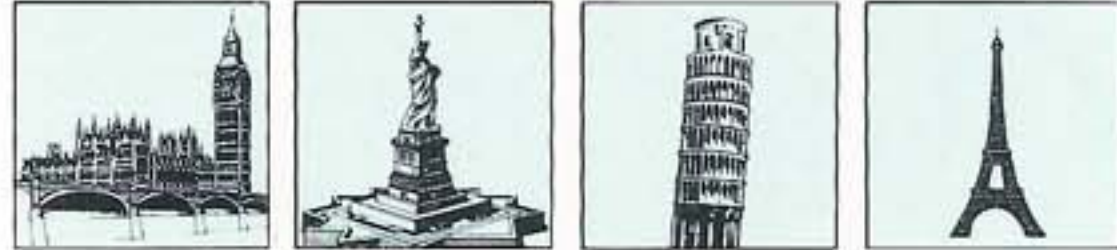

The front projection system offers the photographer an opportunity to pose his subjects in front of an infinite variety of backgrounds making the service more marketable and increasing the sales potential.

Costing less than a small roll of film

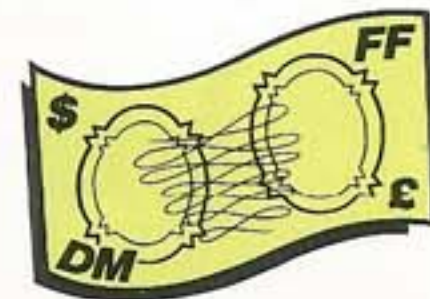

By holding down the purchase price of the equipment and ensuring that the paper and chemicals are kept highly competitive, the consumable cost to the photographer is less than he would normally pay for a small roll of film.

Thus Photo-Me International PLC offers Autoportrait users higher profits through low costs, high margins, and increased demand.

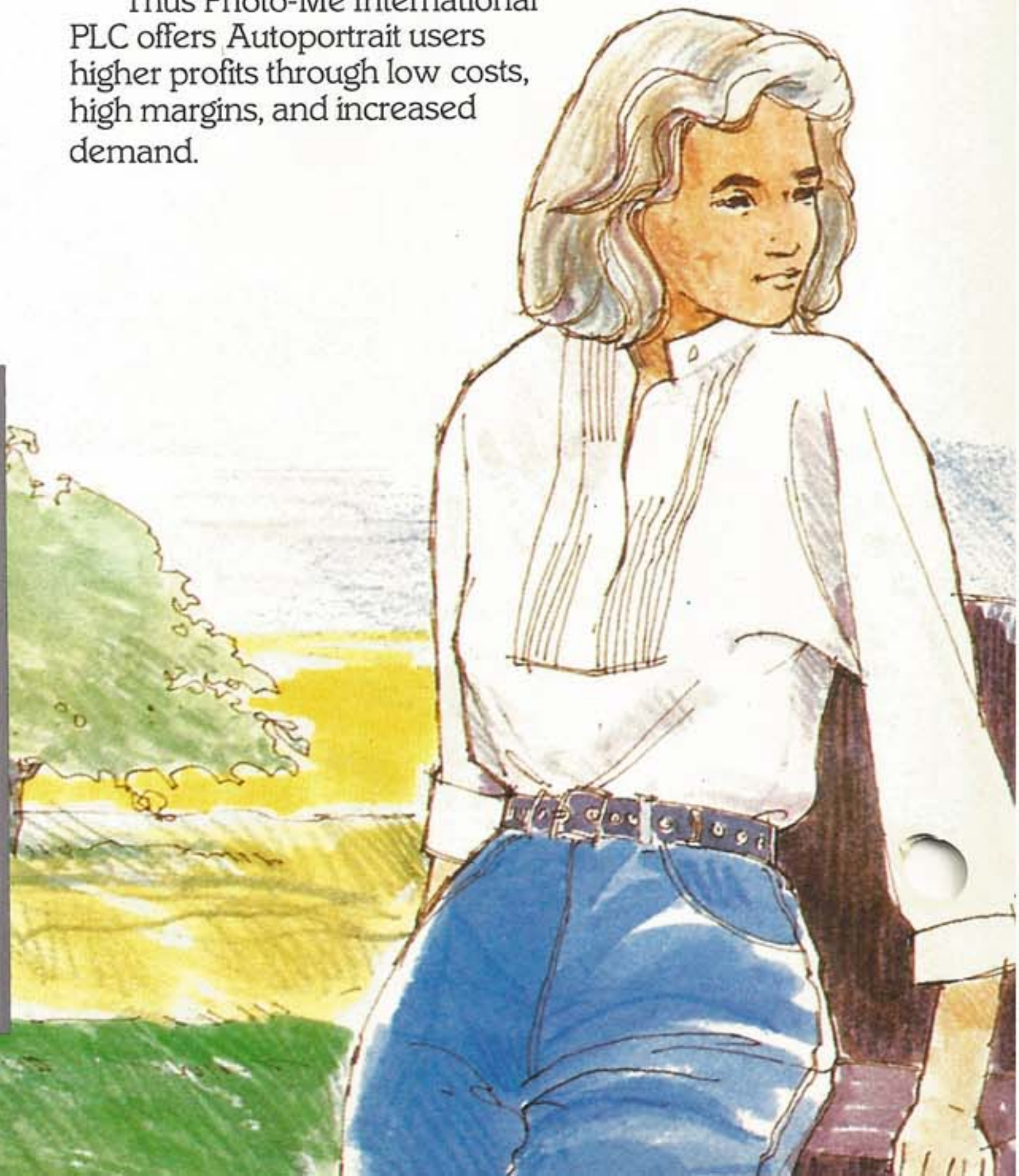
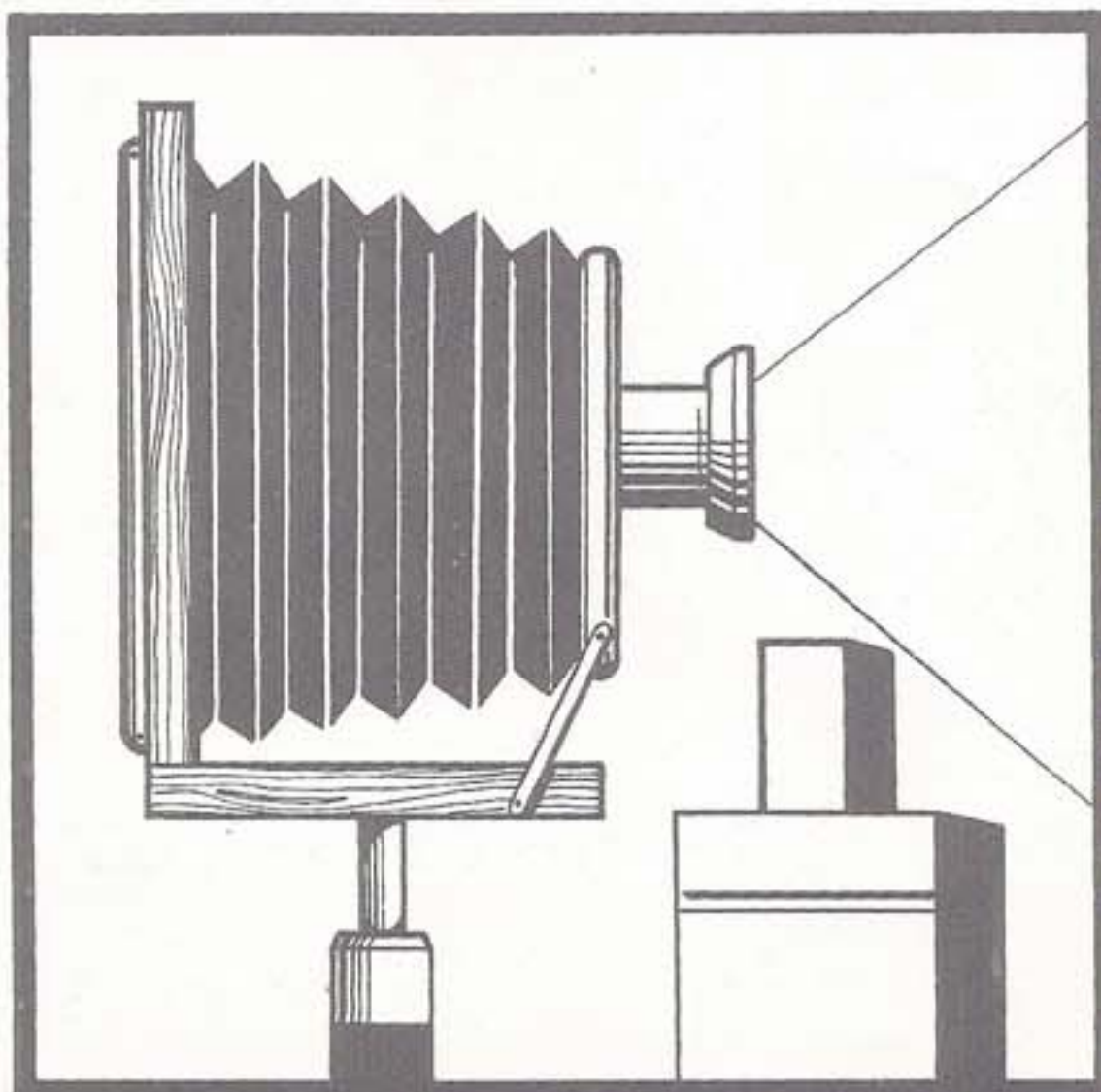



COMPONENTS

The Autoportrait System comprises a camera, lighting equipment, automatic processor and drier, front projector and background screen. The system is a small professional photographic studio enabling a photographer to take high quality professional 8in x 10in portraits and deliver them to the customer while he waits, at an extremely competitive price.

A specially developed front projector allows the customer to be posed in front of any background he chooses either by using one of the 2 1/4in x 2 1/4in slides supplied or using one of his own transparencies.

The unique large format camera incorporates a 300mm* lens and an integral mirror enables the subject to be exposed directly onto a sheet of Photomechrome reversal paper. The camera can also be used for advertising and copy applications. The camera and front projector are mounted on a motor driven tripod assembly which also houses the strobe generator and lighting controls.

A four-bath table-top processor and drier incorporating variable speed and temperature controls gives an average processing time of five minutes per print with a capacity of up to 60 prints per hour.

The key to the system is in the paper which produces high definition photographs with maximum stability. Accelerated exposure tests have indicated a maintenance of basic colours for up to 15 years without

any fading taking place. The paper can also be used for laminating without any risk of defacing. Photomechrome 595 higher speed material is supplied in matt or gloss, with a paper or polyester base.

Each chemical kit will process up to 350 prints and consists of three separate components which are easily made up to working solutions by mixing with water.

Exhaustive research and development has resulted in a system of robust quality and inherent reliability. Photo-Me International PLC has an extensive domestic and world-wide service network which assures the Autoportrait user of prompt product support.

Autopassport – An optional extra

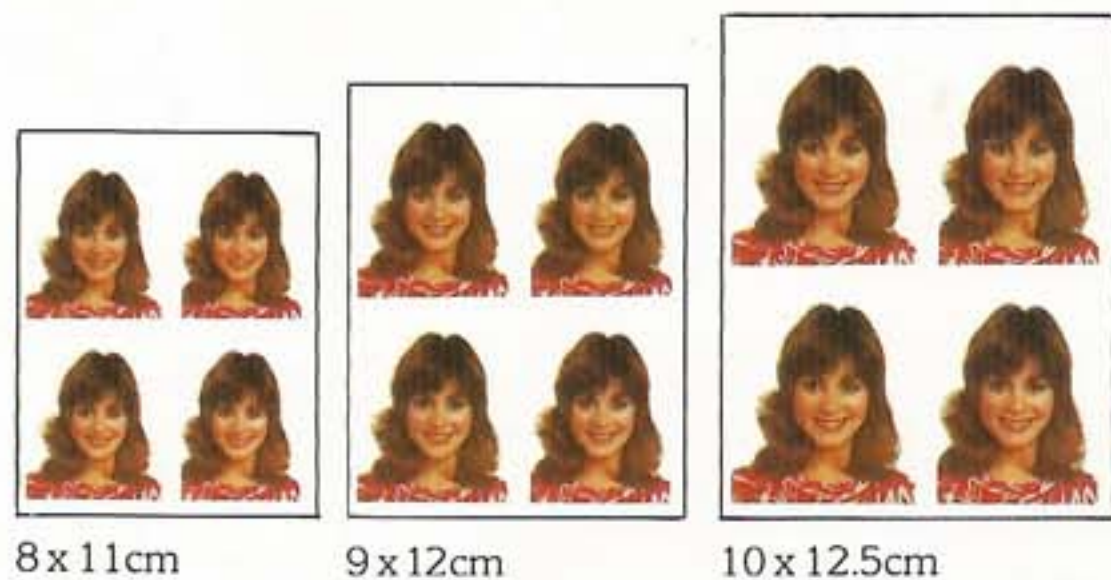

As the world's largest manufacturers of coin-operated photographic equipment, Photo-Me International PLC also recognise the fact that there are many instances where a more personal service is desirable.

The Autopassport camera has been developed to fulfil this need and is available in three different sizes to suit local identification requirements, and provides the photographer with a facility to offer his customers a complete range of I.D. photographs.

The equipment has been designed to be totally compatible with the Autoportrait System requiring no additional lighting or processing facilities.



*A 240mm lens is also available as an option.



SYSTEM COSTS

Because conventional portrait systems are time consuming and incur high material and operating costs, the selling price of the finished photograph has traditionally been prohibitively expensive causing an artificial resistance amongst the general public to this type of photographic service. The Photo-Me Autoportrait System overcomes this by allowing the photographer to offer the most

competitively priced portrait service available today. Due to the instant nature of the system the financial transaction with the customer is completed at the same time as the portrait is taken, thereby greatly assisting the photographer's cashflow.

The graph below shows a break-even chart based on typical U.K. figures.

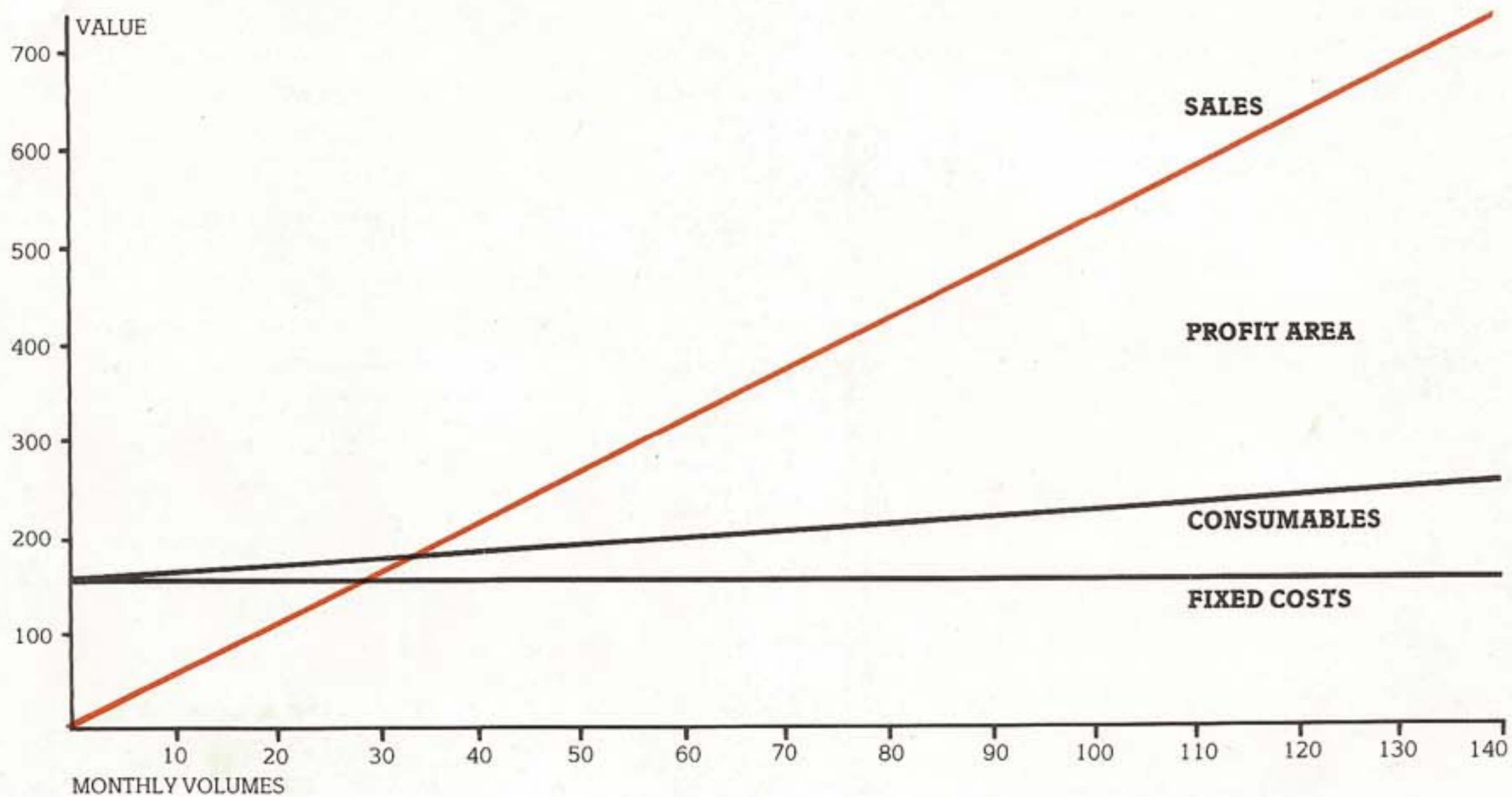

Authorised dealer:

Photo-Me
INTERNATIONAL PLC



Photo-Me International PLC,
Autoportrait Marketing,
Station Avenue, Walton-on-Thames,
Surrey KT12 1SB.

TELEPHONE: (0932) 220461
TELEX: 928898

**WE'VE GOT
THE INSIDE TRACK
ON AMERICA'S
NEWEST HIT!**



**YOU HAVEN'T
HEARD THE BEST
OF OUR PITCH.**

If you want the hottest new musical concept in the nation today, choose one of our many sales options, such as a total purchase plan, or a concession agreement. Financing or lease-to-purchase is also available.



For franchise information write or call:

STAR TRAX, INC.

Super Star Recording Studios

P.O. Box 110

Myrtle Beach, South Carolina 29578

(803) 650-1958

**EVERYONE'S
SINGING
OUR SONG!**

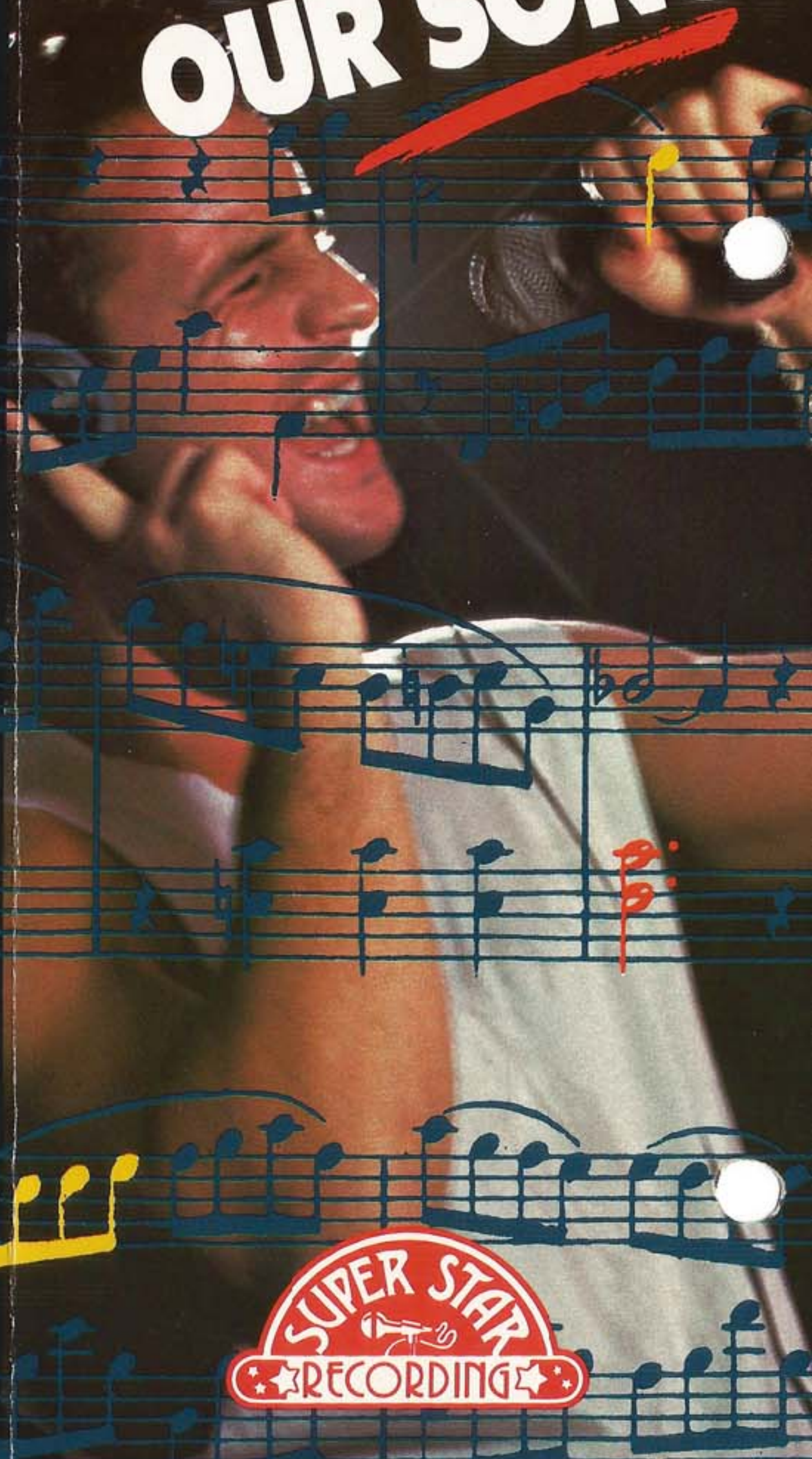

The Super Star Recording Studio is the hottest new concept in the amusement industry. An inexpensive and entertaining recording studio, Super Star allows anyone to record a high-quality cassette of their own voice singing today's hot new music.



1. Participants select their favorite song from the largest collection of recorded hits from every musical category.

2. They enter a totally private recording booth with the words to their selected hit song and practice as they hear the music... as simple as singing along with the radio.

3. As they sing into the microphone, they'll experience the excitement of recording just like the stars!

4. They'll take home one of the hottest souvenirs in the world! And, they'll be back for more!

RECORDING



A SOLO PERFORMANCE DESTINED FOR STARDOM.



Proven successful in major tourists attractions around the country, Super Star Recording Studios have consistently produced outstanding gross income and net profits.



Super Star manufactures the only equipment made exclusively for this concept. It is designed to be both easy to operate (to cut labor costs), and durable enough to withstand many years of commercial use. It is backed by a 3-year, full guarantee.

Super Star provides everything needed to open and operate a recording studio. Pre-recorded sound tracks (the largest selection available), cassettes, equipment, installation, training of personnel, and service are included in the price of the studio. The studios may be installed in a permanent location or made portable, using our modular building units of self-contained trailers.

**AS
FEATURED
ON NBC
NIGHTLY
NEWS**



"EVERYONE'S SINGING OUR SONG!"

STAR TRAX welcomes the opportunity to show you why we have been the "starring" attraction around the U.S. and Canada since 1984. Due to the overwhelming excitement and response, there are now 25 SUPER STAR Recording Studio locations. STAR TRAX has given the opportunity for "shower" performers to experience becoming a "star"...for just a moment!

Having recorded over 250,000 SUPER STARS this year in our studios, it is easy to become enthusiastic about a SUPER STAR studio. With the high profit margin and low personnel cost, our locations have proven to be successful in malls, amusement parks, and other tourist attractions.

Music is the pulse of the SUPER STAR Recording and Video Studios. The precise orchestration of our sound-a-like soundtracks make them hard to distinguish from the original hit songs. Of course, STAR TRAX is fully licensed from the writers and publishers to produce the sound-a-likes and pays royalties for their use. Keeping current with the biggest hits climbing the charts, we produce an average of 10 songs per month. The SUPER STAR songlist is divided into twelve musical categories for easy selection and appeal to every age group. You can always find your favorite song at a SUPER STAR Recording Studio!

We are proud of the STAR TRAX name and the holsum family atmosphere found at a SUPER STAR studio. Our expertise in the mini-recording studio market keeps us #1 on the charts. It's no wonder why "EVERYONE IS SINGING OUR SONG!"

The logo for STAR TRAX is displayed in a stylized, outlined font. The word "STAR" is positioned above "TRAX", and both are connected by a horizontal line that extends to the left and right edges of the page's border.

"A MUSICAL PERFORMANCE DESTINED FOR STARDOM!"

WHAT A NATURAL! Record your favorite song at a SUPER STAR Recording Studio then "star" in your own M-TV type music video at a SUPER STAR Video Studio! The combination of recording and video has become the newest hit attraction across the nation. Music videos are not new in the mini-studio market, but STAR TRAX has taken them a step farther...CHROME-A-KEY music videos!

Making a music video is even more fun than recording! Once you have your song recorded, choose a background subject for your music video to match the theme of your song. Next, lip-sync the lyrics while adding your own choreography to the camera. The camera operator will transform you into the background making you the star of your own music video! Imagine yourself...

SINGING "BORN IN THE USA" WITH A WAVING FLAG...

SINGING "YANKEE ROSE" IN THE BRIGHT LIGHTS, CITY LIGHTS...

SINGING "OVER THE RAINBOW" AMONG FLOATING CLOUDS...

The combinations are endless but as close as your imagination! Of course, we add the right props to your set. Guitars, drums, keyboard, and tambourines along with hats, sun-glasses, wigs, and other accessories complete your starring role in the SUPER STAR video!

The STAR TRAX video system uses only broadcast quality equipment. Of course, we could have chosen a less expensive method of producing music videos, but our market has learned to expect only the highest in technology in a SUPER STAR studio! CHROME-A-KEY is certainly no exception; It is best described by the example from the movie, SUPERMAN. He appeared to be flying over tall buildings when actually thru the technology of signal processing, SUPERMAN was superimposed into a pre-recorded moving background. This is the same process used in making a SUPER STAR video!

STAR TRAX has done it again...first SUPER STAR Recording Studios and now, SUPER STAR Video Studios. Entire families are "starring" in SUPER STAR videos, watching them time and time again at home. Watch yourself in "A MUSICAL PERFORMANCE, DESTINED FOR STARDOM!"

STAR TRAX

"WE'VE GOT THE INSIDE TRACK ON AMERICA'S NEWEST HIT!"

EXCLUSIVITY! The STAR TRAX line of recording equipment is the ONLY recording equipment made solely for the mini-recording studio. The format and design has been applauded by the industry. After 2½ years of operation in our SUPER STAR Recording Studios, the STAR TRAX equipment has operated with ease and efficiency.

STAR TRAX opened the first SUPER STAR studio with the same equipment the competition uses...the kind bought off the shelf of any audio store! Quickly, we knew the equipment was not built to operate under heavy usage, 10-12 hours per day, so immediately research began on the equipment needs of a mini-recording studio. Upon contracting with an audio architectural firm, a state-of-the-art mixing console was designed and assembled in our manufacturing plant...the results were superior!

Rugged, compact, and dependable, the STAR TRAX mini-recording mixing console is modular to fit the needs of any studio size. One engineer can operate 1,2,3, or 4 recording booths at once by simply interfacing the modular units together. This is another exclusive idea from STAR TRAX!

Today, STAR TRAX is in the third stage of equipment manufacturing. Each stage reflects advancements made to keep up with the growth of the mini-recording studio concept. With the STAR TRAX line of recording equipment, SUPER STAR Recording Studios have "THE INSIDE TRACK ON AMERICA'S NEWEST HIT!"

**STAR
TRAX**

"YOU HAVEN'T HEARD THE BEST OF OUR PITCH!"

A TURN KEY OPERATION! That's exactly what STAR TRAX offers you to fit any location planned for a SUPER STAR RECORDING AND VIDEO STUDIO... Built permanent, modular, portable or mobile, the SUPER STAR studio "stars" above the rest!

PERMANENT STUDIO - By assisting you in planning the size, lay-out, and design, STAR TRAX will dazzle any location with a permanent SUPER STAR studio!

MODULAR STUDIO - When permanent construction in an existing building is not permitted, a modular studio is possible. STAR TRAX will build the entire studio in our plant to your size and lay-out, then we will set it up inside of your space!

PORTABLE STUDIO - Planning to take your studio to a party or convention? STAR TRAX will provide a complete studio in a portable way! With equipment in road-cases and a portable recording booth, this studio is made to set-up in less than one hour!

MOBILE STUDIO - STAR TRAX has designed a studio to "take on the road!" The mobile recording studio has 3,4, or 6 recording booths and an engineer's control room. Pull it with a truck, park at your amusement location, then plug it into an electrical outlet...simple and quick...you are OPEN for business!

STAR TRAX

SUPER STAR RECORDING STUDIO EQUIPMENT LIST

- ***TOTAL MIXING/RECORDING SYSTEM. 1 PER BOOTH
 Including features such as, playing the master soundtracks, records final tape, mixes live vocals into music, equalization controls for live vocals, independent sub-mix controls, built-in compressor-limiter, built-in total communications network for engineer-to-booth contact and many more features that make the system simple to operate!
- ***150 PRE-RECORDED SOUNDTRACKS.
 Our sound-a-like music tracks are exclusively produced by STAR TRAX using some of the nation's finest studio musicians!
- ***TRAINING OF YOUR PERSONNEL.
 A comprehensive training program on operation and maintenance.
- ***ALL EXPOSED CABLE AND CONNECTORS USED IN INSTALLATION.
- ***SHURE SM-48 VOCAL UNIDIRECTIONAL MICROPHONE. 1 PER BOOTH
- ***MICROPHONE STAND AND BOOM ARM. 1 PER BOOTH
- ***DUPLICATOR. 2 UNITS PER STUDIO
- ***STEREO PRE-AMPLIFIER AND POWER AMPLIFIER. 1 UNIT PER STUDIO
- ***HEADPHONES. 4 PER BOOTH
- ***PLAYBACK UNITS. 1 PER 2 BOOTHS
- ***ALL WIRING IS MILITARY-GRADE FOR YEARS OF DEPENDABLE SERVICE.
- ***MONITOR SPEAKERS. 2 SPEAKERS
- ***MASTER TAPE HOLDERS.
- ***RECORDING LIGHTS. 1 PER BOOTH
- ***ELECTRONIC TYPEWRITER.
- ***SONG BINS. 6 PER STUDIO
- ***LYRIC SHEETS. 100 PER SONG
- ***TALLY SHEETS. 100 SHEETS
 Used for logging the number of songs recorded for royalty payments.
- ***SUPER STAR CASSETTE INSERTS. 1000 INSERTS
- ***SUPER STAR RECORDING CASSETTE LABELS. 1000 LABELS
- ***CASSETTE TAPES AND CASSETTE BOXES. 500 PER STUDIO
 BASF C-10 Chrome II Plus tapes with Norelco boxes for the highest quality recording.

**STAR
TRAX**

SUPER STAR VIDEO STUDIO EQUIPMENT LIST

*** <u>THREE TUBE COLOR CAMERA.</u> Features CCU, zoom control, focus control, and cable.	<u>1 PER STUDIO</u>
*** <u>CAMERA TRIPOD.</u>	<u>1 PER STUDIO</u>
*** <u>SWITCHER.</u>	<u>1 PER STUDIO</u>
*** <u>CHROM-A-KEYER.</u>	<u>1 PER STUDIO</u>
*** <u>RACK CASE.</u>	<u>1 PER STUDIO</u>
*** <u>TIME BASE CORRECTOR.</u>	<u>1 PER STUDIO</u>
*** <u>3/4" VIDEO CASSETTE PLAYER.</u>	<u>1 PER STUDIO</u>
*** <u>RACK MOUNT COLOR MONITORS.</u>	<u>4 PER STUDIO</u>
*** <u>CYC LIGHTS.</u> 1000 watts each light.	<u>3 PER STUDIO</u>
*** <u>SOFT LIGHTS</u> 2000 watts each light.	<u>3 PER STUDIO</u>
*** <u>HOOK UP CABLES.</u>	<u>1 LOT</u>
*** <u>1/2" FOUR HEAD VIDEO CASSETTE HQ, HI-FI STEREO RECORDERS.</u>	<u>3 PER STUDIO</u>
*** <u>19" TV MONITORS.</u>	<u>4 PER STUDIO</u>
*** <u>MUSICAL INSTRUMENT PROPS.</u> 2 Electric Guitars, 1 Bass Guitar, 1 Acoustic Guitar, 1 Keyboard, 1 Drum Set, 2 Tamborines.	<u>1 LOT</u>
*** <u>COSTUME PROPS.</u>	<u>1 LOT</u>
*** <u>3/4" MASTER BACKGROUND TAPES.</u>	<u>30 PER STUDIO</u>
*** <u>150 MUSICAL SOUNDTRACKS.</u> Choose 150 soundtracks from our wide selection of hit sound- a-likes.	
*** <u>SUPER STAR VIDEO CASSETTE LABELS.</u>	<u>1000 PER STUDIO</u>
*** <u>1/2" CASSETTE VIDEO TAPES WITH BOXES.</u>	<u>100 PER STUDIO</u>
*** <u>CASSETTE PLAYER FOR AUDIO SOUNDTRACKS.</u>	<u>1 PER STUDIO</u>
*** <u>PRE-AMPLIFIER AND POWER AMPLIFIER.</u>	<u>1 SET PER STUDIO</u>
*** <u>MONITOR SPEAKERS.</u>	<u>1 PAIR PER STUDIO</u>

STAR TRAX

ANALYSIS OF NEW ATTRACTION POTENTIAL

Surprises

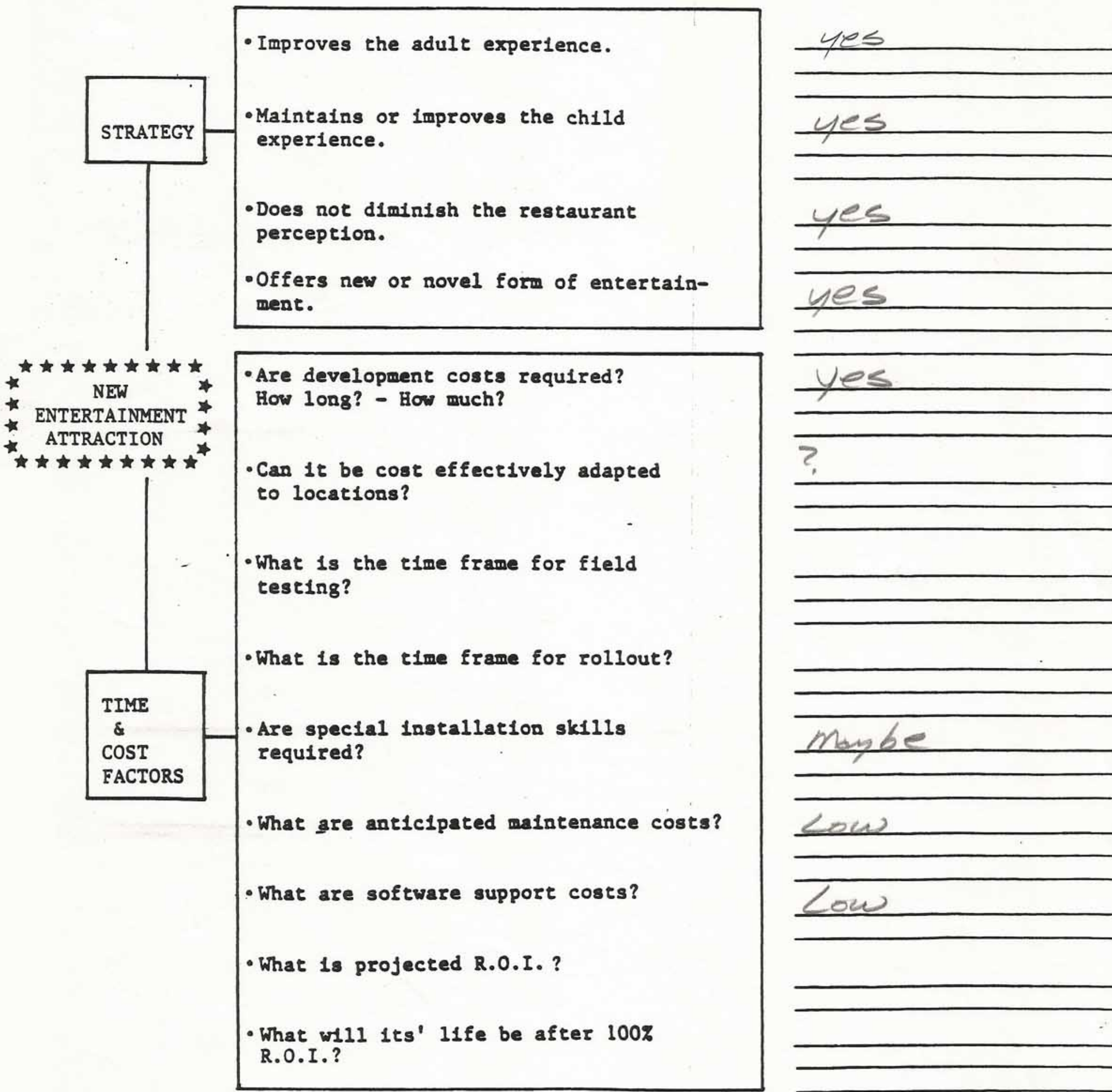

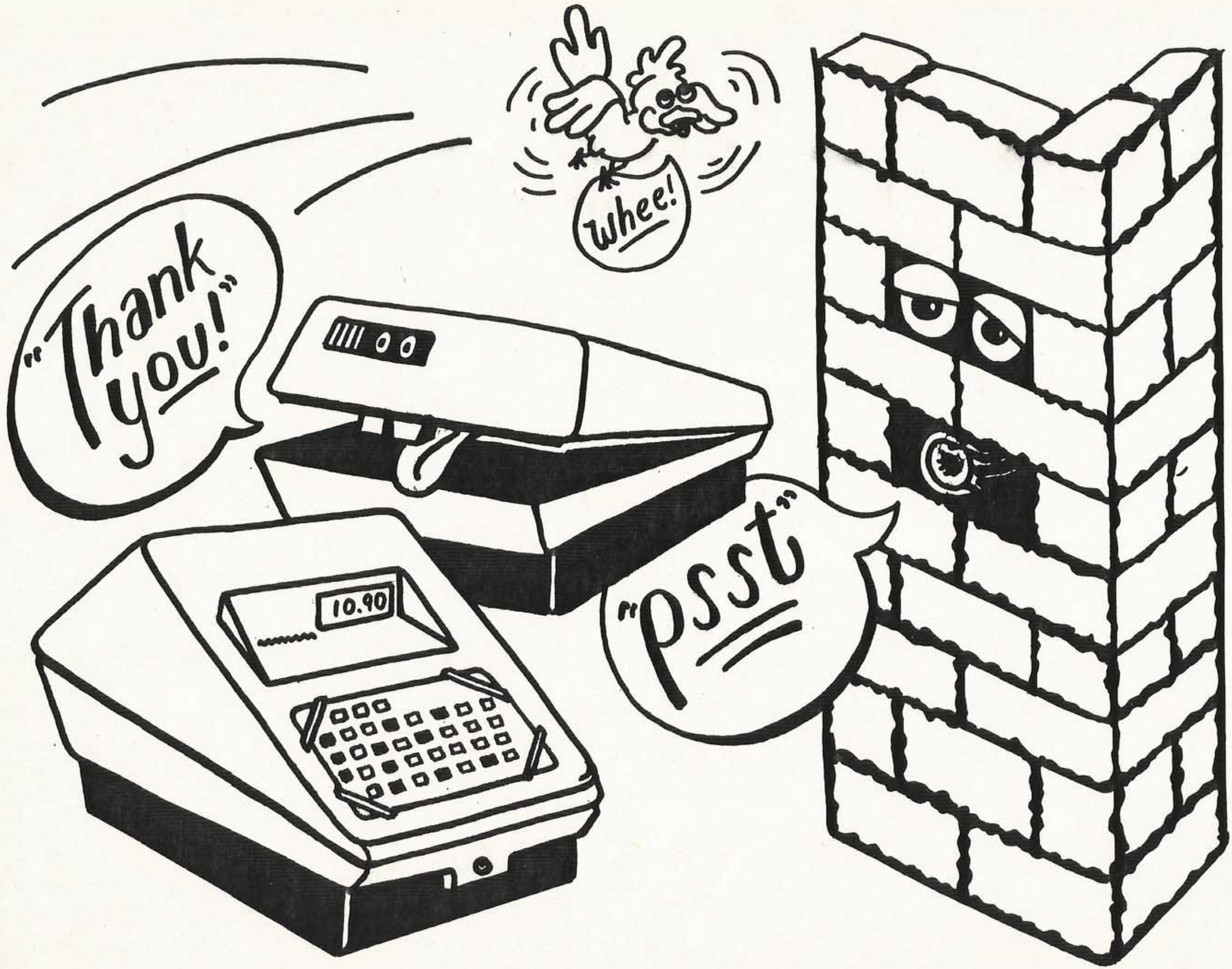

Kinetic Butterflies

● A NEW ERA IN DISPLAY ANIMATION

Captivate your customers with our exclusive lifelike moving butterflies. Available in a variety of eye-catching wing styles, patterns and designs, Kinetic Butterflies move continuously seven times per minute, 10,000 times a day.

Our butterflies are seen in Bonwit Teller's Christmas display, Fifth Avenue store; Neiman Marcus' San Francisco store window display; and Elizabeth Taylor's Passion Perfume promotion.

- Graceful, lifelike wing motion
- Silent motorless electronics
- Custom wings to match nearly any design
- Clip-on design for easy mounting and display

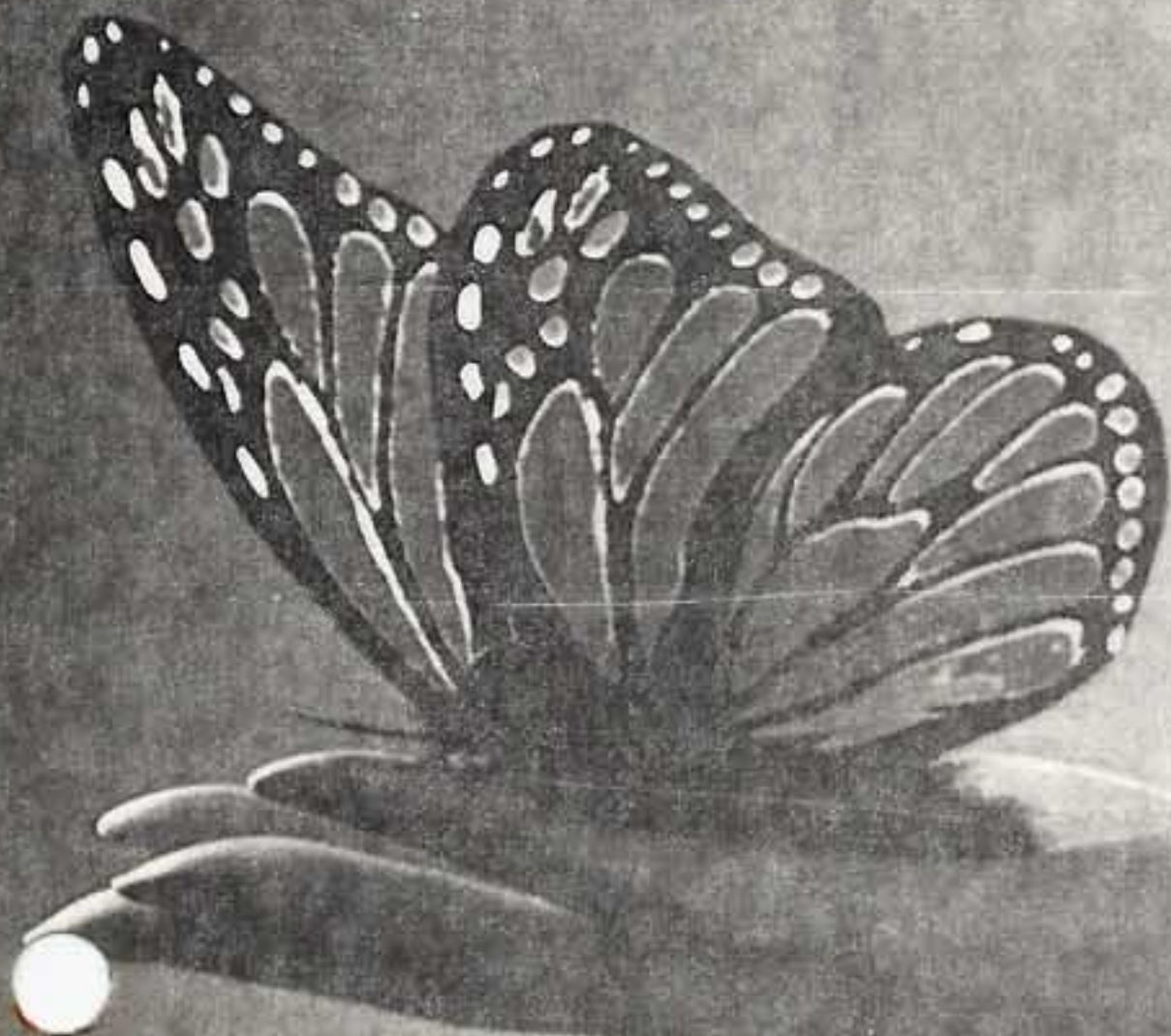
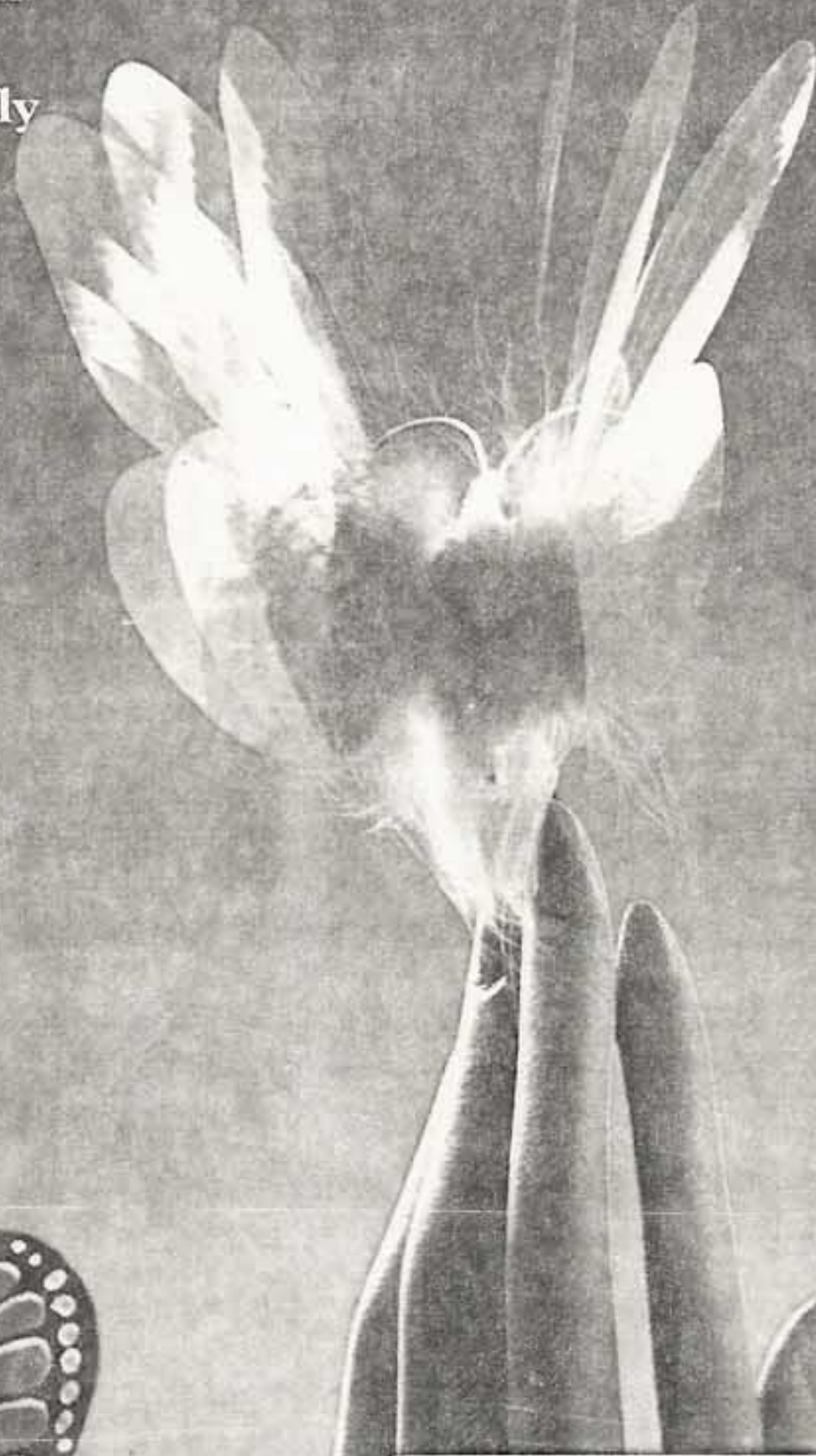

mondō-tronics
INNOVATIVE ELECTRONIC PRODUCTS

mondō-tronics
Innovative Electronic Products

20090 Rodrigues Avenue #1
Cupertino, California 95014
(408) 255-7055

Roger G. Gilbertson

TALKING FLOWERS- MECHANICAL

Each flower should follow these specification:

MOUTh MOVEMENTS (2) - Upper and lower jaw should should both be animated, although they may be actuated together as a single movement

LEAVES (3) - Each flower will have three leaves. All leaves will be tied to a single function.

FLOWER SWAY (1)- Each flower will have a sway function. When activated, the flower will sway to one side. When de-activated the flower will return to the other side.

Each flower box will have 3 inputs and a ground reference. All inputs are active low. When the inputs are not activated they will be held to a hi level of +24 VDC by our driving circuitry. The three inputs will be labeled: MOUTH, LEAVES, and SWAY. Each of the inputs will activate ALL of the corresponding functions for the flowers in that box (i.e. by pulling the MOUTH input lo, all six flower mouths will open).

When a function is activated, (input pulled lo) it will move to its activated position and stop. The function will not return to its rest position until the input is de-activated (input released to hi state). The speed at which a movement will travel between its extremes must be adjustable. The following figures are approximate ranges for each of the three movements (mouth, leaves, sway). They represent the amount of time the movement will take to travel from one extreme to the other.

	MIN	MAX
MOUTh -	.05 sec.	.5 sec.
LEAVES -	.2 sec.	2 sec.
SWAY -	1 sec.	5 sec.

These values are not absolute minimum and maximum values but the speeds we will use will be within these ranges.

The actual distance of travel for each movement will be at your discretion as the movements on the first prototype were very acceptable.

CONFIDENTIAL

Kinetic Butterflies

Available with 5 inch and 8 inch wingspans, and in a variety of styles and colors.

- Realistic monarch patterned wings
- Rainbow holographic foil wings
- Custom wings to match nearly any design

Kinetic Butterflies operate continuously when plugged into either the Single or Multiple Driver Box.

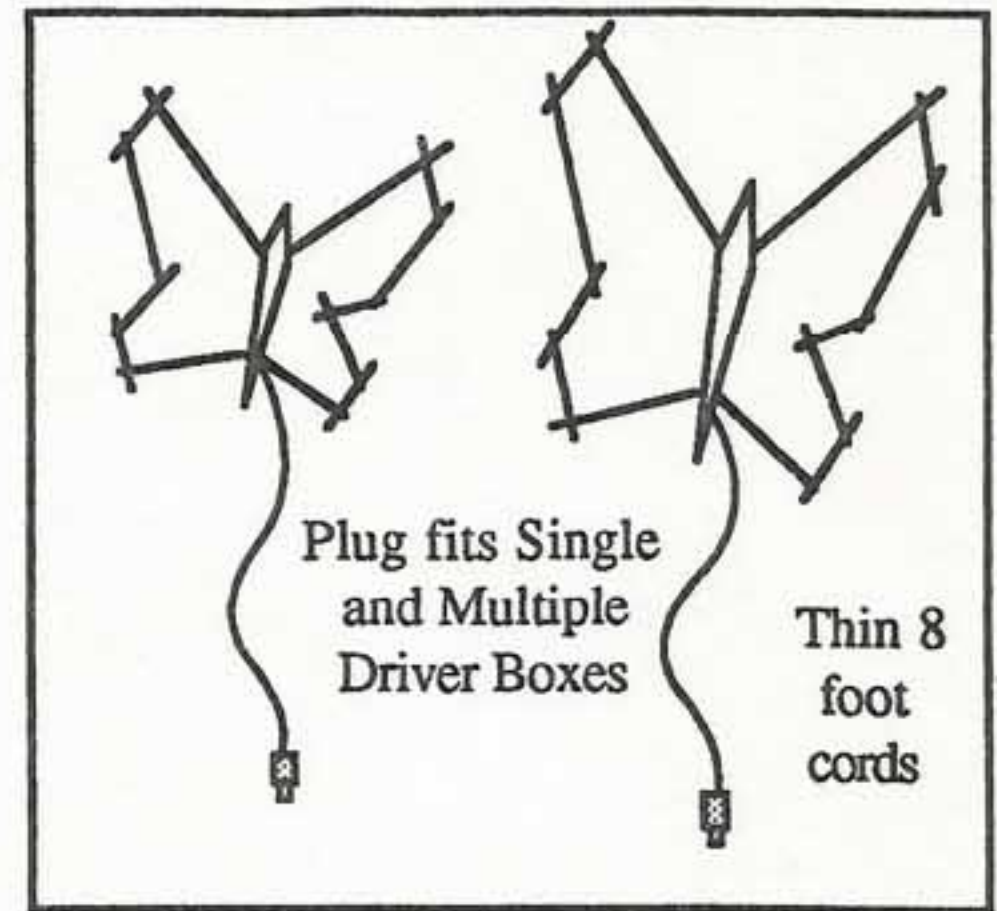

Single Driver Box

Operates one large or small Kinetic Butterfly.

Size: 1" x 2" x 3/4"
 Power: 110 Volts AC
 Color: Black

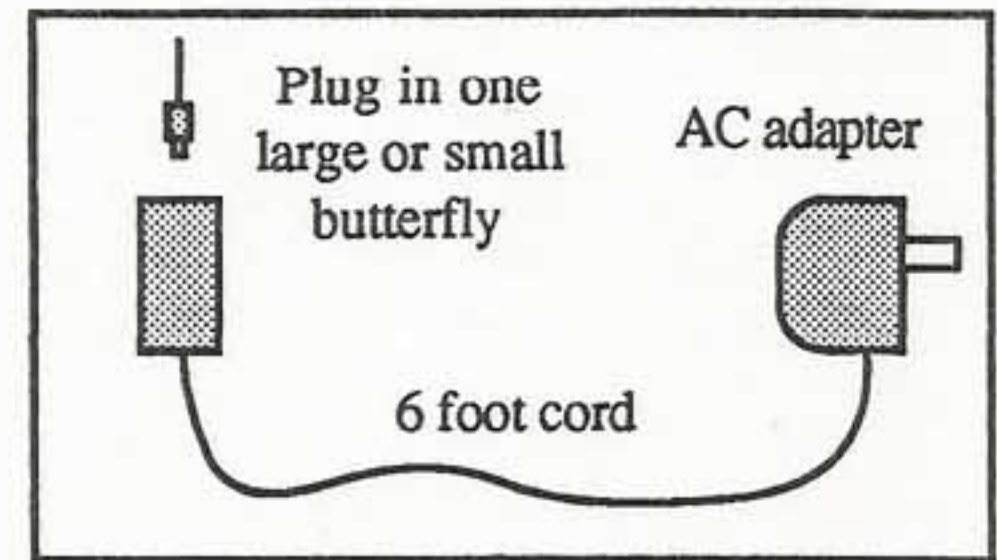

Multiple Driver Box

Operates up to twelve large or small Kinetic Butterflies, in any combination.

Size: 5" x 5" x 1-1/2"
 Power: 110 Volts AC
 Color: Black

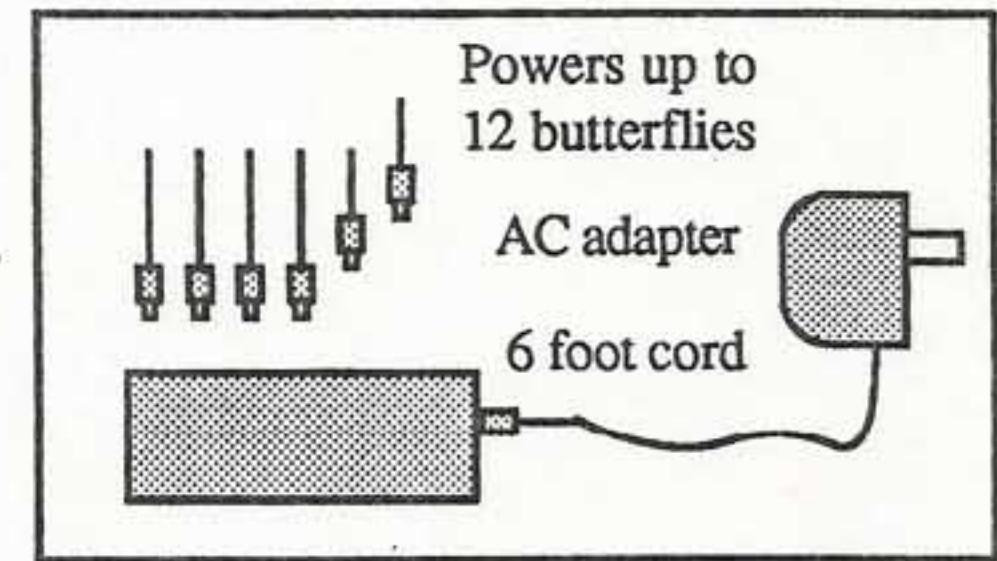

Quantity Pricing

P/N	Description	1 - 10	11 - 50	51 - 250	251 & up
3-027	Kinetic Butterfly, Standard 5" Wing	42.50	37.40	33.15	29.75
3-028	Kinetic Butterfly, Standard 8" Wing	51.00	44.80	39.00	35.10
3-029	Single Driver Box (1 output)	35.00	30.80	27.30	24.50
		<u>Each</u>	<u>2 - 5</u>	<u>6 - 25</u>	<u>26 & up</u>
3-030	Multiple Driver Box (12 outputs)	250.00	220.00	195.00	175.00

For custom wing quotations, please call us with your needs.

Specifications and prices are subject to change without notice.

DEBBY KIT
 MEMORY ELEMENT
 MAIN BLBS - ELECTRONIC
 PRODUCTS
 BIO-MEDICAL
 A SHAPE
 ITEN
 ONLY DISPLAY

TALKING FLOWERS - COSMETIC

FORMAT:

Two flower boxes consisting of 6 flowers each. The flowers should be arranged as shown in the diagram on the following page.

The Talking Flowers will be concentrated at the outer thirds of the box -- 3 on each side.

They will be graduated in heights, with the tallest being in the center of each group of three, and being approximately 12" tall.

This will create an obvious "scooped" effect in the center of the box, which is intentional and will serve to frame the animated character behind it.

The auxiliary and stationary flowers will completely cover and fill in the base around the Talking Flowers, almost in a solid mound fashion. Use lots of greens with flowers interspersed. The desired effect is to be lush and overflowing from the box.

COLOR:

The Talking Flowers themselves will be a vibrant red or red-orange color.

The two petals which fall directly behind their eyes will be airbrushed in a lighter shade, such as a cream or coral, which fades back on out into the red around the edges of the petals, the intent being to accentuate the eyes.

The stationary flowers should be a mixture of yellow and white daisies, black-eyed susans, and either a few cornflowers, bluebonnets, or tiny wild daisies for a touch of deep blue.

Greenery will provide the bed and background for the above, and outnumber flowers about 3 to 1.

The box color will be a dark terra cotta.

SIZE:

The box is 36" x 6" x 6".

CONFIDENTIAL

TALKING FLOWERS - DIAGRAM

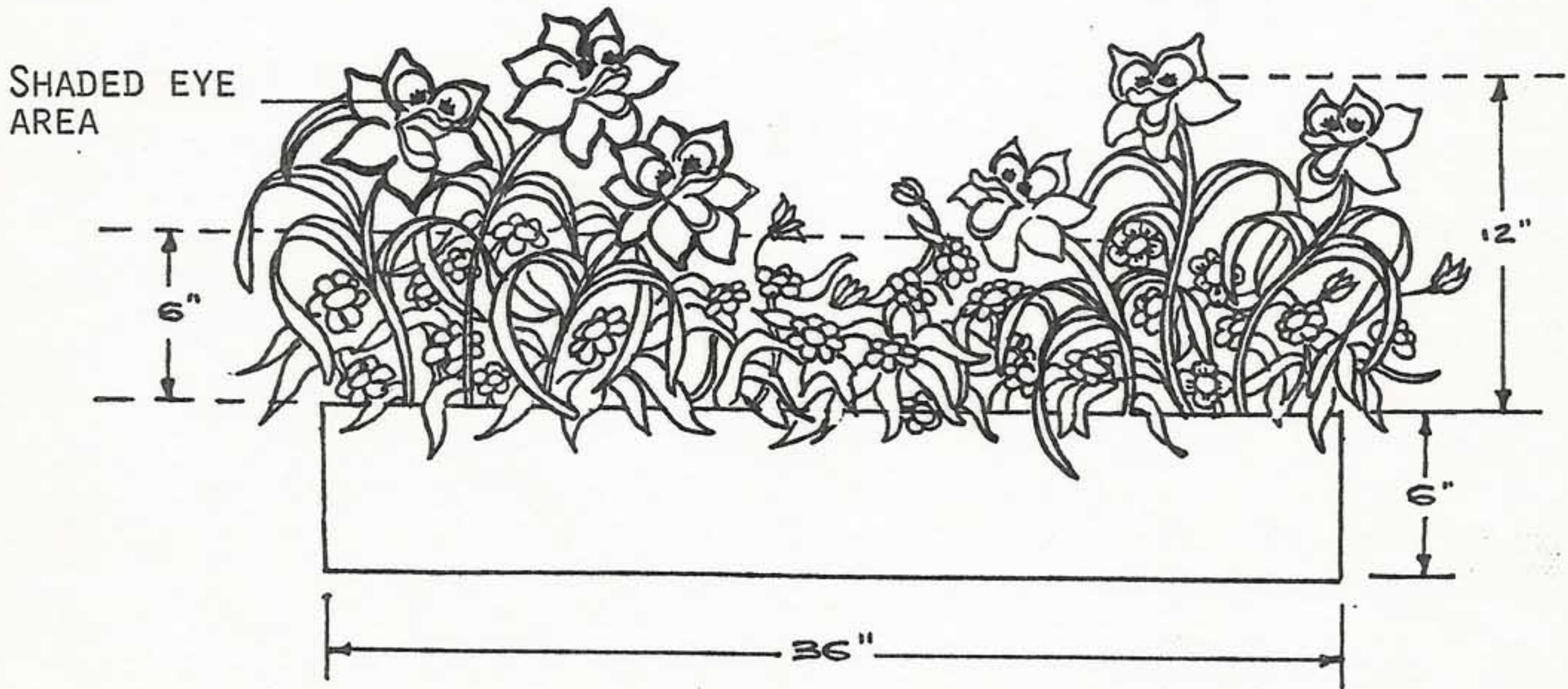
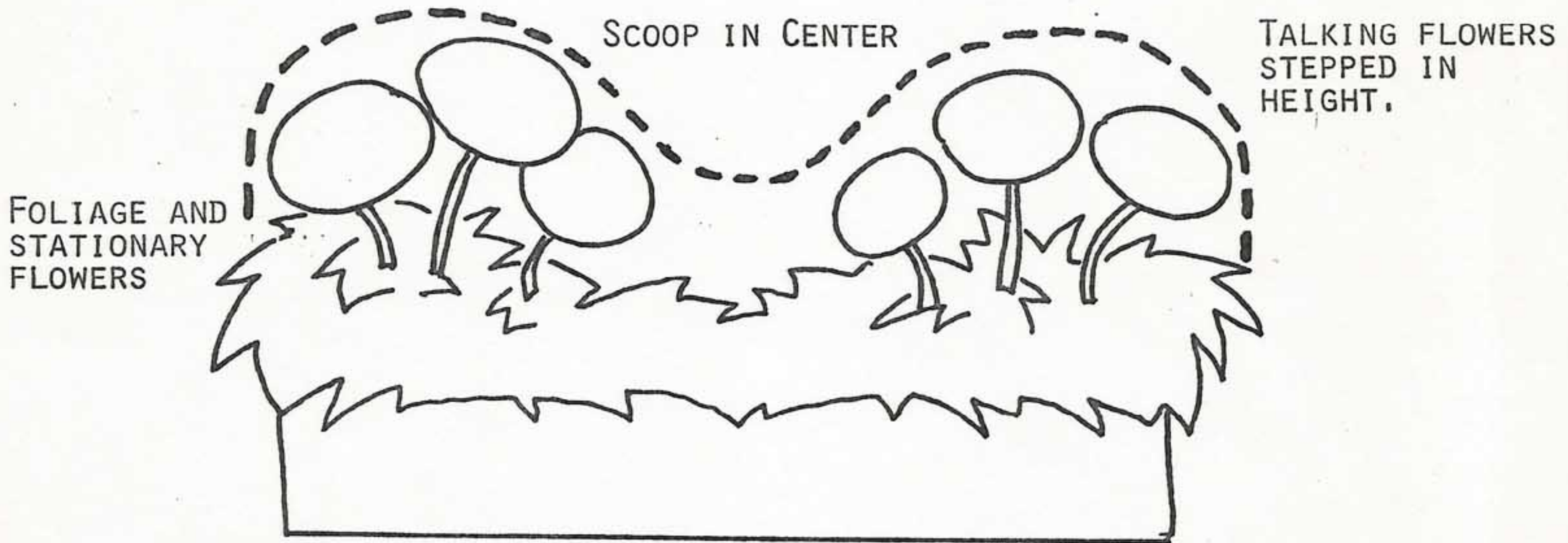

CONFIDENTIAL

ANALYSIS OF NEW ATTRACTION POTENTIAL

Pixie land BAND / PEPPER'S GHOST

<p>STRATEGY</p>	<ul style="list-style-type: none"> • Improves the adult experience. • Maintains or improves the child experience. • Does not diminish the restaurant perception. • Offers new or novel form of entertainment. 	<p>yes</p>	
		<p>yes</p>	
		<p>yes</p>	
		<p>yes</p>	
<p>★ ★ ★ ★ ★ ★ ★ ★ ★ ★ NEW ENTERTAINMENT ATTRACTION ★ ★ ★ ★ ★ ★ ★ ★ ★ ★</p>	<ul style="list-style-type: none"> • Are development costs required? How long? - How much? • Can it be cost effectively adapted to locations? • What is the time frame for field testing? • What is the time frame for rollout? • Are special installation skills required? • What are anticipated maintenance costs? • What are software support costs? • What is projected R.O.I. ? • What will its' life be after 100% R.O.I.? 	<p>yes</p>	
		<p>?</p>	
		<p>3 mo.</p>	
		<p></p>	
	<p>TIME & COST FACTORS</p>		<p>No</p>
			<p>low</p>
			<p>?</p>
			<p></p>

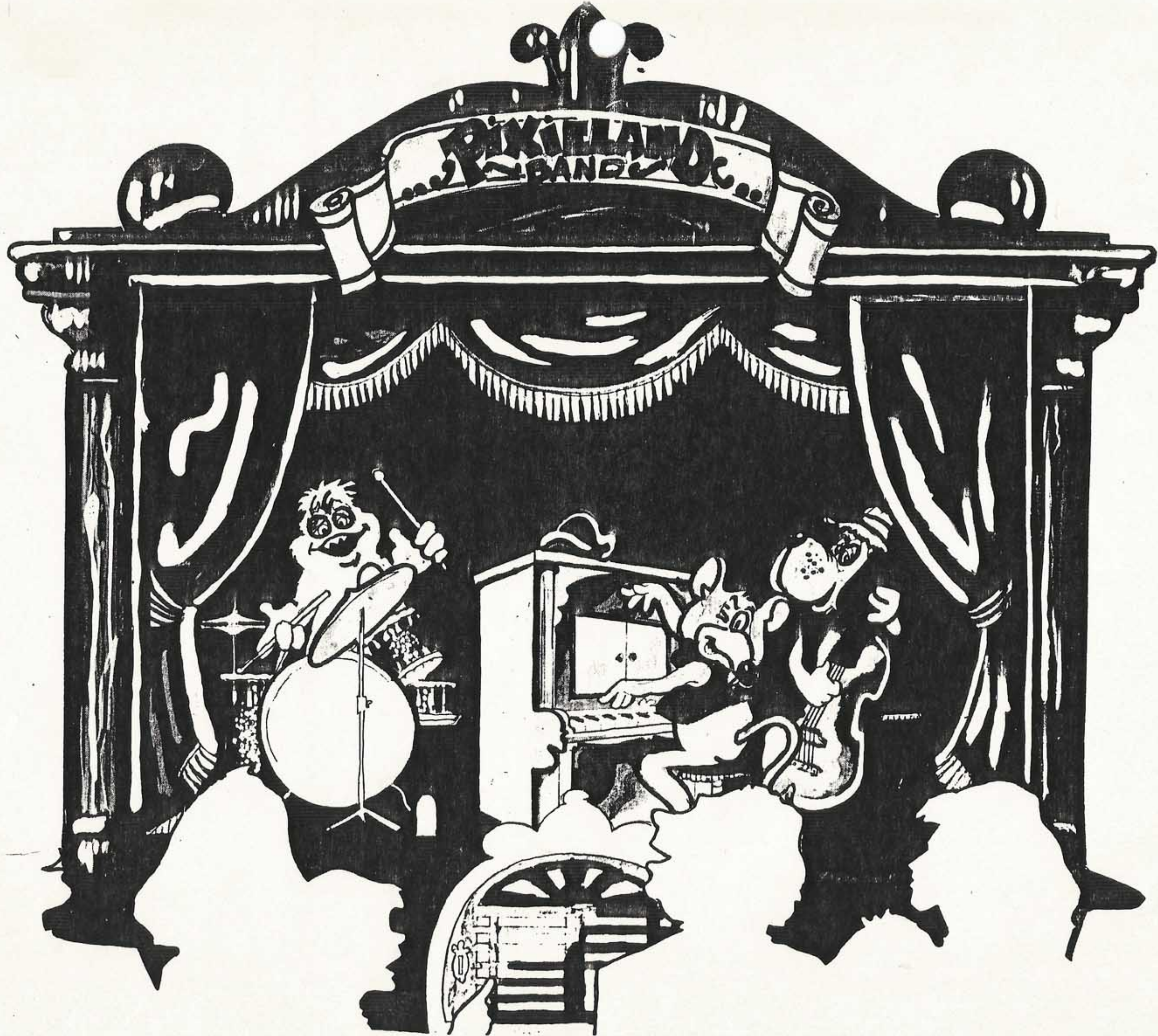

BIKILLAND BAND

ANALYSIS OF NEW ATTRACTION POTENTIAL

Interactive Live ENT.

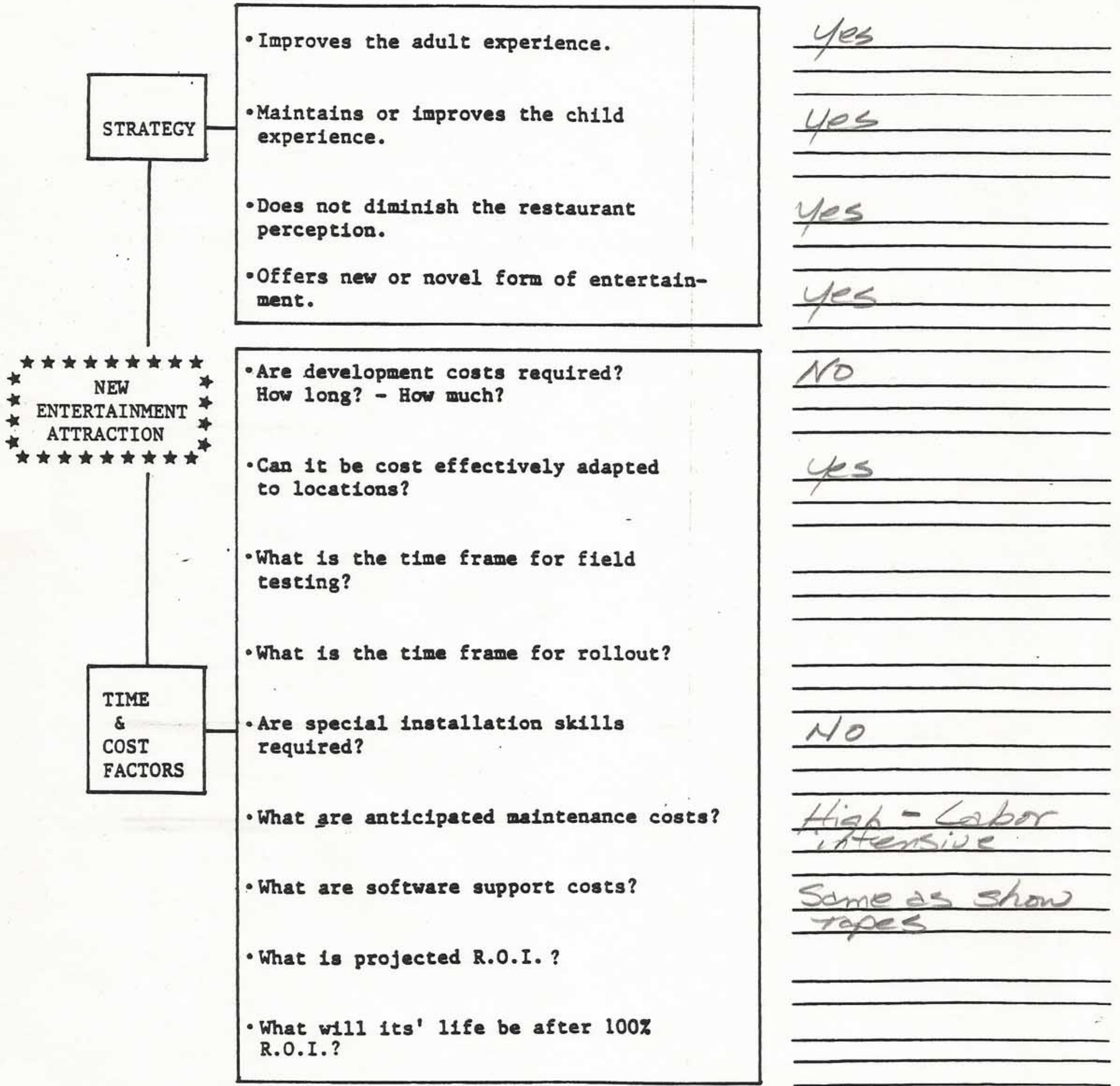

Yes

Yes

Yes

Yes

No

Yes

No

High - Labor intensive

Same as show tapes

Cowan Costumes, Inc.
 108½ S. Caddo
 Cleburne, TX 76031

QUOTATION

No. _____

Date November 27, 1987

Terms & Conditions _____

F.O.B. _____

Estimated Delivery _____

To Showbiz Pizza Time, Inc.
 Attn: Jul Kamen
 4441 W. Airport Freeway
 P.O. BOX 152077
 Irving, TX 75015

We are pleased to submit the following prices and specifications.

Quantity	Description	Price	Amount
1 +	CHUCK E. CHEESE LIVE SHOW CHARACTER Complete Character	\$ 940.00	
	Parts breakdown if ordered individually:		
	Head - \$ 465.00		
	Hands - 23.00		
	Feet - 100.00		
	Vest - 50.00		
	Body - 275.00		
	Body fat - 75.00		
	Body fat cover - 75.00		
	<hr/>		
	Total - \$1,063.00		
Quotation Prepared By <i>Karen Cowan</i>		Total	

ANALYSIS OF NEW ATTRACTION POTENTIAL

Face Bodied Cybers

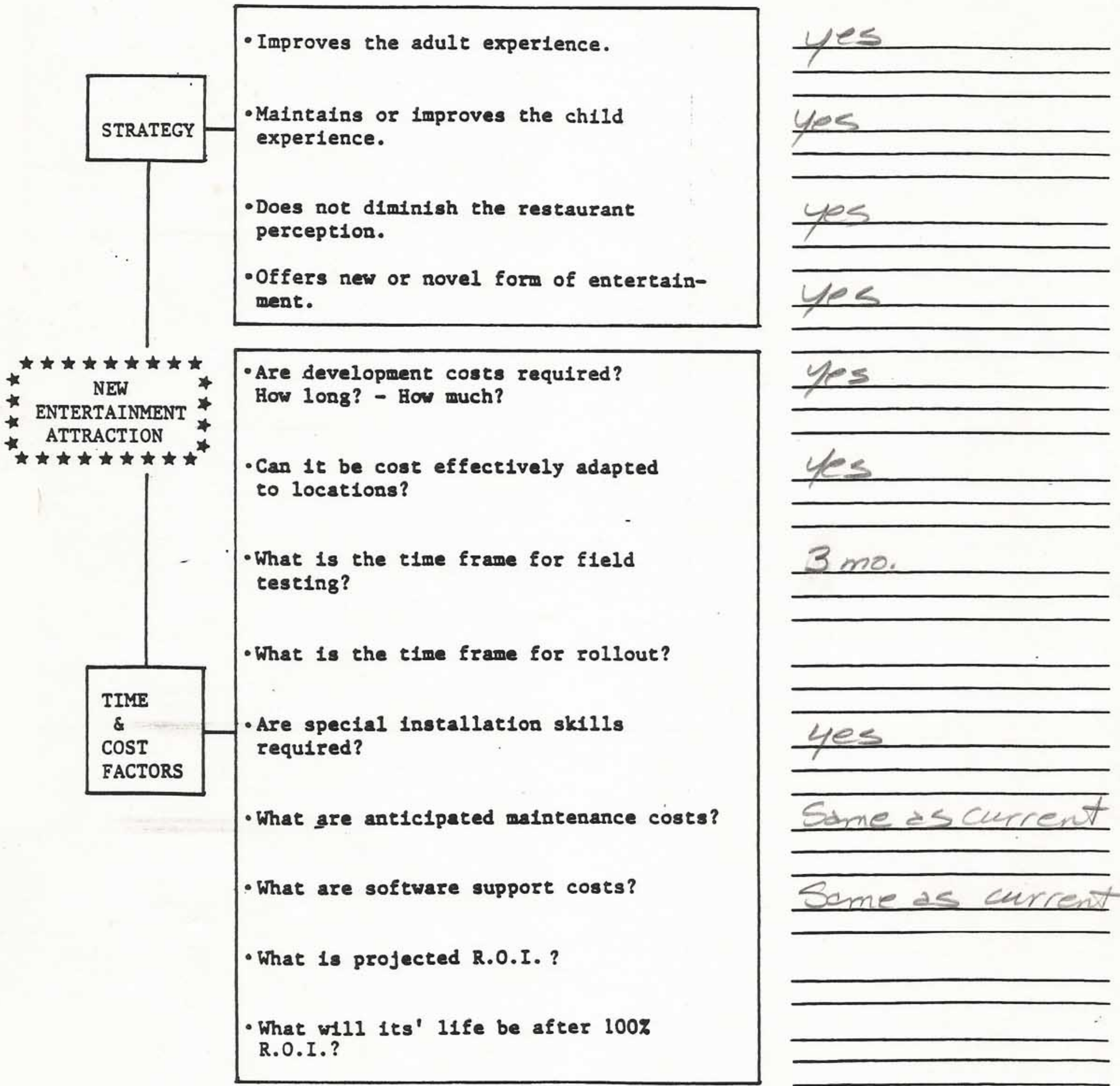

SPECIFICATIONS FOR CHUCK E.'S STAGE HOME

1. DEMOLITION OF EXISTING STAGE:

Responsibility of location

2. PRE-FABRICATED HOUSE:

VENDOR: CORMAN AND ASSOC. INC.
881 Floyd Dr.
Lexington, KY 40505

606/233-0544

CONTACT: Ted Corman

LEAD TIME: Roughly 8 weeks (depending on the season)

PRICE: 10' 6" House \$9,600.00
12' House \$10,400.00

INSTALLATION: Not included but can be arranged
if necessary.

SHIPPING: Additional; F.O.B. Lexington, KY.

3. LOWER HALVES OF CENTER STAGE CHARACTERS:

Chuck E., Jasper and Helen. (Includes rocking chair
for Jasper, porch swing for Helen and base for Chuck
E.)

VENDOR: C.P.I.
819 W. Lunt Ave.
Schaumburg, IL 60193

800/843-2982

CONTACT: Gene Bullard

LEAD TIME: 2-4 weeks

PRICE: Set of 3: \$2,500.00

INSTALLATION: Installation personnel provided by
ShowBiz Home Office, price to be
determined.

SHIPPING: Additional, F.O.B. Chicago

4. SILK FLOWER PACKAGE:

VENDOR: DESIGN PLANTS, INC.
3361 Boyington
Suite 160
Carrollton, TX 75006

214/239-6981

CONTACT: Kathy Blair

LEAD TIME: 4 Weeks

PRICE: Complete front of the house coverage - \$800.00

INSTALLATION: No special skills required. Flowers and bushes are pre-arranged and set into foam. Each section is labeled for placement into recessed flower bed area provided with pre-fab house.

SHIPPING: Additional, F.O.B. Carrollton, TX

5. ELECTRICAL REQUIREMENTS:

All parts and materials are to be provided and installed by a qualified electrician engaged by the requesting location according to local codes.

ITEMS NEEDED:

1. Two ceramic pull-chain fixtures for 100W work lights in Pasqually's and Munch's rooms
2. 20' unistrut for mounting character spotlights
3. Six Cyrydom TD 1210 solid state relays for actuation of character spots
4. 38' of 4-10W candelabra base Christmas lights spaced 6" apart
5. Five Altman ellipsoidal spotlight fixtures with adj. iris (3.5 x 12 MC) and five 250W quartz EHT bulbs.
6. Four duplex outlets
7. Two 8' halo tracks

8. Eight halo L704 black fixtures with eight 150W clear spotlight bulbs (available from light bar on remodels)
9. Three manual dimmers (600W or greater)
10. Classic coach lantern (black, 13-15 inches) for porch
11. Six halo L704 black fixtures with six 150W clear spot bulbs (for character lights in Pasqually and Munch rooms and available from light bar on remodels)
12. Electrical box for mounting of six solid stage relays
13. Seven outlet boxes
14. Four 20 AMP breakers
15. Four ivory outlet covers
16. Six halo L973 canopy adapters (available from light bar on remodels)
17. 4 - 3/8" all-thread pieces for mounting of uni-strut
18. Miscellaneous 12/2 wire and 3/4" conduit as needed for installation

FOUR CIRCUITS WILL BE INSTALLED AS FOLLOWS:

1. 20A circuit #1 worklights, convenience outlet, porch light and Christmas lights
2. 20A circuit #2 (2) 8' halo tracks inside roof of house
3. 20A circuit #3 character spot lights (5-250 watt)
4. 20A circuit #4 character swivel lights (6-150 watt)

CHUCK E. CHEESE'S 10' 6" STAGE HOME

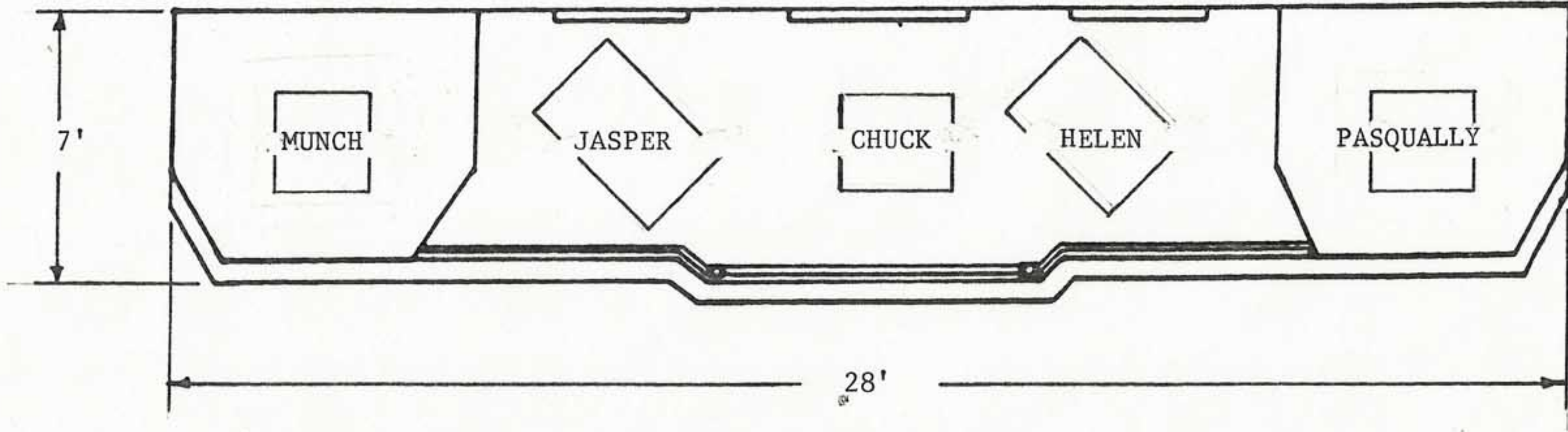

CHUCK E. CHEESE'S 12' STAGE HOME

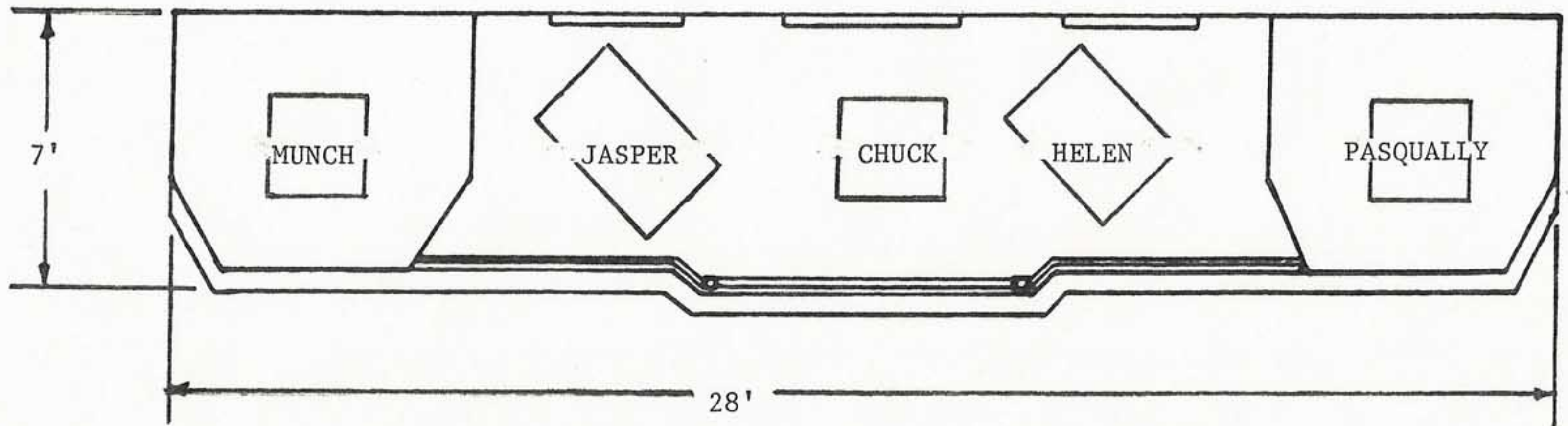

CHUCK E. CHEESE

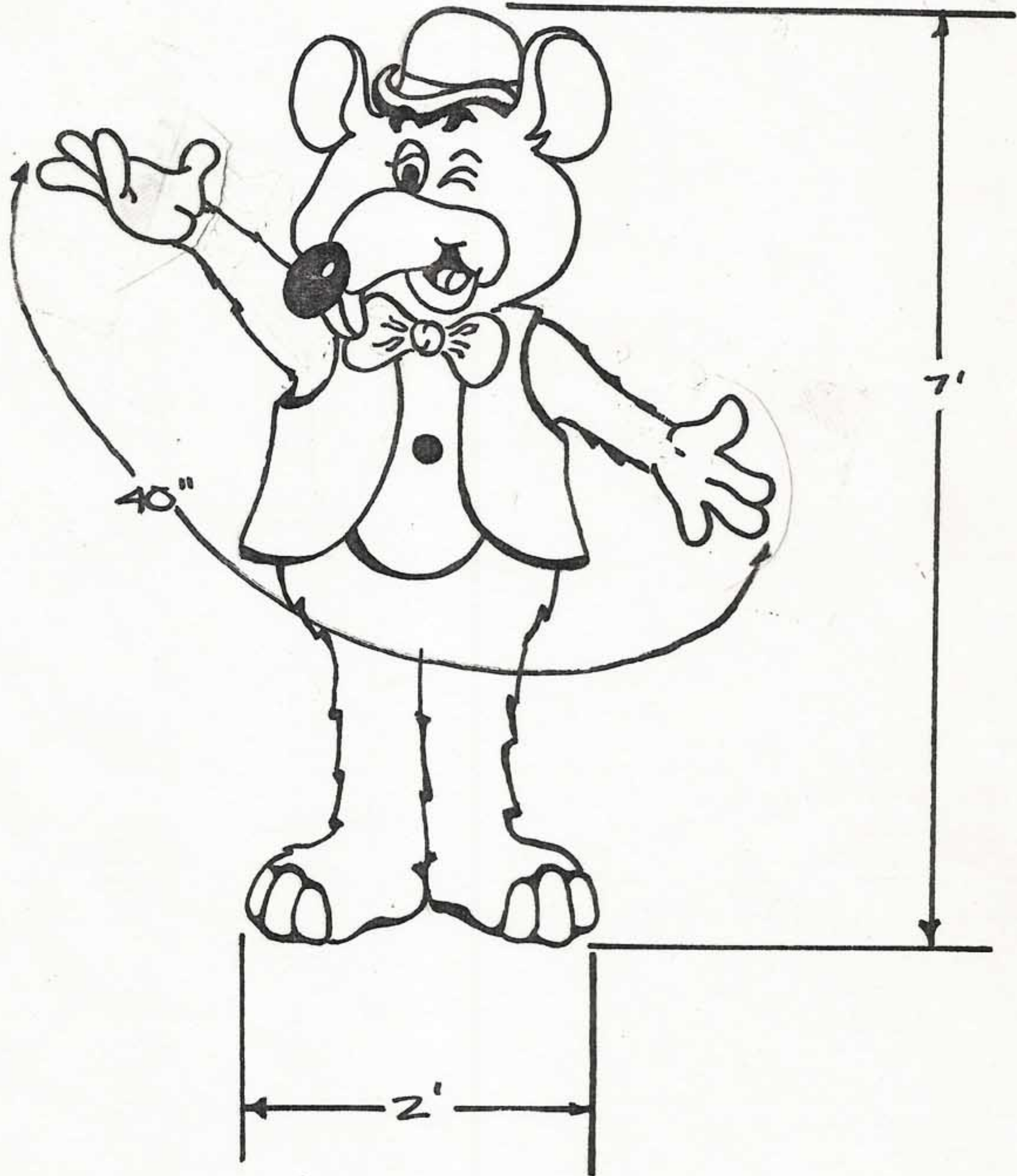

HELEN HENNY

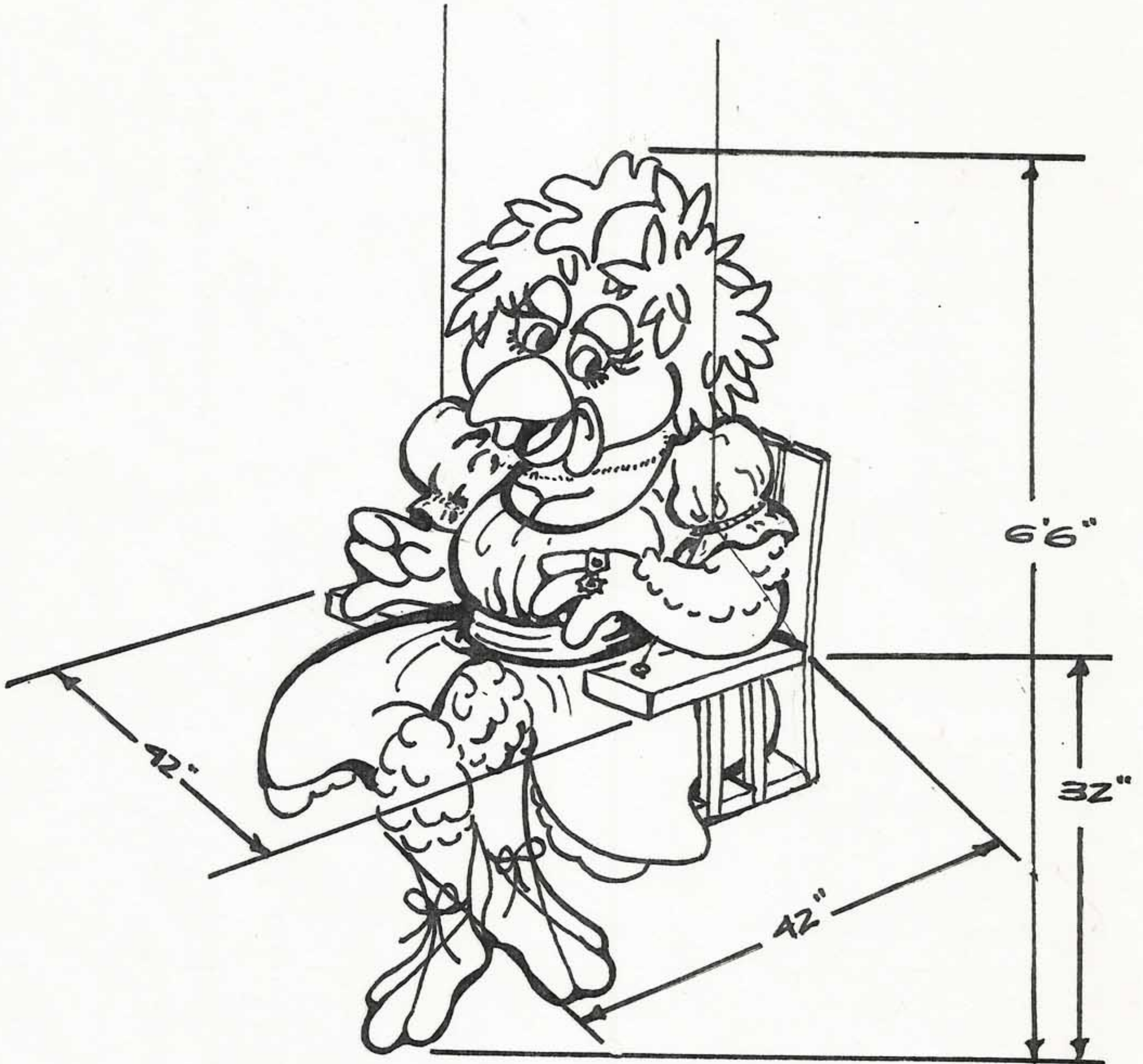

JASPER T. JOWLS

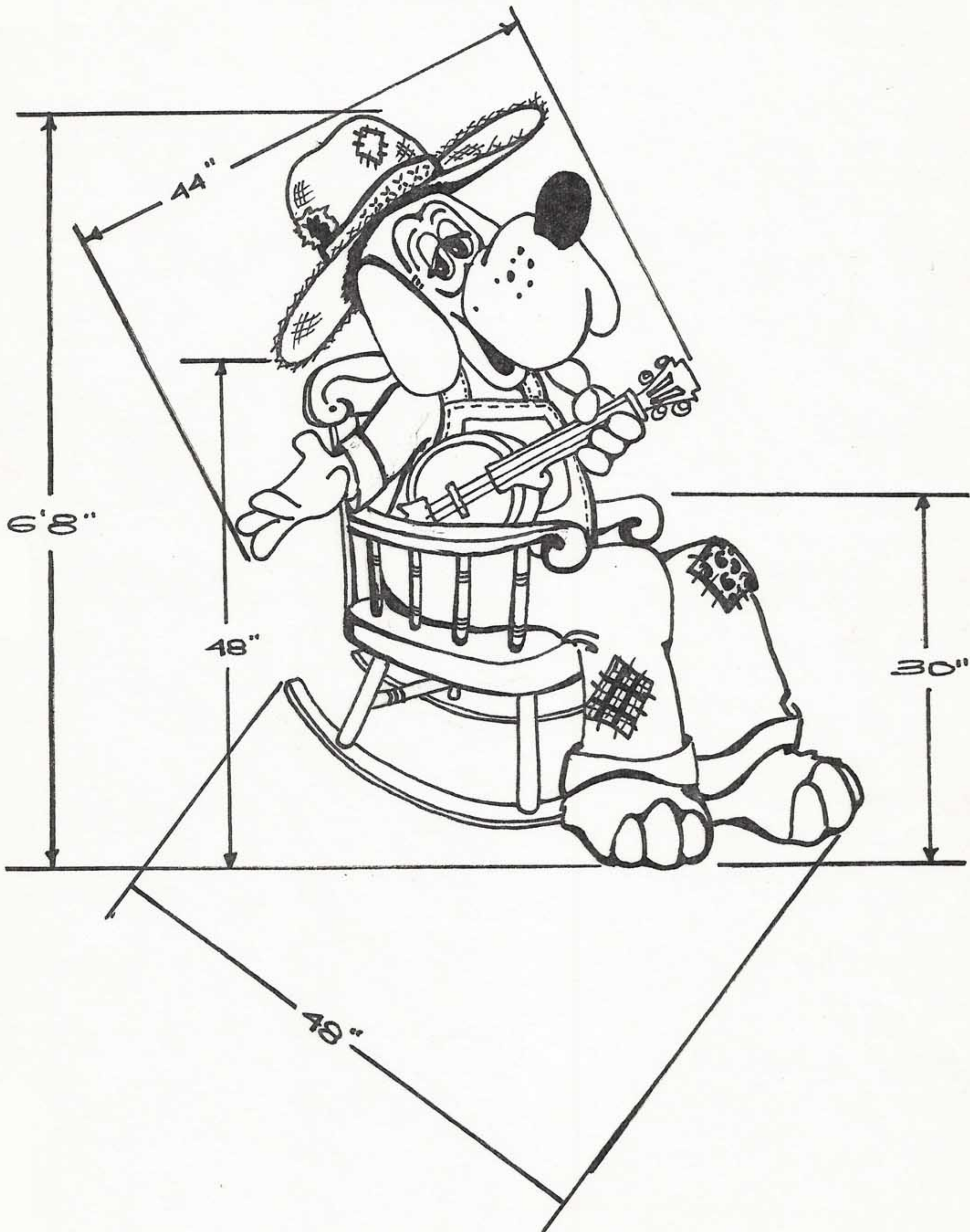

PASQUALLY



MR. MUNCH



Corman & Associates inc.

December 30, 1987

Show Biz Pizza Time, Inc.
4441 W. Airport Freeway
Irving, Texas 75062

Attn: Jul Kamen

Dear Jul,

Please find enclosed 3 designs for the Chuck E.
Cheese area and the accessory sheet.

If you have any questions please call 254-1880.

Sincerely,

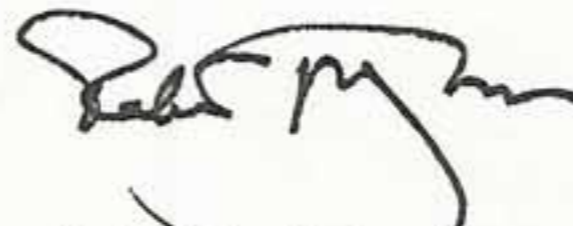

Robert Johnson
Design/Art Director

RRJ/csk

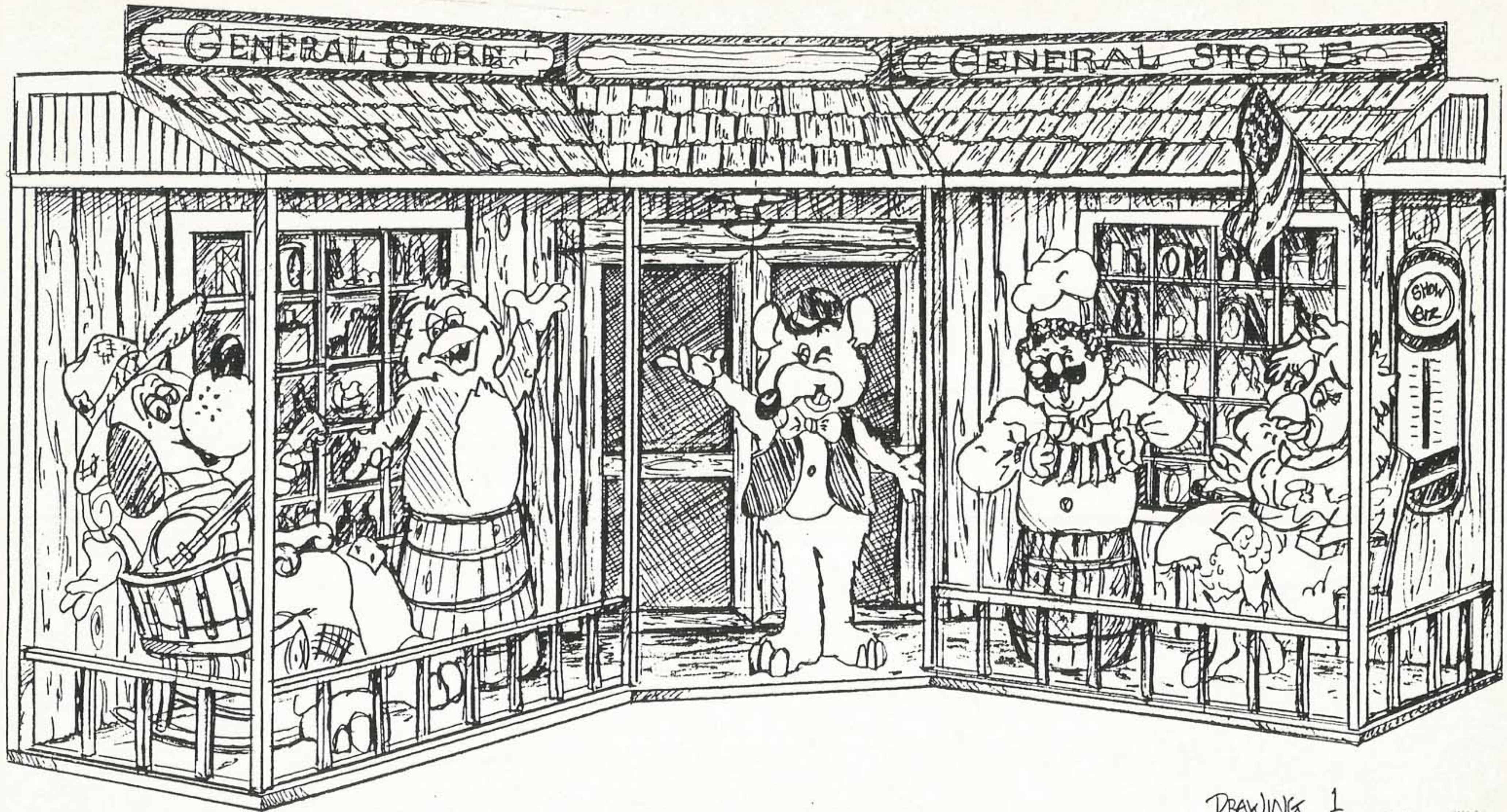

DRAWING 1
SHOWBIZ PIZZA TIME



CORMAN & ASSOCIATES INC.

881 Floyd Drive
Lexington, Kentucky 40505
606-233-0544 / 254-1880

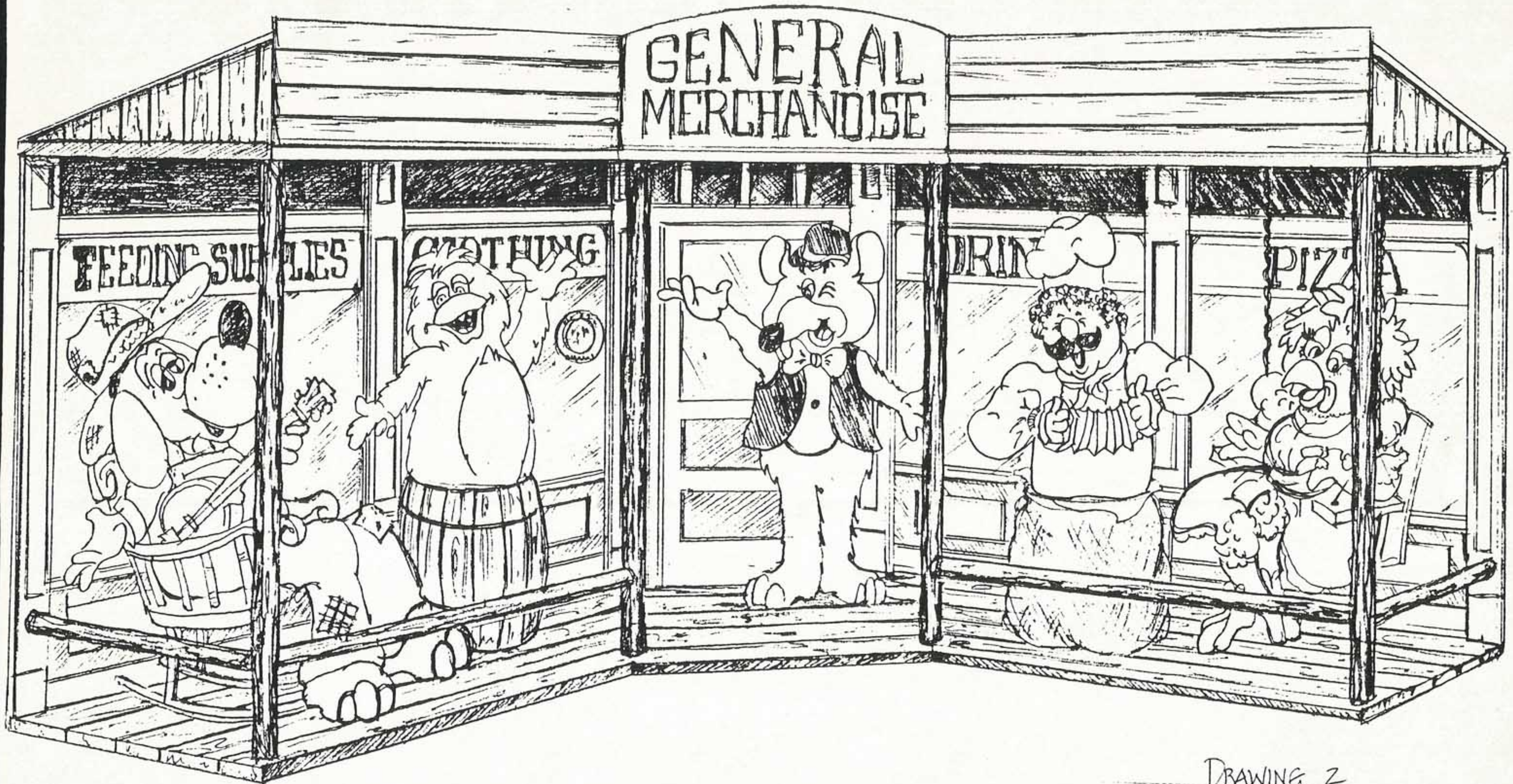

DRAWING 2
SHOWBIZ PIZZA TIME



CORMAN & ASSOCIATES INC.

881 Floyd Drive
Lexington, Kentucky 40505
606-233-0544 / 254-1880

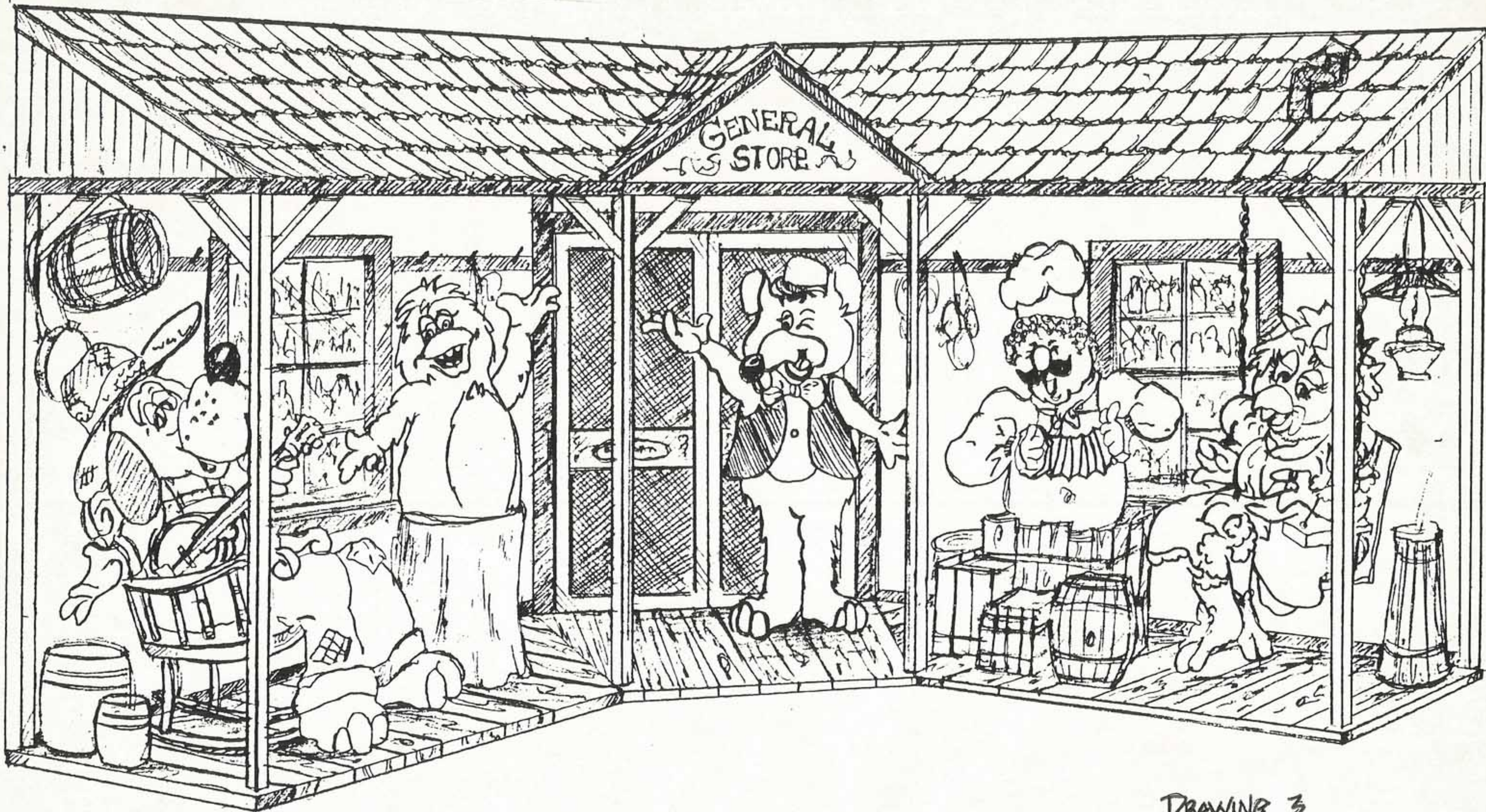

DRAWING 3
SHOWBIZ PIZZA TIME



CORMAN & ASSOCIATES INC.

881 Floyd Drive
Lexington, Kentucky 40505
606-233-0544 / 254-1880

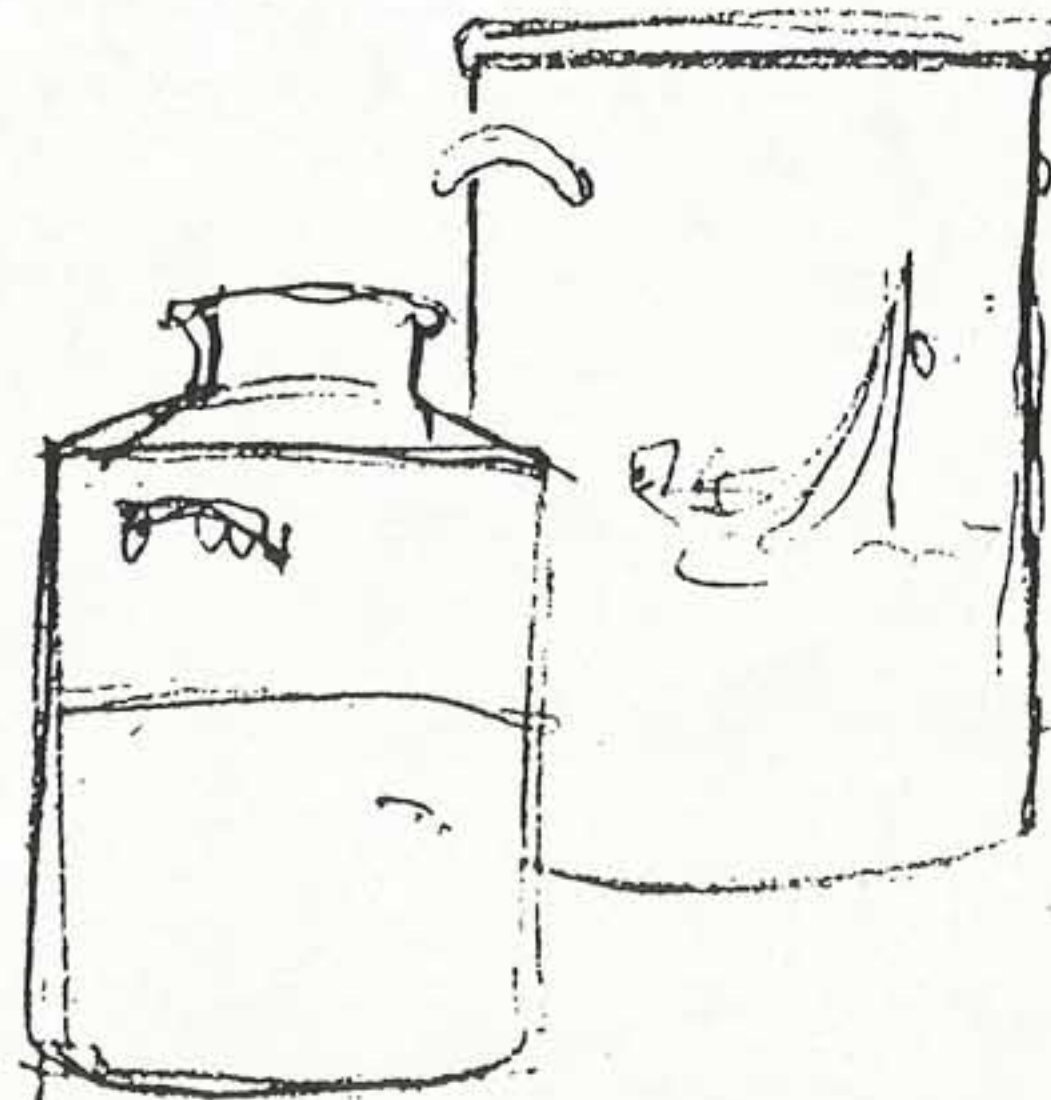
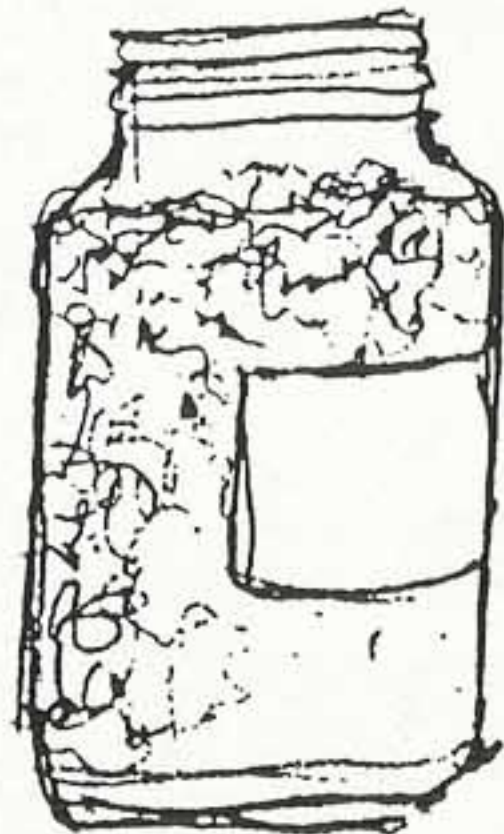
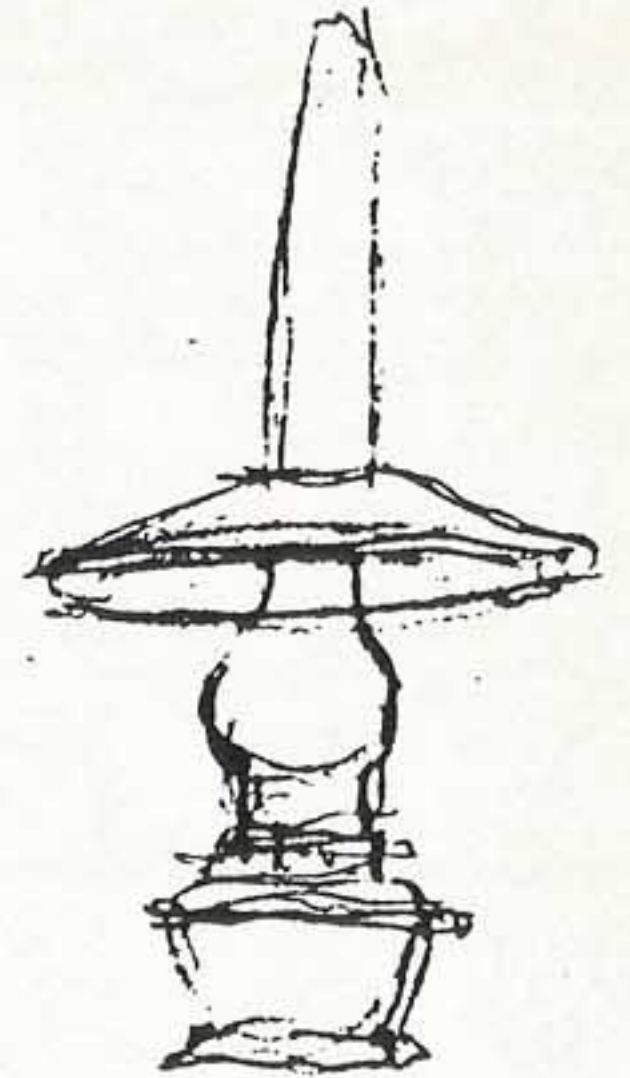
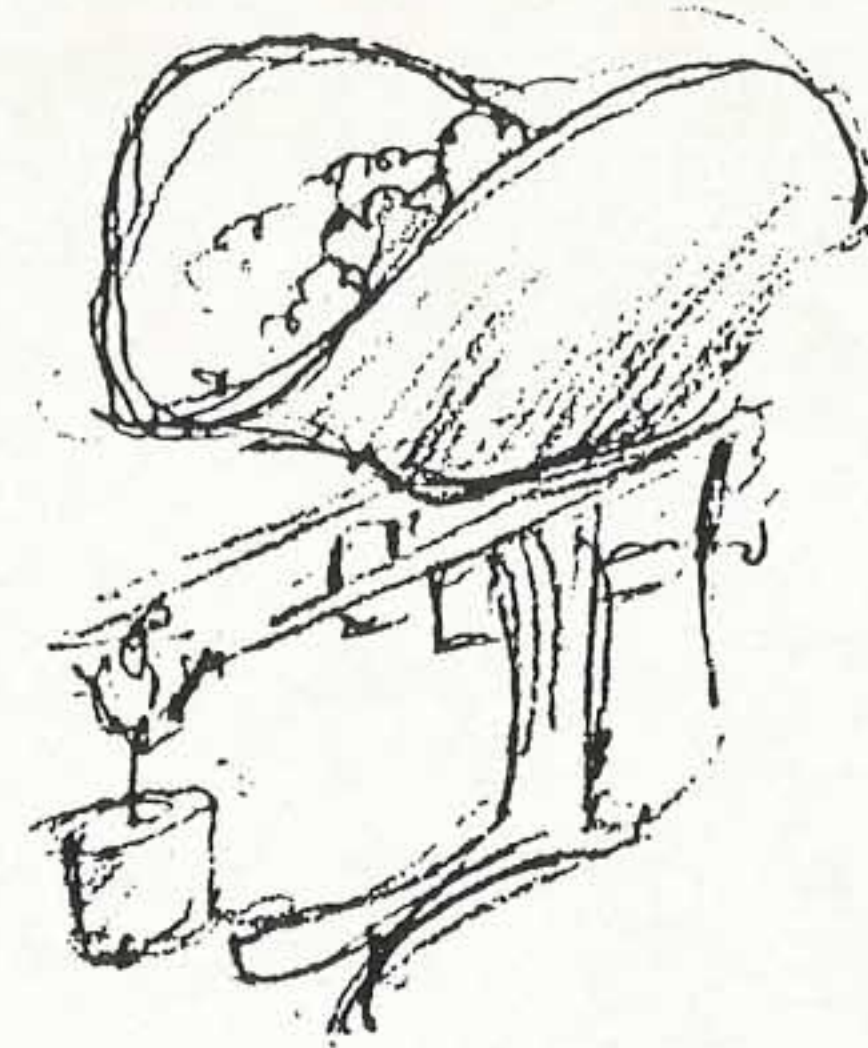
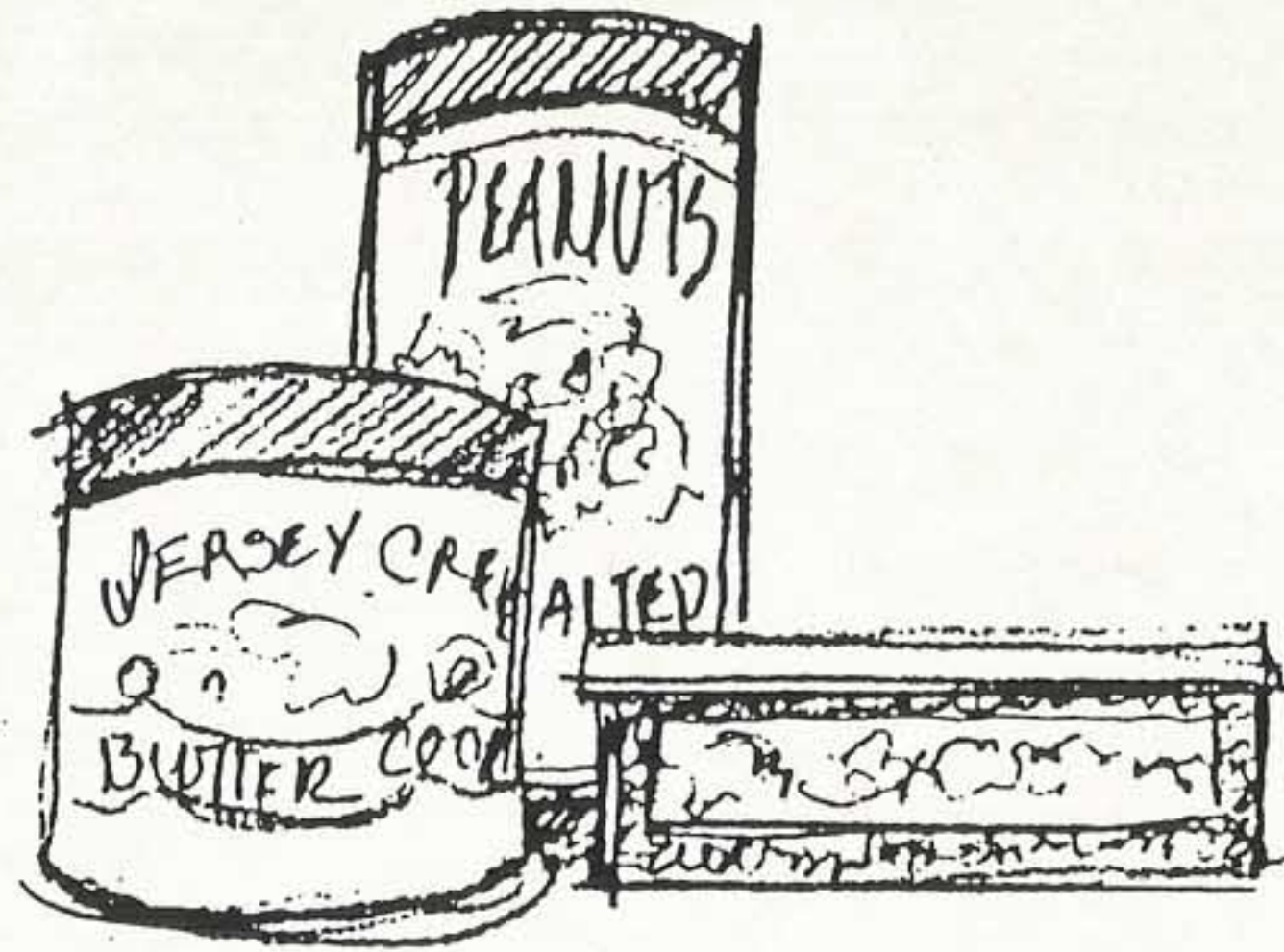
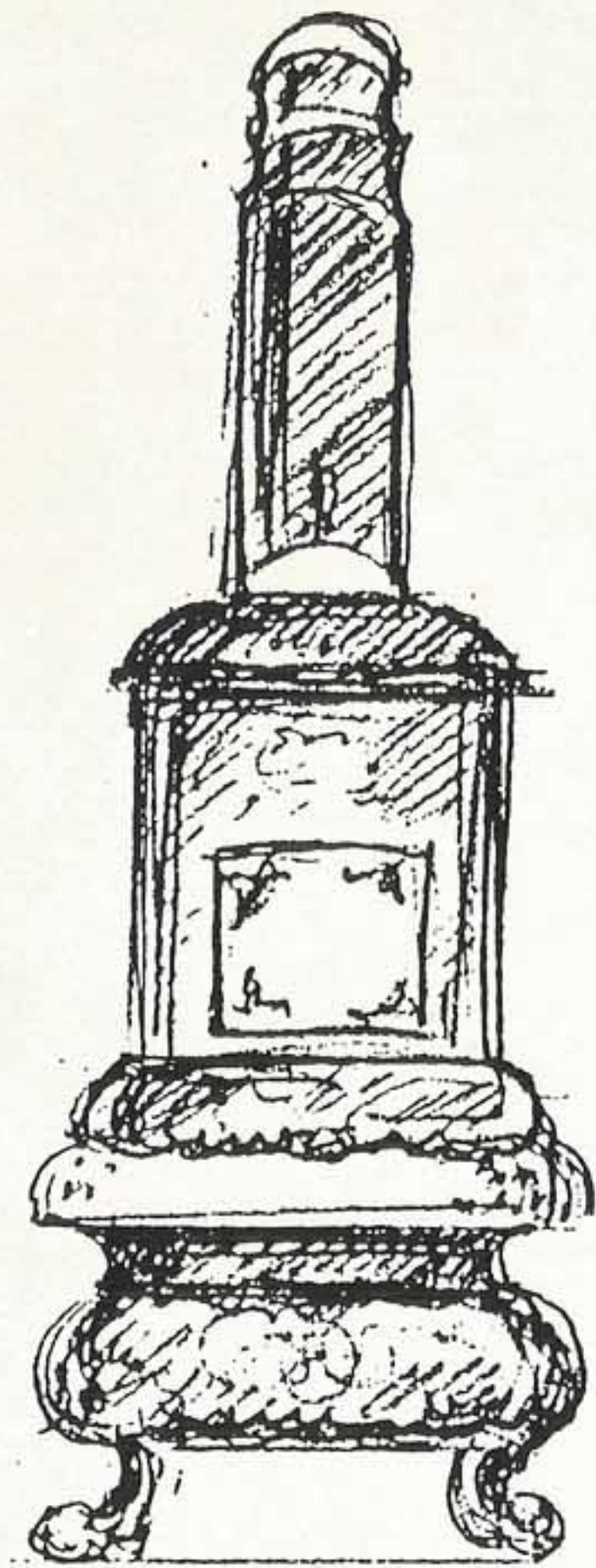

CORMAN & ASSOCIATES INC.

881 Floyd Drive
Lexington, Kentucky 40505
606-233-0544 / 254-1880

sharp, clean, contemporary

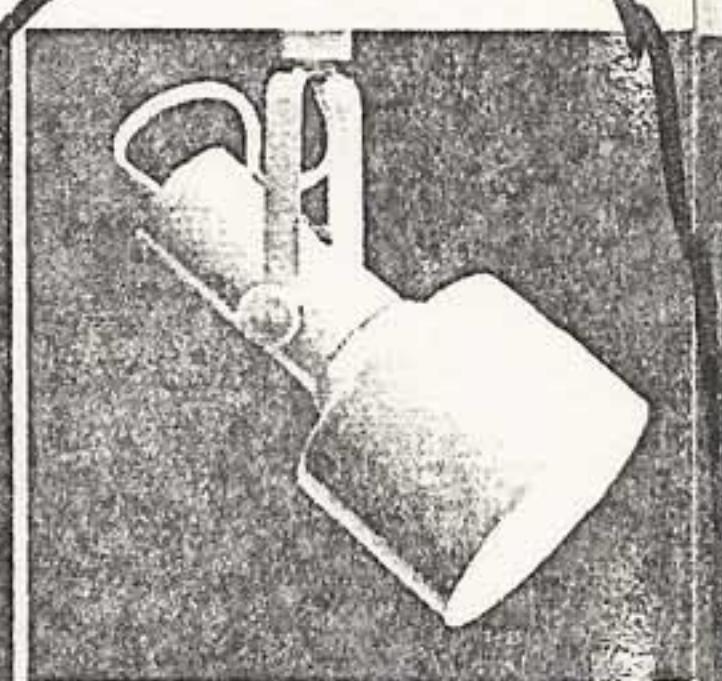
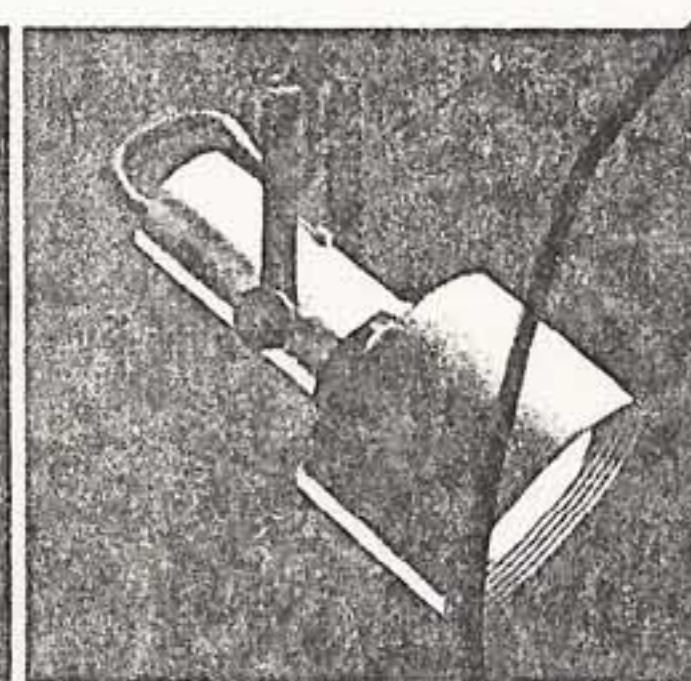
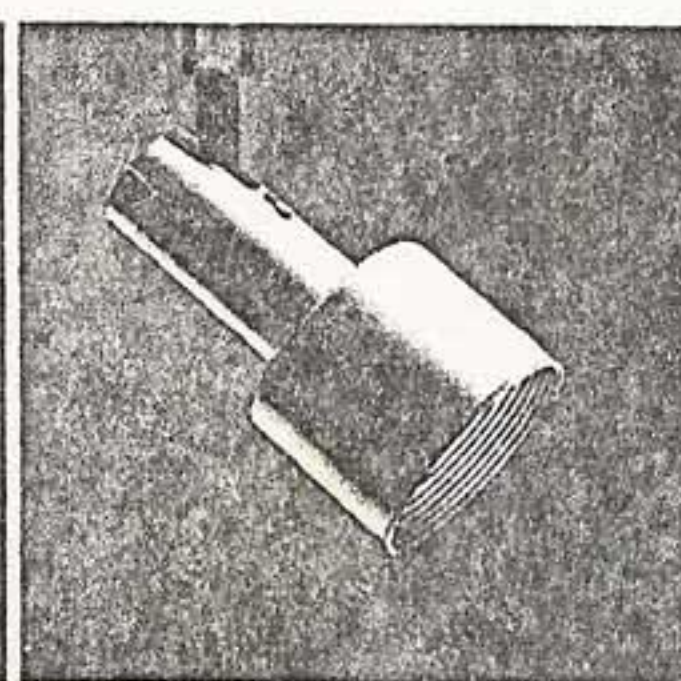
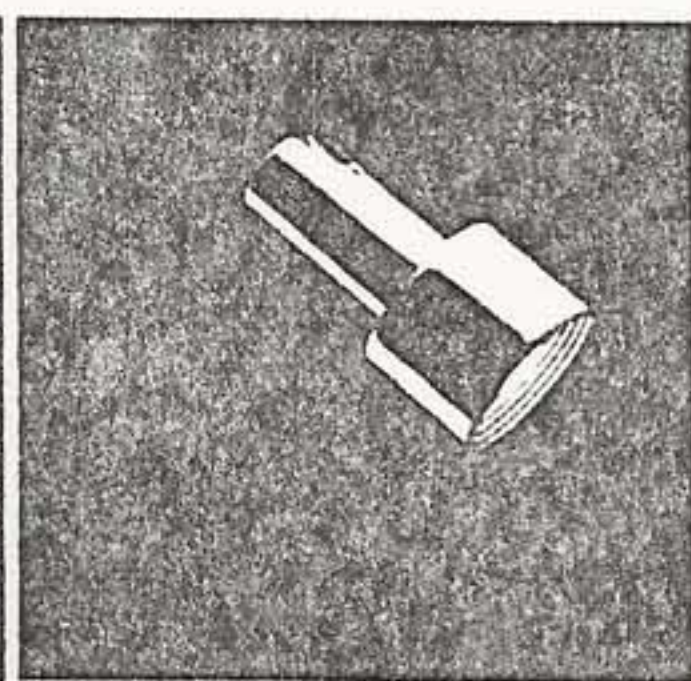
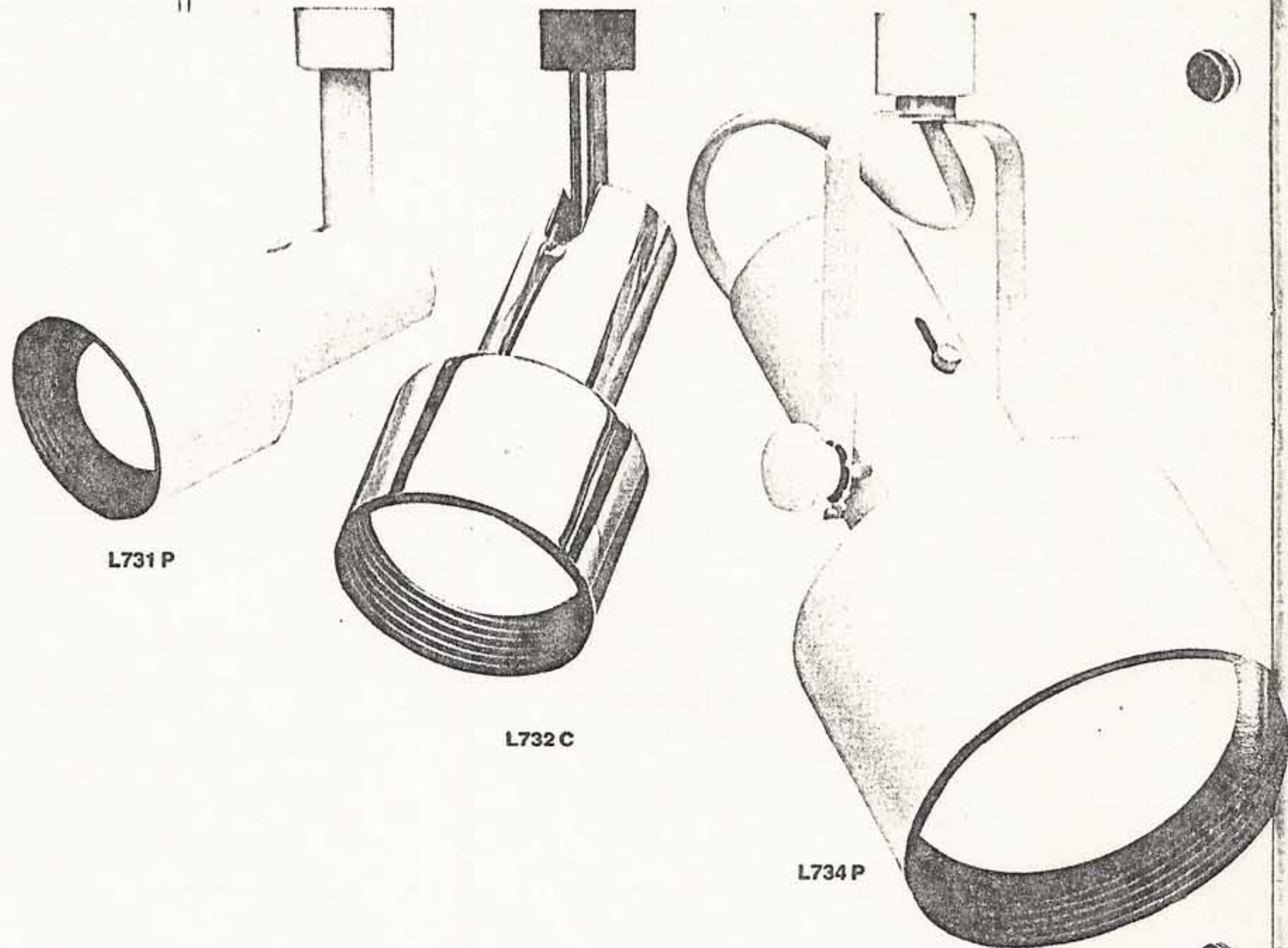

L731

R-Lamp, Matte Black Coilex Baffle. For use with 40W R16 (Halo Z9) or 30/50W R20 lamps. Color codes: P, BZ, B, C, W

L	5 ⁵ / ₈ "	143 mm
W	3"	76 mm
E*	8 ¹ / ₄ "	210 mm
*Maximum Extension		



L732

R-Lamp, Matte Black Coilex Baffle. For use with 30 50W R20 or 100W R25 (Halo Z10) lamps. Color codes: P, MB, BZ, B, G, W

L	6 ⁵ / ₈ "	168 mm
W	3 ⁵ / ₈ "	92 mm
E*	9 ³ / ₈ "	238 mm
*Maximum Extension		

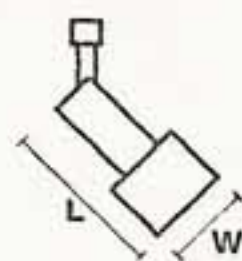

L733

R-Lamp or ER-Lamp, Matte Black Coilex Baffle. For use with 75W R30 or 75W ER30, 100W R25 (Halo Z10) lamps. Color codes: P, MB, BZ, B, C, W

L	8 ³ / ₄ "	222 mm
W	4 ⁷ / ₈ "	124 mm
E*	11 ¹ / ₈ "	283 mm
*Maximum Extension		

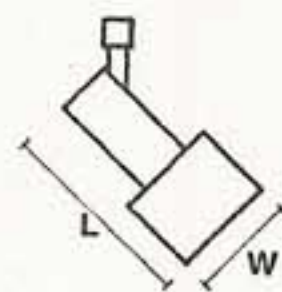

L734

R-Lamp or ER-Lamp or PAR Lamp, Matte Black Coilex Baffle. For use with 150 300W R40, 150W PAR 38, 120W ER40 or 75W ER30 lamps. Color codes: P, MB, AL, BZ

L	10 ¹ / ₂ "	257 mm
W	5 ⁷ / ₈ "	149 mm
E*	12 ⁵ / ₈ "	321 mm
*Maximum Extension		

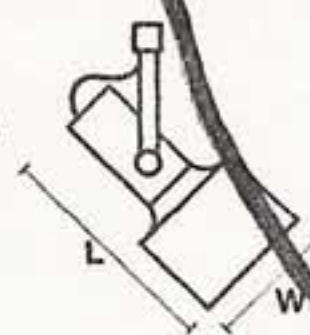

L704

R-Lamp, ER-Lamp or PAR Lamp. For use with 150/300W R40, 150W PAR 38, 75W ER30 or 120W ER40 lamps. Accessories: L201 Accessory Holder. Color codes: P, MB

L	10"	254 mm
W	5 ⁷ / ₈ "	149 mm
E*	12 ¹ / ₂ "	318 mm
*Maximum Extension		

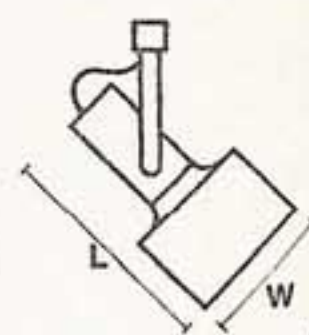

The Halo Power-Trac line offers a creatively designed and engineered lighting system for today's needs. The wide selection of accessories available provides even greater flexibility in lighting direction, intensity, position and color hues—allowing highly individualized lighting designs. These accessories complement both commercial and residential units (refer to individual accessory for specific application), and can be utilized by either the Miniature or Raceway Trac.

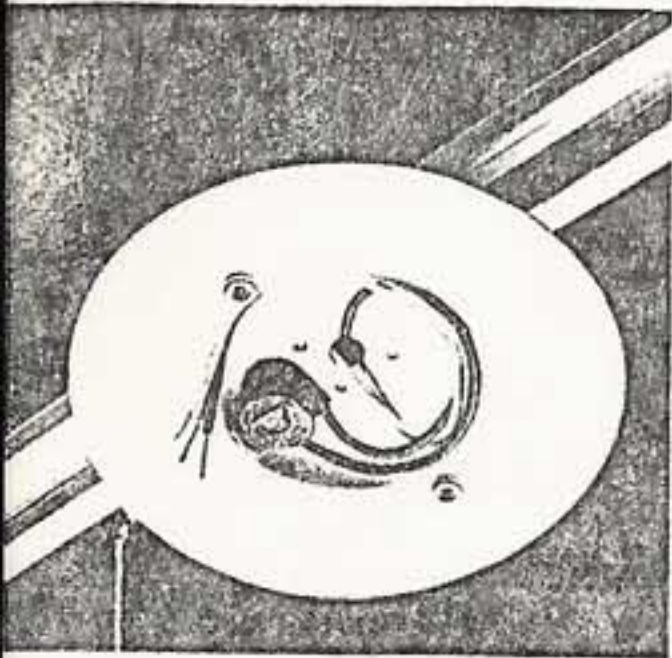

L956—Showroom Adapter Fixture. Allows canopy mounted fixture (chandelier, etc.) to be suspended from single-circuit track. Will hold up to 35 lbs. fixture, can be switched on and off via track or by pull chain on adapter. Color code: P

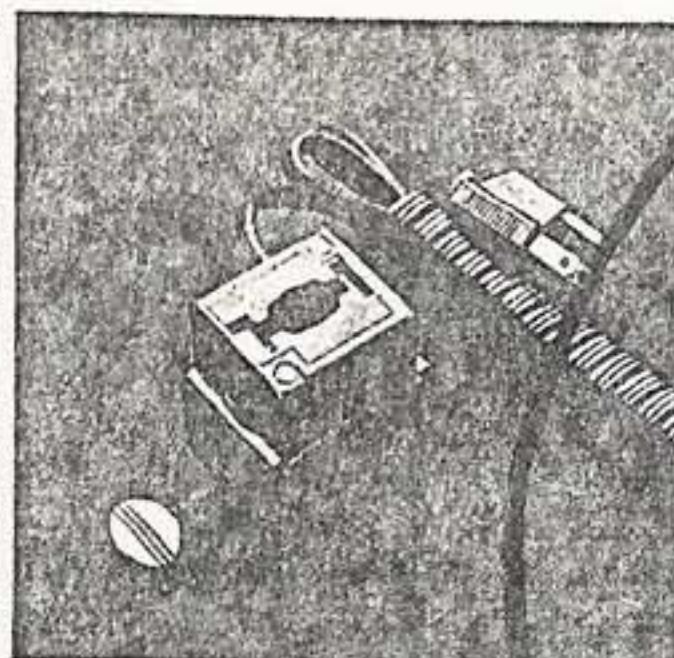

L972—C Clamp Adapter. Can be mounted on pipe up to 2" dia. (51 mm) or any flat protruding surface. Complete with 6' (183 cm) 3-wire cord with 3-prong grounded plug. Color code: MB

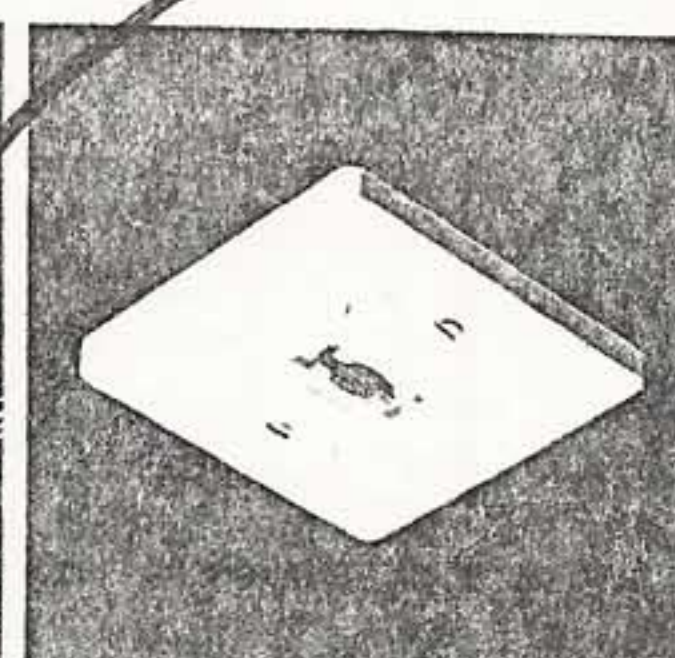

L973—Canopy Adapter. Mounts permanently to outlet box. 4½" sq. (114 mm). Allows any lampholder to 300W maximum to be converted to canopy installation. Color codes: P, MB

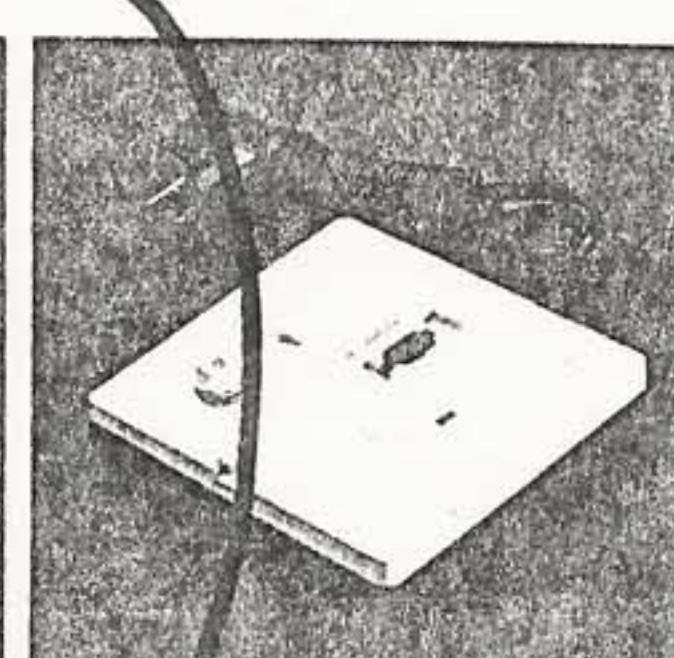

L1974—Weighted Base Adapter. For portable use. May also be used with L2001 Adapter and low voltage lampholders. Padded base 5¾" sq. (137 mm). Complete with 6' (183 cm) 3-wire cord with 3-prong grounded plug. Rotary on-off switch. Color codes: P, MB

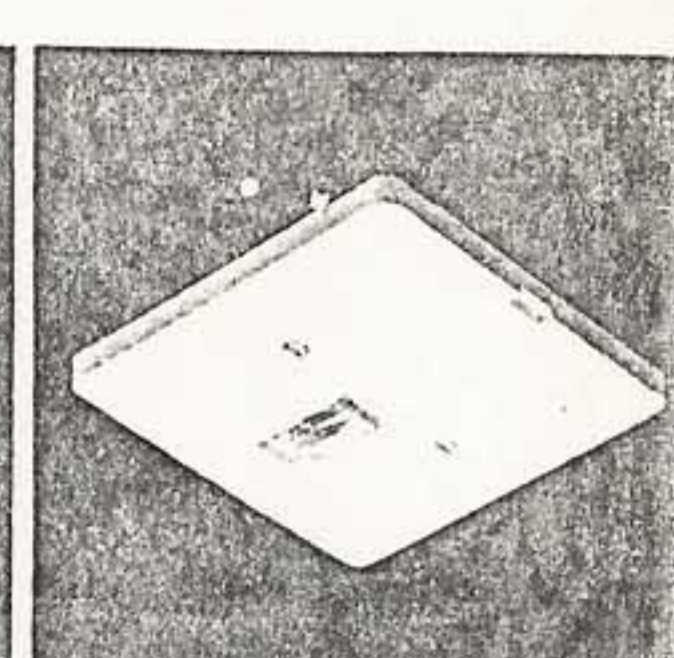

L1973—Low Voltage Canopy Adapter. Allows use of L2001 Solid State Adapter or lampholders with integral solid state transformer in canopy mount installations. Mounts permanently to junction box. 5¾" (137 mm) sq. Color codes: P, MB

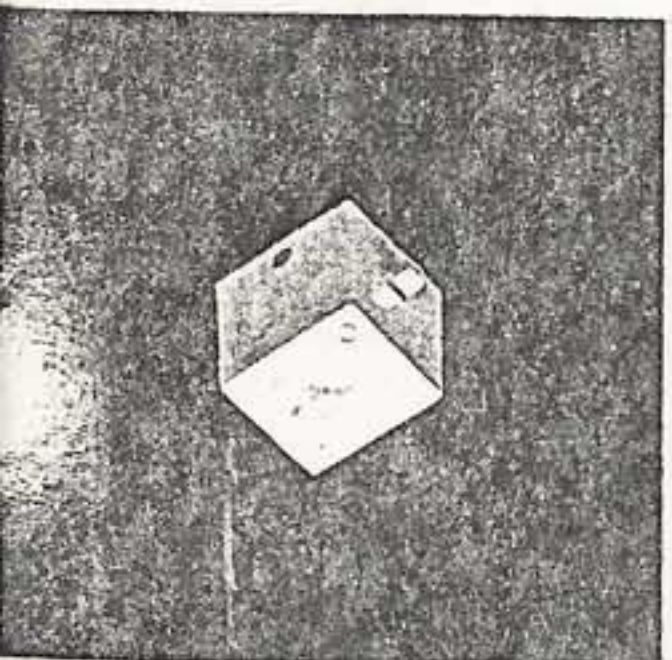

L965—Lampholder Converter converts all lampholders for use with old style L60 and L160 series track. Color codes: P, MB

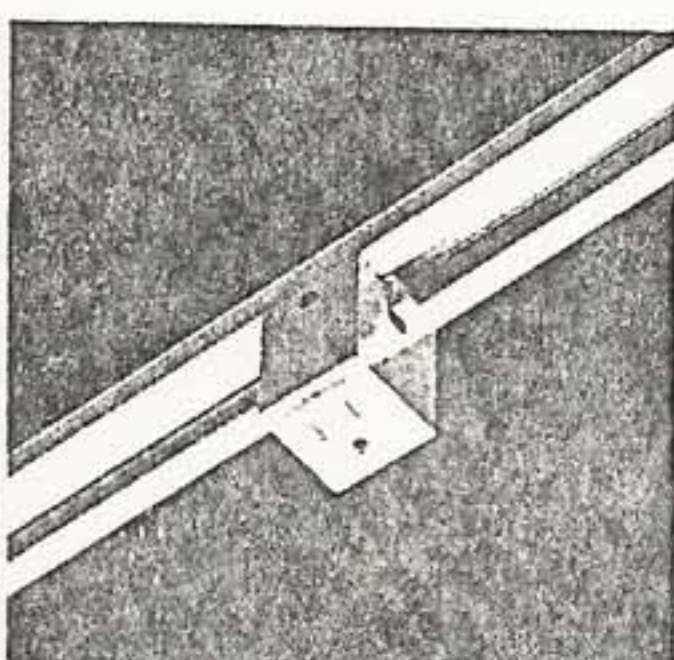

L966—Outlet Adapter. Provides a receptacle for swag lights or other electrical equipment. Accepts three prong grounded plug. 15 amps maximum. Use with single circuit trac only. Color code: P

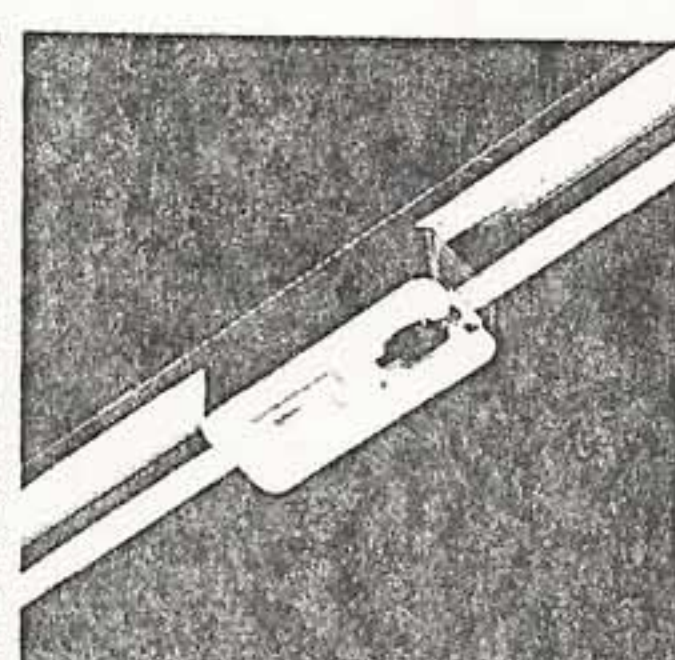

L967—Lampholder Adapter with switch. Converts lampholders to on/off switched unit. Use with single circuit trac only. Maximum of 300 watts. Color codes: P, MB

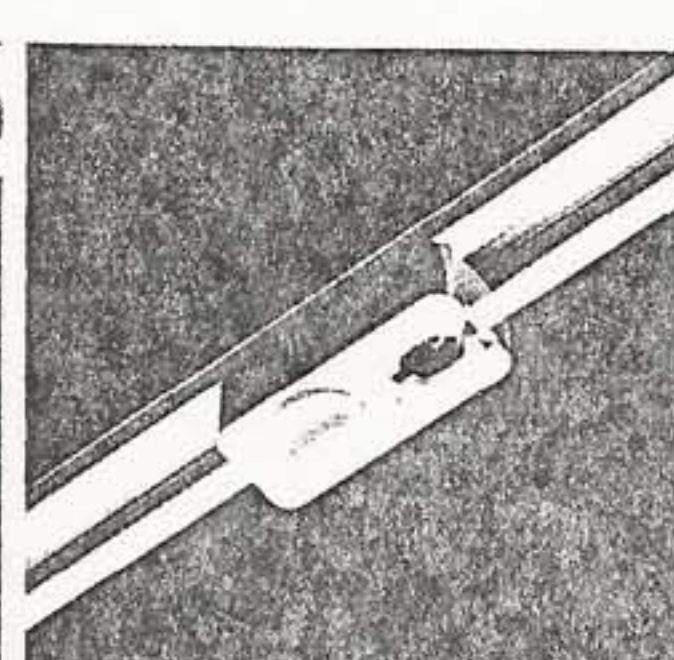

L968—Lampholder Adapter with Dimmer Switch. Converts lampholder to a dimmer and on/off switched unit. Will control up to 150W lamp. Cannot be used with Low-Voltage units. For use with single circuit trac only. Color codes: P, MB

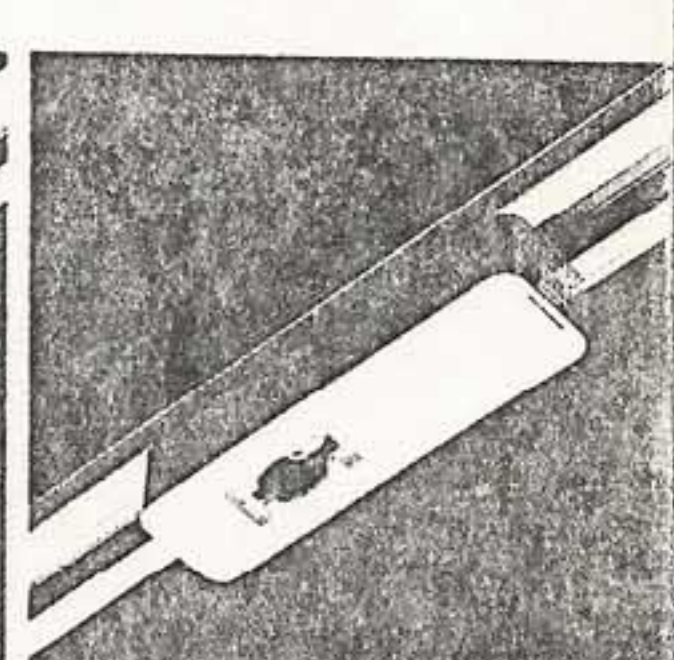

L2001—Solid State Adapter. For use with L2716, L2761, L2510, L2736, L2760 and L2765 lampholders. Other lampholders will not function if they are inserted into L2001 Adapter. For use with single circuit trac only. Color codes: P, MB

4 500 WATT 6" PRESNELS

4 500 WATT 6X9 LEXOS

(ELLIPSOIDAL SPOTLIGHTS)

BITS FOR LIGHTING

Chaser ON ? C

Chase Left ? D

Chase Right ? E

STARS

STARS

FLAG ()

ANALYSIS OF NEW ATTRACTION POTENTIAL

Licensed Character

STRATEGY	<ul style="list-style-type: none">• Improves the adult experience.• Maintains or improves the child experience.• Does not diminish the restaurant perception.• Offers new or novel form of entertainment.	<p>Yes</p> <p>Yes</p> <p>Yes</p> <p>Yes</p>
★ ★ ★ ★ ★ ★ ★ ★ ★ ★ NEW ENTERTAINMENT ATTRACTION ★ ★ ★ ★ ★ ★ ★ ★ ★ ★	<ul style="list-style-type: none">• Are development costs required? How long? - How much?• Can it be cost effectively adapted to locations?• What is the time frame for field testing?• What is the time frame for rollout?• Are special installation skills required?• What are anticipated maintenance costs?• What are software support costs?• What is projected R.O.I. ?• What will its' life be after 100% R.O.I.?	<p>Yes</p> <p>1 yr.</p> <p>No</p> <p>Same as Current</p> <p>Same as Current</p>
TIME & COST FACTORS		



April 2, 1987

This letter will serve as an agreement between ShowBiz Pizza Time, Inc., 4441 W. Airport Frwy., Irving, TX 75062 and Creative Presentations, Inc., 819 W. Lunt Ave., Schaumburg, IL 60193. Whereby Creative Presentations shall design and fabricate three (3) conversion kits to transform three (3) existing Rolfe characters, and 3 existing Looney Bird characters into three (3) sets of the Hanna-Barbera licensed characters of Yogi Bear and Boo Boo respectively, and their accompanying set and prop pieces as described below.

Under this agreement Creative Presentations will furnish the following:

1. Three (3) kits to transform Rolfe to Yogi Bear. These kits will each contain:
 - (A) A new Yogi Bear cosmetic head, complete with eyes, left and right, mouth movements, head left and right, and head up and down.
 - (B) A new Yogi Bear mechanical right arm and hand, to replace the arm and hand previously required for Earle.
 - (C) A new Yogi Bear cosmetic left hand.
 - (D) A fur body suit done inn Yogi Bear style, including feet.
 - (E) A Yogi Bear costume, consisting of hat, collar and tie.
2. Three kits to transform Looney Bird into Boo Boo. Each Kit will include:
 - (A) A new Boo Boo cosmetic head, including a new jaw plate to conform to Boo Boo's head configurations. All other movements existing in Looney Bird's head will be maintained except eye blink.
 - (B) A fur body suit to fit over the shoulders and upper body of the mechanism.
 - (C) A Boo Boo costume, i.e. bow tie.

Licensed Character Agreement (cont.)

Page 2

April 2, 1987

3. Three kits to transform an existing ShowBiz stage into Yogi's habitat. Each kit will include:
 - (A) A large "Jellystone Park" rustic sign approximately seven (7) feet in length to hang overhead.
 - (B) A large picnic basket.
 - (C) A decal or sign for Boo Boo's barrel which says "KEEP YOUR PARK CLEAN".
 - (D) A picnic table (max. size 3' x 4'), stump or large boulder on which to set the picnic basket.
4. Each kit shall also include step by step written instructions on converting Rolfe to Yogi and Looney Bird to Boo Boo.

The cost for these three (3) conversion kits will not exceed \$45,000.00 payable as follows:

\$22,500.00-Will be payable upon both parties signing this agreement.

\$22,500.00-Will be payable upon completion of the kits and upon approval by ShowBiz Pizza Time, Inc. and Taft Merchandising Group, Inc.

Enclosed you will find information regarding sources for props.

Target date for completion of the first set is May 14, 1987. The target date for the other two sets to be completed by June 15, 1987, and delivered to locations designated by ShowBiz by June 31, 1987.

Licensed Character Agreement (cont.)

Page 3

April 2, 1987

We are looking forward to you bringing Yogi and Boo Boo to
life on our stage,

Sincerely,

R. Stanton Black
Vice President
Director of Technical Services

CREATIVE PRESENTATIONS, INC.

DATE

SHOWBIZ PIZZA TIME, INC.

DATE

Pantone Matching System (PMS) Code

THE YOGI BEAR SHOW

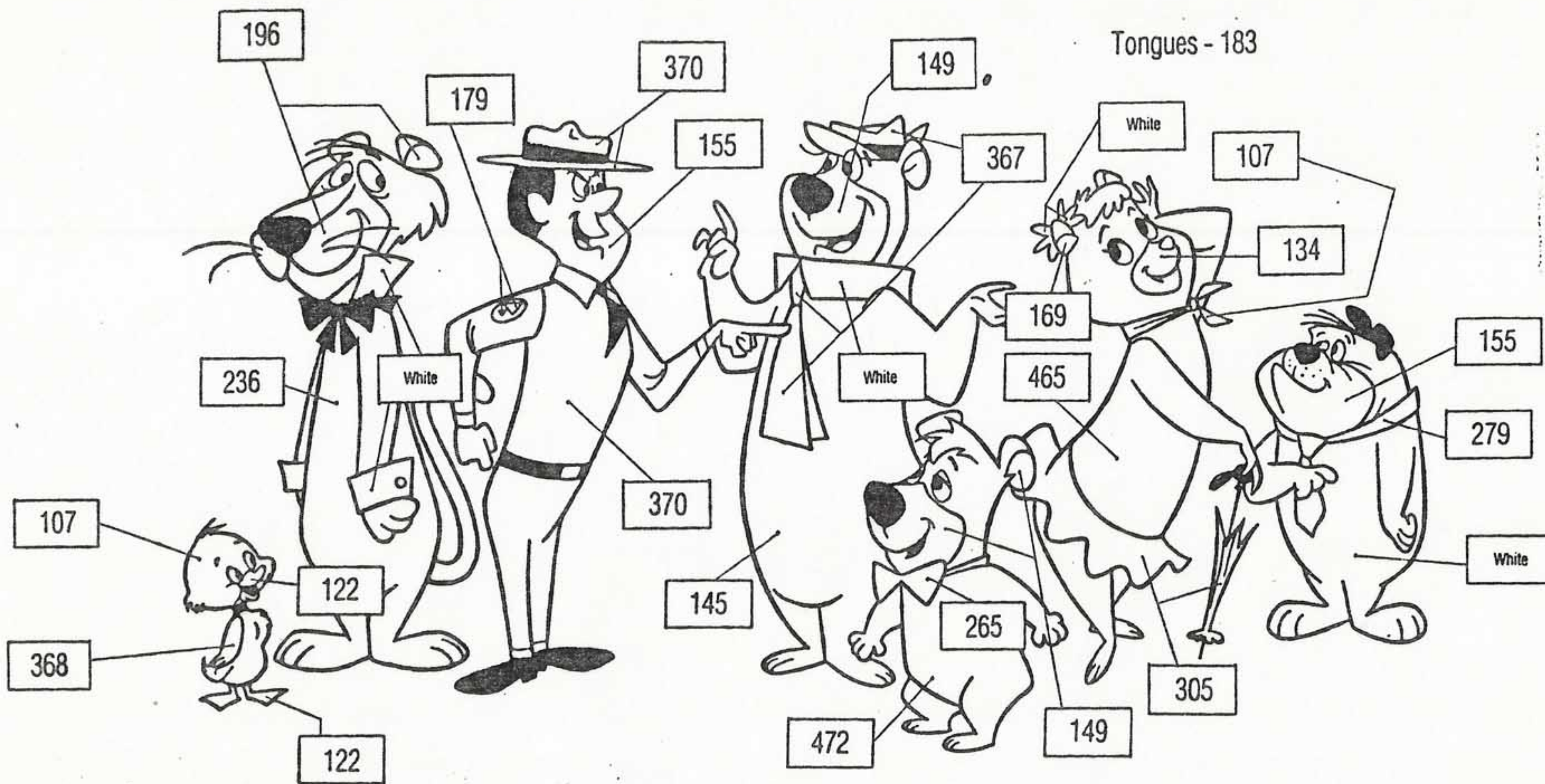

Yogi Bear



©1980
Hanna-Barbera
Productions, Inc.

original

Yogi Bears
© Hanna-Barbura
Productions, Inc.
1980

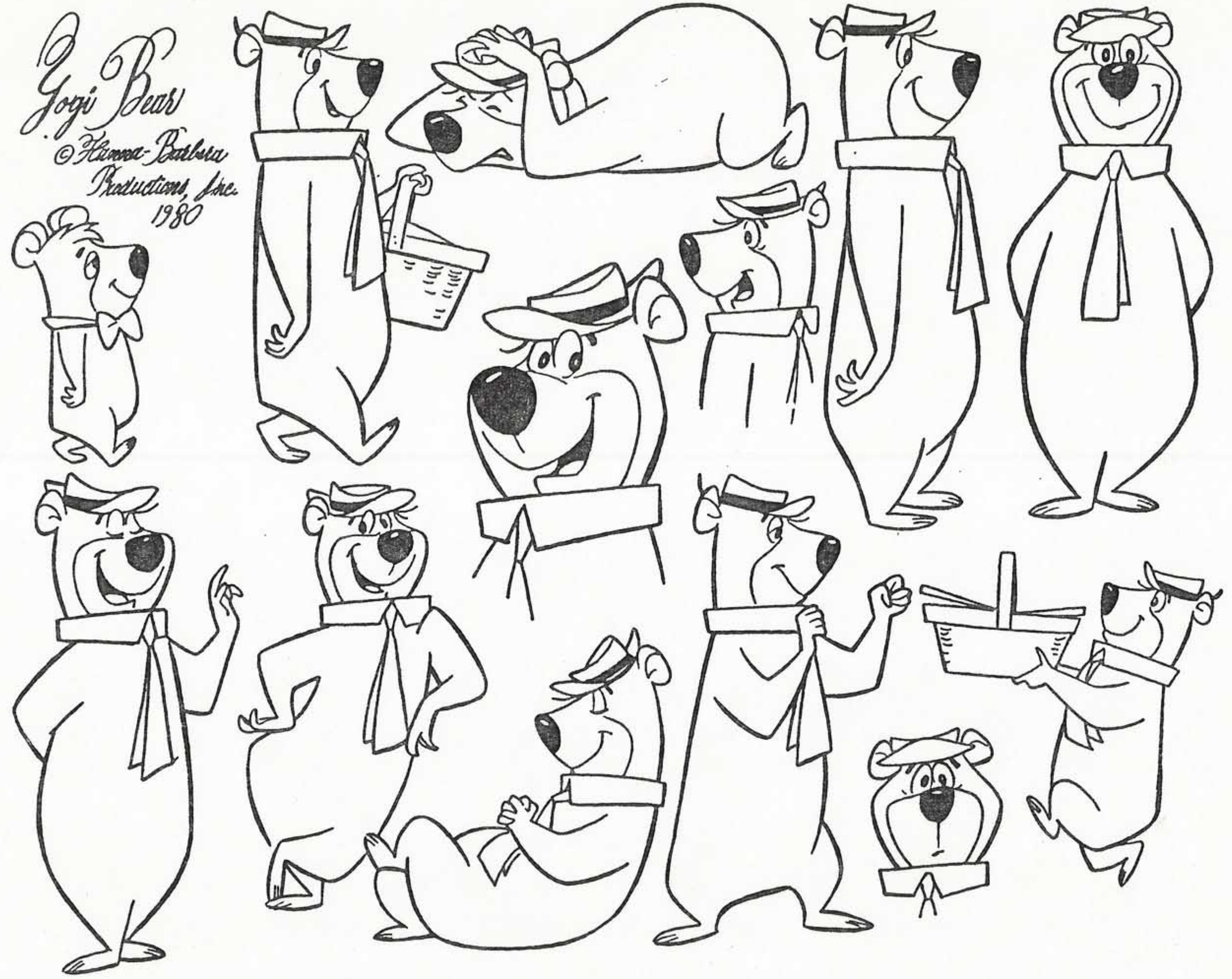

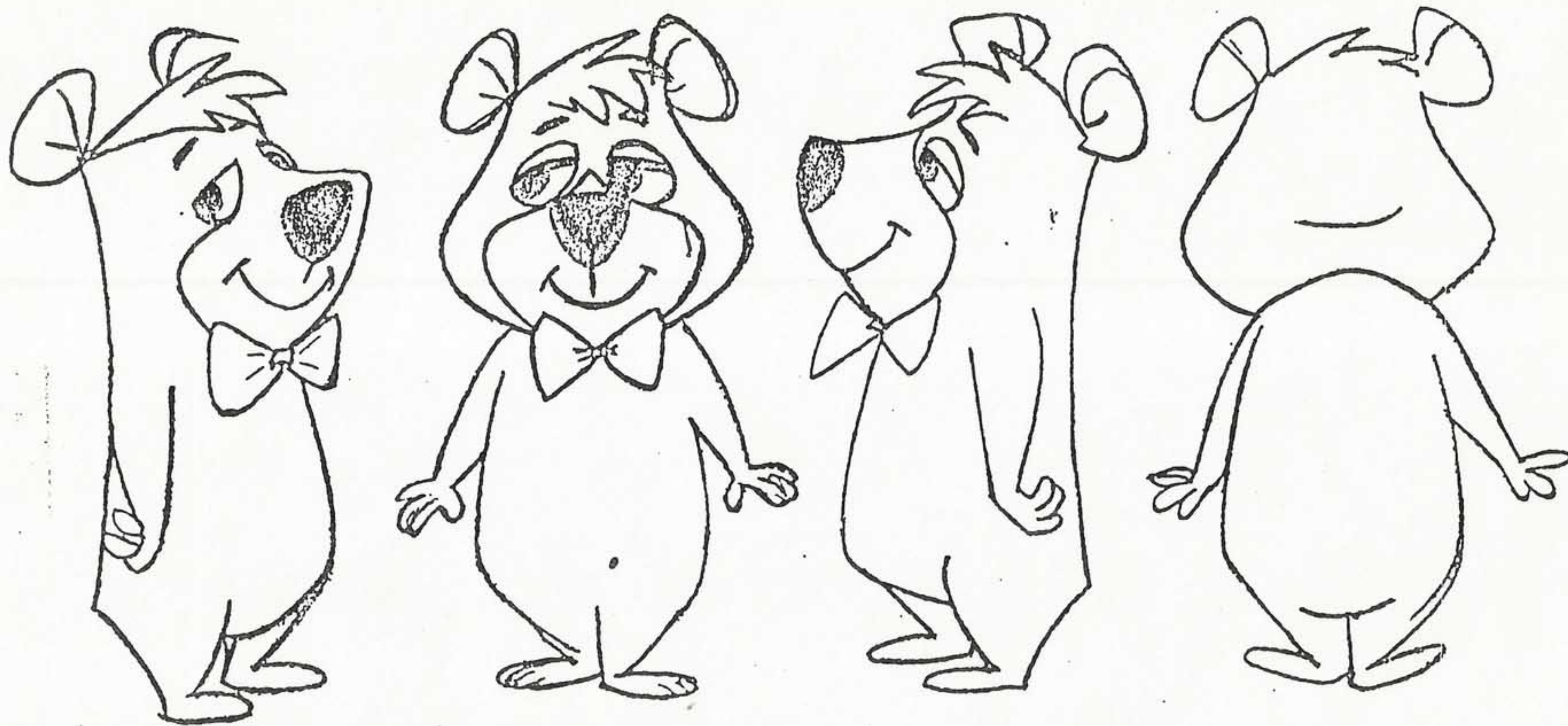

Boo Boo

Option #1

Move Mitzi to stage left with Billy Bob

Move Looney Bird to stage right with Rolf and Earl

Rearrange Fats, Duke and Beach Bear to different locations
Center Stage

Center Stage - Fats becomes old Orangutan
Duke becomes Chimpanzee
Beach Bear becomes Ape

Stage Left - Billy Bob becomes short, fat Hillbilly Bear
Mitzi becomes tall, skinny Hillbilly Bear

Stage Right - Rolf becomes old rabbit magician holding top
hat. (a false arm would be built to cradle top
hat. Rolf's real arm is inside hat)

Earl becomes small rabbit who pecks out of
top hat.

Looney Bird becomes a heckler rabbit who pops
up out of a giant top hat. (Rolf's left arm
would swing as if to hit the Heckler Rabbit who
always manages to duck in time)

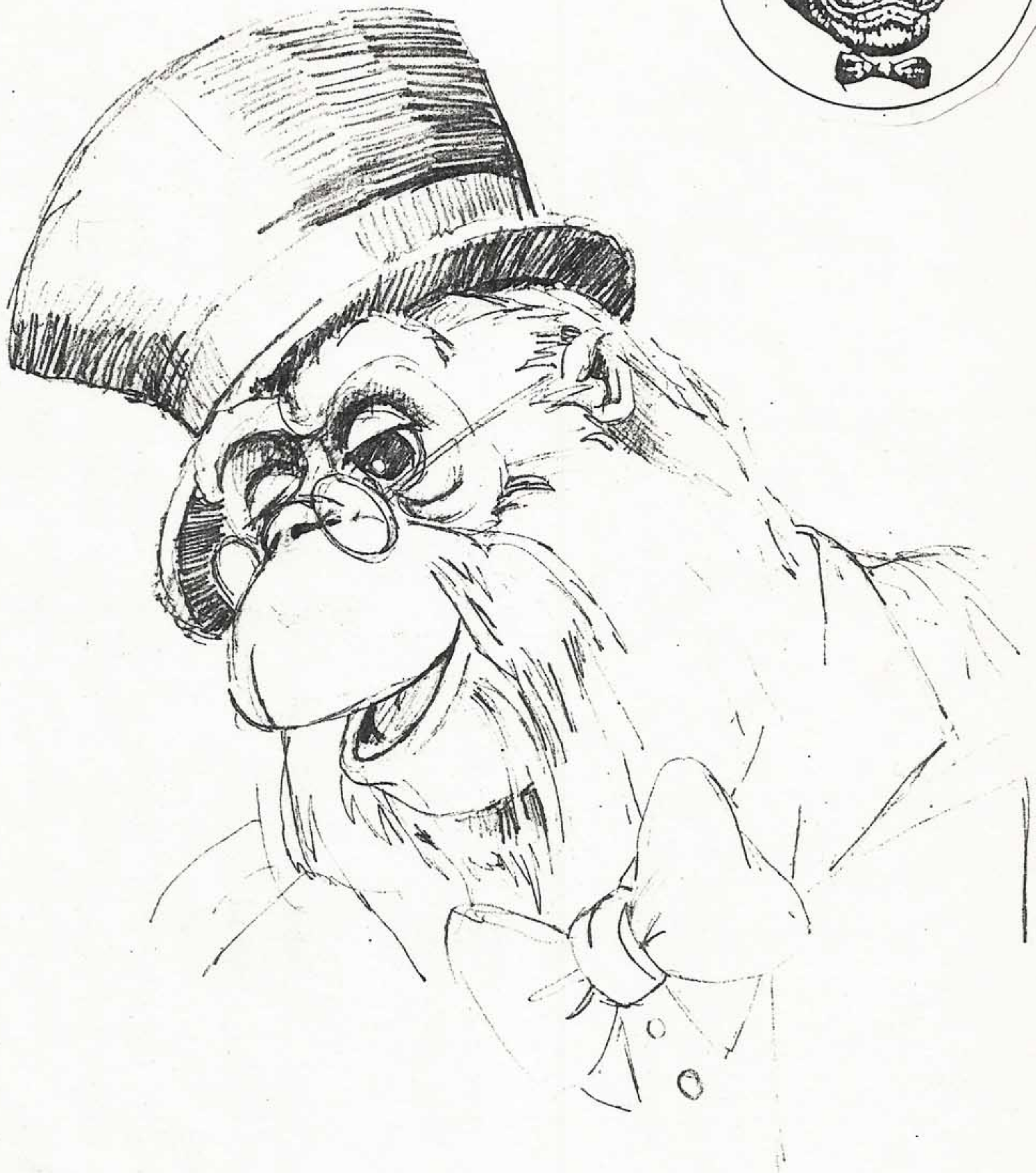
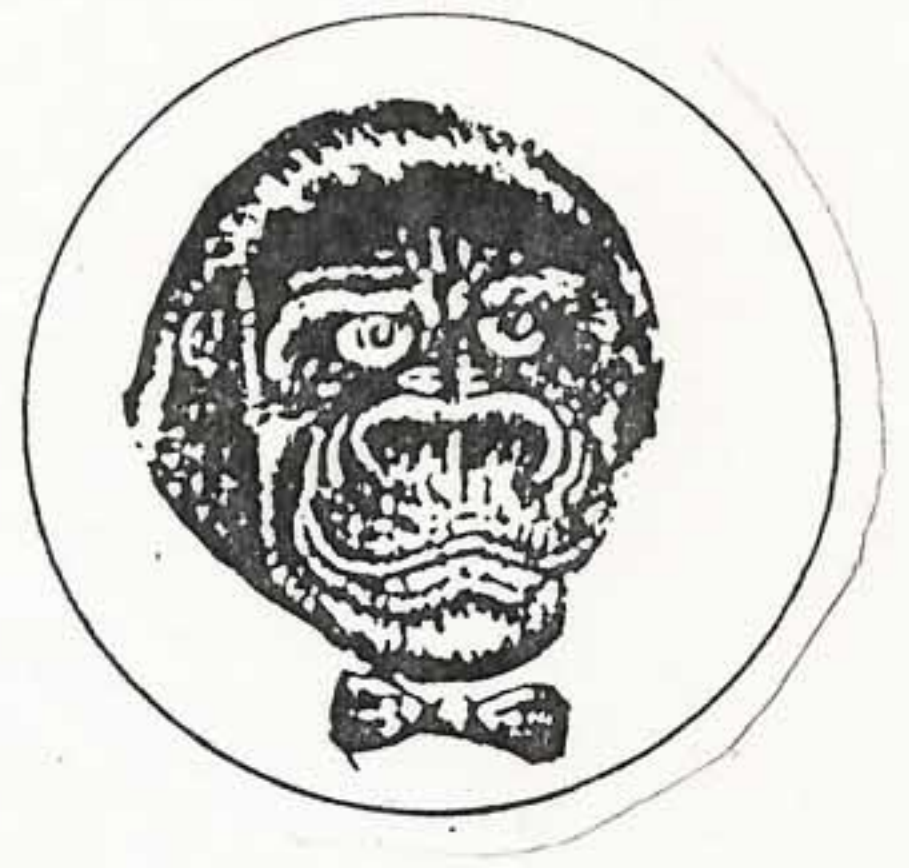







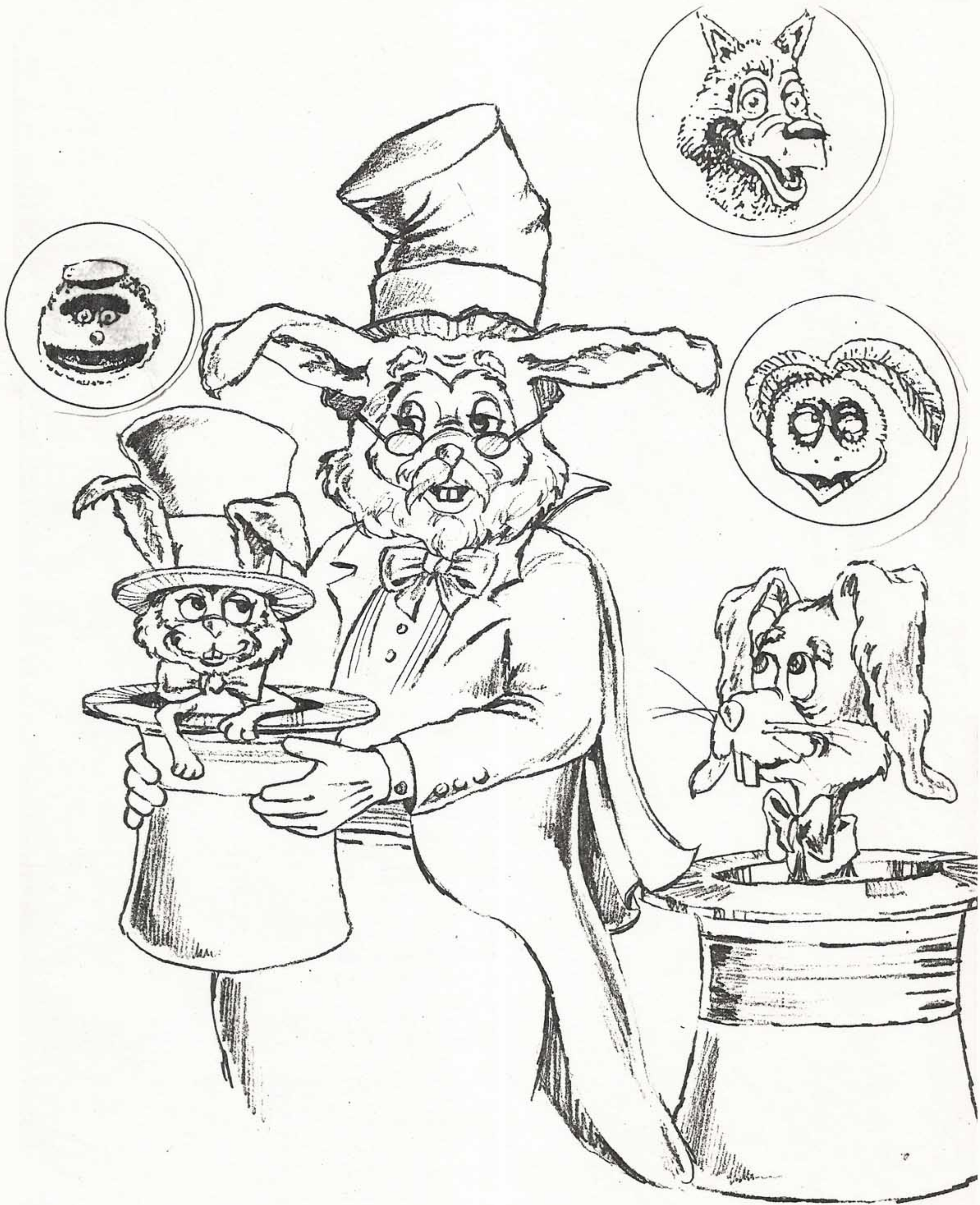

Option #2

All characters would remain on their same respective stages
(locations on the stage could be changed if needed)

Center Stage - Fats becomes a big, ugly Bear
Duke becomes Bob Cat Drummer
Beach Bear becomes a big, bird (Rooster)
Mitzi becomes a cute fox

Stage Left - Billy Bob becomes Lion
Looney Bird becomes a Rabbit in a top hat

Stage Right - Rolf becomes a comic female sheep.

A false arm is built for the sheep so that it
appears she is holding a puppet

Earl becomes a fox puppet













Option #3

All characters remain on their same respective stages
(locations on the stage could be changed if needed)

Center Stage - Fats becomes a Lion
Duke becomes a Leopard
Beach Bear becomes a Tiger
Mitzi becomes a pretty Cat

(Band is known as the "Wild Cats")

Stage Left - Billy Bob becomes a Safari Dog
Looney Bird becomes a small scroungy wolf
hound dog (his pet)

Stage Right - Rolf becomes an Alligator. A false hand is
fabricated to hold a fish bowl. Rolf's real
hand goes inside bowl.

Earl becomes a fish in the bowl



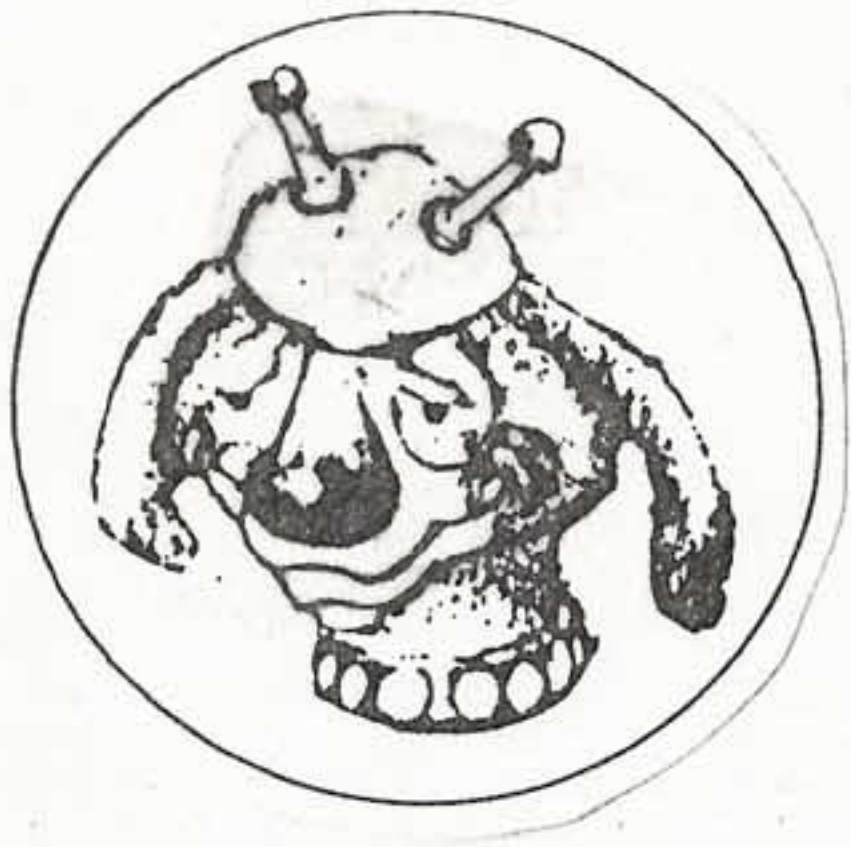









Option #4

This option would capitalize on the ShowBiz license of Yogi Bear characters. Fats and Mitzi would be moved to stage left. Billy Bob would go to center stage and Looney Bird would be moved to stage right.

Center Stage - Billy Bob would become Yogi Bear
Duke would become Boo Boo
Beach Bear would become Snaggle Puss

Stage Left - Fats would become a big, ugly bear
Mitzi would become a pretty fox

Stage Right - Rolf becomes an old rabbit magician holding top hat.
(a false arm would be built to cradle top hat. Rolf's real arm is inside hat)

Earl becomes a small rabbit who peeks out of top hat

Looney Bird becomes a heckler rabbit who pops up out of a giant top hat. (Rolf's left arm would swing as if to hit the Heckler Rabbit who always manages to duck just in time)









Creative Presentations Inc.

819 w. lunt ave., schauburg, illinois 60193-4481

fax no. (312) 894-8009

(312) 894-2248

September 21, 1987

Ms. Jul Kamen
ShowBiz Pizza Time, Inc.
4441 Airport Frwy.
Irving TX 75062

Dear Jul:

The following are estimates on costs for the various items you have requested.

Talking Flowers \$1900.00

New Mechanics & Cosmetics

Chuck E. Cheese	Full Body	\$10,095.00
Jasper	Full Body	\$ 9,915.00
Helen	Full Body	\$10,463.00
Munch	1/2 Body	\$ 9,422.00
Pasqually	1/2 Body	\$ 9,821.00
Warblettes	1/2 Body	\$ 2,553.00
Drum Board (4 moves)		\$ 2,706.00
Applause Board		\$ 4,043.00

49,716.

Curtains for House (2 sets of 2 Curtains) \$ 50.00

← Sculpt & Mold of 6 new faces (Design not Included) \$ 6,000.00 each

Price Per mask of new faces \$ 230.00 each

New Costumes (Design Not Included)

Dook - Full Costume	\$ 530.00
Fatz - Jacket	\$ 650.00
Rolfe - Upper Body Costume	\$ 300.00
Mitzi - Full Costume	\$ 500.00
Beach Bear - Lower Body Costume	\$ 120.00
Billy Bob - Pants	\$ 200.00

Ms. Jul Kamen
Page 2
September 21, 1987

We would recommend that instead of just replacing articles of clothing, as you have outlined above is that we design entirely new costumes. For instance the Billy Bob figure may have both jacket and pants, so it is a complete change.

Sincerely,

CREATIVE PRESENTATIONS, INC.

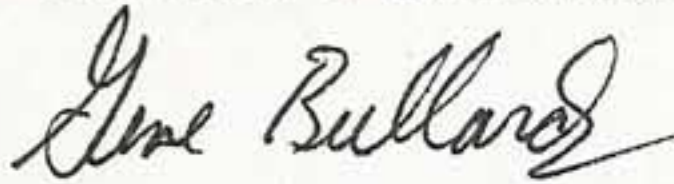
A handwritten signature in cursive script that reads "Gene Bullard". The signature is written in dark ink and is positioned above the typed name and title.

Gene Bullard
President

GB/cj

OCTOBER 23, 1986

GENE CRAMON
SHOWBIZ PIZZA PLACE INC.
4441 W. AIRPORT FREEWAY
IRVING, TX 75062

DEAR MR. CRAMON:

THANKS FOR YOUR INQUIRY INTO LA BELLE'S INFO SERIES OF ELECTRONIC PROGRAMMABLE SIGNS. SHOULD YOU EVENTUALLY BECOME A LA BELLE CUSTOMER, I WANT YOU TO KNOW THAT YOU'LL BE AMONG HUNDREDS OF SATISFIED COMPANIES, BIG AND SMALL, THAT IT HAS BEEN OUR PLEASURE TO SERVE OVER THE PAST 40 YEARS.

PLEASE EXAMINE THE ENCLOSED MATERIALS. THEY HAVE BEEN INCLUDED TO POINT OUT SOME OF THE FEATURES OF THE INFO SERIES SIGNS, AS WELL AS THE SELECTION OF MODELS FOR DIFFERENT AREAS OF APPLICATION.

AS A LA BELLE REGIONAL SALES MANAGER, I'LL BE HAPPY TO DEMONSTRATE ANY OR ALL OF THE INFO SERIES SIGNS THAT PEAK YOUR INTEREST. MY JOB IS TO HELP YOU MAKE AN INFORMED DECISION ON PURCHASING ELECTRONIC PROGRAMMABLE SIGNS; AND, TO ASSIST YOU IN ANY WAY I CAN. I LOOK FORWARD TO MEETING YOU SOON.

VERY TRULY YOURS,

LA BELLE INDUSTRIES, INC.

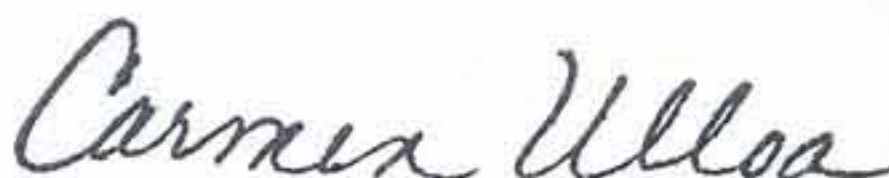
A handwritten signature in cursive script that reads "Carmen Ulloa".

CARMEN ULLOA
REGIONAL SALES MANAGER

ENCL.



 **Info Series**

102 LA

152 LA

202 LA

**Electronic
Programmable
Displays**



La Belle 

40 Years of Quality Products

La Belle Info Series - 102, 152, & 202 LA

The INFO Family of Programmable Displays comes in three (3) different sizes; 10, 15, or 20 characters of display, which allows you to choose the exact size that meets your requirements. INFO displays are the perfect communication tool for any number of uses from; welcoming guests, to advising customers of special sales or promotions, to providing informational messages such as meeting room locations or current interest rates. All INFO units feature brilliant 2" high LED displays that provide wide angle readability at distances of up to 60 feet. The attractively styled displays are enclosed in a sturdy brushed aluminum frame, inlaid with wood grain vinyl to compliment any location.

SPECIFICATIONS

	MODEL INFO 102 LA	MODEL INFO 152 LA	MODEL INFO 202 LA
Overall Dimension:	20 ³ / ₈ "L x 5 ¹ / ₈ "H x 2 ³ / ₄ "D	29 ³ / ₄ "L x 5 ¹ / ₈ "H x 2 ³ / ₄ "D	38 ³ / ₄ "L x 5 ¹ / ₈ "H x 2 ³ / ₄ "D
Weight:	9 Lbs.	12 Lbs.	15 Lbs.
Characters:	10	15	20

SPECIFIED FOR ALL INFO MODELS:

Display:	2" High LED
Display Modes:	21 (See Back Page)
Memory:	Over 7,600 Characters With Five (5) Separate Message Banks
Programming:	Fully User Programmable With Editing Functions
Graphics:	Ten (10) Standard Graphics Built In (Custom Graphics Available)
Programmer:	Detachable With Typewriter Format Keyboard
Power Source:	Detachable Low Voltage With Power Loss Memory Retention (48 hrs.)
Warranty:	One (1) Year Limited Warranty With Toll Free Service Number



UL approved power supply plugs into any standard 120V receptacle.



Typewriter format keyboard - - quick and simple message programming.



Pop-up mounting ears for ceiling suspension.

ACCESSORIES

All INFO Models:	25 Ft. Keypad Extension Cord D. C. Power Cord (For 12V Systems)
-------------------------	--

OPTIONS

All INFO Models:	Serial Port with RS232 and RS485 Capabilities
-------------------------	---



Serial interface option for versatile message programming.

La Belle 

U.S. • 510 S. WORTHINGTON, OCONOMOWOC, WI 53066 • 414-567-9101 • TOLL FREE 1-800-558-9526
CANADA • 85 CURLEW DRIVE, DON MILLS, ONT. M3A2P8 • 416-445-2556 • TOLL FREE 1-800-387-0204

LA Models

Although well suited for counter top placement, INFO displays are equipped with pop-up mounting ears for ceiling suspension. INFO displays can store up to 1,600 characters of programmed message memory in five (5) separate instantly recallable message banks and feature a detachable typewriter format keyboard for quick, simple message programming.



INFO MODEL 102 LA - 10 Character Programmable Display

DIMENSIONS

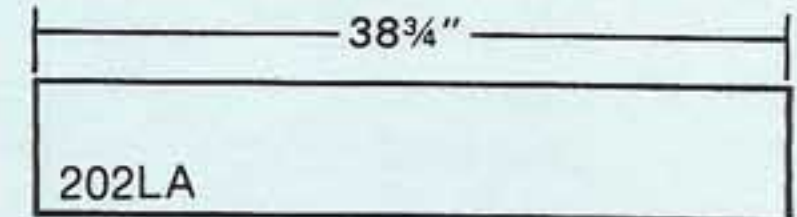
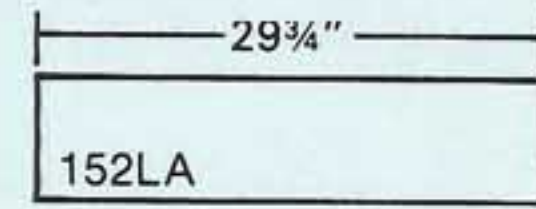
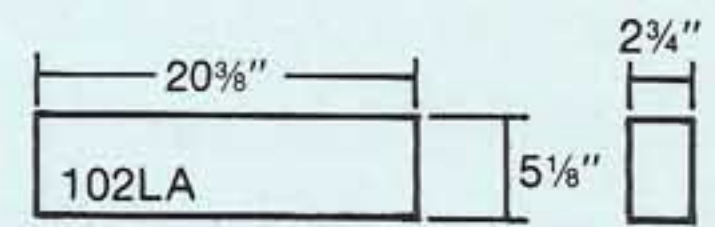

INFO MODEL 152 LA - 15 Character Programmable Display



INFO MODEL 202 LA - 20 Character Programmable Display

Info Display Modes & Functions

All INFO displays are simple to program and operate. Users will develop unique, effective messages in no time using the typewriter format programming keyboard. The keyboard also has 21 separate display options, ten (10) graphic characters, plus an editing mode to help you create dramatic eye-catching messages. Programmed messages can be recalled instantly with the touch of a key.

Built-in Graphics:

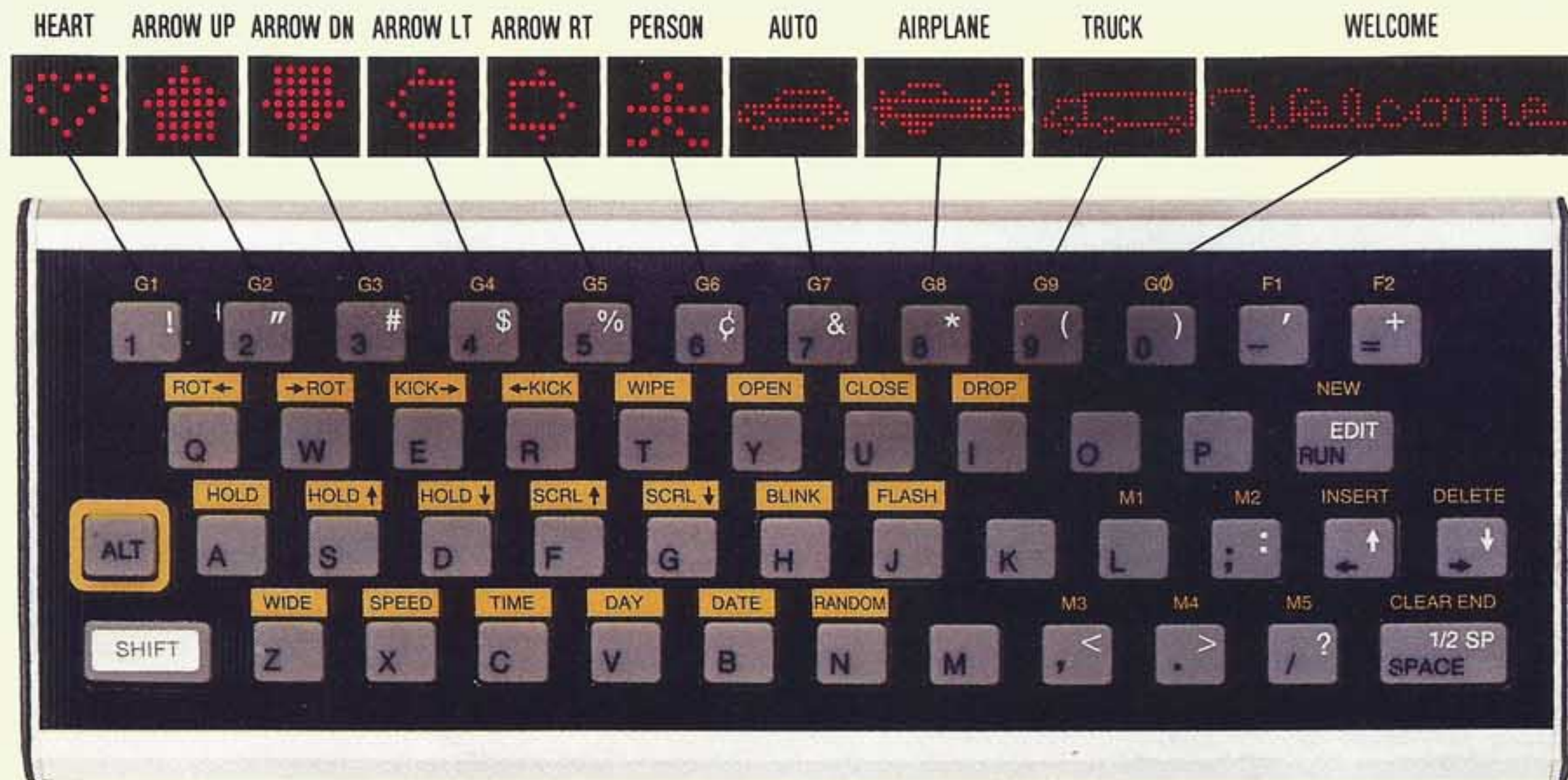

- | | | | |
|---------------|--|---------------|---|
| ROT ← | Rotate Left. Message will rotate from right to left across screen. | SCRL ↑ | Scroll Up. Message scrolls up from the bottom pushing the preceding message off screen. |
| → ROT | Rotate Right. Message will rotate from left to right across screen. | SCRL ↓ | Scroll Down. Message scrolls down from the top pushing the preceding message off screen. |
| KICK → | Kick Off. Message exits display to the right one character at a time. | BLINK | Blink. Message blinks on and off six times and then holds for one second. |
| ← KICK | Kick On. Message enters display from the right one character at a time. | FLASH | Flash. Message flashes with a reversed background three times, then holds for one second. |
| WIPE | Wipe. Message covers preceding message left to right. | RANDOM | Random. Message randomly appears one dot at a time as the preceding message disappears. |
| OPEN | Open. Message expands to the left and right from the center of the display. | WIDE | Wide. Displays characters at twice their normal width. |
| CLOSE | Close. Message collapses from the left and right into the center of the display. | TIME | Time. Displays hours and minutes; also AM/PM. |
| DROP | Drop. Preceding message drops down to reveal new message. | DAY | Day. Displays "Sunday" through "Saturday" alone, or within a given message. |
| HOLD | Hold. Message is stationary for three seconds. | DATE | Date. Displays month and day. |
| HOLD ↑ | Hold Up. Message is displayed for 1½ seconds, then moves up and off of the screen. | SPEED | Speed. Changes speed of other functions between normal and fast. |
| HOLD ↓ | Hold Down. Message is displayed for 1½ seconds, then moves down and off of the screen. | | |

This LaBelle slide projector, built in 1955, came back for maintenance after 30 years and was promptly serviced and returned. Quality and service have been a LaBelle tradition for over 40 years and we back it with a full one-year parts and workmanship warranty on all INFO displays.



La Belle 

40 Years of Quality

Info Series

102 LS
152 LS
1620 SA
2430 SA

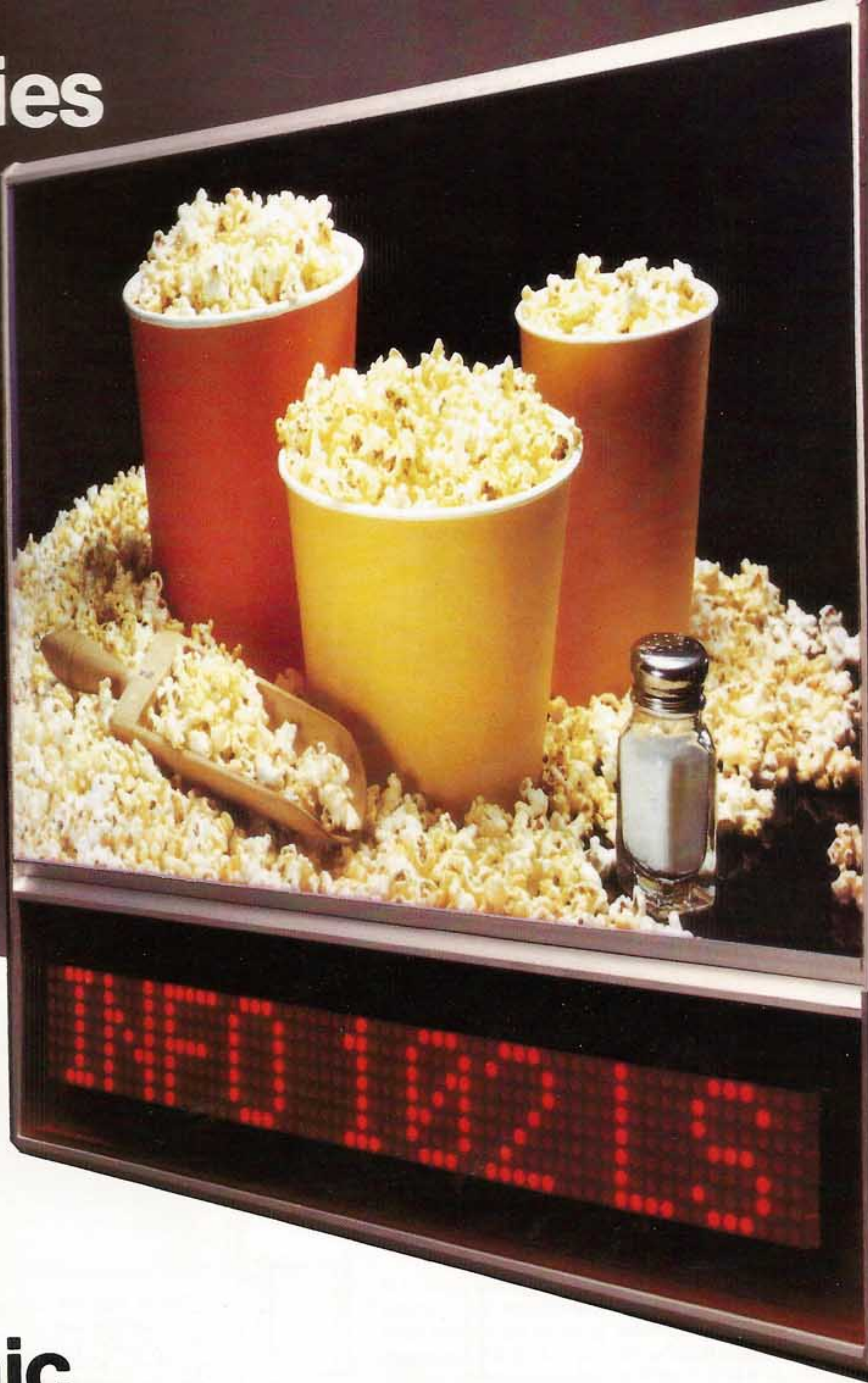

Electronic Programmable Displays

 **La Belle** 

40 YEARS OF QUALITY AND SERVICE

La Belle Info Series

Info 102 & 152 LS

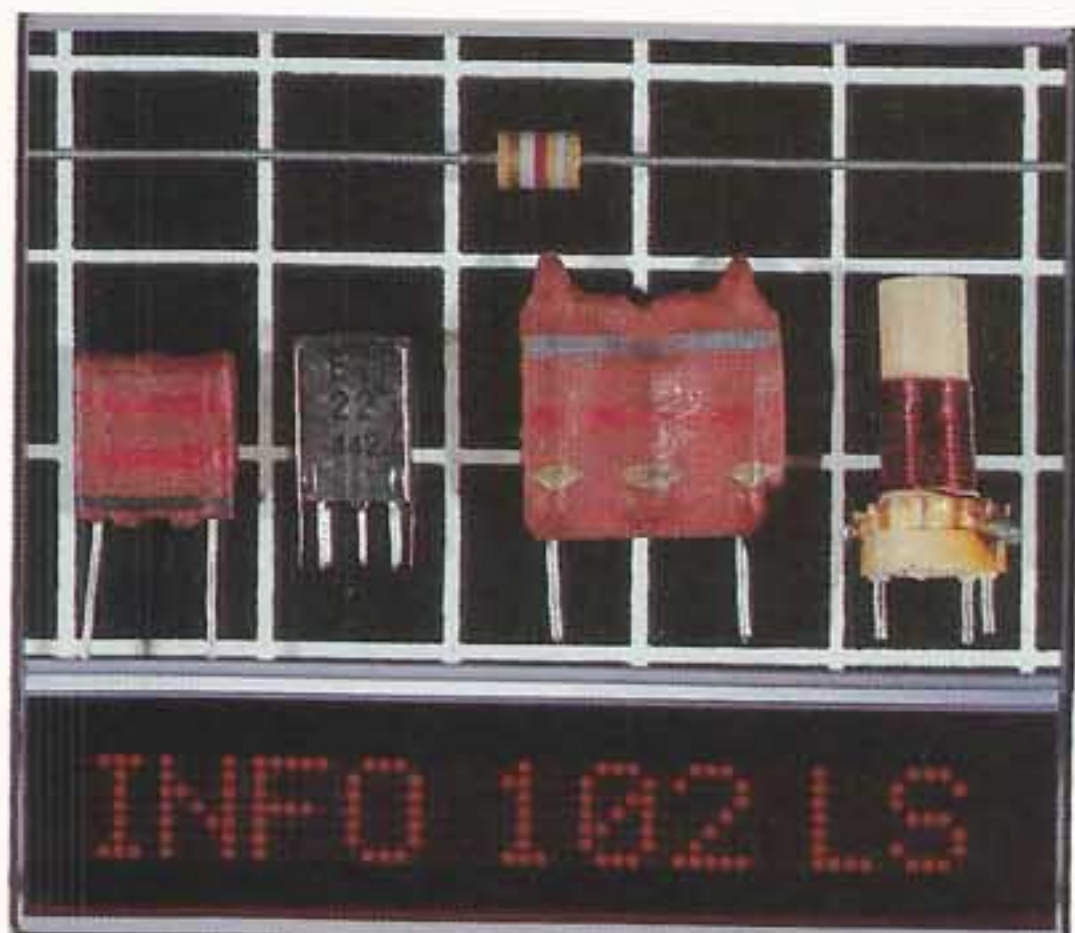

102 LS

Overall Dimension: 20-3/4"L x 18"H x 4 1/8"D
 Weight: 20 lbs.
 L.E.D. Characters: 10
 Display: 2" High Red L.E.D.
 Memory: 7600 characters with 5 separate memory banks, 48 hour power loss retention
 Programming: Detachable with Typewriter Format Keyboard with Editing
 Graphics: Ten (10) standard built-in (Custom available)
 Lighting: Two GE F15/T8 cool white fluorescent tubes
 Transparency Size: Length 20" (±.015") Height 12.25" (±.015")
 Warranty: One year limited warranty, toll free service number



152 LS

Overall Dimensions: 29 3/4"L x 24 3/8"H x 4 1/8"D
 Weight: 30 lbs.
 L.E.D. Characters: 15
 Display: 2" High Red L.E.D.
 Memory: 7600 characters with 5 separate memory banks, 48 hr. power loss retention
 Programming: Detachable typewriter format keyboard with editing
 Graphics: Ten (10) standard built-in (custom available)
 Lighting: Two GE F20/T8 cool white fluorescent tubes
 Transparency Size: Length: 29.375" (±.015)
 Height: 18.929" (±.015)
 Warranty: One year limited warranty; toll free service number

LaBelle presents the Info 102LS and the Info 152LS which combine the versatility of changeable L.E.D. messages with the beauty of backlit visuals for extra impact in virtually any setting. The backlit transparency housing provides brilliant, even lighting that gives any photo or artwork that added dimension of excitement. Together, a fully user-programmable L.E.D. message system and a backlit visual panel can silently "talk" to your customers or clients and dramatically increase their awareness of your products or services.

Designed tough and handsome, the Info LS series are built of solid aluminum with inlaid woodgrain vinyl. Special pop-up mounting ears make ceiling suspension a safe and simple proposition. Other mounting options include sturdy wall-hanging ports and stable countertop legs. It's easy to change transparencies without using tools. Just remove the pressure panel, slide out the old transparency and put the new one in.

Even first time users will find programming messages easy-and fun with LaBelle's typewriter format detachable keyboard. Bright, highly readable L.E.D. letters spell out your information in five separately recallable memory banks with 21 display modes and functions including built-in graphics. The editing mode allows you to modify or change existing messages without having to start over - a definite plus when time is of the essence. (For a complete listing of modes and functions, please refer to the back page).



Stable legs for countertop use.



Pop-up mounting ears for ceiling suspension.



Transparencies slide in and out - no tools needed.



Easy to use typewriter format keyboard.

La Belle Info Series Info 1620 & 2430 SA



1620 SA

Overall Dimensions: 20 $\frac{3}{8}$ "L x 16 $\frac{1}{2}$ "H x 4 $\frac{1}{8}$ "D
 Weight: 11 lbs.
 Lighting: Two GE F15/T8 white fluorescent tubes
 Transparency Size: Height 16" ($\pm .015$) Length 20" ($\pm .015$)
 Warranty: One year limited warranty, toll free service number



2430 SA

Overall Dimensions: 30 $\frac{3}{8}$ "L x 24 $\frac{3}{8}$ "H x 4 $\frac{1}{8}$ "D
 Weight: 18 lbs.
 Lighting: Two GE F20/T8 cool white fluorescent tubes
 Transparency Size: Height 24" ($\pm .015$) Length 30" ($\pm .015$)
 Warranty: One year limited warranty, toll free service number

To compliment the Info 102LS and the Info 152LS, we've created the Info 1620SA and the 2430SA light boxes. By giving particular attention to stylistic details, we are able to offer aesthetically pleasing options in combining the SA and LS series into system configurations that really make your products and services stand apart from the crowd.

Backlighting gives an added dimension of super realism and excitement to any photograph or artwork. Two easy-access fluorescent tubes provide brilliant, even lighting that brings out the best in your visuals. Constructed of strong, durable aluminum, the 1620SA and 2430SA are built to last a lifetime. Unique pop-up mounting ears provide reliable support for ceiling suspension in addition to strong wall mounting ports or sturdy countertop legs. Transparencies can be changed quickly and easily by removing the side pressure plate and sliding the new visual in, without the use of tools.

Used together with the Info LS signs, you can create dazzling displays of light and color that silently "talk" to your customers both visually and verbally about the beauty and benefits of your products and services. Your sign dealer will be happy to review the potential of using our system for a wide variety of applications including restaurant menu systems, trade shows and exhibits, lobby displays, and a host of other uses, limited only by the imagination.

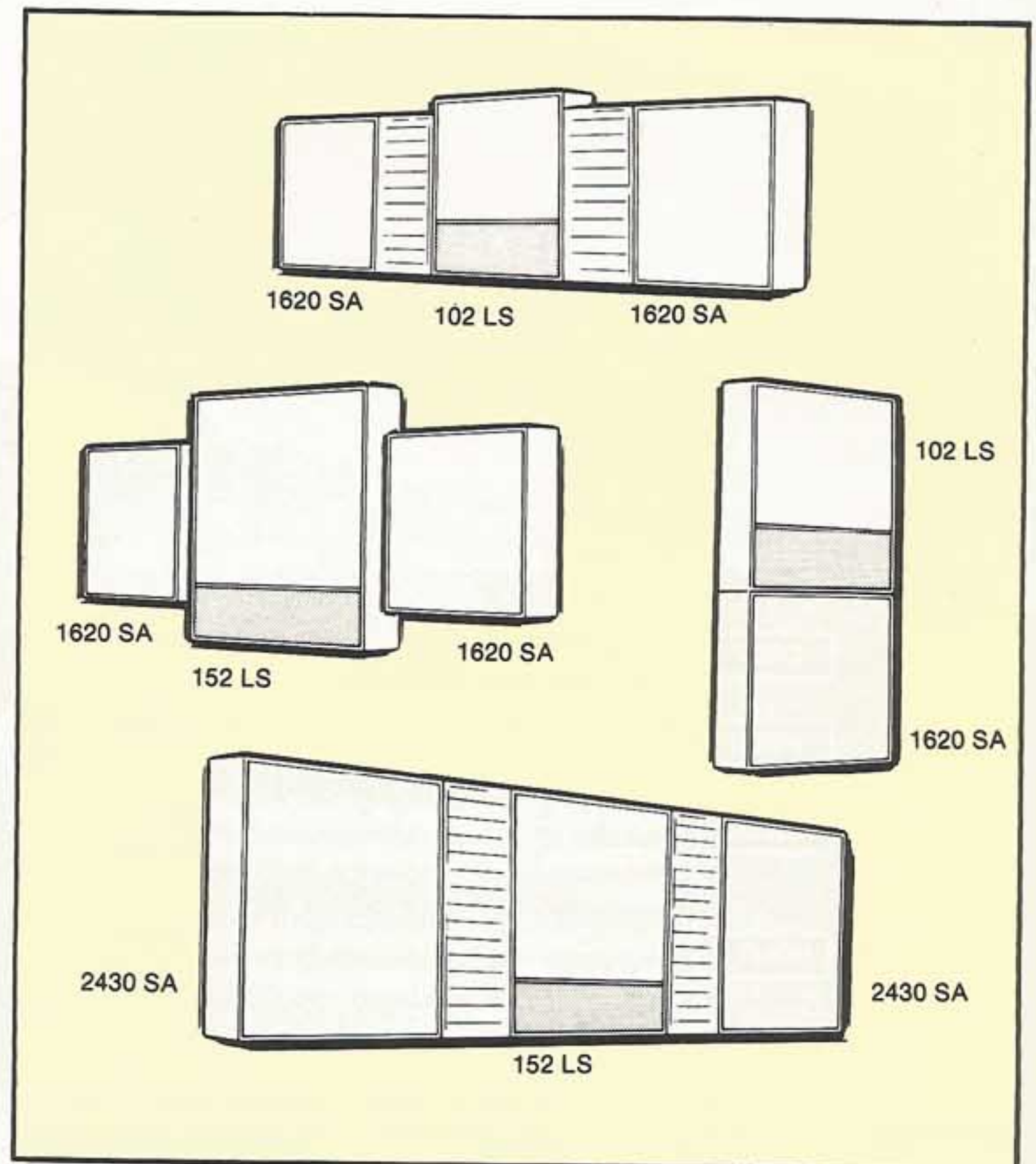

Info Display Modes & Functions

All INFO displays are simple to program and operate. Users will develop unique, effective messages in no time using the typewriter format programming keyboard. The keyboard also has 21 separate display options, ten (10) graphic characters, plus an editing mode to help you create dramatic eye-catching messages. Programmed messages can be recalled instantly with the touch of a key.

Built-in Graphics:

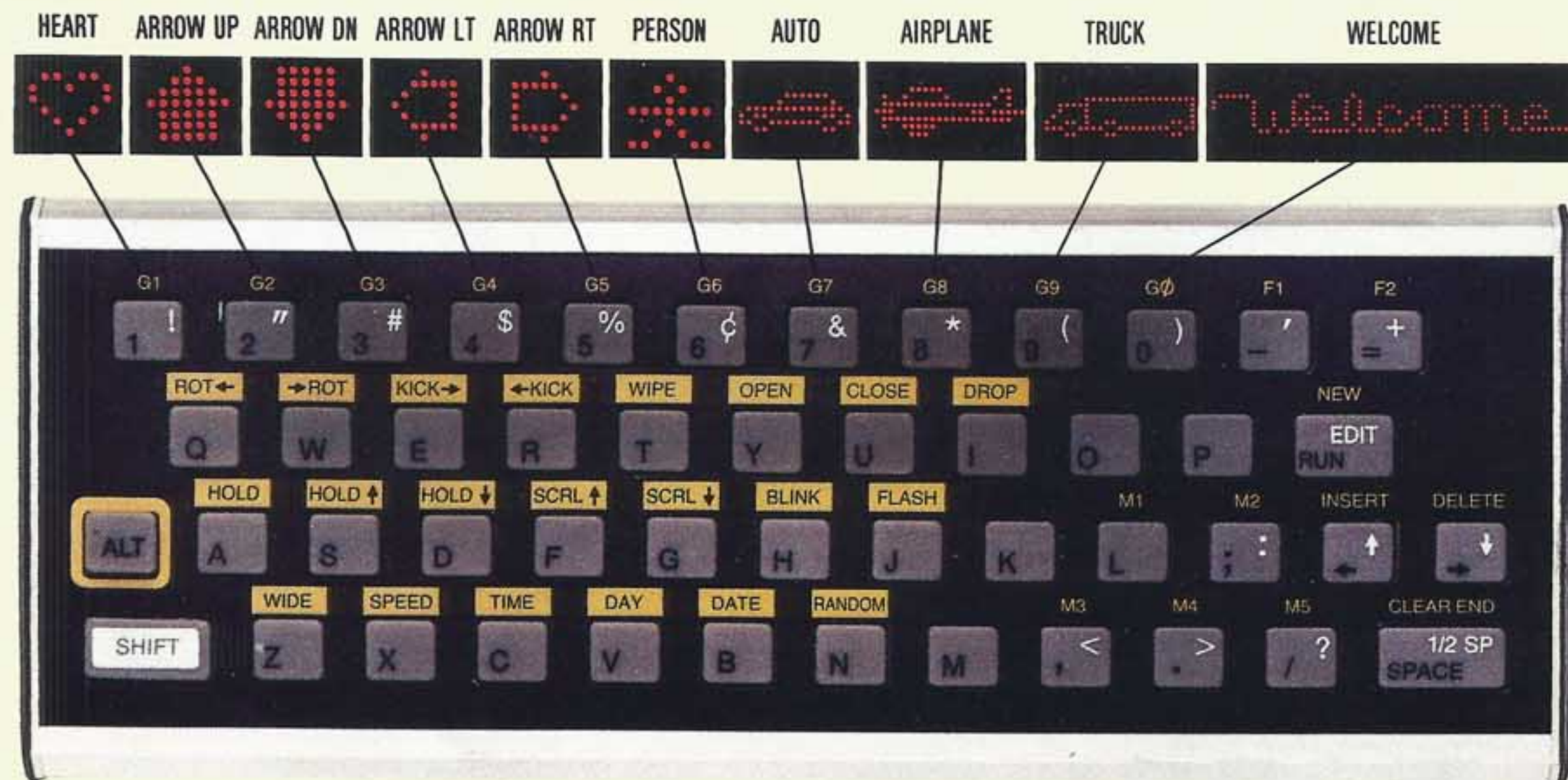

- ROT ←** Rotate Left. Message will rotate from right to left across screen.
- ROT** Rotate Right. Message will rotate from left to right across screen.
- KICK →** Kick Off. Message exits display to the right one character at a time.
- ← KICK** Kick On. Message enters display from the right one character at a time.
- WIPE** Wipe. Message covers preceding message left to right.
- OPEN** Open. Message expands to the left and right from the center of the display.
- CLOSE** Close. Message collapses from the left and right into the center of the display.
- DROP** Drop. Preceding message drops down to reveal new message.
- HOLD** Hold. Message is stationary for three seconds.
- HOLD ↑** Hold Up. Message is displayed for 1½ seconds, then moves up and off of the screen.
- HOLD ↓** Hold Down. Message is displayed for 1½ seconds, then moves down and off of the screen.

- SCRL ↑** Scroll Up. Message scrolls up from the bottom pushing the preceding message off screen.
- SCRL ↓** Scroll Down. Message scrolls down from the top pushing the preceding message off screen.
- BLINK** Blink. Message blinks on and off six times and then holds for one second.
- FLASH** Flash. Message flashes with a reversed background three times, then holds for one second.
- RANDOM** Random. Message randomly appears one dot at a time as the preceding message disappears.
- WIDE** Wide. Displays characters at twice their normal width.
- TIME** Time. Displays hours and minutes; also AM/PM.
- DAY** Day. Displays "Sunday" through "Saturday" alone, or within a given message.
- DATE** Date. Displays month and day.
- SPEED** Speed. Changes speed of other functions between normal and fast.

This LaBelle slide projector, built in 1955, came back for maintenance after 30 years and was promptly serviced and returned. Quality and service have been a LaBelle tradition for over 40 years and we back it with a full one-year parts and workmanship warranty on all INFO displays.



La Belle 

40 Years of Quality

Twice as Nice.



The New Info 2152 LA Two-Liner.

Specifications

Overall Size:	29 3/4" L x 8" H x 3 3/8" D
Weight (appr.):	16 lbs.
Display:	2 lines, each 15 characters x 2" H
Display Modes:	21 (see below)
Memory:	7600 characters with 5 separate message banks
Programming:	Fully user programmable with editing functions
Graphics:	10 standard graphics built-in
Programmer:	Detachable with typewriter keyboard
Power Source:	120 Volt AC grounded plug
Warranty:	One (1) year limited warranty (toll free service number)

Display Modes/Functions

- Rotate Left
- Rotate Right
- Widen Characters
- 2 Speed Display
- Wipe
- Kick Left
- Kick Right
- Random Fade
- Hold
- Hold up
- Hold down
- Blink (Flash)
- Reverse Flash
- Scroll up
- Scroll down
- Drop
- Open
- Close
- Time
- Day
- Date

The long awaited La Belle INFO Series 2" by 2 line sign has finally arrived. Priced far below the competition, the 2152 LA is designed to perform two line functions for extra impact in any setting.

An LED matrix with powerful software, the 2152 stores up to 7600 characters in memory with 5 separate message banks that can be recalled with the touch of a key. Twenty-one modes and functions complete with time, day, date and 10 built-in graphics make your two line messages informative and entertaining.

Included with the 2152 LA is an easy-to-use typewriter format keyboard, a one year limited warranty, and the assurance of La Belle's 40 year tradition of quality manufacturing and customer service.

Made at our factory in the U.S., the 2152 LA is available in 10, 15 and 20 character lengths to fit any size and price needs. Call La Belle now to order your two line sign.

Info 2152 LA with easy to use typewriter keypad.



La Belle 

LA BELLE INDUSTRIES • 510 S.WORTHINGTON, OCONOMOWOC, WI 53066 • (414) 567-9101 • 1 (800) 558-9526
 LA BELLE CANADA • 85 CURLEW DRIVE, DON MILLS, ONT. M3A2P8 • (416) 445-2556 • 1 (800) 387-0204

Economy and Scale.

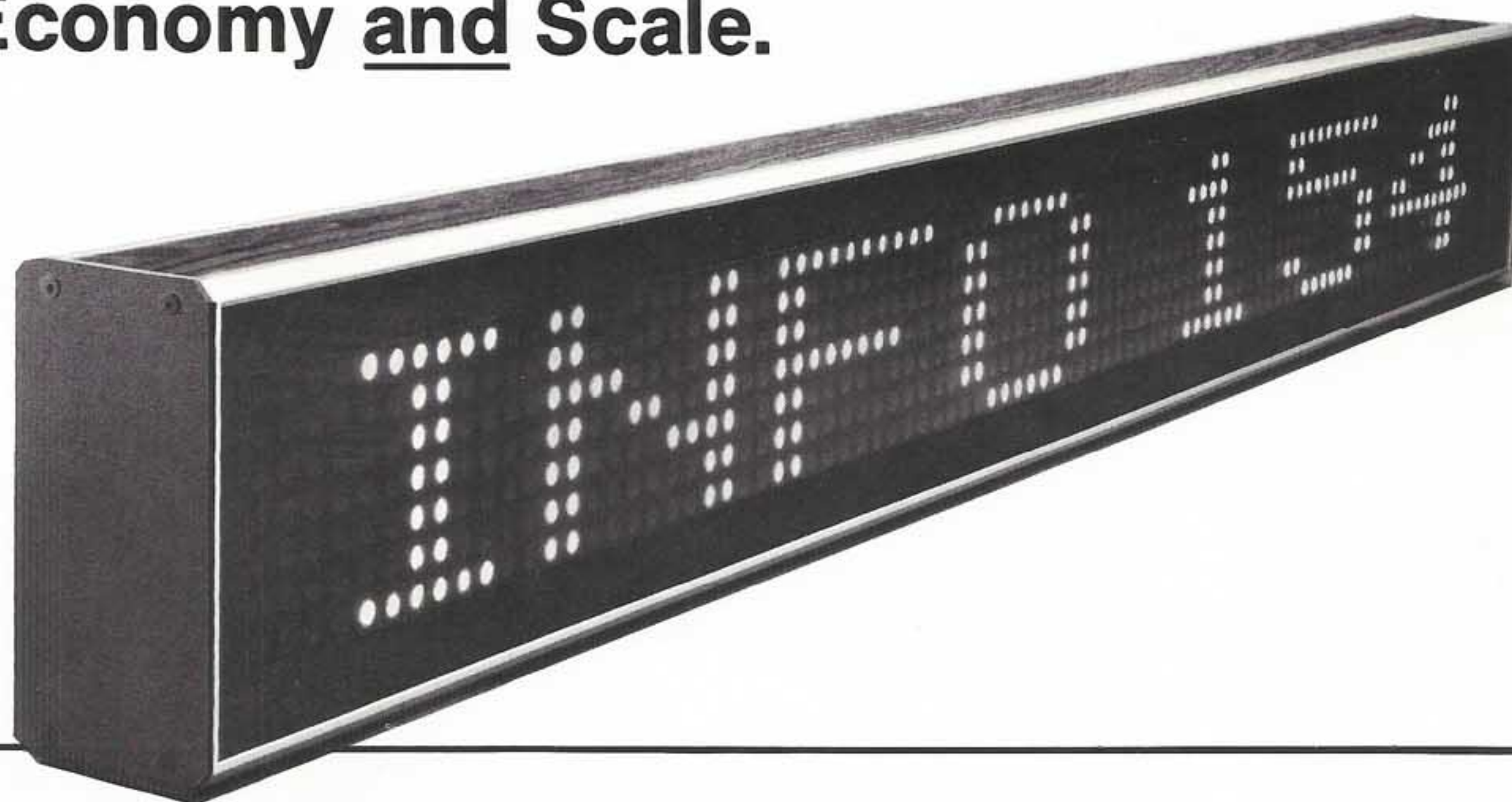

The New 4" La Belle Info 154 LA.

Specifications

Overall Size:	57½"L x 8"H x 3¾"D
Weight (appr.):	21 lbs.
Display:	15 characters x 4" high
Display Modes:	21 (see below)
Memory:	7600 characters with 5 separate message banks
Programming:	Fully user programmable with editing functions
Graphics:	10 standard graphics built-in
Programmer:	Detachable with typewriter keyboard
Power Source:	Low voltage with power loss memory retention
Warranty:	One (1) year limited warranty (toll free service number)

Display Modes/Functions

- | | | |
|--------------------|-----------------|---------------|
| • Rotate Left | • Random Fade | • Scroll down |
| • Rotate Right | • Hold | • Drop |
| • Widen Characters | • Hold up | • Open |
| • 2 Speed Display | • Hold down | • Close |
| • Wipe | • Blink (Flash) | • Time |
| • Kick Left | • Reverse Flash | • Day |
| • Kick Right | • Scroll up | • Date |

You get economy and scale with La Belle's new four-inch INFO series of electronic programmable displays. The INFO 104, 154 and 204 LA combine large LED dots into a proportioned matrix that makes for easy reading at distances over 200 feet. Available in 10, 15 and 20 character lengths, there's a size and price to fit any large programmable signage need.

Tough and handsome extruded aluminum encases some of the smartest software around. 7600 characters of memory in 5 separate message banks provide the capacity to store up to seven typewritten pages of information. Twenty-one modes and functions complete with time, day, date and 10 built-in graphics make INFO series messages informative and entertaining.

Programming is easy with La Belle's typewriter format keyboard. "Finger friendly" large keys make composing messages comfortable, while color coded commands make it easy to find what you're looking for. Even first time users will agree that programming the La Belle INFO series signs is quick and uncomplicated.

All INFO series signs are completely manufactured at our factory in Oconomowoc, Wisconsin under the strictest quality control conditions. Each sign is given a full one year parts and labor warranty along with the assurance of La Belle's 40 year tradition of quality manufacturing and customer service.

La Belle 

LA BELLE INDUSTRIES • 510 S.WORTHINGTON, OCONOMOWOC, WI 53066 • (414) 567-9101 • 1 (800) 558-9526
 LA BELLE CANADA • 85 CURLEW DRIVE, DON MILLS, ONT. M3A2P8 • (416) 445-2556 • 1 (800) 387-0204

Info Series

LT9

LT6

LT3



**Electronic
Programmable
Displays**

 **La Belle** 

40 Years of Quality Products

The LT9 features nine 8 x 10 transparency "windows", each individually lighted and programmable in conjunction with an LED matrix of 2" characters that appear above or below the picture matrix.

The LED portion of the Info LT9 has 21 exciting modes and functions including 10 built-in graphics and an internal calendar clock function. It features over 7000 characters of memory that will hold up to seven typewritten pages of information in five separate message banks.

The potential for such a complete communications package is exciting. You can tell an entire story much like an audio visual presentation or a video at a fraction of the cost. Simply program the LED with your message along with commands to the transparency matrix with the La Belle detachable typewriter format keyboard. Transparencies can easily be made from photographs or slides at any color lab listed in the La Belle transparency lab guide.

The Info LT9 is constructed of durable aluminum, and anodized with a high-tech black finish that compliments any setting. Styling and features on the LT9 allow it to be displayed on the wall, hung from above, on a countertop, or on its own attractive pedestal base.

The Info LT series is manufactured completely in the United States by La Belle Industries, a company with over 40 years of proven reliability and service in the visual communication industry. Call 1-800-558-9526 (in Canada 1-800-387-0204) for more information.

INFO LT SERIES SPECIFICATIONS

Overall Dimensions:	LT9-31"H x 29¾"L x 4½"D LT6-22¾"H x 29¾"L x 4½"D LT3-13½"H x 29¾"L x 4½"D
Weight:	LT9-45 lbs., LT6-35 lbs., LT3-25 lbs.
Display:	2" x 15 character Red LED. Reads correctly above or below picture matrix
Memory:	Over 7000 characters, 5 separate memory banks, 48 hour power loss memory retention
Graphics:	10 built-in LED graphics standard, (custom available)
Lighting:	GE 60 T-10/F showcase lamp for each transparency box
Transparency Size:	9-25/32"L x 8"H (each)
Warranty:	One year limited warranty with toll free service number

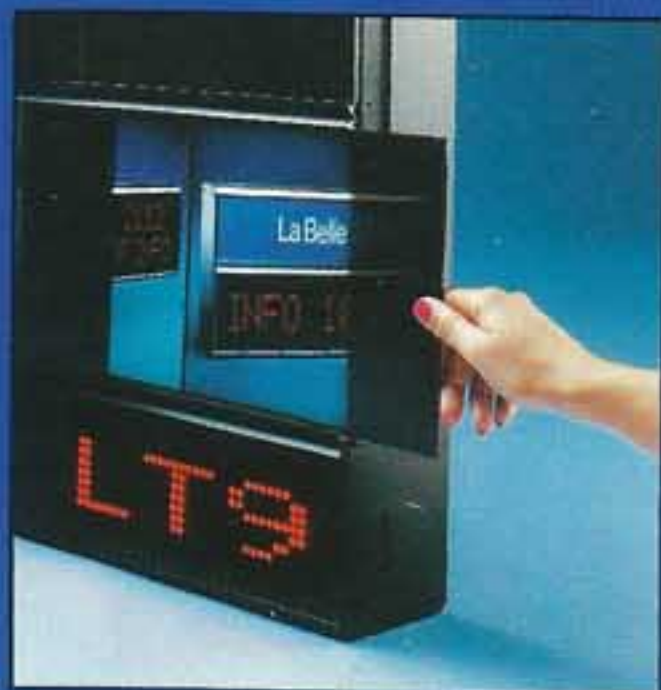

Transparencies slide easily in and out from either side.



Need your copy on top? Simply turn the LT sign upside-down, the readout compensates automatically!

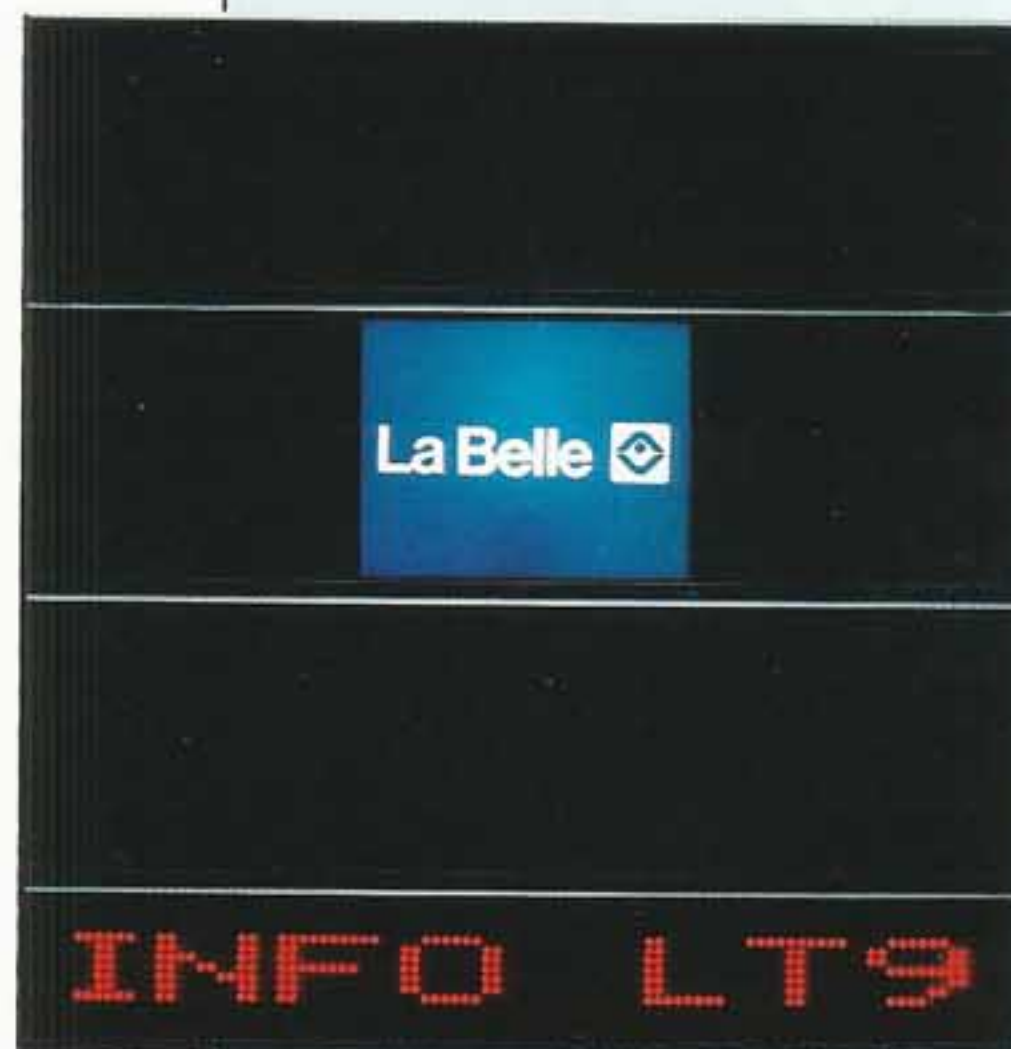

La Belle Info LT9: Nine transparency version.



La Belle Info LT6: Six transparency version.



La Belle Info LT3: Three transparency version.

Communications with a whole new meaning.



The picture matrix of the Info LT9 is individually lighted using inexpensive yet powerful showcase bulbs.

SEPARATE VISUALS



It features an easy access panel on either side for changing the transparencies. When a particular transparency is not lighted, the LT9 is designed to take on the appearance of smooth black glass.

TOUGH & HANDSOME

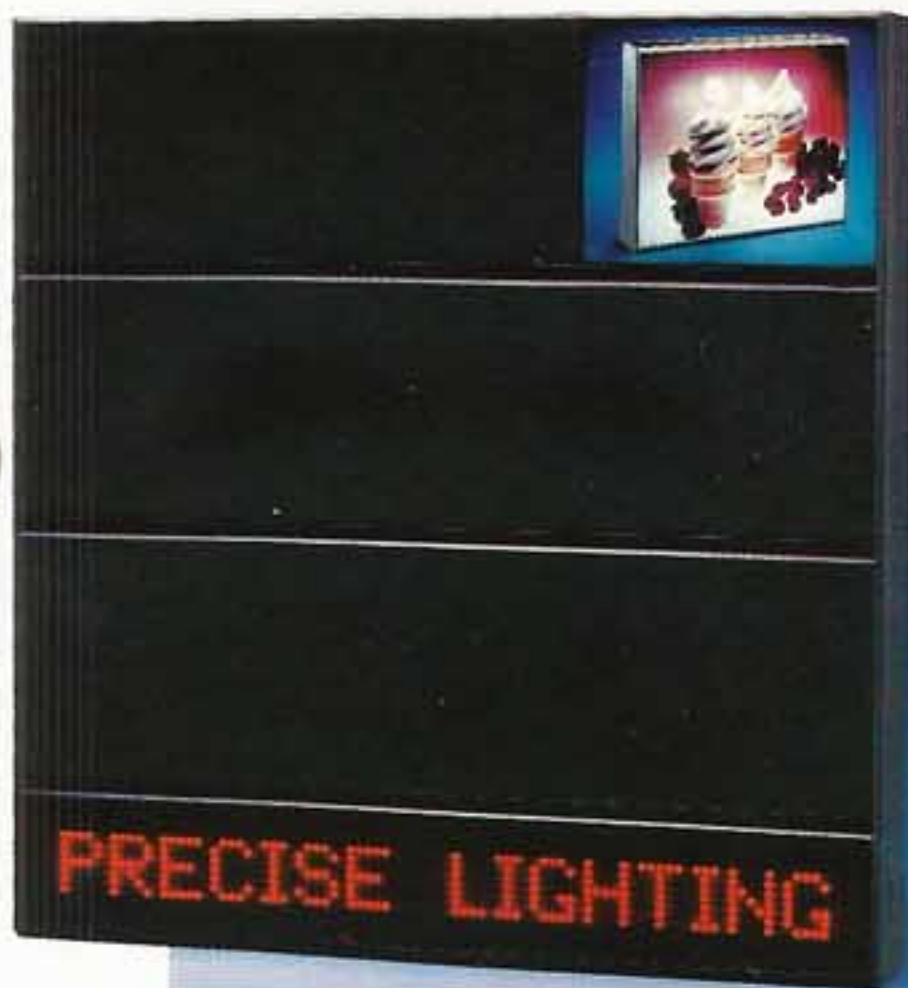

The lights can be programmed from the LED to go on and off at precise points within a message.

PRECISE LIGHTING



Up to four panels can be lighted at the same time.

FOUR AT ONE TIME



Program "rapid action" for extra attention grabbing excitement.

"RAPID ACTION"

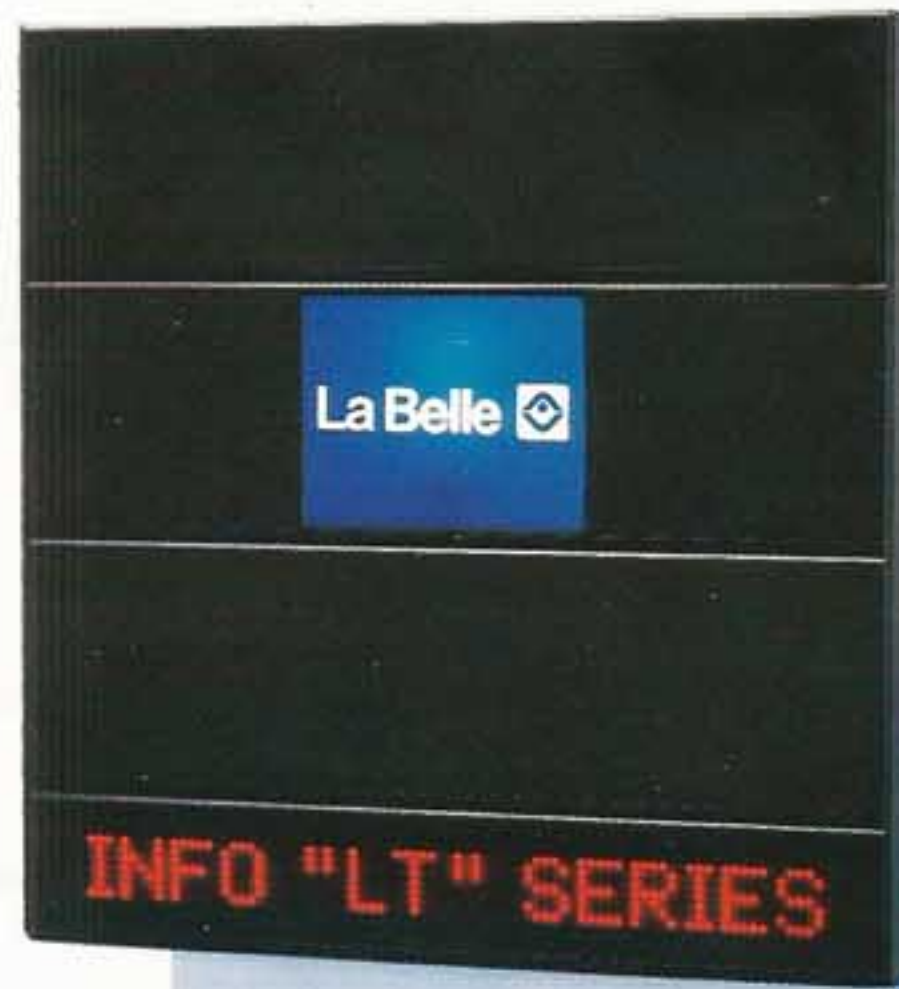

The Info LT Series — only from La Belle!

INFO "LT" SERIES

Info Display Modes & Functions

All INFO displays are simple to program and operate. Users will develop unique, effective messages in no time using the typewriter format programming keyboard. The keyboard also has 21 separate display options, ten (10) graphic characters, plus an editing mode to help you create dramatic eye-catching messages. Programmed messages can be recalled instantly with the touch of a key.

Individual light boxes are programmed by using ALT and SHIFT keys, simultaneously with numbered keys 1-0.

Built-in Graphics: (Are created with the ALT and desired graphic number key.)

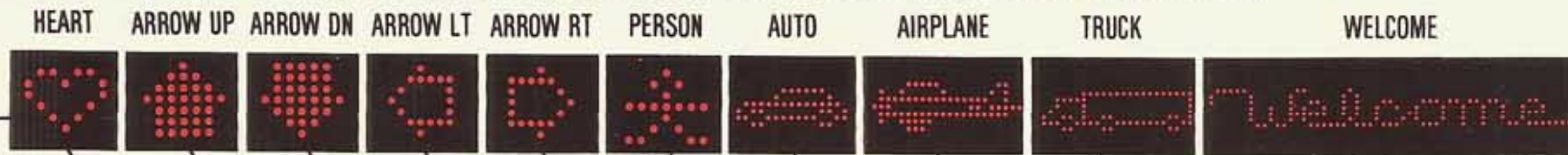

- ROT ←** Rotate Left. Message will rotate from right to left across screen.
- ROT** Rotate Right. Message will rotate from left to right across screen.
- KICK →** Kick Off. Message exits display to the right one character at a time.
- ← KICK** Kick On. Message enters display from the right one character at a time.
- WIPE** Wipe. Message covers preceding message left to right.
- OPEN** Open. Message expands to the left and right from the center of the display.
- CLOSE** Close. Message collapses from the left and right into the center of the display.
- DROP** Drop. Preceding message drops down to reveal new message.
- HOLD** Hold. Message is stationary for three seconds.
- HOLD ↑** Hold Up. Message is displayed for 1½ seconds, then moves up and off of the screen.
- HOLD ↓** Hold Down. Message is displayed for 1½ seconds, then moves down and off of the screen.

- SCRL ↑** Scroll Up. Message scrolls up from the bottom pushing the preceding message off screen.
- SCRL ↓** Scroll Down. Message scrolls down from the top pushing the preceding message off screen.
- BLINK** Blink. Message blinks on and off six times and then holds for one second.
- FLASH** Flash. Message flashes with a reversed background three times, then holds for one second.
- RANDOM** Random. Message randomly appears one dot at a time as the preceding message disappears.
- WIDE** Wide. Displays characters at twice their normal width.
- TIME** Time. Displays hours and minutes; also AM/PM.
- DAY** Day. Displays "Sunday" through "Saturday" alone, or within a given message.
- DATE** Date. Displays month and day.
- SPEED** Speed. Changes speed of other functions between normal and fast.

This LaBelle slide projector, built in 1955, came back for maintenance after 30 years and was promptly serviced and returned. Quality and service have been a LaBelle tradition for over 40 years and we back it with a full one-year parts and workmanship warranty on all INFO displays.



La Belle 

40 Years of Quality

ANALYSIS OF NEW ATTRACTION POTENTIAL

Light Parade

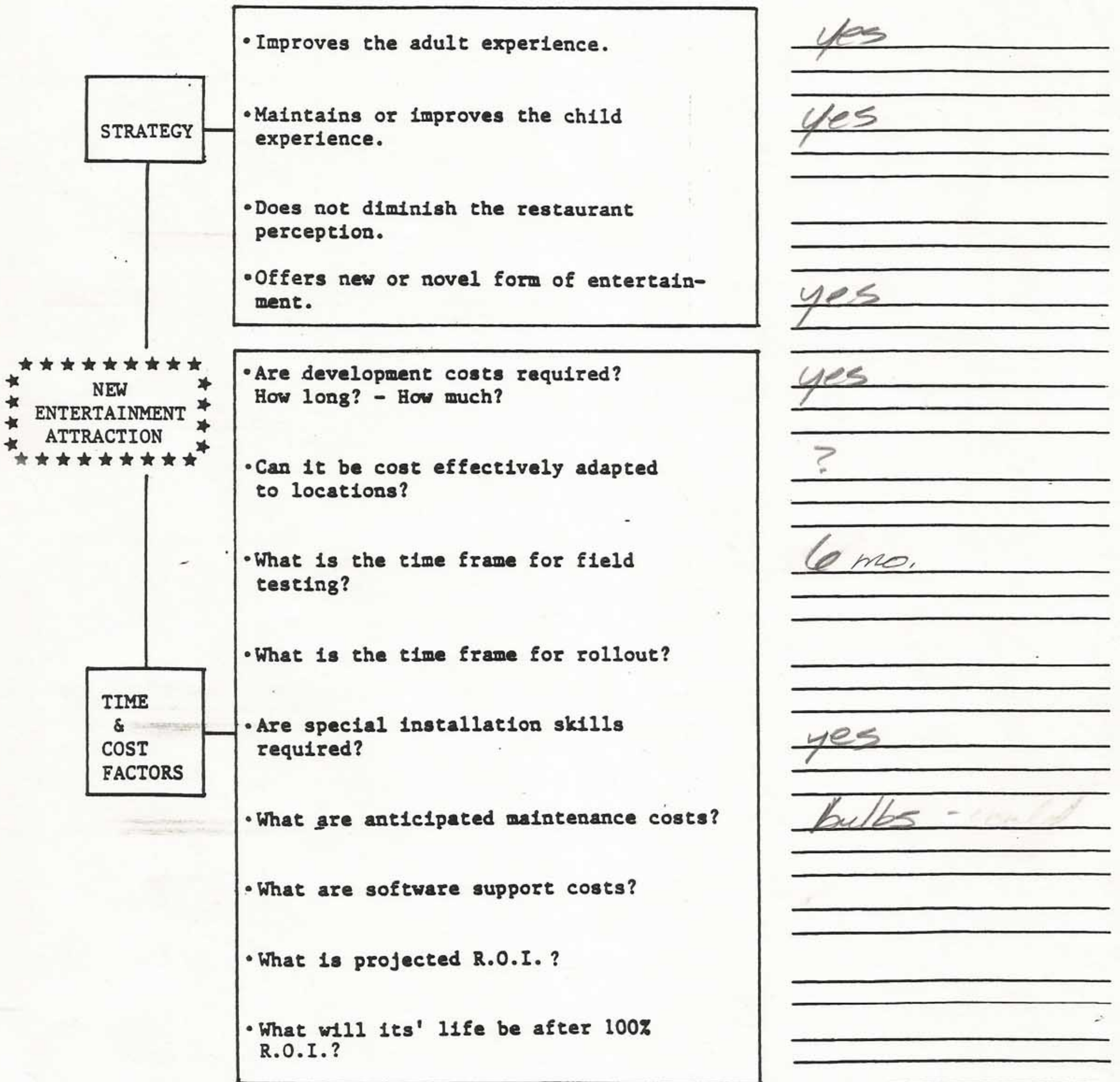



LASERMEDIA[®]
IMAGING THE FUTURE

ColorRAY System ©1986



RotorRay ©1986



FiberRay ©1986



Hand Held Beam ©1986

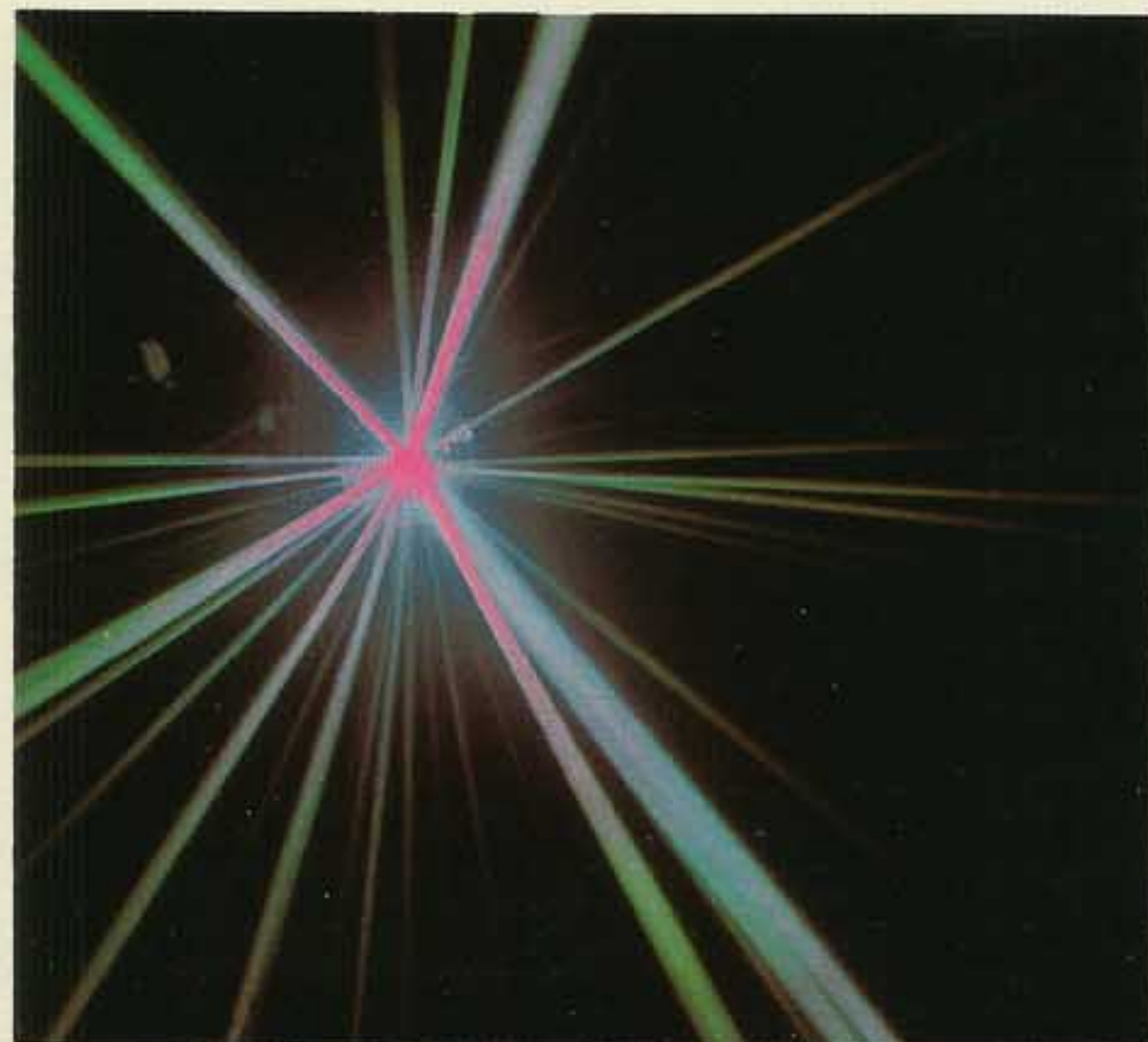

Mirror Ball ©1986



A TECHNOLOGICAL BREAKTHROUGH FULL COLOR SIMULATED LASER EFFECTS

- Low Cost
- Lightweight
- Compact and Powerful
- Low Maintenance
- Safe to Use
- No Government Regulations
- 110 Volt Household Current

Laser Media, Inc. introduces the most exciting and innovative special effects lighting system —the **ColorRay**. Creating simulated laser beams and effects, the **ColorRay** system will project multiple 3-Dimensional, color modulated effects consisting of digital tunnels, cones, fans, beams, 16-point prisms, hand-held beam pointers, and a variety of other effects.

The light source, mounted in a closed housing, will focus light into two 25 foot fiber optic cables and project the focused light into output accessories.

The uniquely-designed controller has an A and B side shutter with burst buttons, two motor controls, a keypad with 25 preprogrammed scanning effects, and a joy stick. Real time override controls access color, speed, and joy stick beam positioning. Multiple lamp houses and fiber outputs can be slaved from one controller.

BASIC **ColorRay SYSTEM**

- Controller
- Lamp House
- Two 25 Foot Fiber Optic Cables
- Two Collimators

OPTIONS

- RotorRay - (Rotary Prisms, Gratings, Beams)
- ScannerRay - (Fans, Tunnels, Cones, Beams)
- FiberRay - (Fans, Tunnels, Cones, Beams, Geometric Images)
- 3 Beam Box - (Static Colored Beams)

LASERMEDIA®

2046 Armacost Avenue
Los Angeles, California 90025
213-820-3750

Telex: 288898 LSMED UR
EMAIL: LASER-MEDIA-US

139 Spring Street
New York, New York 10012
212-431-8100

ANALYSIS OF NEW ATTRACTION POTENTIAL

Bubbles

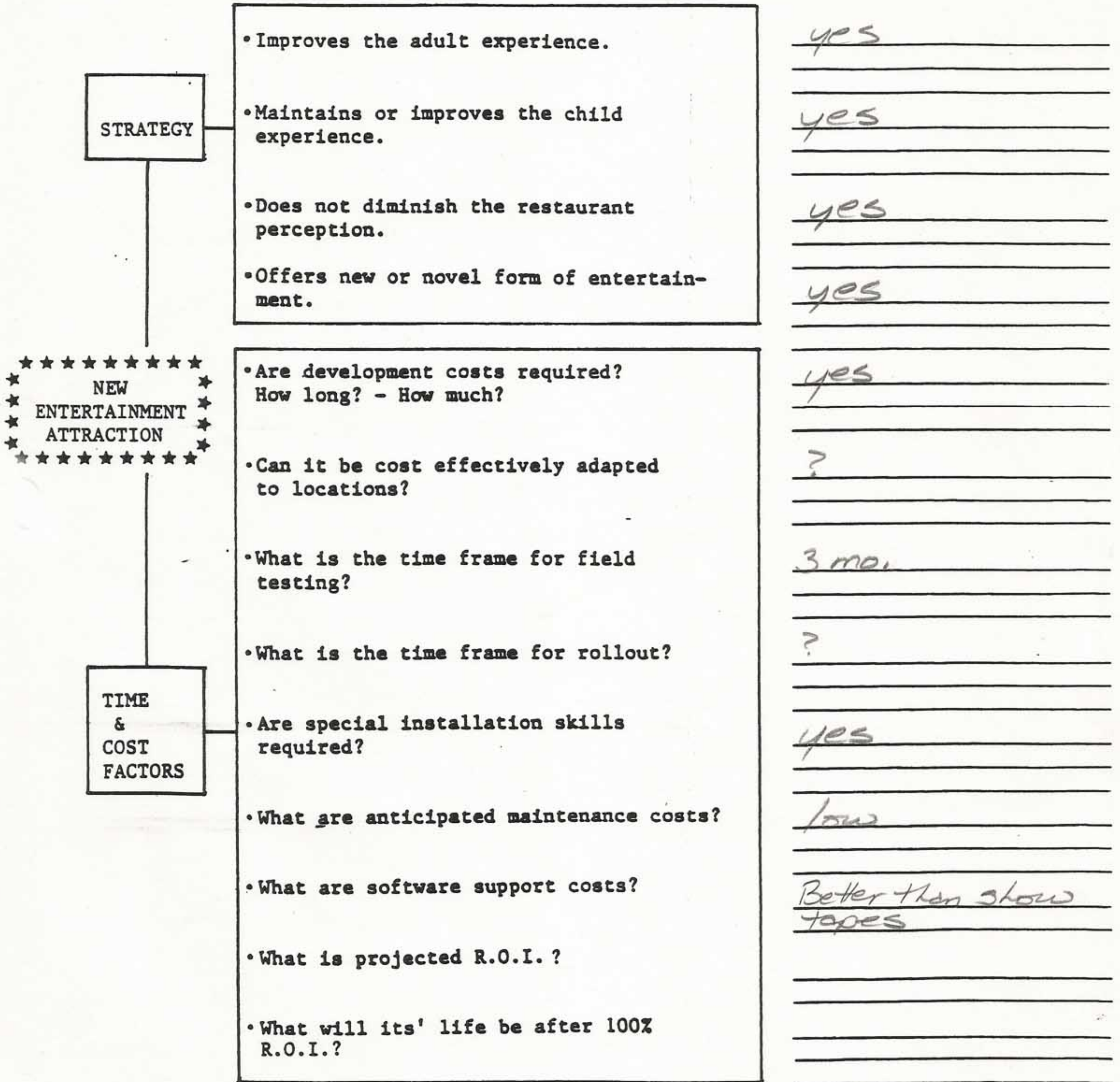

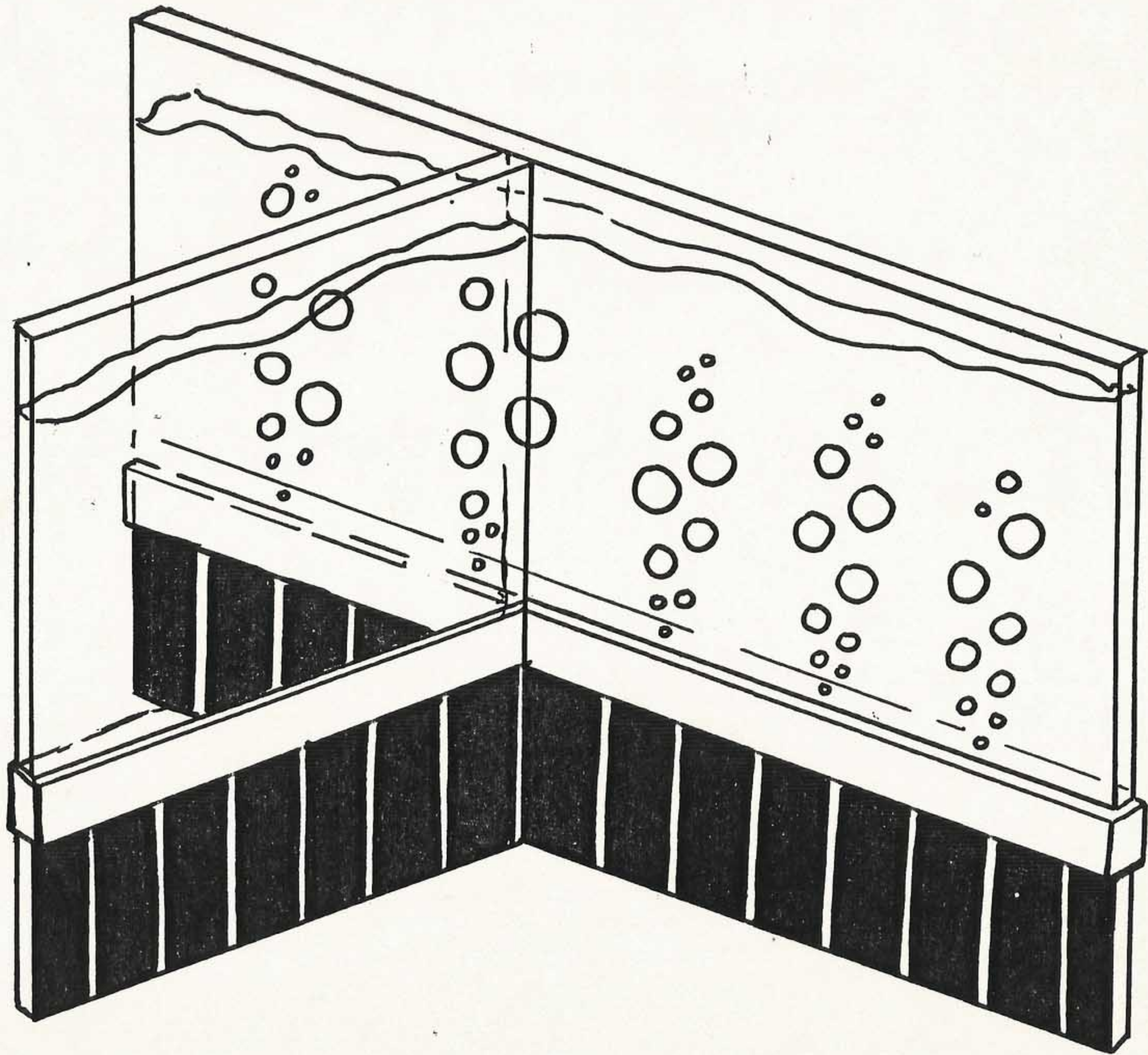

BRING IN THE CROWD!



an animated keyboard
that programs itself
from

THE ROBOT FACTORY

entertainment and promotional robots since 1966

NO PROGRAMING REQUIRED... THIS ANIMATION DOES IT ALL BY ITSELF!

In the past, animation systems were limited in the number of different shows they could perform because each movement of each show had to be separately programed by a human. And the humans couldn't meet the demand. But not any longer!

The Robot Factory's animated keyboard player currently has OVER 26 DIFFERENT SHOWS CONSISTING OF OVER 260 DIFFERENT MUSICAL NUMBERS available on computer disks. New disks are added daily and 10,000 musical numbers will soon be available.

HOW DOES IT WORK?

The music on the computer disk is what produces the character's movements. The computer in the keyboard "reads" the music and tells the character what movements to make. The character's hands move up and down the keyboard just as the notes do. His foot taps in time to the music. He sways and turns and his head bobs just like a human's. And he flashes smiles as he plays. In four short words - THE MUSIC MOVES HIM.

COMPUTER DISK BECAUSE...

Music on disk does not deteriorate over time as does music on tape.

Disks are easy to use, easy to store.

Music on disk faithfully reproduces the sound of the instrument.

MUSIC FOR EVERY TASTE,

from thigh-slapping player piano music sophisticated classics. And not just piano music. Push a button to switch among acoustic piano, electronic piano, harpsichord and clavichord. Each disk is themed - ragtime, Broadway shows, country, Gershwin, kids' favorites, Christmas and on and on.

PLUS A REGULAR KEYBOARD

Just move your furry friend over and you can play, too.

AND HE TALKS

by means of a cassette deck/microphone system. Use the cassette deck for pre-recorded (by you) comments and the microphone for live comments, conversation or even singing along.

TECHNICAL INFORMATION

The electronics are all solid-state. No air compressors are necessary.

The amplifier and speakers are built into the keyboard. Or you can plug into your own sound system for a bigger sound.

The system is self-contained with all components built into the keyboard and bench. (Exception is the cassette deck/microphone for talking which is used from a remote site.)

The character (body and head) lifts off the bench. One keyboard system can be used with interchangeable characters.

All music is on computer disks.

Music plays continuously and automatically.

MAINTENANCE

An owner's manual is provided. No additional training is required.

Insert your disk, plug the system in, set it for the desired keyboard instrument and adjust the volume.

Keep the keyboard and bench clean, brush the character's fur and protect the disks from damage. That's all there is to it.

DIMENSIONS (approximate)

Floor to top of head: 52 inches
Bench: 24 x 10 inches
Keyboard: 54 x 24 x 37 inches
Weight: 200 pounds

LIMITED WARRANTY

Covers parts and labor for 6 months from the date of the original purchase.

PRICING INFORMATION

Standard animated keyboard player \$12,900
(included at no charge is one demonstration disk)

Music disk, each \$ 40
(disks contain 10 musical numbers each and are available from Micro-W Distributing (Butler, NJ) - catalogs are available on request)

Additional standard characters . . . \$ 515
(custom characters available at additional cost)

(prices subject to change without notice)

TERMS OF PURCHASE: A 50% deposit at the time the sales agreement is signed is required, with the remaining 50% C.O.D., with the purchaser paying all shipping, insurance and C.O.D. charges.

THE ROBOT FACTORY

P.O. BOX 112
CASCADE, COLORADO 80809
(303) 687-6208 (303) 687-6244
TELEX 4725021



Micro-W Distributing Inc.

1342 ROUTE 23
BUTLER, N.J. 07405

(201) 838-9027

ShowBiz PizzaTime Inc.
4441 W. Airport Frwy.
Irving Texas 75062
Attn: Paul Linden

Thank you for taking time from your busy schedule to speak to me at the Amusement Show. I believe that our animated piano player would go a long way to enhance your entertainment.

The robot piano player system comes complete with a full size Technics PX-9 digital piano keyboard, keyboard stand, animated figure in your choice of over 10 decorator colors complete with bench, a Technics 3 1/2" disk drive, and 20 songs of your choosing from our library of over 10,000 selections. Also included, at no additional charge, is the talking robot option with mike or auto reverse tape recorder. Additional song disks are available for only \$39.95. A unique feature of the robot piano player system is the ability to add additional keyboards to increase the depth of the music. Keyboards manufactured by Korg, Roland, Yamaha, and Casio, will operate with this system.

Special characters can be constructed at additional costs although we find that character awareness can be achieved simply by dressing the unit in special clothes, adding hats, advertising buttons, or other items that coordinate the robot to your particular use. The robot is constructed from continuous duty motors and spring steel assuring total dependability in the field. It's covering is simply attached by velcro for easy removal. All solenoids are easily replaced and to date we have experienced complete customer satisfaction and exceptionally high reliability. For this reason, we warrant your robot for a period of 6 months for both parts and labor. A complete kit of motors and solenoids that can replace all moving parts is only \$375.00. I can also assure you that a quantity purchase will warrant a special discount schedule. For additional information, please don't hesitate to call us at (201) 838-9027 Monday through Friday from 10AM to 6PM EST. In addition to the robot piano player, we also sell the QRS electronic player pianos that play the paper roll music recordings that are still available today. The price of these units are \$3495 and all QRS player pianos are shipped FOB Buffalo, New York. Please allow at least 8 weeks for delivery and all orders require a \$750 deposit.

Micro-W Distributing Inc.

1342 ROUTE 23
BUTLER, N.J. 07405

(201) 838-9027

If you have a use for the music of the old player pianos but enjoy the availability, extended play, and ease of use of computer disks; we offer an electronic keyboard and computer music systems that start as low as \$995. Based on either the Commodore or Apple compatible systems, these hi-tech player synthesizers offer much more than just piano type sounds. If you are interested you may request our demo tape of selected music played by one of these systems. These systems can easily be programmed to sound like and replace a standard instrument or be integrated into an animation.

We thank you very much for taking an interest in our unique entertainment devices. We are sure that you will be amazed by the excitement that is generated by our robot piano player should you choose to place them in your establishments. Robot systems are shipped FOB from either Colorado Springs, Colorado or Butler, New Jersey depending on your location.

Respectfully



Lou Ploch President
Micro-W Distributing Inc.

PS - We have studio musicians, jingle writers, composers, computer software and hardware design engineers, artists, entertainers, and other assorted personnel to cater to your needs. If you have any special requests, please let us know so that we may be of any assistance. We will be happy to quote prices for items that we can supply or direct you to someone that will be able to help you with your special needs.

OUR MUSIC BRINGS IN THE CROWD

The best way to attract people is with entertainment. Restaurants, lounges, amusement parks, trade show exhibitors, and grand openings have all been enhanced with live entertainment. The trick is to keep the cost down so that your profits are increased. Our music entertainment systems combine the excitement of live music with a library of thousands of songs at a surprisingly low price.

Now you can have music every day and night with our animated robot piano player. We've got thousands of songs to choose from to cover every musical taste, played on a professional quality instrument, by a fun furry robot. He can even talk to the crowds, sing, and tell jokes. And you can even move the robot aside so that a pianist can use the instrument.

The robot is made by an established leader in the design and manufacture of entertainment robots since 1966. The keyboard is manufactured by the Technics division of Panasonic and it faithfully reproduces the sound of a concert grand piano. Additional

keyboard synthesizers from Yamaha, Casio, Korg, and Roland can be added. The song library ranges from thigh-slapping player piano music licensed from the QRS player piano roll library, to sophisticated dinner music and classics.

The entire system takes up less space than a standard upright piano and bench. It can plug into your own sound system or you can use it with a stand alone amplifier. Complete ready to play robot systems start at only \$12,900. We can also supply the new electronic, paper roll playing, player pianos from QRS and we can provide computer systems (from \$599) to play any existing MIDI keyboard that your establishment may own.

BRING IN THE CROWD WITH
AFFORDABLE MUSIC SYSTEMS FROM:

Micro-W.
DISTRIBUTING, INC.

1342 B Route 23
Butler, N.J. 07405

201-838-9027





Micro-W.
DISTRIBUTING, INC

1342 B Route 23
Butler, N.J. 07405
201-838-9027

Technics

SX-PX9



PCM
DIGITAL PIANO

Rich sound and refined styling for a wealth of creative possibilities.

MIDI Functions

FD Recorder Terminal

PCM Digital Sound

Pulse Code Modulation, or PCM, is a method of digitally recording the sounds of live instruments and storing them in computer memory chips. The SX-PX9 contains the sounds of five authentic instruments: piano, electric piano I & II, harpsichord and clavi. As a result, this single keyboard offers a multitude of musical expressions: the rich, robust sound of a concert grand, the mellow or metallic tones of electric piano I & II, or the light and lively rhythms of harpsichord and clavi.

The SX-PX9. Accept its invitation to perform.

Touch Response

Just like the keys of an acoustic piano, the keys of the SX-PX9 respond to the slightest change in touch with a corresponding increase or decrease in volume as well as a natural change in harmonics. Unlike its acoustic counterpart, however, the SX-PX9 relies on an enormous storage of sound sampling data linked to the forces of finger pressure and key movement. The result is a remarkably sensitive keyboard that responds to your touch with all the expressive depth and subtlety of the acoustic piano.

2-Channel Play Sequencer and Floppy Disk I/O Terminal

The SX-PX9 can remember your every note. In fact, it can store and play back, upon request, all of your performance data, foot pedal data, effects and changes in timbre. The SX-PX9 enables storage of one complete tune of 2,700 notes or two short tunes of up to 1,350 notes each. Or store two parts of the same tune, each part up to 1,350 notes long, then play them back simultaneously. By connecting a Technics Digital Disk Recorder to the I/O terminal of the SX-PX9, you can expand the storage capacity up to ten times for each floppy disk, thereby enabling a vast library of your performances. Just think of the possibilities: storing one part of a duet, then accompanying yourself with the other. Or providing the stage musician with an automatic repertoire.

MIDI Controls

With the MIDI terminals, you have synchronized multi-control of any MIDI-compatible instrument, even a compatible personal computer. Since MIDI is a world standardized musical interface, the problem of cross-brand

interference is eliminated.

The "MIDI Conductor" split keyboard puts you in command of up to two external instruments, and even allows you to mix the sounds of these external instruments with the master sound of the SX-PX9. The programmable "MIDI Full Set" function also transfers control of the "MIDI Conductor" and program changes, including several effects, in external instruments to the SX-PX9 keyboard.

Chorus/Tremolo

Surround your performance with the rich sound of the chorus and/or tremolo effect. You can also control tremolo speed.

Key Transpose and Tuning Control

Changing keys couldn't be easier, and tuning with other instruments takes seconds.



The backside view of the SX-PX9.



Rear Terminals

Optional Accessories

SY-T80
Tone Cabinet



SY-FD5 Digital Disk Recorder



Specifications SX-PX9 (Tentative)

• **Keyboard:** 88 keys (Plastic) • **Tone Selector:** piano, electric piano I, II, harpsichord, clavi
• **Effects:** brilliance (mellow, bright, normal), tremolo/speed, chorus, sustain pedal, soft pedal
• **Play Sequencer:** start/stop, tempo, metronome, record, song I, II, (or long play) • **MIDI:** conductor (R — master, ext. A/B, octave down 1-3), (L —

master, ext. A/B, octave up 1-3), program change A, B, MIDI full set, terminals (in, out, thru)
• **Others:** main volume, transpose, power switch, tune, pedal in terminals (sustain, soft), aux in terminals (R/R+L, L), line out terminals (R/R+L, L), line out level (high/low), ext. I/O (Floppy Disk) terminal, headphone jack • **Output:** 13W x 2

• **Speakers:** 20cm (7 7/8"), 8cm (3 1/2") • **Power Requirement:** AC 120V, 60Hz, 68W
• **Dimensions (W x H x D):** 1378 x 856 x 51.4cm (54 1/4" x 33 1/16" x 20 1/4") (with stand) • **Net Weight:** 60kg (132.3 lbs.) (with stand)
• **Accessories:** cloth cover, wood stand, sustain pedal, soft pedal, music rack, AC cord

Technics

Panasonic Company
Division of Matsushita Electric Corporation of America
WESTERN GROUP: PANASONIC LOS ANGELES 6550
Katella Avenue, Cypress, CA 90630 (714) 895-7200

PLAYER PIANO OWNER'S GUIDE

featuring our complete

QRS PIANO ROLL CATALOG

1986-87 Edition

Enjoy These Sparkling New Rolls For ALL Player Pianos ...

LONG PLAYING JUST RELEASED!

- | | | |
|---|---|---|
| ★ '54-'55 Rock 'n' Roll
(XP-254-B)
The Great Pretender; Sincerely | ★ '54-'61 Elvis Presley
Rock 'n' Roll (XP-256-B)
Jailhouse Rock; Don't Be Cruel | ★ 1962 Rock 'n' Roll
(XP-258-B)
Palisades Park; Twist and Shout |
| ★ '57 Rock 'n' Roll
(XP-255-B)
At The Hop; Come Go With Me | ★ '62-'67 Beach Boys
Rock 'n' Roll (XP-257-B)
Fun, Fun, Fun; Surfer Girl | ★ Everly Brothers
Rock 'n' Roll (XP-259-B)
Bye, Bye Love, All I Have To Do Is Dream |

Throw away your pumping shoes, these rolls play for up to 20 minutes!

RECENT LONG PLAYING RELEASES

THE MUPPET MEDLEY (XP-244-B) Muppet Show Theme; The Rainbow Connection. **COLE PORTER CLASSICS (XP-245-C)** Wunderbar; C'est Magnifique; It's D'Lovely; I Love Paris. **DIXIELAND CLASSICS (XP-246-C)** Copenhagen; Midnight In Moscow; That's A-Plenty. **JUDY GARLAND MEDLEY (XP-248-C)** Zing! Went The Strings Of My Heart; You Made Me Love You; Over The Rainbow; Trolley Song. **THE BIG CHILL MEDLEY (XP-249-C)** The Tracks Of My Tears; It's The Same Old Song; Dancing In The Streets; My Girl; (You Make Me Feel Like) A Natural Woman; When A Man Loves A Woman. **GEMS FROM GIGI (XP-250-C)** Gigi; The Night They Invented Champagne; I Remember It Well; Thank Heaven For Little Girls. **KATE SMITH REMEMBERED (XP-251-C)** When The Moon Comes Over The Mountain; God Bless America; Marching Along Together; Goodnight Sweetheart. **BENNY GOODMAN — KING OF SWING (XP-252-C)** Let's Dance; I Got It Bad And That Ain't Good; Sing, Sing, Sing; And The Angels Sing. **RUDY VALLEE TIME (XP-253-C)** My Time Is Your Time; Something To Remember You By; U. Of Maine Stein Song; (Yale) Whiffenpoof Song. **DISNEY CLASSICS (XP-235-B)** When You Wish Upon A Star; Mickey Mouse Club March; It's A Small World. **ANNE MURRAY HITS (XP-236-C)** Another Sleepless Night; Snowbird; You Needed Me. **BILLY JOEL HITS (XP-237-C)** My Life; Just The Way You Are; Uptown Girl; The Longest Time. **SACRED FAVORITES (XP-238-B)** Will The Circle Be Unbroken; The Old Rugged Cross; Rock Of Ages. **NEIL DIAMOND HITS (XP-239-C)** Sweet Caroline; Song Sung Blue; Love On The Rocks; Cracklin' Rosie. **JAMES BOND THEMES (XP-240-C)** Nobody Does It Better; Live And Let Die; You Only Live Twice; Casino Royale. **GLENN MILLER HITS Vol. III (XP-241-B)** Juke Box Saturday Night; Sunrise Serenade; In The Mood. **THE BEST OF BRUCE SPRINGSTEEN (XP-242-A)** Dancing In The Dark; Born In The USA. **PATSY CLINE HITS (XP-243-B)** Walkin' After Midnight; Sweet Dreams; I Fall To Pieces; Crazy. **STATUE OF LIBERTY (XP-247-C)** (Profusely illustrated collector's commemorative roll.) America The Beautiful; This Land Is Your Land; God Bless America; Columbia, Gem Of The Ocean; Stars And Stripes Forever.

NEW SING-ALONG SINGLES

- | | |
|---|--|
| LINUS AND LUCY (from Peanuts) (10-842) | GLORY OF LOVE (Theme from Karate Kid II) (10-852) |
| GRANDMA GOT RUN OVER BY A REINDEER (10-843) | THAT WAS THEN, THIS IS NOW (Monkees) (10-853; Oct. 15) |
| PART TIME LOVER (10-844) | FRIENDS AND LOVERS (Gloria Loring & Carl Anderson)
(10-854; Nov. 7) |
| ST. ELMO'S FIRE (Instrumental) (10-845) | TAKE THIS JOB AND SHOVE IT (Johnny Paycheck) (10-855;
Nov. 7) |
| SAY YOU, SAY ME (10-846) | VENUS (Bananarama) (10-856; Nov. 14) |
| THAT'S WHAT FRIENDS ARE FOR (10-847) | TAKE MY BREATH AWAY - Theme from TOP GUN (Berlin)
(10-857; Nov. 21) |
| ST. ELSEWHERE (Theme From) (10-848) | |
| MANIC MONDAY (10-849) | |
| THE GREATEST LOVE OF ALL (10-850) | |
| BORN IN THE USA (10-851) | |



QRS MUSIC ROLLS • 1026 NIAGARA ST. • BUFFALO, N.Y. 14213

HOW TO ORDER

Q-R-S is primarily a manufacturer — not a mail order house. We encourage you to order any item in our catalog through your local Q-R-S dealer.

If your dealer cannot fill your order from stock, have him pick up the phone and call us immediately. There's no need to wait for the Q-R-S rolls you want! We can even ship the rolls to your home — just tell your dealer you want your rolls "drop-shipped".

PROBLEMS? We solve 'em. If you have no Q-R-S dealer, or have any difficulty obtaining any item in our catalog, call us on the ...

Q-R-S HOTLINE DIAL (716) 88-N-O-T-E-S (886-6837)

**Weekdays — 9 a.m. to 5 p.m.
Eastern Time**

We will ship immediately any and all rolls currently in production. You may charge them to your Mastercard or Visa, or we can send them COD. When calling, be prepared to give us the name and address of your Q-R-S Dealer so we can credit him with the sale.

Remember, seeing your local Q-R-S Dealer is the best way to purchase rolls — but we're here to make sure you can always get rolls you want.

THE VESTAL PRESS

is your headquarters
for books on

- **PLAYER PIANOS**
- **MUSIC BOXES**
- **CAROUSELS**
- **ANTIQUÉ RADIOS**
- **ANTIQUÉ
PHONOGRAPHS**
- **REED ORGANS**
- **RECORDS AND
TAPES**

If nostalgia, collecting
or just good reading and
listening turn you on . . .
send \$2.00 (refundable) for **BIG**
56 page catalog.

THE VESTAL PRESS
(Dept. Q)
P.O. Box 97 • Vestal, N.Y. 13850

A Message From Q-R-S

Every business day since the turn of the century, Q-R-S Player Rolls have been made, sold, and enjoyed. Not many products can make that claim!

We proudly continue to bring you the world's favorite piano rolls — unchallenged for their terrific variety, musical superiority, consistent high quality and proven durability. We are your source for the newest, the oldest, and the longest rolls by the greatest pianists, past and present.

Everything you need for the maximum enjoyment of your player piano is contained in these pages. In addition to rolls you'll find specially selected accessories, books, records and tapes; our very first video; and lots of helpful information we've gathered during 85 years as the world's leading roll maker.

Browse through our pages. You'll find much to entice you. Then see your dealer — and accept our thanks for your order!

Remember: Q-R-S Player Rolls are Better!

VISITORS



FREE Q-R-S FACTORY TOURS

Monday through Friday at 10 a.m. and 2 p.m. only! Year 'round except the last week of July and the first week of August. See Q-R-S rolls and pianos made!

We are closed weekends and the days surrounding major holidays. Any doubts as to 'open' dates can be resolved by phone (716) 885-4000 or letter.

For safety reasons, we discourage tours for children under age seven. Sorry, we have no facilities for the handicapped.

Buy A Brand New Player Piano

- **MANUFACTURERS LIST** •
**Q-R-S PLAYER PIANO
CORPORATION**

1026 Niagara Street, Buffalo, NY 14213

CLASSIC (Universal) PLAYER PIANO

RD#2 Box 138C, Seneca, PA 16346

THE WURLITZER COMPANY

403 E. Gurler St., DeKalb, IL 60117

McDERMED-ROUSE P.O. Box 24, Fishers, IN 46038

PLAYER PIANO CENTER
2319 Metairie Rd., Metairie, LA 70001

REPAIR PARTS FOR ALL PLAYER AND REPRODUCING PIANOS

Send \$3.50
For Complete Catalog
Player Piano Co.

704 E. Douglas
Wichita, Kansas 67202
(316) 263-3241

CUSTOM ROLLS

We can copy your old rolls or make your special favorite from sheet music. For **CUSTOM ROLL ORDER FORM**, send a self-addressed, stamped envelope to Q-R-S Music Rolls, Inc., 1026 Niagara St., Buffalo, N.Y. 14213.

COMING SOON!

The world's largest selection of Ampico and Duo-Art Rolls as well as rolls for Band Organs, Orchestrions and Coin-Operated Pianos. See "Ballot Box" on inside back cover.

FREE INFO

Send self-addressed, stamped envelope for the answers to questions about player pianos and rolls. This valuable information helps you maximize enjoyment of your player piano.

JOIN THE CLUBS

AMICA

Automatic Musical Instrument Collectors' Association (paper roll playing instruments). Write to AMICA, P.O. Box 172, Columbia South Carolina 29202.

— OR —

MBS

Musical Box Society. Write to Warren Wolf, 940 S. Stone LaGrange, Illinois 60525.

ALPHABETICAL LISTING

CONTENTS

Academy Award Winners	18
Accessories	20, 21, 23
Alphabetical Listing	3-10
Ampico Rolls	11
Ballot Box	23
Best of the 20's	17
Best of the 30's	17
Best of the 40's	18
Big Bands	18
Books	20
Broadway Medleys	14
Celebrity Series	13
Children's Music	19
Christmas Music	Back Cover
Classical Music	19
Country & Western Music	12
Dance Music	18
Deluxe Custom Roll Service	21
Duo-Art Rolls	11
Educator Set	23
Electric Conversion Kit	21
Grammy Award Winners	19
Home Minstrel Series	17
HOW TO BUY	2
International Music	18
Jazz Personality Series	16
Long-Playing Rolls	14-15
Marches & Patriotic Music	16
Music Disks (Computer)	23
New Player Pianos	2
New Releases	Cover
Play-Along Rolls	18
Polkas	18
Posters	23
Ragtime & Blues	16
Recordo Rolls	11
Records & Tapes	21
Roll Racks & Cabinets	23
Roll Repair Parts	2
Sacred Music	12
St. Patrick's Day Music	18
Silent Movie Music	17
Top 100	16
T-Shirts	21
TV Trivia Set	23
Video Cassette	21
Werte Test Roll	20

PRICE CODES AND OTHER SYMBOLS

There are four price categories. See your dealer for current roll prices.

1. Regular rolls bear no price code.
2. Code A rolls (formerly (* and †))
3. Code B rolls (formerly ††)
4. Code C rolls (formerly †††)

OTHER SYMBOLS:

- C - before a number indicates a classical selection
- CEL - indicates a live-played Celebrity Series Roll
- Q - indicates a reissued roll
- WF - indicates foreign lyrics
- XP - indicates a long-playing roll
- (m) - after a title indicates a marimba or tremolo arrangement
- (R and D have no meaning)

READY SOON!

(Note Release Dates)

- **THAT WAS THEN, THIS IS NOW (Monkees) (10-853; Oct. 15)**
- **FRIENDS AND LOVERS (Gloria Loring & Carl Anderson) (10-854; Nov. 1)**
- **TAKE THIS JOB AND SHOVE IT (Johnny Paycheck) (10-855; Nov. 7)**
- **VENUS (Bananarama) (10-856; Nov. 14)**
- **TAKE MY BREATH AWAY — Theme from TOP GUN (Berlin) (10-857; Nov. 21)**

—A—

- | | |
|-----------|---|
| Q-261 | "A" YOU'RE ADORABLE |
| 8705 | THE ABA DABA HONEYMOON |
| 121 | ABIDE WITH ME |
| | ABOUT A QUARTER TO NINE (See Forty-Second Street) |
| | ABSENCE MAKES THE HEART GROW FONDER (See Favorite Old-Time Waltzes) |
| 9239 | ACE IN THE HOLE |
| | THE ADDAMS FAMILY (Theme) (See TV Trivia Set) |
| 1948 | AFTER THE BALL (see also Old Fashioned Waltzes) |
| 10-580 | AFTER THE LOVIN' |
| 561 | AFTER YOU'VE GONE (fox trot) |
| 10-567 | AFTERNOON DELIGHT |
| 10-810 | AGAINST ALL ODDS (Take A Look At Me Now) |
| | THE AGGIE SONG (see Best Little Whorehouse) |
| | AIDA (see Echoes From The Metropolitan Opera House) |
| | AINT DAT A SHAME (see Popular Songs Of Other Days) |
| 7883 | AINT MISBEHAVIN' |
| XP-183-B | AINT MISBEHAVIN' |
| | 1. Ain't Misbehavin'; 2. I Can't Give You Anything But Love; 3. 'Tain't Nobody's Bizness If I Do; 4. Squeeze Me; 5. Honeysuckle Rose |
| Q-111 | AINT SHE SWEET? |
| Q-268 | AINT WE GOT FUN |
| 9877 | AL-DI-LA ('Rome Adventure') |
| 9180 | ALDONZA (See Man of LaMancha) |
| Q-269 | ALABAMA JUBILEE |
| 3070 | ALABAMA BOUND |
| | ALEXANDER'S RAGTIME BAND (see also Irving Berlin) |
| 1220 | ALFIE (see Burt Bacharach Medley) |
| | ALICE BLUE GOWN (waltz) |
| | ALL I CARE ABOUT IS LOVE (see Chicago Medley) |
| Q-232 | ALL I DO IS DREAM OF YOU |
| | ALL I HAVE TO DO IS DREAM (see '57-'62 The Everly Bros. Rock 'n' Roll) |
| 8455 | ALL I WANT FOR CHRISTMAS IS MY TWO FRONT TEETH |
| | ALL IN THE FAMILY |
| 10-467 | THOSE WERE THE DAYS (opening theme) |
| CEL-176-A | THOSE WERE THE DAYS (played by comp. C. Strouse) |
| 10-476 | REMEMBERING YOU (closing theme) |
| 10-801 | ALL NIGHT LONG (ALL NIGHT) |
| 8300 | ALL OF ME (fox trot) |
| CEL-160-A | ALL THE THINGS YOU ARE (played by Peter Duchin) |
| 9517 | ALL THE WAY (from the "The Joker Is Wild") |
| 10-796 | ALL TIME HIGH (from "Octopussy") |
| 9319 | ALLEGHENY MOON (waltz) |
| 9879 | ALLEY CAT (Omkring Et Flygel) |
| CEL-116-A | ALLEY CAT (played by Liberace) |
| | ALMOST LIKE BEING IN LOVE (see Brigadoon) |
| 171 | ALOHA OE (Farewell to Thee) |
| 3413 | ALWAYS (see also Irving Berlin Medley) |
| 10-763 | ALWAYS ON MY MIND |
| 4720 | AM I BLUE? (m) |
| XP-232-B | AMADEUS |
| | 1. Piano Concerto in D minor, K. 466; 2nd movement; 2. Concerto for Two Pianos, K. 365; 3rd movement; 3. Piano Concerto in E flat, K. 482; 3rd movement |
| 7384 | AMAPOLA — PRETTY LITTLE POPPY (fox trot) |
| 10-481 | AMAZING GRACE (Hymn) |
| 183 | AMERICA (MY COUNTRY 'TIS OF THEE) |
| 7813 | AMERICA THE BEAUTIFUL (patriotic song) (see also Statue of Liberty) |
| C-137-A | AN AMERICAN IN PARIS (Pt. 1) (Gershwin) |
| C-138-A | AN AMERICAN IN PARIS (Pt. 2) |
| 10-468-A | AMERICAN PIE |
| 4155 | AMONG MY SOUVENIRS |
| CEL-190-A | AMTRAK BOOGIE WOOGIE (played by Ferrante & Teicher) |

- | | |
|-----------|---|
| 4961 | ANCHORED (see Sea Songs) |
| 10-582 | ANCHORS AWEIGH |
| | AND ALL THAT JAZZ (see also Chicago) |
| 10-691 | AND I LOVE YOU SO |
| | AND THE ANGELS SING (see Benny Goodman — King of Swing) |
| XP-219 | ANDREWS SISTERS MEDLEY |
| | 1. Don't Sit Under The Apple Tree; 2. Apple Blossom Time; 3. Bei Mir Bistu Schoen |
| 10-720 | ANGEL OF THE MORNING |
| | ANGELS WE HAVE HEARD ON HIGH (see Christmas Greetings) |
| Q-207 | ANIMAL CRACKERS IN MY SOUP |
| XP-180-B | ANNIE (pt. 1) exclusive live performance by the show's composer, Charles Strouse |
| | 1. Maybe; 2. It's The Hard Knock Life; 3. Tomorrow; 4. We'd Like To Thank You; 5. Little Girls; 6. I Think I'm Gonna Like It Here |
| XP-181-B | ANNIE (pt. 2) |
| | 1. NYC; 2. Easy Street; 3. You Won't Be An Orphan For Long; 4. You're Never Really Dressed Without A Smile; 5. Something Was Missing; 6. I Don't Need Anything But You; 7. Annie |
| XP-142-B | ANNIE GET YOUR GUN (pt. 1) |
| | 1. There's No Business Like Show Business; 2. My Defenses Are Down; 3. Anything You Can Do; 4. Girl That I Marry; 5. You Can't Get A Man With A Gun |
| XP-143-B | ANNIE GET YOUR GUN (pt. 2) |
| | 1. I Got The Sun In The Morning; 2. Moonshine Lullaby; 3. Who Do You Love I Hope; 4. I Got Lost In His Arms; 5. Doin' What Comes Nat'rally; 6. They Say It's Wonderful |
| | ANNIE ROONEY (see Old Fashioned Waltzes and Popular Songs of Other Days) |
| 10-523 | ANNIE'S SONG |
| CEL-189-A | ANNIE'S SONG (played by Ferrante & Teicher) |
| 8193 | ANNIVERSARY SONG (Oh, How We Danced) |
| 7546 | THE ANNIVERSARY WALTZ |
| | ANOTHER AUTUMN (see Paint Your Wagon) |
| | ANOTHER SLEEPLESS NIGHT (see Anne Murray Hits) |
| 10-538 | (HEY, WON'T YOU PLAY) ANOTHER SOMEBODY DONE SOMEBODY WRONG SONG |
| XP-234-A | ANTIQUA AUTOMOBILE SONGS |
| | 1. See The U.S.A. In Your Chevrolet; 2. My Buick, My Love, And I; 3. The Little Ford Rambled Right Along; 4. Ray And His Little Chevrolet; 5. Rolls Royce Papa, Your Tin Lizzie Mama Is Gonna Tow You In; 6. He'd Have To Get Under (Get Out and Get Under) |
| 64-530-A | ANVIL CHORUS (Verdi) |
| 10-774 | ANY DAY NOW |
| | ANY ICE TODAY, LADY (see Roaring 20's Party Roll) |
| 8803 | ANY TIME (fox trot) |
| 9228 | ANYTHING GOES (from "Night and Day") |
| | ANYTHING YOU CAN DO (see Annie Get Your Gun) |
| CEL-188-A | THE APARTMENT (Theme From) (played by Ferrante & Teicher) |
| CEL-175-A | APPLAUSE (from "Applause") |
| 7413 | (IN) APPLE BLOSSOM TIME (see also Andrews Sisters) |
| Q-157 | APRIL SHOWERS (see also Al Jolson Hits) |
| 10-317 | AQUARIUS |
| 3985 | ARE YOU LONESOME TONIGHT? (see also Elvis Presley, Vol. 3) |
| 3807 | THE ARKANSAS TRAVELER (barn dance) |
| 7656 | ARMY AIR CORPS |
| 9522-A | AROUND THE CHRISTMAS TREE |
| | 1. From Heaven I Was Sent To Earth; 2. Oh Come Little Children; 3. Oh Faithful Pine; 4. Holy Night; 5. Come Hither Ye Faithful; 6. Tomorrow Will Be Christmas Day; 7. O Sanctissimo; 8. The Sleighride |
| | AROUND THE WORLD (waltz) |
| 9455 | ARRIVEDERCI, ROMA (Good-Bye To Rome) |
| 9245 | ARTHUR'S THEME (BEST THAT YOU CAN DO) |
| 10-736 | ARTIST'S LIFE (KUNSTLERLEBEN) |
| 7027 | AS LONG AS HE NEEDS ME (see also Oliver!) |
| 9897 | AS TIME GOES BY |
| 8861 | ASLEEP IN THE DEEP (see Sea Songs) |
| | AT LAST (see Glenn Miller Hits Vol. 2) |
| | AT THE BALLET (see A Chorus Line) |
| | AT THE HOP (see '57 Rock 'n' Roll) |
| Q-247 | A-TASKET, A-TASKET (played by 'Fats' Waller) |
| 1249 | AULD LANG SYNE (see also Happy Birthday, Santa Claus Time, and Yuletide Song Medley) |
| 9518 | AUTUMN IN NEW YORK |
| 9525 | AUTUMN LEAVES |
| CEL-130-A | AUTUMN LEAVES (played by Roger Williams) |
| 69-690 | AVE MARIA (Schubert) |

- | | |
|--------|---------------------------------|
| 1391 | AVE MARIA (Bach-Gounod) |
| 3316 | AWAY IN A MANGER |
| 10-839 | AXEL F (from Beverly Hills Cop) |

—B—

- | | |
|-----------|---|
| | BABY DON'T GET HOOKED ON ME (see Mac Davis) |
| | BABY FACE |
| Q-180 | BABY, IT'S COLD OUTSIDE |
| 8519 | BABY JUNE AND HER NEWSBOYS (see Gypsy Med. pt. 1) |
| CEL-141-B | BURT BACHARACH MEDLEY (played by Liberace) 1. Close To You; 2. Alfie; 3. Raindrops Keep Fallin' On My Head |
| 10-566 | BACK HOME AGAIN (see also John Denver Hits) |
| 7317 | BACK IN THE SADDLE AGAIN |
| 10-506 | BAD, BAD LEROY BROWN |
| | BALI HA'I (see South Pacific) |
| | BALLAD OF JED CLAMPETT (Beverly Hillbillies Theme) (see TV Trivia Set) |
| | BALLIN' THE JACK |
| 8535 | BALTIMORE BUZZ (see also Shuffle Along) |
| 1738 | THE BAND PLAYED ON (waltz) |
| 7406 | BANDANA DAYS (see Shuffle Along) |
| C-101-A | BARCAROLLE (from "Tales of Hoffman") (Offenbach) |
| 612-060-A | BARCAROLLE (Anton Rubinstein) |
| WF-6800 | BARBARA POLKA |
| 9624 | BARNEY GOOGLE |
| 6233 | BASIN STREET BLUES |
| | BATMAN (see TV Trivia Set) |
| | BATTLE HYMN OF THE REPUBLIC |
| | THE BATTLE OF NEW ORLEANS |
| | BE BACK SOON (see Oliver!) |
| | BEALE ST. BLUES (see Tommy Dorsey) |
| | BEAT IT (see Michael Jackson Hits) |
| | BEAT ME DADDY, EIGHT TO THE BAR |
| | BEATLES HITS, Vol. 1 |
| 7324 | 1. Yesterday; 2. Michelle; 3. Penny Lane |
| XP-231-C | BEATLES MEDLEY (played by Marian McPartWood; 3. Eleanor Rigby |
| CEL-180-B | BEAUTIFUL BROWN EYES (waltz) |
| 8715 | BEAUTIFUL DREAMER |
| 6495 | BEAUTIFUL ISLE OF SOMEWHERE (see also Divinity Reflections) |
| 654 | BEAUTIFUL OHIO (waltz) |
| 666 | BECAUSE |
| 117 | BECAUSE OF YOU |
| 8743 | BEE GEES HITS |
| XP-190-C | 1. Jive Talkin'; 2. How Deep Is Your Love; 3. Night Fever |
| 7009 | BEER BARREL POLKA (Roll Out The Barrel) (see also Polka Favorites) |
| CEL-112-A | BEER BARREL POLKA (played by Liberace) |
| | BEFORE THE PARADE PASSES BY (see Hello Dolly!) |
| 6997 | BEGIN THE BEGUINE (fox trot) |
| 10-522 | BEHIND CLOSED DOORS |
| | BEI MIR BISTU SCHOEN (see Andrews Sisters) |
| 10-727 | BELIEVE IT OR NOT (The Greatest American Hero) |
| 1075 | THE BELLS OF ST. MARY'S (see also Bing Crosby Med.) |
| XP-101-B | IRVING BERLIN MEDLEY |
| | 1. Alexander's Ragtime Band; 2. A Pretty Girl Is Like A Melody; 3. Always; 4. Say It Isn't So; 5. Blue Skies |
| 7894 | BESAME MUCHO (Kiss Me Much) (rhumba fox trot) |
| | BESS YOU IS MY WOMAN (see Porgy & Bess) |
| XP-214-B | THE BEST LITTLE WHOREHOUSE IN TEXAS |
| | 1. Twenty Fans; 2. Lil' Ol' Bitty Pissant Country Place; 3. Texas Has A Whorehouse In It; 4. The Aggie Song; 5. The Sidestep; 6. Hard Candy Christmas |
| | THE BEST OF TIMES (see La Cage Aux Folles) |
| 10-736 | BEST THAT YOU CAN DO (Arthur's Theme) |
| 10-724 | BETHENA (see Joplin Rags) |
| | BETTE DAVIS EYES |
| | THE BEVERLY HILLBILLIES (Ballad of Jed Clampett) (see TV Trivia Set) |
| 10-839 | BEVERLY HILLS COP THEME (AXEL F) |
| 8634 | BEWITCHED, BOTHERED & BEWILDERED |
| 9194 | THE BIBLE TELLS ME SO |
| | BICYCLE BUILT FOR TWO (see Daisey, Daisey) |
| 10-267 | LES BICYCLETTES DE BELSIZE |
| XP-249 | BIG CHILL MEDLEY |
| | 1. The Tracks of My Tears; 2. It's The Same Old Song; 3. Dancing In The Street; 4. My Girl; 5. (You Make Me Feel Like) A Natural Woman; 6. When A Man Loves A Woman |
| | BIG SPENDER (see Sweet Charity) |
| 9553 | BILL (see Show Boat) |
| | BILL BAILEY (4-hand arrangement) (see also Favorite Old Timers and Memory Songs) |
| CEL-161-A | BILL BAILEY (played by Peter Duchin) |
| | BILLIE JEAN (see Michael Jackson Hits) |
| Q-181 | BIRTH OF THE BLUES |
| 8825 | BLACK AND WHITE RAG |

3637	BLACK BOTTOM	10-616	CAN'T SMILE WITHOUT YOU (see also Barry Manilow)	XP-138-A	GEO. M. COHAN MEDLEY (pt. 1)	8460	DILL PICKLES RAG (swing version)
9900	BLACK BOTTOM STOMP (Jelly Roll Morton)	10-205	CAN'T TAKE MY EYES OFF OF YOU		1. Yankee Doodle Boy; 2. Mary's A Grand Old Name; 3. Forty-Five Minutes From Broadway; 4. You're A Grand Old Flag		DING DONG, THE WITCH IS DEAD (see Wizard of Oz)
3033	THE BLACK HAWK WALTZ	10-840	CANON IN D (Pachelbel) (from Ordinary People)	XP-139-A	GEO. M. COHAN MEDLEY (pt. 2)	XP-235B	DISNEY CLASSICS
8961	BLESS THIS HOUSE (see also Thanksgiving Medley)	R-245	EL CAPITAN		1. Give My Regards To Broadway; 2. So Long Mary; 3. Harrigan; 4. Over There		1. When You Wish Upon A Star; 2. Mickey Mouse Club March; 3. It's A Small World
3648	BLESSED ASSURANCE	7153	CARELESS	8765	COLD, COLD HEART (see also Hank Williams)	3772	DITES MOI (see South Pacific)
9916	BLOWIN' IN THE WIND	10-828	CARELESS WHISPER		CARINO MIO (see Paint Your Wagon)		DIVINITY REFLECTIONS No. 1
	BLUDDLE-UDDLE-UM-DUM (see Snow White Medley)	5827	CARIOCA (from "Flying Down To Rio") (tango)	XP-223-C	NAT "KING" COLE MEDLEY		1. Beautiful Isle of Somewhere; 2. Lead Kindly Light;
10-698	BLUE BAYOU	9299	CARLE BOOGIE		1. Nature Boy; 2. Mona Lisa; 3. Pretend	3773	DIVINITY REFLECTIONS No. 2
10-340	BLUE CHRISTMAS	C-127-A	CARMEN GRAND POTPOURRI	33-372	COLONEL BOGEY MARCH (River Kwai March)		1. Silent Night; 2. Holy, Holy
3034	BLUE DANUBE WALTZ	XP-207-B	HOAGY CARMICHAEL MEDLEY	3570	COLUMBIA, GEM OF THE OCEAN (see also Statue of Liberty)	202	DIXIE
8848	BLUE HAWAII		1. Stardust; 2. Ole Buttermilk Sky; 3. Lazy Bones; 4. The Nearness of You		COME HITHER YE FAITHFUL (see Around The Christmas Tree)	XP-246C	DIXIELAND CLASSICS 1. That's A Plenty; 2. Midnight In Moscow;
8526	BLUE MOON		CARNIVAL OF THE ANIMALS		COME GO WITH ME (see '57 Rock 'n' Roll)		3. Copenhagen
Q-112	BLUE SKIES (see also Irving Berlin Medley)	XP-155-B	CAROLINA IN THE MORNING		COME SATURDAY MORNING		DIZZY FINGERS
8487	(THE) BLUE SKIRT WALTZ	10-662	CAROLINA MOON	10-388	COME THOU ALMIGHTY KING (see Christmas Medley)		DO NOTHING TILL YOU HEAR FROM ME (see Sophisticated Ladies)
	BLUE SUEDE SHOES (see Elvis Presley, Vol. II)	Q-113	CAROLINA SHOUT		COME TO ME, BEND TO ME (see Brigadoon)	10-169	DO YOU HEAR WHAT I HEAR?
8818	BLUE TANGO	4668	CAROUSEL		COMIN' THRO' THE RYE (see Favorite Dance Medley)	10-219	DO YOU KNOW THE WAY TO SAN JOSE
9931	BLUE VELVET	Q-129	1. Carousel Waltz; 2. June Is Bustin' Out All Over; 3. If I Loved You; 4. A Real Nice Clambake; 5. Mister Snow; 6. What's The Use of Wonderin'; 7. You'll Never Walk Alone		CONCERTO IN A MINOR, Op. 16, First Movement (Grieg)		DO YOU WANT TO KNOW A SECRET (see Stars on 45)
9372	BLUEBERRY HILL	XP-123-B	THE CARPENTERS HITS, Vol. 1	C-118-A	CONCERTO IN B-FLAT MINOR, First Movement (Tchaikowsky)	9722	DO-RE-MI (see also Sound of Music)
7576	BLUES IN THE NIGHT (My Mama Done Told Me)		1. Sing (Sing A Song); 2. Top Of The World; 3. Please Mr. Postman	C-121-A	CONCERTO NO. 2 IN C MINOR, Third Movement (Rachmaninoff)	10-090	DOES YOUR CHEWING GUM LOSE ITS FLAVOR
CEL-146-B	BLUES IN THIRDS (played by Earl "Fatha" Hines)	CEL-153-A	CARRY ME BACK TO OLD VIRGINNY (see Home Minstrel Series)	C-139-A	CONSIDER YOURSELF (see Oliver!)	9833	DOIN' WHAT COMES NATUR'LLY (see Annie Get Your Gun)
	BOABDIL (see Echoes From The Metropolitan Opera House)		THE CASCADES (played by William Bolcom)	6015	THE CONTINENTAL		THE DONKEY SERENADE (fox trot)
10-758	BOBBIE SUE	8272	CASINO ROYALE (see James Bond Themes)	8154	COOL WATER		DON'T BE CRUEL (see '54-'51 Elvis Presley Rock 'n' Roll)
7982	BODY AND SOUL		CAVALLERIA RUSTICANA (see Echoes From The Metropolitan Opera House)	10-630	COPACABANA (AT THE COPA) (see also Barry Manilow)	5688	DON'T BRING LULU
60-590-A	BOLERO (Ravel)		CECILIA (fox trot)	9682	COPENHAGEN (see also Dixieland Classics)	9601	DON'T CRY FOR ME ARGENTINA
XP-240C	BONANZA (Theme) (see TV Trivia Set)		CELL BLOCK TANGO (see Chicago Medley)	CEL-139-A	COTTONTAIL RAG (played by Max Morath)	10-721	DON'T FENCE ME IN
	JAMES BOND HITS		CELLOPHANE (see Chicago Medley)		COUNTRY CLUB RAG (played by William Bolcom)	7993	DON'T GET AROUND MUCH ANYMORE (see Duke Ellington Medley and Sophisticated Ladies)
	1. Nobody Does It Better; 2. Live & Let Die; 3. You Only Live Twice; 4. Casino Royale		C'EST MAGNIFIQUE (see Cole Porter Classics)	7739	COW COW BOOGIE	10-607	DON'T IT MAKE MY BROWN EYES BLUE
CEL-107-A	BOOGIE ON THE SKATER'S WALTZ (Skater's Boogie) (played by JoAnn Castle)	10-094-A	CHANUKAH MELODIES	10-674	COWARD OF THE COUNTY	8910	DON'T LET THE STARS GET IN YOUR EYES
7882	BOOGIE WOOGIE (The Original; Instrumental) (see also Tommy Dorsey)		1. Rock of Ages; 2. The Dreidel Song; 3. Chanukah Song; 4. Who Can Retell?; 5. Sevivon; 6. Rock of Ages (reprise)		CRACKLIN' ROSIE (see Neil Diamond Hits)	Q-135	DON'T MESS WITH ME (played by James P. Johnson)
10-505	BOOGIE WOOGIE BUGLE BOY	10-761	CHARIOTS OF FIRE		CRAZY (see Patsy Cline Medley)	7646	DON'T RAIN ON MY PARADE (see Funny Girl)
10-107	BORN FREE	CEL-192-A	CHARIOTS OF FIRE (played by Ferrante & Teicher)	10-834	CRAZY FOR YOU		DON'T SIT UNDER THE APPLE TREE (see also Andrews Sisters Medley)
CEL-133-A	BORN FREE (played by Roger Williams)	Q-133	CHARLESTON	9143	THE CRAZY OTTO		DON'T TELL MAMA (see Cabaret)
10-851	BORN IN THE USA (see also Bruce Springsteen Hits)	Q-1004	CHARLESTON RAG (played by Eubie Blake)	XP-182-B	BING CROSBY MEDLEY	XP-228-C	TOMMY DORSEY MEDLEY
7876	BORN TO LOSE (fox trot)	Q-114	CHARLIE MY BOY		1. White Christmas; 2. Swingin' On A Star; 3. Where The Blue Of The Night; 4. Bells of St. Mary's		1. I'm Getting Sentimental Over You; 2. Beale St. Blues;
	BOTH REACHED FOR THE GUN (see Chicago Medley)	8822	CHARMAINE (waltz)	8477	CRUISING DOWN THE RIVER (On A Sunday Afternoon)	9938	3. Boogie Woogie (solo)
	THE BOWERY (see Good Old Favorites)	7506	CHATTANOOGA CHOO CHOO (see also Glenn Miller Hits Vol. 2)		CRYIN' IN THE CHAPEL (see Elvis Presley, Vol. III)	CEL-108-A	DOWN AT PAPA JOE'S (Play-Along Roll)
7510	BRAHMS' LULLABY	8603	CHATTANOOGIE SHOE SHINE BOY	CEL-183-A	CHICK COREA'S CRYSTAL SILENCE (played by Marian McPartland)	Q-143	DOWN AT PAPA JOE'S (played by JoAnn Castle)
10-484	BRANDY (YOU'RE A FINE GIRL)	6197	CHEEK TO CHEEK (rhumba fox trot)		LA CUCHARACHA (rhumba)	3164	DOWN BY THE O-HIO
7749	BRAZIL (English & Spanish Lyrics)	10-466	CHERISH	5975	CUDDLE UP A LITTLE CLOSER, LOVEY		DOWN BY THE OLD MILL STREAM
10-780	BREAK IT TO ME GENTLY	9144	CHERRY PINK AND APPLE BLOSSOM	7909	WHITE (rhumba)		DOWN ON MacCONNACHY SQUARE (see Brigadoon)
CEL-143-A	THE BREEZE AND I (played by George Shearing)	9934	CHESTNUTS ROASTING (Christmas Song)	WF-9109	LA CUMPARSITA (tango)		DOWN THE FIELD (Yale) (see Football Favorites)
10-777	BRIAN'S SONG (The Hands of Time)	Q-188	CHICAGO (That Toddling Town)			8770	DOWN YONDER (Ragtime)
10-390	BRIDGE OVER TROUBLED WATERS	XP-191-B	CHICAGO MEDLEY (pt. 1)			10-011	DOWNTOWN
XP-140-B	BRIGADOON		1. And All That Jazz; 2. Funny Honey; 3. Cell Block Tango; 4. When You're Good To Mama; 5. All I Care About Is Love; 6. I Can't Do It Alone; 7. My Own Best Friend	10-482	DADDY DON'T YOU WALK SO FAST	9596	DRAGNET (Theme) (see TV Trivia Set)
	1. I'll Go Home With Bonnie Jean; 2. Down On MacConnachy Square; 3. Heather On The Hill; 4. Almost Like Being In Love; 5. Come To Me, Bend To Me; 6. Waitin' For My Dearie; 7. Jeannie's Packin' Up; 8. There But For You Go I; 9. Brigadoon	XP-192-B	CHICAGO MEDLEY (pt. 2)	8596	DADDY'S LITTLE GIRL (waltz)	8673	DREAM
1515	BRINGIN' IN THE SHEAVES		1. I Know A Girl; 2. Roxie; 3. Cellophane; 4. Class; 5. Razzel Dazzel; 6. Both Reached For The Gun; 7. Nowadays; 8. Honey Rag		DAISEY, DAISEY (see Memory Songs, Old Fashioned Waltzes, and Popular Songs of Other Days)		DREAM A LITTLE DREAM OF ME
Q-216	BROTHER CAN YOU SPARE A DIME	Q-262	CHICKERY CHICK	10-482	DAISEY, DAISEY (see Memory Songs, Old Fashioned Waltzes, and Popular Songs of Other Days)	3310	THE DREIDEL SONG (see Chanukah Melodies)
	BUFFALO GALS (see Square Dance Medley)	10-007	CHIM CHIM CHER-EE (see also Mary Poppins)	5181	DANCES (see Forty-Second Street)		DRINKING SONG (see also The Student Prince)
5719	BUGLE CALL RAG	9339	CHIMES (see Santa Claus Time)		DANCE, TEN; LOOKS: THREE (see A Chorus Line) DANCING (see Hello Dolly! pt. 2)	9817	DRIVE MY CAR (see Stars on 45)
8124	BUMBLE-BEE BOOGIE	10-282	CHINA BOY		DANCING IN THE DARK	CEL-162-B	DU, DU LIEGST MIR IM HERZEN
8685	BUSHEL AND A PECK	9098	CHITTY CHITTY BANG BANG		DANCING IN THE DARK (see Best of Bruce Springsteen)		EDDY DUCHIN MEDLEY (played by Peter Duchin)
	BUT NOT FOR ME (see Gershwin Festival)	9960	CHOPSTICKS (J. L. Cook)	2458	DANCING IN THE DARK (see Best of Bruce Springsteen)		1. Embraceable You; 2. Someone To Watch Over Me;
9373	BUTTON UP YOUR OVERCOAT	CEL-102-A	CHOPSTICKS (Play-Along Roll)		DANCING IN THE STREETS (see Big Chill Medley)	10-497	3. The Man I Love; 4. You're My Everything
8426	BUTTONS AND BOWS (from "Paleface")	XP-177-B	CHOPSTICKS (played by JoAnn Castle)		DANNY BOY (Londonderry Air)		DUELLING BANJOS
7664	BY THE LIGHT OF THE SILV'RY MOON		A CHORUS LINE (pt. 1) Recommended For Adults Only	164	DARKTOWN IS OUT TONIGHT (see Home Minstrel Series)		DUKES OF HAZARD (Good Ol' Boys) (see Waylon & Willie)
10-226	BY THE TIME IT GET TO PHOENIX	Q-252	1. I Hope I Get It; 2. I Can Do That; 3. At The Ballet; 4. Hello Twelve, Hello Thirteen, Hello Love; 5. Nothing A CHORUS LINE (pt. 2)	Q-168	DARKTOWN STRUTTERS BALL		DULCINEA (see Man of LaMancha)
Q-179	BYE BYE BLACKBIRD	447	1. The Music and the Mirror; 2. Dance; Ten; Looks: Three; 3. One; 4. What I Did For Love		DARKTOWN STRUTTERS' BALL (played by Baxter & Kortlander)		
10-058	BYE BYE BLUES	XP-210-B	CHRIST THE LORD IS RISEN TODAY (see Easter Hymn Medley)		DARN THAT DREAM		
	BYE, BYE LOVE (see '57-'62 The Everly Bros. Rock 'n' Roll)		CHRISTMAS MUSIC (see back cover)		THE DAUGHTER OF ROSIE O'GRADY (waltz)	10-775	THEMES FROM E.T.
		Q-223	CHRISTOPHER COLUMBUS (played by 'Fats' Waller)		MAC DAVIS MEDLEY	1539	EASTER HYMN MEDLEY
10-199	CAB DRIVER		THE CHRYSANTHEMUM (see Joplin Rags)		1. Baby Don't Get Hooked On Me; 2. I Believe In Music; 3. It's Hard To Be Humble	5728	1. Holy, Holy; 2. Christ The Lord Is Risen Today; 3. Calvary
10-120	CABARET	963	CHURCH IN THE WILDWOOD	9138	DAVEY CROCKETT		EASTER PARADE (Rythm Ballad)
XP-164-B	CABARET (pt. 1)	2584	CIELITO LINDO	10-480	DAY BY DAY (from "Godspell")	CEL-134-A	EASY STREET (see Annie)
	1. Willkommen; 2. Don't Tell Mama; 3. Perfectly Marvelous; 4. Two Ladies; 5. It Couldn't Please Me More; 6. Tomorrow Belongs To Me; 7. Sitting Pretty		CIRIBIRIBIN (see also Harry James and Favorite Italian Songs)	9895	DAYS OF WINE AND ROSES		EASY WINNERS (Joplin) (played by Max Morath)
XP-165-B	CABARET (pt. 2)	10-827	CITY OF NEW ORLEANS	7736	DAYBREAK ("Grand Canyon Suite") (Grove)	8995	EBB TIDE
	1. If You Could See Her Through My Eyes; 2. Meeskite; 3. Why Should I Wake Up; 4. Married; 5. Cabaret; 6. Finale	Q-280	CIVILIZATION (Bongo, Bongo)	8586	DEAR HEARTS AND GENTLE PEOPLE	10-765	EBONY AND IVORY
XP-220-B	CAGE AUX FOLLES, LA (see La Cage Aux Folles)	8021	CLAIR DE LUNE (popular version)	9639	DECK THE HALL (see also Christmas Greetings)	Q-131	ECCENTRICITY (played by James P. Johnson)
7619	THE CAISSONS GO ROLLING ALONG	C-111-A	CLAIR DE LUNE (classical version)		DEEP IN MY HEART DEAR (see The Student Prince)	20-127-A	ECHOES FROM THE METROPOLITAN OPERA HOUSE
8452	CALIFORNIA (HERE I COME)	7452	CLARINET POLKA (polka-fox trot)	7591	DEEP IN THE HEART OF TEXAS (fox trot)		1. The Prophet; 2. Aida; 3. Cavalleria Rusticana;
10-831	CALIFORNIA GIRLS	10-240	CLASS (see Chicago Medley)	6985	DEEP PURPLE (fox trot)		5. Tannhauser;
9898	CALL ME IRRESPONSIBLE	Q-138	CLASSICAL GAS	10-225	DELILAH		6. Nibelungen;
XP-136-B	CAMELOT		CLEARING HOUSE BLUES	10-509	DELTA DAWN	10-135	7. Pagliacci; 8. William Tell
	1. Camelot; 2. If Ever I Would Leave You; 3. What Do The Simple Folk Do; 4. How To Handle A Woman; 5. Lusty Month of May; 6. I Loved You Once In Silence	XP-243B	CLIMB EV'RY MOUNTAIN (see Sound of Music)	XP-189-C	JOHN DENVER HITS, Vol. 1	C-135-A	EDELWEISS (see also Sound of Music)
9683	CAMPTOWN RACES		PATSY CLINE MEDLEY		1. Back Home Again; 2. Take Me Home, Country Roads; 3. Thank God I'm A Country Boy	C-136-A	EIGHTEEN TWELVE OVERTURE, OP. 49 (pt. 1)
1785	CANADIAN CAPERS		1. Walkin' After Midnight; 2. Sweet Dreams; 3. I Fall To Pieces; 4. Crazy (THEY LONG TO BE) CLOSE TO YOU (see Burt Bacharach Medley)	4034	DESER T SONG		(Tchaikowsky)
9342	CANADIAN SUNSET		CODFISH BALL (see Shirley Temple Hits)	XP-239C	NEIL DIAMOND HITS	Q-151	EIGHTEEN TWELVE OVERTURE, OP. 49 (pt. 2)
9637	CAN-CAN DANCE (Offenbach)				1. Sweet Caroline; 2. Song Sung Blue; 3. Love On The Rocks; 4. Cracklin' Rosie		(Tchaikowsky)
10-478	CANDY MAN			6574	DO YOUR MOTHER COME FROM IRELAND?	10-772	EIGHTEENTH STREET STRUT (played by Thomas 'Fats' Waller)
10-387	CAN'T HELP FALLING IN LOVE			Q-102	DILL PICKLES RAG		EIGHTEENTH VARIATION (from Rhapsody on a Theme by Paganini) (Rachmaninoff)
	CAN'T HELP LOVIN' DAT MAN (see Show Boat)						

10-835 EL PASO
ELEANOR RIGBY (see Beatles Medley)
ELEGANCE (see Hello Dolly!)
CEL-184-B DUKE ELLINGTON MEDLEY (played by Marian McPartland)
1. Don't Get Around Much Anymore;
2. Mood Indigo;
3. Satin Doll; 4. It Don't Mean A Thing If It Ain't Got That Swing
ELMER'S TUNE (fox trot)
ELVIRA (Oak Ridge Boys)
EMBRACEABLE YOU (see also Eddy Duchin Medley)
7303 EMPEROR WALTZ (Strauss)
10-735 ENDLESS LOVE
8601 ENJOY YOURSELF (It's Later Than You Think)
10-518 THE ENTERTAINER ("The Sting") (see also Joplin Medley No. 2 and Joplin Rags from "The Sting")
CEL-138-A THE ENTERTAINER ("The Sting") (played by Max Morath)
10-672 ESCAPE (The Pina Colada Song)
EVENING PRAYER (When At Night I Go To Sleep) (see Christmas Carols and Land of the Christmas Star)
10-583 EVERGREEN (Love Theme From "A Star Is Born")
CEL-177-A EVERGREEN (played by Marian McPartland)
9972 EVERYBODY LOVES SOMEBODY (fox trot)
10-402 EVERYTHING IS BEAUTIFUL
10-790 EVERYTHING OLD IS NEW AGAIN
9317 EXACTLY LIKE YOU
9782 EXODUS
CEL-186-A EXODUS (played by Ferrante & Teicher)

F

10-715 FAME
63-210-A FANTASIE IMPROMPTU OP. 66 (Chopin)
XP-135-B THE FANTASTICKS
1. Overture; 2. Try To Remember;
3. Metaphor (Love, You Are Love);
4. It Depends on What You Pay;
5. Soon It's Gonna Rain; 6. Rode Ballet;
7. I Can See It
3055 FASCINATING RHYTHM (see also Gershwin Medley)
9481 FASCINATION
589 FAVORITE DANCE MEDLEY
1. Old Black Joe; 2. Comin' Thro' the Rye; 3. Rocked In The Cradle Of The Deep;
4. In The Gloaming; 5. When You And I Were Young, Maggie; 6. Love's Old Sweet Song
94-A FAVORITE ITALIAN SONGS
1. Maria Mari; 2. O Sole Mio;
3. Ciribiribin; 4. Funiculi, Funicula
7184 FAVORITE OLD-TIME WALTZES
1. Sunshine of Paradise Alley;
2. She's More To Be Pitied Than Censured; 3. I Don't Want To Play In Your Yard; 4. Absence Makes The Heart Grow Fonder
7177 FAVORITE OLD TIMERS
1. Bill Bailey; 2. Good Morning Carriell;
3. Just Because She made Dem Goo Goo Eyes
10-547 FEELINGS
CEL-187-A FEELINGS (played by Ferrante & Teicher)
10-821 FELIZ NAVIDAD
XP-122-B FIDDLER ON THE ROOF
1. Fiddler On The Roof; 2. Matchmaker;
3. If I Were A Rich Man;
4. Sunrise, Sunset; 5. To Life
10-151 THE 59th ST. BRIDGE SONG (Feelin' Groovy) (see also Simon & Garfunkel)
10-555 50 WAYS TO LEAVE YOUR LOVER
FIG LEAF RAG (see Joplin Medley No. 1)
XP-141-B FINIAN'S RAINBOW
1. If This Isn't Love; 2. How Are Things In Glocca Morra; 3. Old Devil Moon;
4. When I'm Not Near The Girl I Love;
5. Something Sort Of Grandish;
6. Look to the Rainbow;
7. That Great Come And Get It Day
2034-A FIRESIDE SONGS
1. Silver Threads Among The Gold;
2. Love's Sweet Song;
3. Sweetest Story Ever Told;
4. Sweet Adeline;
5. My Old Kentucky Home;
6. Then You'll Remember Me
3319 THE FIRST NOEL
10-475 THE FIRST TIME EVER I SAW YOUR FACE
XP-141-B FINIAN'S RAINBOW
1. If This Isn't Love; 2. How Are Things In Glocca Morra;
3. Old Devil Moon; 4. When I'm Not Near The Girl I Love;
5. Something Sort Of Grandish;
6. Look To The Rainbow;
7. FIVE FOOT TWO, EYES OF BLUE (new arrangement)
10-792 FIVE FOOT TWO, EYES OF BLUE
Q-249 FLASHDANCE... WHAT A FEELING
7956 THE FLAT-FOOT FLOOGEE
9896 THE FLIGHT OF THE BUMBLE-BEE
FLY ME TO THE MOON (In Other Words)
A FOGGY DAY (see Gershwin Festival)
FOOD GLORIOUS FOOD (see Oliver!)
XP-106-A FOOTBALL FAVORITES
1. On Wisconsin; 2. Down The Field (Yale)
10-433 FOR ALL WE KNOW

7750 FOR HE'S A JOLLY GOOD FELLOW (see Happy Birthday)
FOR ME AND MY GAL (played by Frank Milne)
Q-173 FOR ME AND MY GAL (played by Pete Wendling)
10-375 FOR ONCE IN LIFE
10-442 FOR THE GOOD TIMES (see also Ray Price)
10-768 FOR UNTO US A CHILD IS BORN (Handel's "Messiah")
FORTY-FIVE MINUTES FROM BROADWAY (see Geo. M. Cohan Medley)
10-346 FORTY-SECOND STREET
XP-199-B FORTY-SECOND STREET (pt. 1)
1. Shadow Waltz; 2. Shuffle Off To Buffalo; 3. Young and Healthy;
4. Lullaby Of Broadway;
5. Forty-Second Street
XP-202-B FORTY SECOND STREET (pt. 2)
1. We're In The Money;
2. You're Getting To Be A Habit With Me; 3. About A Quarter To Nine;
4. Dames
Q-186 FOUNTAIN IN THE PARK
10-854 (see Popular Songs Of Other Days)
FRANKIE & JOHNNY
FRIENDS & LOVERS
8681 FROM HEAVEN I WAS SENT TO EARTH (see Around The Christmas Tree)
FROSTY THE SNOWMAN
FUN, FUN, FUN (see '62-'67 The Beach Boys Rock 'n' Roll)
FUNICULI FUNICULA (see Favorite Italian Songs)
XP-144-B FUNNY GIRL
1. Overture; 2. Greatest Star; 3. People;
4. You Are Woman; 5. Sadie, Sadie Married Lady; 6. Don't Rain On My Parade
FUNNY HONEY (see Chicago Medley)

G

G.I. BLUES (see Elvis Presley)
8448 GALWAY BAY
10-641 THE GAMBLER (see also Kenny Rodgers Hits)
10-355 GAMES PEOPLE PLAY
XP-248C JUDY GARLAND MEDLEY
1. Zing! Went the Strings of My Heart;
2. You Made Me Love You;
3. Over the Rainbow; 4. Trolley Song
GARY, INDIANA (see Music Man)
XP-250C GEMS FROM GIGI
1. GiGi; 2. The Night They Invented Champagne; 3. I Remember It Well;
4. Thanks Heaven For Little Girls
10-210 GENTLE ON MY MIND
8581 GEORGIA ON MY MIND
XP-108-A GERSHWIN FESTIVAL
1. A Foggy Day; 2. But Not For Me
CEL-121-B GERSHWIN MEDLEY (played by Liberate)
1. Rhapsody In Blue (excerpt);
2. Someone to Watch Over Me;
3. Swanee; 4. The Man I Love;
4973 5. Fascinating Rhythm; 6. I Got Rhythm
GET HAPPY GET ME TO THE CHURCH ON TIME (see My Fair Lady)
9407 GETTING TO KNOW YOU (see also The King & I)
XP-114-A GETTING TO KNOW YOU/I'LL BE SEEING YOU
9825 GIGI (see Gems from GiGi)
8084 GIMME A LITTLE KISS (Will Ya, Huh?)
9975 THE GIRL FROM IPANEMA (Garota De Ipanema)
THE GIRL THAT I MARRY (see Annie Get Your Gun)
9200 GIVE A LITTLE WHISTLE (see Pinocchio)
GIVE MY REGARDS TO BROADWAY (see also Geo M. Cohan Medley)
10-852 THE GLORY OF LOVE (Theme from Karate Kid II)
2591 THE GLOW WORM
8899 THE GLOW WORM (swing version)
GO INTO YOUR DANCE (see Forty-Second Street)
7024 GOD BLESS AMERICA (see also Statue of Liberty) (see also Kate Smith Remembered)
3318 GOD REST YE MERRY GENTLEMEN
WF-183 GOD SAVE THE QUEEN (see also Royal Wedding Commemorative Roll)
10-473 THE GODFATHER (Speak Softly Love)
CEL-111-A THE GODFATHER (Prelude & Love Theme) (played by Liberate)
GOOD KING WINCESLAS (see Christmas Greetings)
4193 A GOOD MAN IS HARD TO FIND
GOOD MORNING, CARRIE (see Favorite Old Timers)
2955 GOOD OL BOYS (Dukes of Hazzard) (see Waylon & Willie)
GOOD OLD FAVORITES
1. The Bowery; 2. In My Merry Oldsmobile; 3. In The Shade Of The Old Apple Tree; 4. Tammany
10-206 THE GOOD, THE BAD, AND THE UGLY
GOODBYE MY CONEY ISLAND BABY (see Memory Songs)
XP-225-C BENNY GOODMAN HITS
1. Gotta Be This Or That;
2. Stompin' At The Savoy;
3. One O'clock Jump
XP-252c BENNY GOODMAN-KING OF SWING
1. Let's Dance; 2. I Got It Bad & That Ain't Good; 3. Sing, Sing, Sing; 3. And The Angels Sing

8649 GOODNIGHT, IRENE GOODNIGHT, LADIES (see Memory Songs)
GOODNIGHT MY SOMEONE (see Music Man)
5230 GOODNIGHT SWEETHEART (see Kate Smith Remembered)
9500 GOODY GOODY
8693 GOOFUS
XP-230-C GOSPEL FAVORITES
1. Put Your Hand In The Hand;
2. He's Got The Whole World In His Hands; 3. On The Jericho Road
GOTTA BE THIS OR THAT (see Benny Goodman)
9018 GRANADA
7736 GRAND CANYON SUITE (Daybreak) (Grove)
10-843 GRANDFATHER'S CLOCK (see Santa Claus Time)
10-285 GRANDMA GOT RUN OVER BY A REINDEER
GREAT BALLS OF FIRE
THE GREAT PRETENDER (see '54-'55 Rock 'n' Roll)
7174 GREAT SPECKLED BIRD
10-727 THE GREATEST AMERICAN HERO (Believe It Or Not)
10-850 THE GREATEST LOVE OF ALL
7394 GREATEST STAR (see Funny Girl)
10-354 GREEN ACRES (Theme) (TV Trivia Set)
CEL-185-A GREEN EYES
GREEN GREEN GRASS OF HOME
GREENSLEEVES (What Child Is This) (played by Ferrante & Teicher)
ANDY GRIFFIN SHOW THEME (The Fishin' Hole) (see TV Trivia Set)
GUESS I'LL HAVE TO TELEGRAPH MY BABY (see Popular Songs Of Other Days)
GYPSY BLUES (see Shuffle Along)
GYPSY LOVE SONG (see Victor Herbert Favorites)
XP-185-B GYPSY MEDLEY
1. Overture; 2. Let Me Entertain You;
3. Some People; 4. Small World;
5. Baby June & Her Newsboys;
6. Mr. Goldstone; 7. Little Lamb;
8. You'll Never Get Away From Me

H

HAIL, HAIL THE GANG'S ALL HERE (see Happy Birthday Medley)
2325 HALLELUJAH CHORUS (from "Messiah")
HAND ME DOWN THAT CAN O' BEANS (see Paint Your Wagon)
10-777 THE HANDS OF TIME (Brian's Song)
8312 HAPPY BIRTHDAY MEDLEY
1. Happy Birthday To You;
2. For He's A Jolly Good Fellow;
3. Hail, Hail The Gang's All Here
4. How Dry I Am; 5. Auld Lang Syne
8312-C HAPPY BIRTHDAY MEDLEY (Deluxe Edition on colorful birthday paper)
4887 HAPPY DAYS ARE HERE AGAIN
10-769 HAPPY HOLIDAY
HAPPY TALK (see South Pacific)
HAPPY TRAILS (Roy Rogers Theme) (see TV Trivia Set)
9052 THE HAPPY WANDERER (Val-De-Ri — Val-De-Ra)
6687 HARBOR LIGHTS
HARD CANDY CHRISTMAS (see Best Little Whorehouse)
2779 HARD HEARTED HANNAH (The Vamp of Savannah)
1516 HARK! THE HERALD ANGELS SING (see also Christmas Hymns and Land Of The Christmas Star)
Q-130 HARLEM STRUT
10-256 HARPER VALLEY P.T.A.
9437 HARRIGAN (see also Geo. M. Cohan Medley)
9943 HAVAH NAGILAH
8199 HAVE I TOLD YOU LATELY THAT I LOVE YOU
5578 HAVE YOU EVER BEEN LONELY?
10-370 HAVE YOURSELF A MERRY LITTLE CHRISTMAS
7232 HAWAIIAN WAR CHANT (TA-HU-WA-HU-WAI)
9659 THE HAWAIIAN WEDDING SONG (Ke Kali Nei Au)
9215 HE
9575 HE'S GOT THE WHOLE WORLD IN HIS HANDS (see also Gospel Favorites)
Q-259 HEART AND SOUL
8311 HEART OF MY HEART (m)
80-139-A HEARTS AND FLOWERS
8213 HEARTACHES
HEARTACHES BY THE NUMBER (see Ray Price Country Favorites)
HEARTBREAK HOTEL (see Elvis Presley)
8856 HEATHER ON THE HILL (see Brigadoon)
CEL-142-A HEAVENLY STRANGER (see Christmas Hymns No. 2)
HEIGH-HO (see Snow White)
7080 HELENA POLKA
HELIOTROPE BOUQUET (see Joplin Rags)
10-809 HELLO (Lionel Richie)
9949 HELLO-DOLLY!
CEL-109-A HELLO, DOLLY! (played by JoAnn Castle)
XP-152-B HELLO DOLLY! (pt. 1)
1. Hello Dolly!; 2. I Put My Hand In;
3. It Takes A Woman;
4. Put On Your Sunday Clothes;

5. Ribbons Down My Back;
6. Motherhood March
HELLO DOLLY! (pt. 2)
1. Dancing; 2. Before The Parade Passes By; 3. Elegance;
4. It Only Takes A Moment; 5. So Long Dearie; 6. Hello Dolly!
XP-120-A HELLO DOLLY/PUT ON A HAPPY FACE
8955 HELLO! MA BABY (Ragtime)
HELLO TWELVE, HELLO THIRTEEN, HELLO LOVE (see A Chorus Line)
HELLO YOUNG LOVERS (see The King And I)
10-469 HELP ME MAKE IT THROUGH THE NIGHT
81-117-A VICTOR HERBERT FAVORITES
1. Kiss Me Again; 2. Gypsy Love Song;
3. Love Is The Best Of All
8449 HERE COMES SANTA CLAUS
21-041-A HERE COMES THE BRIDE (Wedding March from "Lohengrin")
HERE WE COME A-CAROLING (see Christmas Greetings)
10-749 HERE YOU COME AGAIN
9054 HERNANDO'S HIDEAWAY (tango)
HEY, GOOD LOOKIN' (see Hank Williams)
10-257 HEY JUDE
9783 HEY, LOOK ME OVER
9160 HEY, MR. BANJO
10-538 (HEY, WON'T YOU PLAY) ANOTHER SOMEBODY DONE SOMEBODY WRONG SONG
9071 HI-DIDDLE-DEE-DEE (see Pinocchio)
10-245 THE HIGH AND THE MIGHTY
8873 HIGH HOPES
10-738 HIGH NOON (Do Not Forsake Me)
Q-193 THE HILL STREET BLUES THEME
7836 HINDUSTAN
669 HINKY DINKY, PARLEE-VOO
THE HOLY CITY
HOLY, HOLY (see Easter Hymn Medley)
HOLY, HOLY, HOLY (see Christmas Medley and Divinity Reflections No. 2)
HOLY NIGHT (see Around The Christmas Tree and Christmas Hymns No. 2)
XP-168-B HOME MINSTREL SERIES NO. 1
1. Opening Chorus; 2. Darktown Is Out Tonight; 3. Just Break The News To Mother; 4. Lindy; 5. Carry Me Back
XP-169-B To Old Virginy; 6. Is Everybody Happy
HOME MINSTREL SERIES NO. 2
1. Opening Chorus; 2. Lazy Moon;
3. Sweet Adeline; 4. Mirandy;
5. Massa's In The Cold, Cold Ground
5383 HOME ON THE RANGE
10-723 THE HOMECOMING
10-218 HONEY (I Miss You)
HONEY BUN (see South Pacific)
HONEY RAG (see Chicago Medley)
HONEYSUCKLE ROSE (see Ain't Misbehavin')
9358 HONKY TONK
10-816 HOORAY FOR HOLLYWOOD
10-592 HOTEL CALIFORNIA
10-396 HOUSE OF THE RISING SUN
HOW ARE THINGS IN GLOCCA MORRA (see Finian's Rainbow)
HOW COULD RED RIDING HOOD (see Roaring 20's Party Roll)
HOW DEEP IS YOUR LOVE (see Bee Gees Hits)
HOW DRY I AM (see Happy Birthday Medley)
9707 HOW GREAT THOU ART
2725 HOW IRELAND GOT ITS NAME (A Little Bit Of Heaven)
8923 HOW MUCH IS THAT DOGGIE IN THE WINDOW
HOW TO HANDLE A WOMAN (see Camelot)
Q-191 HOW YOU GONNA KEEP 'EM DOWN ON THE FARM?
C-103-A HUMORESQUE, OP. 101 NO. 7 (Dvorak)
C-120-A HUNGARIAN DANCE NO. 5 (Brahms)
10-541 THE HUSTLE

I

I AIN'T GOT NOBODY
8070 I'M ALWAYS CHASING RAINBOWS
6410 I'M AN OLD COWHAND (From The Rio Grande)
I'M BEGINNING TO SEE THE LIGHT (see Sophisticated Ladies)
I'M COMING VIRGINIA
I'M FOREVER BLOWING BUBBLES (waltz)
I'M GETTING SENTIMENTAL OVER YOU (see Tommy Dorsey)
I'M GONNA SIT RIGHT DOWN AND WRITE MYSELF A LETTER
I'M GONNA WASH THAT MAN RIGHT OUTTA MY HAIR (see South Pacific)
8856 I'M IN THE MOOD FOR LOVE
CEL-142-A I'M IN THE MOOD FOR LOVE and SHOULD I (Medley) (played by George Shearing)
I'M JUST WILD ABOUT HARRY (see Shuffle Along)
CEL-127-A I'M JUST WILD ABOUT HARRY (played by Eubie Blake)
8345 I'M LOOKING OVER A FOUR LEAF CLOVER
Q-277 I'M MAKING BELIEVE
I'M ON MY WAY (see Paint Your Wagon)
I'M ONLY THINKING OF HIM (see Man of LaMancha)
9832 I'M POPEYE THE SAILOR MAN (see also TV Trivia Set)

	PILGRIM'S CHORUS (see Thanksgiving Medley)	Q-121	RED HOT MAMA	CEL-164-A	SCRATCH MY BACH (played by Peter Nero)	Q-170	SMILES (There Are Smiles, etc.)
10-672	PINA COLADA SONG (Escape)	4162	RED RIVER VALLEY	7368	SCRUB ME, MAMA, WITH A BOOGIE BEAT	XP-251-C	KATE SMITH REMEMBERED
10-524	PINEAPPLE RAG (see also Joplin Rags from "The Sting")	8475	RED ROSES FOR A BLUE LADY (m)		SEA OF LOVE		1. When the Moon Comes Over The Mtn.; 2. God Bless America;
CEL-156-A	PINEAPPLE RAG (played by William Bolcom)	6244	RED SAILS IN THE SUNSET	10-825	SEA SONGS		3. Marching Along Together;
10-797	THE PINK PANTHER	1478	RED WING	C-119-A	1. Sailing; 2. Starboard Watch;	5808	4. Goodnight Sweetheart
XP-145-B	PINOCCHIO (Medley)	10-158	RELEASE ME (see also Ray Price)		3. Life On The Ocean Wave;	Q-108	SNOKE GETS IN YOUR EYES (fox trot)
	1. When You Wish Upon A Star;	10-476	REMEMBERING YOU (closing theme, "All In The Family")		4. Sailor's Hornpipe;	XP-146-B	SNOW WHITE (Medley)
	2. I've Got No Strings;	8045	REVIEWING THE SITUATION (see Oliver!)		5. Tarpaulin Jacket;		1. Whistle While You Work;
	3. Little Wooden Head;		RHAPSODY IN BLUE (popular theme adaptation) (see also Gershwin Medley)	10-517	6. Asleep In The Deep; 7. Anchored		2. Heigh-Ho; 3. Someday
	4. Turn On The Old Music Box;	C-1005-A	RHAPSODY IN BLUE (pt. 1) (played by George Gershwin)	10-311	SEASONS IN THE SUN (Le Moribond)		My Prince Will Come 4. One Song;
	5. Give A Little Whistle; 6. Hi-Diddle-Dee-Dee	C-1006-A	RHAPSODY IN BLUE (pt. 2) (played by George Gershwin)	1637	SEATTLE		5. With A Smile And A Song;
XP-205-B	THE PIRATES OF PENZANCE (Potpourri)	CEL-123-A	A RHAPSODY IN RAGTIME (played by Eubie Blake)	Q-164	SECOND HAND ROSE (m)	10-410	6. I'm Wishing; 7. Bluddle-Uddle-Um-Dum
C-114-A	PLANTATION SONGS MEDLEY	10-545	RHINESTONE COWBOY	9014	SECOND HAND ROSE (played by Victor Arden)		SNOWBIRD (see also Anne Murray Hits)
	1. Swanee River; 2. My Old Kentucky Home; 3. Old Black Joe; 4. Massa's In De Cold, Cold Ground	8757	RHUMBA BOOGIE	3726	SECRET LOVE		SO LONG DEARIE (see Hello Dolly!)
8648	PLAY A SIMPLE MELODY		RIBBONS DOWN MY BACK (see Hello Dolly!)	10-568	SEMPER FIDELIS (see also March King Medley)	959	SO LONG MARY (see Geo. M. Cohan Medley)
9135	PLEASE DON'T TALK ABOUT ME WHEN I'M GONE	8506	RIDERS IN THE SKY	CEL-181-A	SEND IN THE CLOWNS (played by Marian McPartland)	10-519	SOFTLY AND TENDERLY
	PLEASE MR. POSTMAN (see The Carpenters Hits)	33-372	RIVER KWAI MARCH (Colonel Bogey March)		SENSATION RAG (see Joplin Medley No. 1)		SOLACE (see also Joplin Rags from "The Sting")
20-001-A	POET AND PEASANT OVERTURE (Von Suppe)	XP-233-B	ROARING TWENTIES PARTY ROLL	8019	SENTIMENTAL JOURNEY	10-776	SOLITAIRE
XP-229-C	POLKA MEDLEY		1. Masculine Women, Feminine Men;	8176	SEPTEMBER SONG	8508	SOLITUDE (see Sophisticated Ladies)
	1. Pennsylvania Polka; 2. Beer Barrel Polka; 3. Too Fat Polka;		2. Any Ice Today, Lady;	1736	SERENADE (Schubert)		SOME ENCHANTED EVENING (see also South Pacific)
6305	POLLY WOLLY DOODLE (see also Shirley Temple Hits)	9399	ROCK-A-BYE YOUR BABY WITH A DIXIE MELODY	9563	SERENADE (see The Student Prince)	Q-190	SOME OF THESE DAYS
614-840-A	POLONAISE IN C-SHARP MINOR OP. 26 NO. 1 (Chopin)	9164	ROCK AROUND THE CLOCK	10-051	SEVENTY SIX TROMBONES (see also Music Man)	9674	SOME PEOPLE (see Gypsy Medley)
C-128-A	POLONAISE IN A-FLAT OP. 53 (Chopin)	XP-254-B	'54-'55 ROCK 'n' ROLL		SEVIVON (see Chanukah Melodies)	XP-117-A	SOMEBODY ELSE IS TAKING MY PLACE (m)
8032	POLONAISE OP. 53 (Chopin) (popular version)	XP-256-B	1. The Great Pretender; 3. Sincerely	1545	THE SHADOW OF YOUR SMILE	2473	SOMEBODY ELSE IS TAKING MY PLACE/IF YOU KNEW SUSIE
C-1031-A	POMP AND CIRCUMSTANCE	XP-255-B	'54-'61 ELVIS PRESLEY ROCK 'n' ROLL 1. Jailhouse Rock;	9867	SHALL WE DANCE (see The King And I)		SOMEBODY STOLE MY GAL
172	POOR BUTTERFLY	XP-259-B	2. Don't Be Cruel	5408	SHALL WE GATHER AT THE RIVER		SOMEDAY MY PRINCE WILL COME (see Snow White)
XP-107-B	POPULAR SONGS OF OTHER DAYS	XP-258-B	'57 ROCK 'n' ROLL 1. At The Hop;	9885	SHALOM	10-248	SOMEONE TO WATCH OVER ME (see also Eddy Duchin Medley and Gershwin Medley)
	1. Just One Girl; 2. Sidewalks Of New York; 3. Sweet Rosie O'Grady;	XP-257-B	2. Come Go With Me		SHANTY IN OLD SHANTY TOWN	Q-197	SOMEONE TO WATCH OVER ME (see also Eddy Duchin Medley and Gershwin Medley)
	4. Annie Rooney; 5. Good Old Summertime; 6. Daisey, Daisey (Bicycle Built For Two); 7. Ain't Dat A Shame;	962	'62 ROCK 'n' ROLL	5319	SHANTY IN OLD SHANTY TOWN (m)		SOMETHIN' DOIN' (Joplin)
	8. Fountain In The Park (While Strolling Through The Park);		'62-'67 THE BEACH BOYS ROCK 'n' ROLL 1. Fun, Fun, Fun; 2. Surfer Girl	1775	SHE BELIEVES IN ME (see Kenny Rogers Hits)		SOMETHING'S COMING (see West Side Story)
	9. Guess I'll Have To Telegraph My Baby	10-459	ROCK OF AGES (Cleft For Me)	CEL-101-A	SHE'S MORE TO BE PITTIED THAN CENSURED (see Favorite Old-Time Waltzes)		SOMETHING SORT OF GRANDISH (see Finian's Rainbow)
XP-125-B	PORGY AND BESS	XP-188-C	ROCK OF AGES (see Chanukah Melodies) (see also Sacred Favorites)	8725	SHE'LL BE COMIN AROUND THE MOUNTAIN	10-405	SOMETHING TO REMEMBER YOU BY (see Rudy Vallee Time)
	1. Summertime; 2. I Got Plenty Of Nothin'; 3. My Man's Gone Now;		ROCKED IN THE CRADLE OF THE DEEP (see Favorite Dance Medley)	5206	THE SHEIK OF ARABY		SOMETHING WAS MISSING (see Annie)
	4. Tain't Necessarily So; 5. Bess You Is My Woman		ROCKIN' AROUND THE CHRISTMAS TREE	XP-137-A	THE SHEIK OF ARABY (played by JoAnn Castle)	10-815	SOMETHING WONDERFUL (see The King and I)
XP-245c	COLE PORTER CLASSICS 1. Wundarbar;		KENNY ROGERS HITS VOL. I	10-611	SHENANDOAH WALTZ	10-772	SOMETIMES WHEN WE TOUCH
	2. C'est Magnifique; 3. It's D-Lovely;		1. The Gambler; 2. She Believes In Me;	CEL-142-A	SHINE ON HARVEST MOON	10-090	SOMEWHERE (see West Side Story)
	4. I Love Paris		3. You Decorated My Life	XP-125-B	SHIPS (see Barry Manilow Hits)	CEL-118-A	SOMEWHERE IN TIME (Rachmaninoff)
C-106-A	PRAYER OF THANKSGIVING (see Thanksgiving Medley)	10-326	ROY ROGERS THEME (Happy Trails) (see TV Trivia Set)		SHIRLEY TEMPLE MEDLEY		SOMEWHERE MY LOVE (Lara's Theme)
XP-179-B	PRELUDE IN C-SHARP MINOR OP. 3 (Rachmaninoff)	10-786	ROMEO & JULIET (Love Theme)	10-611	SHORT PEOPLE		SOMEWHERE MY LOVE (played by Liberace)
XP-208-B	ELVIS PRESLEY MEDLEY	10-692	ROSANNA (TOTO)	CEL-142-A	SHOULD I and I'M IN THE MOOD FOR LOVE (medley) (played by George Shearing)	10-479	A SONG OF JOY (Beethoven)
	1. Hound Dog; 2. Love Me Tender;	10-428	THE ROSE	XP-125-B	SHOW BOAT		SONG ON THE SAND (see La Cage Aux Folles)
	3. Jailhouse Rock	9875	ROSE GARDEN		1. Make Believe; 2. Why Do I Love You;		SONG SUNG BLUE (see also Neil Diamond Hits)
XP-209-B	ELVIS PRESLEY, VOL. II	523	ROSES ARE RED (My Love)	3329	3. Bill; 4. Can't Help Lovin' Dat Man;	XP-200-B	SOON IT'S GONNA RAIN (see The Fantasticks)
	"Rockabilly Hits" 1. Heartbreak Hotel;	9668	ROSES OF PICARDY (m)	XP-167-B	5. You Are Love;		SOPHISTICATED LADIES (pt. 1)
	2. G.I. Blues; 3. Blue Suede Shoes		ROW, ROW, ROW		6. Old Man River		1. I'm Beginning To See The Light;
	ELVIS PRESLEY, VOL. III	10-412-A	ROXIE (see Chicago Medley)		SHOW ME THE WAY TO GO HOME	XP-206-B	2. Sophisticated Lady; 3. Don't Get Around Much Anymore; 4. Solitude
	1. It's Now Or Never; 2. Cryin' In The Chapel; 3. Are You Lonesome Tonight?	8580	RUBBER DUCKIE (Rubber Duck Enclosed)		EUBIE BLAKE'S SHUFFLE ALONG		1. I Got It Bad & That Ain't Good;
Q-202	PRETEND (see Nat "King" Cole Medley)	CEL-103-A	RUDOLPH, THE RED-NOSED REINDEER (played by JoAnn Castle)	5596	1. Love Will Find A Way;		2. Do Nothing Till You Hear From Me; 3. I Let A Song Go Out Of My Heart
Q-120	PRETTY BABY (played by Charlie Straight)	Q-267	RUDOLPH, THE RED-NOSED REINDEER (played by JoAnn Castle)	10-046	2. Baltimore Buzz; 3. Bandana Days;	XP-163-B	4. I'm Just Wild About Harry;
6388	PRETTY GIRL IS LIKE A MELODY (see also Irving Berlin Medley)	R-113-A	RUM AND COCA COLA	8422	5. Gypsy Blues	9730	SHUFFLE OFF TO BUFFALO (see also Forty Second St.)
XP-212-B	RAY PRICE COUNTRY FAVORITES		RUSTLE OF SPRING (Singing)	Q-172	SICILIAN TARANTELLA (Fishietando)	XP-129-B	SIDE BY SIDE (fox trot)
	1. For The Good Times; 2. Release Me;				THE SIDESTEP (see Best Little Whorehouse)		THE SIDESTEP (see Best Little Whorehouse)
9401	3. Heartaches By The Number				SIDEWALKS OF NEW YORK (see also Popular Songs of Other Days and Old Fashioned Waltzes)		SIDEWALKS OF NEW YORK/MAKIN' WHOOPEE
	PRISONER OF LOVE	8361	SABRE DANCE (from "Gayne Ballet")	XP-111-A	SILENT NIGHT (see also Christmas Music on back cover)	10-214	SILENT NIGHT
	THE PROPHET (see Echoes From The Metropolitan Opera House)	XP-238-B	SACRED FAVORITES	3317	SILVER BELLS	7096	SILVER BELL
9910	PUFF (THE MAGIC DRAGON)		1. Will The Circle Be Unbroken		SILVER THREADS AMONG THE GOLD (see Fireside Songs)	XP-131-B	SILVER THREADS AMONG THE GOLD
8610	PUT ANOTHER NICKEL IN (MUSIC! MUSIC! MUSIC!)	10-664	2. The Old Rugged Cross; 3. Rock of Ages		SIMON & GARFUNKEL MEDLEY	XP-132-B	SIMON & GARFUNKEL MEDLEY
CEL-105-A	PUT ANOTHER NICKEL IN (played by JoAnn Castle)	10-699	SAD EYES	CEL-193-C	1. Sound of Silence; 2. Fifty-ninth Street Bridge Song (Feelin' Groovy);		1. Sound of Silence; 2. Fifty-ninth Street Bridge Song (Feelin' Groovy);
CEL-170-A	PUT ON A HAPPY FACE (played by Charles Strouse)	10-845	SADIE, SADIE, MARRIED LADY (see Funny Girl)		3. Scarborough Fair; 4. Mrs. Robinson		3. Scarborough Fair; 4. Mrs. Robinson
XP-120-A	PUT ON A HAPPY FACE/HELLO DOLLY PUT ON YOUR SUNDAY CLOTHES (see Hello Dolly!)	10-848	SAILING (Christopher Cross)		FRANK SINATRA MEDLEY		FRANK SINATRA MEDLEY
7846	PUT YOUR ARMS AROUND ME, HONEY (fox trot)	4915	SAILING (see Sea Songs)		1. My Way; 2. New York, New York;		1. My Way; 2. New York, New York;
10-439	PUT YOUR HAND IN THE HAND (see also Gospel Favorites)	4926	SAILOR'S HORNPIPE (see Sea Songs)		3. Strangers In The Night		3. Strangers In The Night
10-277	PUT YOUR HEAD ON MY SHOULDER	Q-166	ST. ELMO'S FIRE		SINCE JESUS CAME INTO MY HEART	9032	SINCE JESUS CAME INTO MY HEART
Q-253	PUTTIN' ON THE RITZ	7971	ST. ELSEWHERE	10-500	SINCERELY (see '54-'55 Rock 'n' Roll)	10-588	SINCERELY (see '54-'55 Rock 'n' Roll)
		CEL-147-C	ST. JAMES INFIRMARY BLUES		SING (Sing A Song) (see also Carpenters' Hits)	8641	SING (Sing A Song) (see also Carpenters' Hits)
			ST. LOUIS BLUES (played by J. L. Cook)		SING ME A SONG OF THE SOUTH (see Magnolia Blossoms)	10-057	SING ME A SONG OF THE SOUTH (see Magnolia Blossoms)
			ST. LOUIS BLUES (played by J. Russel Robinson)		SING, SING, SING (Benny Goodman-King of Swing)	CFL-132-A	SING, SING, SING (Benny Goodman-King of Swing)
			ST. LOUIS BLUES BOOGIE (BOOGIE WOOGIE ON) ST. LOUIS BLUES (played by Earl "Fatha" Hines)	1500	SINGING GAMES	C-109-A	SINGING GAMES
			SAM YOU MADE THE PANTS TOO LONG		1. London Bridges; 2. Itsket, Itsket;	XP-242-A	1. London Bridges; 2. Itsket, Itsket;
			SAN ANTONIO ROSE, NEW		3. Round The Mulberry Bush;		3. Round The Mulberry Bush;
			SAN FRANCISCO (Open Your Golden Gate)		4. The Farmer In The Dell		4. The Farmer In The Dell
			SANTA CLAUS IS COMING TO TOWN (see also Christmas Greetings)	1950-A	SINGIN' IN THE BATHTUB	Q-225	SINGIN' IN THE BATHTUB
			SANTA CLAUS IS COMING TO TOWN (played by JoAnn Castle)		SINGIN' IN THE RAIN	8841	SINGIN' IN THE RAIN
		1553-A	SANTA CLAUS TIME		SISTER KATE (I Wish I Could Shimmy Like My)	2070	SISTER KATE (I Wish I Could Shimmy Like My)
			1. Jingle Bells; 2. O Christmas Tree;		SITTING PRETTY (see Cabaret)		SITTING PRETTY (see Cabaret)
			3. Silent Night; 4. Grandfather's Clock;		SIXTEEN TONS		SIXTEEN TONS
			5. Chimes; 6. Adeste Fidelis;		SITTIN' ON THE DOCK OF THE BAY		SITTIN' ON THE DOCK OF THE BAY
			7. Auld Lang Syne		THE SKATER'S WALTZ		THE SKATER'S WALTZ
		9958	SATIN DOLL (see also Duke Ellington Medley)	10-748	SKATER'S BOOGIE (Boogie On The Skater's Waltz) (played by JoAnn Castle)	10-460	SKATER'S BOOGIE (Boogie On The Skater's Waltz) (played by JoAnn Castle)
		10-806	SAVE THE DANCE FOR ME	10-343	SKYLARK	10-272	SKYLARK
		10-507	SAY, HAS ANYBODY SEEN MY SWEET GYPSY ROSE	4220	SLAUGHTER ON TENTH AVENUE	5139	SLAUGHTER ON TENTH AVENUE
			SAY IT ISN'T SO (see Irving Berlin Medley)	Q-266	SLEEPY TIME GAL	10-583	SLEEPY TIME GAL
		Q-145	SAY IT WITH MUSIC	9315	SLEIGH RIDE (Leroy Anderson)	182	SLEIGH RIDE (Leroy Anderson)
		10-805	SAY SAY SAY	Q-178	SLOW POKE	10-606	SLOW POKE
		10-846	SAY YOU, SAY ME	9283	SMALL WORLD (see Gypsy Medley)		SMALL WORLD (see Gypsy Medley)
		10-211	SCARBOROUGH FAIR/CANTICLE (see also Simon & Garfunkel)	8786			

Q-176	STARS AND STRIPES FOREVER (see also Statue of Liberty)	9614	TAKE MY HAND PRECIOUS LORD	10-813	TIME AFTER TIME		(Theme Adaptation)
Q-244	STARS FELL ON ALABAMA	10-855	TAKE THIS JOB AND SHOVE IT	10-326	A TIME FOR US (Romeo & Juliet)	3038	WASHINGTON POST MARCH (see also March King Med.)
XP-203-A	STARS ON 45 1. Venus; 2. Sugar, Sugar; 3. No Reply; 4. I'll Be Back; 5. Drive My Car; 6. Do You Want To Know A Secret; 7. We Can Work It Out; 8. I Should Have Known Better; 9. Nowhere Man; 10. You're Going To Lose That Girl	10-188	TALES FROM THE VIENNA WOODS (Strauss)	10-514	TIME IN A BOTTLE		WAY DOWN YONDER IN NEW ORLEANS THE WAY WE WERE WAYLON & WILLIE
XP-247c	STARBOARD WATCH (see Sea Songs) STATUE OF LIBERTY 1. America The Beautiful; 2. This Land Is Your Land; 3. God Bless America; 4. Columbia: Gem Of The Ocean; 5. Stars & Stripes Forever	Q-272	TALK TO THE ANIMALS TAMMANY (see Good Old Favorites)	10-126	TINY BUBBLES	Q-127	WE CAN WORK IT OUT (see Stars on 45)
4929	STEIN SONG (Univ. of Maine)	9133	TANNERHAUSER (see Echoes From The Metropolitan Opera House)	Q-199	TIP-TOE THROUGH THE TULIPS	10-516	WE'VE GOT TONIGHT
10-669	STILL	10-046	TARA'S THEME (My Own True Love; Gone With The Wind)	10-808	TO ALL THE GIRLS I'VE LOVED BEFORE TO EACH HIS OWN TO LIFE (see Fiddler On The Roof) TO SIR WITH LOVE TOM DOOLEY	XP-213-B	WE'VE ONLY JUST BEGUN WE'VE ONLY JUST BEGUN (played by Peter Nero)
Q-254	STOMPIN' AT THE SAVOY (see also Benny Goodman)	Q-175	TARANTELLA (Sicilian)	10-178	TOMORROW (see also Annie)	9309	WE NEED A LITTLE CHRISTMAS WE THREE KINGS OF ORIENT ARE (see Christmas Carols)
9530	STOMPIN' AT THE SAVOY (Art Tatum Arr.)	CEL-117-A	TARPAULIN JACKET (see Sea Songs)	9641	TOMORROW BELONGS TO ME (see Cabaret)	Q-275	WE'RE LOYAL TO YOU ILLINOIS WE'RE OFF TO SEE THE WIZARD (see Wizard of Oz)
5618	STORMY WEATHER	9702	TEA FOR TWO (see also No No Nanette)	CEL-191	TOMORROW WILL BE CHRISTMAS DAY (see Around The Christmas Tree)	10-829	WE ARE THE WORLD WE CAN WORK IT OUT (see Stars on 45)
9950	STOUT HEARTED MEN	8689	TEA FOR TWO (played by Liberace)	7538	TONIGHT (see West Side Story)	10-788	WE D'LIKE TO THANK YOU (see Annie)
10-235	STRIKE UP THE BAND FOR UCLA	Q-161	TEA FOR TWO CHA CHA	8321	TONIGHT WE LOVE (Popular Arr. Tchaikovsky Piano Concerto No. 1)	10-422	WEARIN' OF THE GREEN WEDDING MARCH (Mendelssohn)
9290	A STRING OF PEARLS	XP-137-A	TEDDY BEARS' PICNIC	8000	TOO FAT POLKA (see also Polka Medley)	21-041-A	WEDDING MARCH FROM "LOHENGRIIN" (Here Comes The Bride) (Wagner)
9290	A STRING OF PEARLS	9516	TELL ME (Why Nights Are Lonesome)	Q-126	TOO-RA-LOO-RA-LOO-RA	10-778	WEDDING SONG (THERE IS LOVE) (played by Eubie Blake)
9871	THE STRIPPER	8436	SHIRLEY TEMPLE HITS	Q-210	TOOT, TOOT, TOOTSIE	Q-198	WE'LL SING IN THE SUNSHINE WE WISH YOU A MERRY CHRISTMAS (see Christmas Greetings)
612-800-B	THE STUDENT PRINCE 1. Serenade; 2. Drinking Song; 3. Deep In My Heart Dear; 4. Student March Song	9855	SHIRLEY TEMPLE HITS	7167	TOP OF THE WORLD (see Carpenters Hits)	9987	WE'D LIKE TO THANK YOU (see Annie)
Q-214	STUMBLING	10-814	SHIRLEY TEMPLE HITS	10-800	TOP HAT, WHITE TIE & TAILS	284	WE'VE GOT TONIGHT
10-838	SUDDENLY	10-535	SHIRLEY TEMPLE HITS	7221	TORNA A SURRIENTO (Come Back To Sorriento)	9390	WE'VE ONLY JUST BEGUN WE'VE ONLY JUST BEGUN (played by Peter Nero)
5205	SUGAR BLUES (played by J. L. Cook)	9461	SHIRLEY TEMPLE HITS	CEL-124-A	TOTAL ECLIPSE OF THE HEART	10-778	WE'VE ONLY JUST BEGUN WE'VE ONLY JUST BEGUN (played by Peter Nero)
Q-140	SUGAR BLUES	XP-147-A	SHIRLEY TEMPLE HITS	9349	TOYLAND (see also Christmas Greetings)	Q-198	WE'VE ONLY JUST BEGUN WE'VE ONLY JUST BEGUN (played by Peter Nero)
10-791	SUGAR, SUGAR (see Stars On 45)	8923	SHIRLEY TEMPLE HITS	10-783	THE TRACKS OF MY TEARS (see Big Chill Medley)	9390	WE'VE ONLY JUST BEGUN WE'VE ONLY JUST BEGUN (played by Peter Nero)
10-455	SUICIDE IS PAINLESS (song from M*A*S*H)	10-802	SHIRLEY TEMPLE HITS	10-072	TRAUMEREI OP. 15 (Schumann)	21-041-A	WE'VE ONLY JUST BEGUN WE'VE ONLY JUST BEGUN (played by Peter Nero)
CEL-167-A	SUMMER OF '42 THEME (The Summer Knows)	10-853	SHIRLEY TEMPLE HITS	9349	THE TROLLEY SONG (Clang, Clang, Clang)	10-778	WE'VE ONLY JUST BEGUN WE'VE ONLY JUST BEGUN (played by Peter Nero)
9733	SUMMER OF '42 THEME (played by Peter Nero)	10-847	SHIRLEY TEMPLE HITS	10-783	TROUBLESOME IVORIES (played by Eubie Blake)	Q-198	WE'VE ONLY JUST BEGUN WE'VE ONLY JUST BEGUN (played by Peter Nero)
9100	SUMMERTIME (see also Porgy & Bess)	9189	SHIRLEY TEMPLE HITS	10-072	TROUBLESOME IVORIES (played by Eubie Blake)	9390	WE'VE ONLY JUST BEGUN WE'VE ONLY JUST BEGUN (played by Peter Nero)
CEL-169-A	SUNDAY IN NEW YORK (played by Peter Nero)	Q-165	SHIRLEY TEMPLE HITS	10-072	TRUE LOVE (waltz)	21-041-A	WE'VE ONLY JUST BEGUN WE'VE ONLY JUST BEGUN (played by Peter Nero)
Q-1009	SUNNY SIDE UP (Keep Your)	5421	SHIRLEY TEMPLE HITS	10-072	TRY TO REMEMBER (see also The Fantasticks)	10-778	WE'VE ONLY JUST BEGUN WE'VE ONLY JUST BEGUN (played by Peter Nero)
7031	SUNRISE SERENADE (fox trot) (see also Glenn Miller, Vol. 3)	10-223	SHIRLEY TEMPLE HITS	10-072	TRYIN' TO GET THE FEELING AGAIN (see Barry Manilow Hits)	Q-198	WE'VE ONLY JUST BEGUN WE'VE ONLY JUST BEGUN (played by Peter Nero)
10-023	SUNRISE, SUNSET (see also Fiddler On The Roof)	Q-124	SHIRLEY TEMPLE HITS	10-072	TUMBLING TUMBLEWEEDS	965	WE'VE ONLY JUST BEGUN WE'VE ONLY JUST BEGUN (played by Peter Nero)
10-437	SUNSHINE OF PARADISE ALLEY (see Favorite Old-Time Waltzes)	6042	SHIRLEY TEMPLE HITS	10-072	TURKEY IN THE STRAW (see also Square Dance Medley and Magnolia Blossoms)	CEL-185-A	WE'VE ONLY JUST BEGUN WE'VE ONLY JUST BEGUN (played by Peter Nero)
Q-1007	SUPERSTAR (Jesus Christ Superstar)	10-778	SHIRLEY TEMPLE HITS	10-072	TURN ON THE OLD MUSIC BOX (see Pinnocchio)	10-824	WE'VE ONLY JUST BEGUN WE'VE ONLY JUST BEGUN (played by Peter Nero)
Q-122	SURFER GIRL (see '62-'67 The Beach Boys Rock'n' Roll)	9204	SHIRLEY TEMPLE HITS	10-072	TUXEDO JUNCTION (see Glenn Miller)	10-576	WE'VE ONLY JUST BEGUN WE'VE ONLY JUST BEGUN (played by Peter Nero)
751	SWANEE (played by composer, George Gershwin)	241	SHIRLEY TEMPLE HITS	10-072	'Twas THE NIGHT BEFORE CHRISTMAS	Q-278	WE'VE ONLY JUST BEGUN WE'VE ONLY JUST BEGUN (played by Peter Nero)
1524	SWANEE (played by Max Korlander) (see also Gershwin Medley and Al Jolson Hits)	999	SHIRLEY TEMPLE HITS	10-072	TWELFTH STREET RAG (played by Max Kortlander)	9886	WE'VE ONLY JUST BEGUN WE'VE ONLY JUST BEGUN (played by Peter Nero)
10-690	SWANEE RIVER (Old Folks At Home) (see Magnolia Blossoms, Plantation Songs, and Square Dance Med.)	8778	SHIRLEY TEMPLE HITS	10-072	TWELFTH STREET RAG (played by J. L. Cook)	10-376	WE'VE ONLY JUST BEGUN WE'VE ONLY JUST BEGUN (played by Peter Nero)
XP-150-B	SWEET ADELIN (see also Fireside Songs & Home Minstrel Series)	9261	SHIRLEY TEMPLE HITS	10-072	TWELFTH STREET RAG (played by Liberace)	8356	WE'VE ONLY JUST BEGUN WE'VE ONLY JUST BEGUN (played by Peter Nero)
Q-177	SWEET BY AND BY	9261	SHIRLEY TEMPLE HITS	10-072	TWELVE DAYS OF CHRISTMAS TWENTY FANS (see Best Little Whorehouse)	9328	WE'VE ONLY JUST BEGUN WE'VE ONLY JUST BEGUN (played by Peter Nero)
XP-112-A	SWEET CAROLINE (see also Neil Diamond Hits)	8778	SHIRLEY TEMPLE HITS	10-072	TWILIGHT TIME (fox trot)	8356	WE'VE ONLY JUST BEGUN WE'VE ONLY JUST BEGUN (played by Peter Nero)
1594	SWEET CHARITY	9261	SHIRLEY TEMPLE HITS	10-072	THE TWIST	9328	WE'VE ONLY JUST BEGUN WE'VE ONLY JUST BEGUN (played by Peter Nero)
6598	1. Sweet Charity;	Q-256	SHIRLEY TEMPLE HITS	10-072	TWIST & SHOUT (see '62 Rock 'n' Roll)	9328	WE'VE ONLY JUST BEGUN WE'VE ONLY JUST BEGUN (played by Peter Nero)
7960	2. If My Friends Could See Me Now; 3. Big Spender; 4. I Love To Cry At Weddings; 5. There's Gotta Be Something Better; 6. Where Am I Going	10-614	SHIRLEY TEMPLE HITS	10-072	TWO GUITARS	9328	WE'VE ONLY JUST BEGUN WE'VE ONLY JUST BEGUN (played by Peter Nero)
Q-177	SWEET DREAMS (see also Patsy Cline Medley)	8616	SHIRLEY TEMPLE HITS	10-072	TWO LADIES (see Cabaret)	9328	WE'VE ONLY JUST BEGUN WE'VE ONLY JUST BEGUN (played by Peter Nero)
XP-112-A	SWEET GEORGIA BROWN	10-233	SHIRLEY TEMPLE HITS	10-072	TWO LITTLE GIRLS IN BLUE (see Old Fashioned Waltzes)	9328	WE'VE ONLY JUST BEGUN WE'VE ONLY JUST BEGUN (played by Peter Nero)
1594	SWEET GEORGIA BROWN/IT HAD TO BE YOU	10-679	SHIRLEY TEMPLE HITS	10-072	TWO SLEEPY PEOPLE	9328	WE'VE ONLY JUST BEGUN WE'VE ONLY JUST BEGUN (played by Peter Nero)
6598	SWEET HOUR OF PRAYER	9075	SHIRLEY TEMPLE HITS	10-072	UNCHAINED MELODY	9328	WE'VE ONLY JUST BEGUN WE'VE ONLY JUST BEGUN (played by Peter Nero)
7960	SWEET LILIAN (Lay-lah-nee) (fox trot)	10-837	SHIRLEY TEMPLE HITS	10-072	UNDER THE DOUBLE EAGLE	9328	WE'VE ONLY JUST BEGUN WE'VE ONLY JUST BEGUN (played by Peter Nero)
Q-177	SWEET LORRAINE (Art Tatum Arrangement)	10-260	SHIRLEY TEMPLE HITS	10-072	UNFINISHED SYMPHONY NO. 8 IN B MINOR (Schubert)	9328	WE'VE ONLY JUST BEGUN WE'VE ONLY JUST BEGUN (played by Peter Nero)
XP-112-A	SWEET ROSIE O'GRADY (see Old Fashioned Waltzes and Popular Songs of Other Days)	10-467	SHIRLEY TEMPLE HITS	10-072	UNFORGETTABLE	9328	WE'VE ONLY JUST BEGUN WE'VE ONLY JUST BEGUN (played by Peter Nero)
7405	SWEETEST STORY EVER TOLD (see Fireside Songs)	CEL-176-A	SHIRLEY TEMPLE HITS	10-072	THE UNICORN	9328	WE'VE ONLY JUST BEGUN WE'VE ONLY JUST BEGUN (played by Peter Nero)
10-740	SWEETHEART WALTZ (Strauss)	9053	SHIRLEY TEMPLE HITS	10-072	UNIVERSITY OF MAINE (Stein Song) (see also Rudy Vallee Time)	9328	WE'VE ONLY JUST BEGUN WE'VE ONLY JUST BEGUN (played by Peter Nero)
1256	THE SWEETEST THING (I'VE EVER KNOWN)	Q-238	SHIRLEY TEMPLE HITS	10-072	UP IN A BALLOON (see Memory Songs)	9328	WE'VE ONLY JUST BEGUN WE'VE ONLY JUST BEGUN (played by Peter Nero)
1259	SWING LOW, SWEET CHARIOT	10-233	SHIRLEY TEMPLE HITS	10-072	UP ON THE HOUSE TOP	9328	WE'VE ONLY JUST BEGUN WE'VE ONLY JUST BEGUN (played by Peter Nero)
7943	SWING MEDLEY NURSERY RHYMES 1. Farmer In The Dell; 2. Mary Had A Little Lamb; 3. Twinkle, Twinkle Little Star	10-679	SHIRLEY TEMPLE HITS	10-072	UP, UP AND AWAY	9328	WE'VE ONLY JUST BEGUN WE'VE ONLY JUST BEGUN (played by Peter Nero)
Q-177	SWINGING ON A STAR (see also Bing Crosby)	10-773	SHIRLEY TEMPLE HITS	10-072	UP WHERE WE BELONG	9328	WE'VE ONLY JUST BEGUN WE'VE ONLY JUST BEGUN (played by Peter Nero)
2270	TAIN'T NECESSARILY SO (see Porgy & Bess)	10-759	SHIRLEY TEMPLE HITS	10-072	UPTOWN GIRL (see also Billy Joel Hits)	9328	WE'VE ONLY JUST BEGUN WE'VE ONLY JUST BEGUN (played by Peter Nero)
10-810	'TAINT NOBODY'S BIZNESS IF I DO (see also Ain't Misbehavin')	9620	SHIRLEY TEMPLE HITS	10-072	RUDY VALLEE TIME 1. My Time Is Your Time; 2. Something To Remember You By; 3. U Of Maine Stein Song; 4. Whiffenpoof Song (Yale)	9328	WE'VE ONLY JUST BEGUN WE'VE ONLY JUST BEGUN (played by Peter Nero)
10-453	TAKE A LOOK AT ME NOW (Against All Odds)	8656	SHIRLEY TEMPLE HITS	10-072	THE VARSITY DRAG	9328	WE'VE ONLY JUST BEGUN WE'VE ONLY JUST BEGUN (played by Peter Nero)
10-857	TAKE ME HOME, COUNTRY ROADS (see also John Denver Hits)	7979	SHIRLEY TEMPLE HITS	10-072	VAYA CON DIOS (May God Be With You)	9328	WE'VE ONLY JUST BEGUN WE'VE ONLY JUST BEGUN (played by Peter Nero)
8720	TAKE MY BREATH AWAY (Theme from Top Gun)	10-501	SHIRLEY TEMPLE HITS	10-072	VENUS (see Stars on 45)	9328	WE'VE ONLY JUST BEGUN WE'VE ONLY JUST BEGUN (played by Peter Nero)
	TAKE ME OUT TO THE BALL GAME	CEL-129-A	SHIRLEY TEMPLE HITS	10-072	VENUS	9328	WE'VE ONLY JUST BEGUN WE'VE ONLY JUST BEGUN (played by Peter Nero)
		5353	SHIRLEY TEMPLE HITS	10-072	THE VERY THOUGHT OF YOU	9328	WE'VE ONLY JUST BEGUN WE'VE ONLY JUST BEGUN (played by Peter Nero)
		8912	SHIRLEY TEMPLE HITS	10-072	THE VICTORS (U OF M)	9328	WE'VE ONLY JUST BEGUN WE'VE ONLY JUST BEGUN (played by Peter Nero)
		8040	SHIRLEY TEMPLE HITS	10-072	LA VIE EN ROSE	9328	WE'VE ONLY JUST BEGUN WE'VE ONLY JUST BEGUN (played by Peter Nero)
		645	SHIRLEY TEMPLE HITS	10-072	VIENNA LIFE (Wiener Blut)	9328	WE'VE ONLY JUST BEGUN WE'VE ONLY JUST BEGUN (played by Peter Nero)
			SHIRLEY TEMPLE HITS	10-072	VIRGINIA REEL	9328	WE'VE ONLY JUST BEGUN WE'VE ONLY JUST BEGUN (played by Peter Nero)
			SHIRLEY TEMPLE HITS	10-072	VOLARE (Vo-lah-ray)	9328	WE'VE ONLY JUST BEGUN WE'VE ONLY JUST BEGUN (played by Peter Nero)
			SHIRLEY TEMPLE HITS	10-072	WABASH BLUES	9328	WE'VE ONLY JUST BEGUN WE'VE ONLY JUST BEGUN (played by Peter Nero)
			SHIRLEY TEMPLE HITS	10-072	WABASH CANNON BALL	9328	WE'VE ONLY JUST BEGUN WE'VE ONLY JUST BEGUN (played by Peter Nero)
			SHIRLEY TEMPLE HITS	10-072	WAIT TILL THE SUN SHINES NELLIE (fox trot)	9328	WE'VE ONLY JUST BEGUN WE'VE ONLY JUST BEGUN (played by Peter Nero)
			SHIRLEY TEMPLE HITS	10-072	WAITIN' FOR MY DEARIE (see Brigadoon)	9328	WE'VE ONLY JUST BEGUN WE'VE ONLY JUST BEGUN (played by Peter Nero)
			SHIRLEY TEMPLE HITS	10-072	WAITING FOR THE ROBERT E. LEE	9328	WE'VE ONLY JUST BEGUN WE'VE ONLY JUST BEGUN (played by Peter Nero)
			SHIRLEY TEMPLE HITS	10-072	WAKE ME UP BEFORE YOU GO GO	9328	WE'VE ONLY JUST BEGUN WE'VE ONLY JUST BEGUN (played by Peter Nero)
			SHIRLEY TEMPLE HITS	10-072	WALKIN' AFTER MIDNIGHT (see Patsy Cline Medley)	9328	WE'VE ONLY JUST BEGUN WE'VE ONLY JUST BEGUN (played by Peter Nero)
			SHIRLEY TEMPLE HITS	10-072	WALKING THE FLOOR OVER YOU (fox trot)	9328	WE'VE ONLY JUST BEGUN WE'VE ONLY JUST BEGUN (played by Peter Nero)
			SHIRLEY TEMPLE HITS	10-072	THE WALTZ YOU SAVED FOR ME	9328	WE'VE ONLY JUST BEGUN WE'VE ONLY JUST BEGUN (played by Peter Nero)
			SHIRLEY TEMPLE HITS	10-072	WALTZING MATILDA	9328	WE'VE ONLY JUST BEGUN WE'VE ONLY JUST BEGUN (played by Peter Nero)
			SHIRLEY TEMPLE HITS	10-072	WARSAW CONCERTO	9328	WE'VE ONLY JUST BEGUN WE'VE ONLY JUST BEGUN (played by Peter Nero)

9756 CEL-114-A	WHITE CHRISTMAS (Modern Arr.) WHITE CHRISTMAS MEDLEY (played by Liberace) WHO CAN RETELL? (see Chanukah Melodies) WHO DO YOU LOVE I HOPE (see Annie Get Your Gun)	XP-217-B	THE WIZARD OF OZ 1. Over The Rainbow; 2. Munchkin Land; 3. Ding-Dong! The Witch Is Dead; 4. Lullaby League & Lollipop Guild; 5. We're Off To See The Wizard; 6. If I Only Had A Brain; 7. The Merry Old Land Of Oz	2272 10-056 10-347 7955	YES! WE HAVE NO BANANAS YESTERDAY (see also Beatles Hits) YESTERDAY WHEN I WAS YOUNG YOU ALWAYS HURT THE ONE YOU LOVE	7574	YOU MADE ME LOVE YOU (fox trot) (see also Judy Garland Medley) (You Make Me Feel Like) A NATURAL WOMAN (see Big Chill Medley) YOU MUST HAVE BEEN A BEAUTIFUL BABY
Q-215 Q-174 9127	WHO'S AFRAID OF THE BIG BAD WOLF? WHO'S SORRY NOW WHO THREW THE OVERALLS IN MRS. MURPHY'S CHOWDER?	9882	WOLVERTON MOUNTAIN A WONDERFUL GUY (see South Pacific) WOODCHOPPER'S BALL WOODY WOODPECKER	Q-211	YOU'RE A GRAND OLD FLAG (see also Geo. M. Cohan Medley) YOU'RE AN OLD SMOOTHIE YOU'RE GETTING TO BE A HABIT WITH ME (see Forty-Second Street) YOU'RE GOING TO LOSE THAT GIRL (see Stars on 45)	9679 10-635	YOU NEEDED ME (see also Anne Murray Hits) YOU ONLY LIVE TWICE (see James Bond Themes) YOU TELL ME YOUR DREAM, I'LL TELL YOU MINE (see Memory Songs) YOU WERE MEANT FOR ME (fox trot) YOU'LL NEVER GET AWAY FROM ME (see Gypsy Med.)
9293	WHO WILL BUY (see Oliver!) WHY DO FOOLS FALL IN LOVE? WHY DO I LOVE YOU (see Show Boat) WHY SHOULD I WAKE UP (see Cabaret)	8146 Q-273 8777	WORLD IS WAITING FOR THE SUNRISE (Swing Arr.) WOULDN'T IT BE LOVERLY (see My Fair Lady)	Q-245 7258	YOU'RE JUST IN LOVE (see Ethel Merman Medley) YOU ARE LOVE (see Show Boat) YOU'RE MY EVERYTHING (see Eddy Duchin Medley)	8369	YOU'LL NEVER KNOW YOU'LL NEVER WALK ALONE (see also Carousel)
7028	WIENER BLUT (Vienna Life)	Q-234	WRAP YOUR TROUBLES IN DREAMS WUNDERBAR (see Cole Porter Classics)	9850	YOU ARE MY LUCKY STAR YOU ARE MY SUNSHINE (fox trot) YOU'RE NEVER REALLY DRESSED WITHOUT A SMILE (see Annie)	9330 8880	YOU'LL NEVER KNOW YOU'LL NEVER WALK ALONE (see also Carousel) YOU WON'T BE AN ORPHAN FOR LONG (see Annie) YOUNG AND HEALTHY (see Forty-Second Street)
2839	WILKOMMEN (see Cabaret)			9564 10-753	YOU'RE NOBODY 'TIL SOMEBODY LOVES YOU YOU'RE THE CREAM IN MY COFFEE YOU'RE THE REASON GOD MADE OKLAHOMA	10-528 9636	THE YOUNG AND THE RESTLESS YOUNG LOVE YOUNGER THAN SPRINGTIME (see South Pacific)
90-124-A	WILLIAM TELL OVERTURE (see also Echoes From The Metropolitan Opera House)			10-737	YOU ARE THE SUNSHINE OF MY LIFE YOU ARE WOMAN (see Funny Girl) YOU CAN DANCE WITH ANY GIRL AT ALL (see No No Nanette)	8938	YOUR CHEATIN' HEART (see also Hank Williams)
XP-211-B	HANK WILLIAMS COUNTRY FAVORITES 1. Cold Cold Heart; 2. Your Cheatin' Heart; 3. Hey Good Lookin'			8377 10-677	YOU DECORATED MY LIFE (see also Kenny Rogers Hits)	6155 7426 244	YOUR FEET'S TOO BIG YOURS (rhumba) YULETIDE SONG MEDLEY 1. Silent Night; 2. Jingle Bells; 3. O Joy To Us; 4. Auld Lang Syne
Q-257 10-116 10-308 9796 6043	WILLOW WEEP FOR ME WINCHESTER CATHEDRAL THE WINDMILLS OF YOUR MIND WINGS OF A DOVE WINTER WONDERLAND WITH A LITTLE BIT OF LUCK (see My Fair Lady)	10-703 223 7681	XANADU YANKEE DOODLE/WHEN JOHNNY COMES MARCHING HOME YANKEE DOODLE BOY (see also Geo. M. Cohan Medley)	10-636 Q-110	YOU DON'T BRING ME FLOWERS YOU'VE GOT TO SEE MAMA EV'RY NIGHT	8184 10-297	ZORBA THEME (LIFE IS)
8847	WITH A SONG IN MY HEART WITH A SMILE AND A SONG (see Snow White) WITH YOU ON MY ARM (see La Cage Aux Folles)	9823 7125 9193 CEL-106-A 9035	YELLOW BIRD (see also Mills Brothers) THE YELLOW ROSE OF TEXAS THE YELLOW ROSE OF TEXAS (Modern Arr.) THE YELLOW ROSE OF TEXAS (played by JoAnn Castle) YES SIR, THAT'S MY BABY	10-603	YOU LIGHT UP MY LIFE		

Will my piano play Q-R-S Rolls?

No one is quite sure when the player piano was invented or just who invented it. But we do know that for over eighty-five years, player pianos and Q-R-S Player Rolls have entertained, mystified, and delighted people of all ages.

Early player pianos used a special 65-note roll with perforations spaced six to the horizontal inch. Q-R-S has not issued this type of roll in nearly 60 years! The name "Pianola" was once a trade-mark name for a specific brand of these early machines and their 88-note successors, but the term has become a generic one, applied to all player pianos.

The 88-note player as we know it today was developed by Q-R-S founder Melville Clark in 1901. It was accepted as the national standard in 1908, and all players made since that time will play Q-R-S Player Rolls. Our perforations are spaced nine to the horizontal inch.

Kimball players made in recent years cannot play rolls on large spools. The catalog numbers of these rolls are underlined in this catalog. You can divide these rolls into two shorter rolls with supplies found in the Roll Repair Kit listed under Professional Roll Repair Parts in this catalog.

What is a reproducing piano?

Several brands of very sophisticated mechanical pianos were sold in the 1920's and 30's. They were called "reproducing pianos", because they could reproduce the playing of a human pianist with amazing fidelity. The leading brands in the U.S. were Ampico, Welte, and Duo-Art (not to be confused with Duo/Art players made since the 1950's). All three brands of reproducing piano play Q-R-S rolls in addition to their own specially-coded rolls. Send a self-addressed, stamped envelope for a complete listing of Q-R-S reissues of rare Ampico and Duo-Art rolls. Test rolls and service manuals are listed in the Accessory category of this catalog.

What is an expression piano?

Somewhere between the straight-forward player piano and the complex reproducing piano comes the "expression piano", of which the Recordo is the most frequently encountered today. Pianos installed with the Recordo expression system can be identified by the five slotted holes at each end of the tracker bar. These pianos, dating mostly from the 1920's, play Q-R-S Rolls in addition to their own special Recordo rolls. Send a self-addressed, stamped envelope for a complete listing of original Recordo rolls.

Is there a right way to play rolls?

First, see that the music roll is loosely wound on the spool. Then hold it in the hand with the SLOTTED end down. Let the roll drop lightly two or three times against a hard surface, thus throwing the entire music sheet against the right flange of the spool. The roll is now ready to play. **DO NOT TIGHTEN ROLL!**

On your player piano, the brass bar with a row of holes is called the "tracker bar". A roll will play properly only if the holes in the roll align with the holes in the tracker bar. This process is called "tracking". Most players are equipped with an automatic tracker to assure that rolls track properly. Older players which lack automatic trackers must be adjusted manually during play.

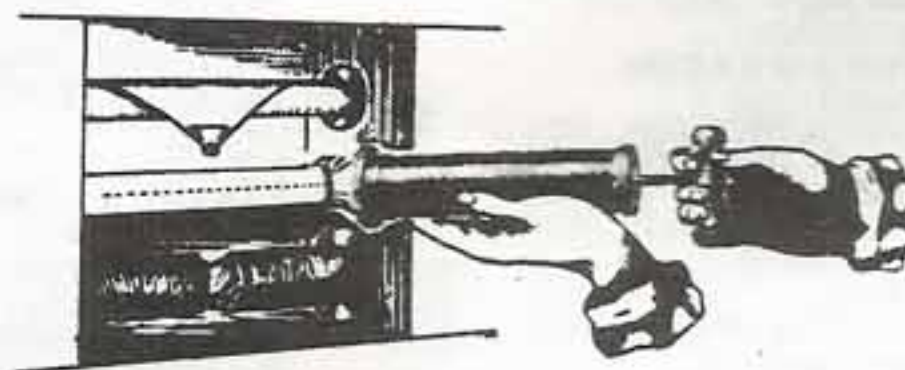

One type of automatic tracker uses "feelers" that ride along the roll's edges during play. The other type uses small air holes at the extreme ends of the tracker bar. Both types will malfunction if the roll edges are torn. The air-hole type can become clogged with dust and fail to track. Use a Tracker Bar Pump to draw dust out of any clogged air holes.

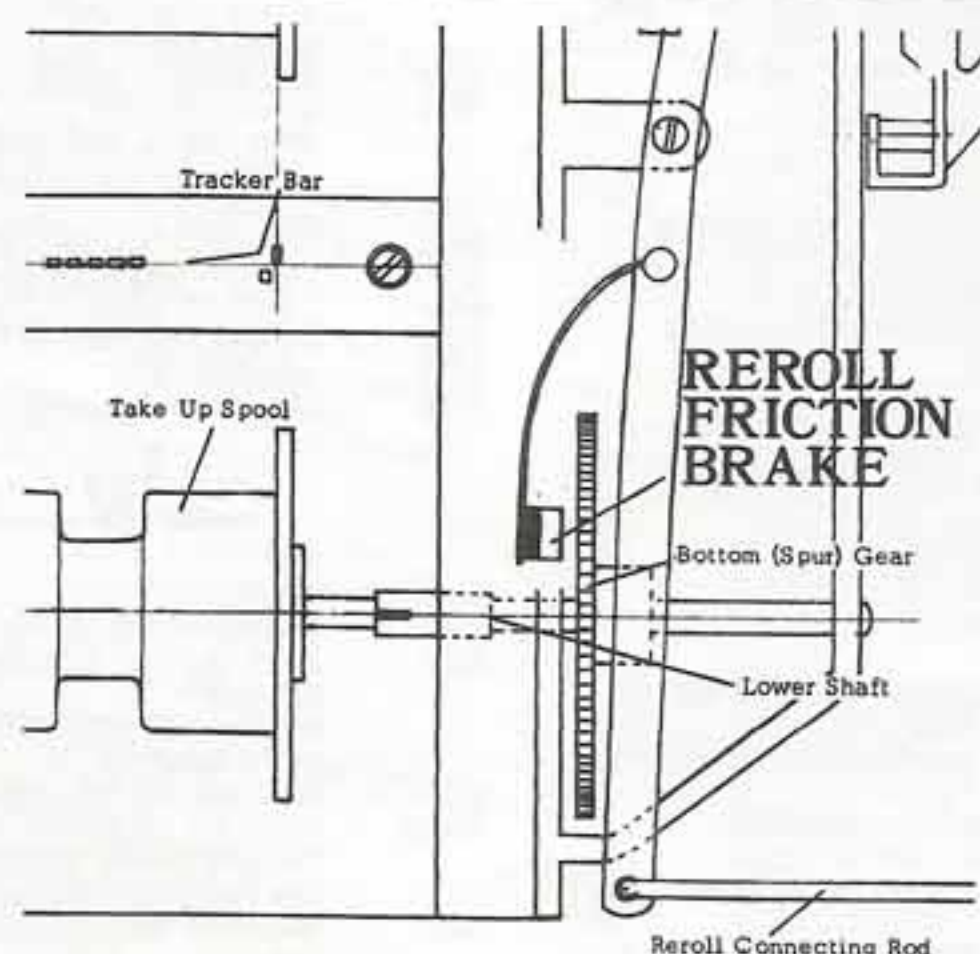

How can I repair old rolls?

Favorite old rolls sometimes tear along the edge. They can be easily repaired with Scotch Magic Transparent Tape. Important: Place the tape on both the right and left edge, even if only one is torn. This will create an even build-up on the spools and equalize tension on the paper as it passes over the tracker bar. Always place tape on the surface of the roll which faces you when playing—never on the back. Do not use masking tape, plastic tape, etc., as these will ruin the roll.

The skeleton of the piano roll is called the "spool assembly". It consists of a cardboard tube and two plastic flanges. The right-hand flange has a slot it and is called the "drive" flange. The one on the left has no slot and is called the "idler" flange.

Replacement parts for all of the above, as well as spare roll boxes, are listed under "Professional Roll Repair Parts" in this catalog.

What kind of paper do you use?

The paper now used in Q-R-S rolls is the best we've ever had in all our years in business. It is strong; it tracks very well; lyrics look sharp; and it perforates cleanly. Best of all, its thinness makes it possible to spool longer rolls than ever before! We love the good old days; but some things are much better in the present.

How does Q-R-S select new music?

We use national music statistics and try to select music that will please the majority of our customers. If we missed one of your favorites, please let us know! We need your input to insure your complete satisfaction.

Q-R-S OLD ROLL AUCTION

Send self-addressed, stamped envelope for full details.

Q-R-S MUSIC ROLLS
1026 Niagara St., Buffalo, NY 14213

Q-R-S Reproducing Rolls

Recordo

NOTICE: If you do not have a Recordo piano but wish to play Recordo rolls, please see explanation below.

M-614-080-A	AVE MARIA (Schubert-Liszt)
M-67-350-A	BARCAROLLE from "Tales of Hoffman" (Offenbach)
M-612-060-A	BARCAROLLE (Anton Rubenstein)
M-68-700-A	THE BAT - FLEDERMAUS PARAPHRASE (Strauss)
M-65-680-A	BEAUTIFUL BLUE DANUBE (Strauss)
M-66-240-A	LA BOHEME (Puccini)
	1. Rudolfo's Narrative 2. Mimi's Aria
	3. Musetta's Valse
M-614-730-A	CARMEN POTPOURRI (Bizet)
M-64-520-A	CAVALLERIA RUSTICANA INTERMEZZO & The TOREADOR SONG, from "Carmen"
M-64-230-A	CELESTE AIDA (Verdi)
M-611-400-A	CLAIR DE LUNE (Debussy)
M-6490-A	COPELLIA BALLET VALSE LENTE (Delibes)
M-617-460-A	CRADLE SONG Op. 49, No. 4 ("Brahms' Lullaby")
M-6430-A	DANCE OF THE HOURS
M-65-150-A	DANSE MACABRE (Saint-Saens)
M-615-880-A	DINNER MOSAIC No. 2
	1. Kiss Me Again 2. Gypsy Love Song
	3. Italian Street Song 4. I'm Falling In Love With Someone
	Played by Victor Arden
M-616-120-A	DINNER MOSAIC No. 3
	1. One Alone 2. Sympathy 3. Alice Blue Gown 4. My Hero
	Played by Victor Arden
M-616-800-A	DINNER MOSAIC No. 7
	1. Can't Help Lovin' That Man
	2. Lovely Lady 3. Ma Belle 4. Ol' Man River
	Played by Max Kortlander
M-617-100-A	DINNER MOSAIC No. 8
	1. Concert Waltz 2. Chanson 3. Echoes Of Spring 4. Valse Elise
	Played by Rudolph Friml
M-614-680	DIZZY FINGERS
M-61-200-A	DRINK TO ME ONLY WITH THINE EYES
M-610-650	HARD HEARTED HANNAH (The Vamp Of Savannah)
	Played by Pete Wendling
M-69-390-A	VICTOR HERBERT FAVORITES
	1. Kiss Me Again 2. Gypsy Love Song
	3. Love Is The Best Of All
M-62-610-A	HUNGARIAN RHAPSODY No. 2 (Liszt)
M-65-540-A	ICH LIEBE DICH (I Love You) (Grieg)
M-615-940-A	INTERMEZZO No. 2 (from "Jewels Of The Madonna") (Wolf Ferrari)
M-6530-A	ITALIAN SONG MEDLEY
	1. Maria Mari 2. O Sole Mio 3. Ciri-biribin 4. Funiculi, Funicula
M-65-560-A	THE JOLLY BLACKSMITH
M-66-340	KITTEN ON THE KEYS
M-68-990-A	LIEBESFREUD (Kreisler)
M-64-820-A	MAGIC FIRE SCENE (Wagner)
	(from "Die Walkure")
M-63-850-A	MAGNOLIA BLOSSOMS (Medley)
	1. Swanee River 2. Old Black Joe
	3. Turkey In The Straw 4. Marching Through Georgia 5. Sing Me A Song Of The South
M-616-610	THE MAN I LOVE (Gershwin)
M-65-620-A	MARCHE SLAVE (Tchaikowsky)
M-64-410-A	MARTHA (Selections) (Flotow)
M-65-320-A	MELODY in F (Rubenstein)
M-64-320-A	MISERERE from "Il Trovatore" (Verdi)
M-67-120-A	MOONLIGHT SONATA Op. 27, No. 2 (Beethoven)
M-65-920-A	NARCISSUS (Nevin)
M-65-910-A	NOCTURNE in E from "Midsummer Night's Dream" (Mendelssohn)
M-61-460-A	NOLA (Felix Arndt)
M-64-210-A	NORMA - Overture
M-65-960-A	O SOLE MIO (Di Capua)
M-613-690-A	PILGRIM'S CHORUS (Wagner)
	from "Tannhauser"
M-64-710-A	POET AND PEASANT - Overture (Von Suppe)
M-614-840-A	POLONAISE in C-Sharp Minor Op. 26, No. 1 (Chopin)
	Played by Leopold Godowsky
M-62-110-A	POLONAISE MILITAIRE in A-Major Op. 40, No. 1 (Chopin)
M-610-600-A	POPULAR SONGS OF OTHER DAYS
	Just One Girl; Sidewalks Of NY; Sweet Rosie O'Grady; Annie Rooney; Good Old Summertime; Daisy Daisy; Two Little Girls In Blue; After The Ball.
M-615-110-A	PRELUDE in C-Sharp Minor, Op. 3 (Rachmaninoff)
	Played by Leopold Godowsky
M-615-820-A	RHAPSODY IN BLUE (Part One) (Gershwin)
M-615-830-A	RHAPSODY IN BLUE (Part Two) (Gershwin)
M-63-510-A	RONDO CAPRICCIOSO (Mendelssohn)
M-68-020-A	RUSTLE OF SPRING (Sinding)
M-614-340-B	SANTA CLAUS TIME (A descriptive Christmas Roll with a Christmas story and Yuletide songs with words.)
M-68-210-A	SONGS MY MOTHER TAUGHT ME (Dvorak)
M-66-300-A	SOUSA MARCH MEDLEY
M-65-110-A	SOUVENIR (Drda)
M-616-870-A	STEPPIN' ON THE IVORIES
M-62-300-A	STUDY ON THE MINUTE WALTZ
M-615-270-A	TEASING THE KLASSICS
M-613-260-A	TO SPRING & THE BUTTERFLY (Grieg)
M-61-750-A	VALSE in C-Sharp Minor, Op. 64, No. 2 (Chopin)
M-64-510-A	WILLIAM TELL OVERTURE (Rossini)

Ampico

NOTICE: If you do not have an Ampico Reproducing Piano, but wish to play Ampico rolls, please see explanation below.

AMP-1002-A	MODEL "A" TEST ROLL (See Catalog for AMPICO Service Manual)
AMP-1041-A	AIN'T MISBEHAVIN' Played by Victor Arden
AMP-1038-A	BROTHER CAN YOU SPARE A DIME Played by Adam Carroll
AMP-1019-A	CARIOCA Played by Ohman & Arden
AMP-1013-C	CARMEN POTPOURRI No. 1 Played by Howard Brockway
AMP-1023-A	CHANSON TRISTE, Op. 42, No. 2 (Tchaikowsky) Played by Howard Brockway
AMP-1004-A	CHARLESTON RAG Played by the composer, Euble Blake
AMP-1008-A	CLAIR DE LUNE (Debussy) Played by Olga Samaroff
AMP-1012-A	THE CONTINENTAL Played by Arden & Carroll
AMP-1040-C	DANSE MACABRE (Saint-Saens--Henrlon) Played by Theodore Henrlon
AMP-1022-C	DINNER MUSIC No. 14
	1. Say It With Music 2. Tea For Two 3. Look For The Silver Lining 4. Night And Day 5. Rose Marie 6. They Didn't Believe Me
	Played by Adam Carroll
AMP-1016-A	ETUDE in C-Minor, Op. 10, No. 12 ("Revolutionary") (Chopin)
AMP-1011-A	ETUDE in E-Major, Op. 10, No. 3 (Chopin)
AMP-1033-A	ETUDE in E-Minor, Op. 10, No. 3 (Chopin)
AMP-1034-B	FIVE FOOT TWO, EYES OF BLUE Played by Ferde Grofe
AMP-1018-A	FANTASIE IMPROMPTU (Chopin) Played by Germaine Schnitzer
AMP-1027-A	FLIGHT OF THE BUMBLE BEE (Rimsky-Korsakov) Played by Rachmaninoff
AMP-1021-C	HAPPY DAYS ARE HERE AGAIN Played by Victor Arden
AMP-1028-A	HEAT WAVE, EASTER PARADE, & NOT FOR ALL THE RICE IN CHINA Played by Adam Carroll
AMP-1010-B	HUNGARIAN DANCE No. 5 (Brahms) Played by Marguerite Volavy
AMP-1025-A	HUNGARIAN RHAPSODY No. 2 (Liszt) Played by Alfred Cortot
AMP-1029-B	I ONLY HAVE EYES FOR YOU Played by Harry Shipman
AMP-1015-A	LIEBESTRAUM No. 3, "O Love". (Dream of Love) Nocturne (Liszt) Played by Leo Ornstein
AMP-1003-C	MINUTE WALTZ in D Flat, Op. 64, No. 1 (Chopin) Played by Eugen d'Albert
AMP-1039-B	NO NO NANETTE (Medley) Played by the composer, Vincent Youmans
AMP-1031-B	POLONAISE in A-Flat, Op. 53 (Chopin) Played by Leopold Godowsky
AMP-1026-C	POMP AND CIRCUMSTANCE (Elgar) Played by Kmita & Lambert
AMP-1017-A	SELECTIONS FROM "PAL JOEY" Played by Robert Farquhar
AMP-1007-A	STARDUST (Carmichael) Played by Emse Dawson
AMP-1030-A	SWANEE (Gershwin) Played by Clair & Pollock
AMP-1032-A	THESE FOOLISH THINGS REMIND ME OF YOU Played by Robert Farquhar
AMP-1024-A	TURKISH MARCH (Mozart) (Rondo in Turkish Style) Played by Lewis Richards
AMP-1001	TWO CIGARETTES IN THE DARK Played by Victor Arden
	YAAKA HULA, HICKEY DULA Played by the composer, Pete Wendling

MUSIC FOR CHRISTMAS

AMP-1037-A	HARK, THE HERALD ANGELS SING (Mendelssohn & Wesley) Played by Joseph Joiner
AMP-1036-A	OH, COME ALL YE FAITHFUL Played by Joseph Joiner
AMP-1035-A	SILENT NIGHT, HOLY NIGHT Played by Howard Brockway
AMP-1014-C	TOYLAND Played by Adam Carroll

Duo-Art

NOTICE: These rolls are not for use on modern Duo-Art Players! Please see explanation below.

DA-1002-C	TEST ROLL No. 3 (See Catalog for DUO-ART Service Manual.)
DA-1041-A	AIN'T MISBEHAVIN' Played by Lillian Jay
DA-1015-A	BODY AND SOUL Played by Robert Armbruster
DA-1038-A	BROTHER CAN YOU SPARE A DIME Played by Adam Carroll
DA-1019-A	CARIOCA Played by Ohman & Arden
DA-1023-C	CARMEN (Selections) (Bizet) Played by Erno Rapee
DA-1008-A	CLAIR DE LUNE (Debussy) Played by George Copeland
DA-1012-A	THE CONTINENTAL Played by Arden & Carroll
DA-1040-C	DANSE MACABRE (Saint-Saens--Liszt) Played by Vladimir Horowitz
DA-1022-C	DINNER MUSIC No. 14
	1. Say It With Music 2. Tea For Two 3. Look For The Silver Lining 4. Night And Day 5. Rose Marie 6. They Didn't Believe Me
	Played by Adam Carroll
DA-1017-A	ETUDE in C Minor, Op. 25, No. 12 (Chopin) Played by Vladimir Horowitz
DA-1016-A	ETUDE in E-Flat, Op. 10, No. 6 (Chopin) Played by Vladimir Horowitz
DA-1011-A	ETUDE in E-Major, Op. 10, No. 3 (Chopin) Played by Alfred Cortot
DA-1034-B	FANTASIE IMPROMPTU (Chopin) Played by Harold Bauer
DA-1033-A	FIVE FOOT TWO EYES OF BLUE Played by Phil Ohman
DA-1027-A	HAPPY DAYS ARE HERE AGAIN Played by Ralph Addison
DA-1021-B	HEAT WAVE, EASTER PARADE, & NOT FOR ALL THE RICE IN CHINA - Played by Adam Carroll
DA-1028-A	HUNGARIAN DANCE No. 5 (Brahms) Played by Harold Bauer
DA-1010-B	HUNGARIAN RHAPSODY No. 2 (Liszt) Played by Paderewsky
DA-1025-A	I ONLY HAVE EYES FOR YOU Played by Harry Shipman
DA-1009-A	(Keep Your) SUNNY SIDE UP Played by Pauline Alpert
DA-1029-C	LIEBESTRAUM No. 3, "O Love" (Dream Of Love) Nocturne (Liszt) Played by Rudolph Ganz
DA-1039-A	POLONAISE in A-Flat, Op. 53 (Chopin) Played by Josef Hofmann
DA-1031-B	POMP AND CIRCUMSTANCE (Elgar) Played by Edna Bentz
DA-1005-B	RHAPSODY IN BLUE Part 1 Played by the composer, George Gershwin
DA-1006-B	RHAPSODY IN BLUE Part 2 Played by the composer, George Gershwin
DA-1018-A	RITUAL DANCE OF FIRE (Falla-Rubenstein) Played by Artur Schnabel
DA-1007-A	SWANEE Played by the composer, George Gershwin
DA-1020-A	THAT OLD GANG OF MINE Played by Hess & Leith
DA-1030-A	THESE FOOLISH THINGS REMIND ME OF YOU Played by Robert Farquhar
DA-1032-A	TURKISH MARCH (from the Sonata in A) (Mozart) Played by Lewis Richards
DA-1024-A	TWO CIGARETTES IN THE DARK Played by Victor Arden
DA-1003-A	VALSE in D-Flat (Minute Waltz) (Chopin) Played by Ignace Friedman

MUSIC FOR CHRISTMAS

DA-1037-A	HARK, THE HERALD ANGELS SING (Mendelssohn & Wesley) Played by Erno Rapee
DA-1013-B	LAND OF THE CHRISTMAS STAR Played by Henri Bergman
DA-1036-A	OH, COME ALL YE FAITHFUL Played by Robert Armbruster
DA-1035-A	SILENT NIGHT, HOLY NIGHT Played by Henri Bergman

WHAT IS A REPRODUCING PIANO? AN EXPLANATION.

Several very sophisticated mechanical pianos were marketed in the Twenties and Thirties. They were called "reproducing pianos" because they could reproduce a live performance with amazing fidelity. The leading brands of reproducing pianos in the U.S. were the Ampico, the Welte, and the Duo-Art (not to be confused with the new Duo/Art manufactured by Aeolian Pianos, after 1950). All three brands play Q-R-S Rolls in addition to their own specially-coded rolls.

These rolls can also be played on any brand of player by covering with tape the holes on the tracker bar in the area of the expression holes on the roll. WARNING: After playing, these rolls will rewind automatically only on the corresponding brand of reproducing piano. They may rewind prematurely on other players unless the tracker bar holes are taped over.

FIFTY YEARS OF COUNTRY/WESTERN FAVORITES!



- 9239 Ace In The Hole
- 10-580 After The Lovin'
- 10-763 Always On My Mind
- 10-192 Am I That Easy To Forget
- 10-720 Angel Of The Morning
- 10-523 Annie's Song (John Denver)
- CEL-189-A Annie's Song
Played by Ferrante & Teicher
- 10-538 (Hey, Won't You Play) Another
Somebody Done Somebody
Wrong Song
- 10-774 Any Day Now (Ronnie Milsap)
- 8803 Anytime
- 3985 Are You Lonesome Tonight
- 3807 Arkansas Traveler
- 8519 Baby, It's Cold Outside
- 10-566 Back Home Again
- 7317 Back In The Saddle
- 9694 Battle Of New Orleans
- 10-522 Behind Closed Doors
- XP-214-B The Best Little Whorehouse In Texas
- 4645 Big Rock Candy Mountains
- 10-698 Blue Bayou
- 10-758 Bobbie Sue
- 7876 Born To Lose
- 10-780 Break It To Me Gently
- 10-226 By The Time I Get To Phoenix
- 8603 Chattanooga Shoe Shine Boy
- 8765 Cold Cold Heart
- 8154 Cool Water
- 10-674 Coward Of The County
- XP-210-B MAC DAVIS MEDLEY
Baby Don't Get Hooked On Me
I Believe In Music
It's Hard To Be Humble
- 9138 Davy Crockett
- 7591 Deep In The Heart Of Texas
- XP-189-C JOHN DENVER HITS
Back Home Again
Take Me Home, Country Roads
Thank God I'm A Country Boy
- 8770 Down Yonder
- 10-497 Duelling Banjos
- 9833 Does Your Chewing Gum Lose Its Flavor
- 10-607 Don't It Make My Brown Eyes Blue
- CEL-108-A Down At Papa Joe's
Played by Jo Ann Castle
- 9938 Down At Papa Joe's (Play-Along Roll)
- 10-728 Elvira
- 10-402 Everything Is Beautiful
- 10-442 For The Good Times
- 10-641 The Gambler
- 10-355 Games People Play
- 10-210 Gentle On My Mind
- 8581 Georgia On My Mind
- 10-285 Great Balls Of Fire
- 7174 Great Speckled Bird
- 10-354 Green, Green Grass Of Home
- 10-256 Harper Valley P.T.A.
- 8199 Have I Told You Lately That
I Love You
- 10-469 Help Me Make It
Through The Night
- 10-749 Here You Come Again
- 8873 High Noon (Do Not Forsake Me)
- 10-218 Honey (I Miss You)
- 9872 I Can't Stop Loving You
- 10-725 I Don't Need You (Kenny Rogers)
- Q-226 I Like Mountain Music
- 10-713 I Love A Rainy Night
- 8661 I Love You Because
- 10-751 I Was Country When Country
Wasn't Cool
- 10-384 If I Were A Carpenter
- 10-798 Islands In The Stream
- 8888 Jambalaya (On The Bayou)
- 8554 Jealous Heart
- 8936 Just A Closer Walk With Thee
- 10-075 King Of The Road
- 10-429 Knock Three Times
- 10-706 Lady (Kenny Rogers)
- 9777 Last Date (Floyd Cramer)
- 10-300 Let It Be Me
- 9856 A Little Bitty Tear
- 10-209 Little Green Apples
- 10-700 Lookin' For Love

- 10-756 Love In The First Degree
- 10-598 Lucille
- 10-076 Make The World Go Away
- 10-438 Me And Bobbie McGee
- 6329 Mexicali Rose (waltz)
- 8713 Mockin' Bird Hill
- 10-711 Nine To Five (Dolly Parton)
- 10-784 Nobody
- 7572 Old Shep
- 10-052 One Has My Name
(The Other Has My Heart)
- 9921 Painted, Tainted Rose
- 10-739 Paloma Blanca

- 9743 Paper Roses
- 8778 Peace In The Valley
- XP-179-B ELVIS PRESLEY, Vol. 1
Hound Dog
Love Me Tender
Jailhouse Rock
- XP-208-B ELVIS PRESLEY, Vol. 2
"Rockabilly Hits"
Heartbreak Hotel
G. I. Blues
Blue Suede Shoes
- XP-209-B ELVIS PRESLEY, Vol. 3
It's Now Or Never
Cryin' In The Chapel
Are You Lonesome Tonight
- XP-212-B RAY PRICE Country Favorites
For The Good Times
Release Me
Heartaches By The Number
- 10-734 Queen Of Hearts (Juice Newton)
- 7085 Ragtime Cowboy Joe
- 9881 Ramblin' Rose
- 7066 El Rancho Grande
- 10-158 Release Me
- 10-545 Rhinestone Cowboy
- 8757 Rhumba Boogie (Hank Snow)
- 8506 Riders In The Sky
- XP-188-C KENNY ROGERS HITS
The Gambler
She Believes In Me
You Decorated My Life

SACRED MUSIC Songs of Faith & Inspiration

- 121 Abide With Me
- 10-481 Amazing Grace
- 1391 Ave Maria (Bach-Gounod)
- 69-690 Ave Maria (Schubert)
- 654 Beautiful Isle Of Somewhere
- 9194 The Bible Tells Me So
- 3648 Blessed Assurance
- 8961 Bless This House
- 1515 Bringin' In The Sheaves
- 963 Church In The Wildwood
- 10-480 Day By Day (Godspell)
- 3772 DIVINITY REFLECTIONS No. 1
Beautiful Isle Of Somewhere
Lead Kindly Light
Nearer My God To Thee
- XP-230-C GOSPEL FAVORITES
Put Your Hand In The Hand
He's Got The Whole World In
His Hands
On The Jericho Road
- 7174 Great Speckled Bird
- 9215 He
- 9575 He's Got The Whole World In His Hands
- 9707 How Great Thou Art
- 8946 I Believe
- 1510 I Love To Tell The Story
- 1543 In The Garden
- 8686 It Is No Secret
- 1546 Jesus Loves Me
- 8936 Just A Closer Walk With Thee
- 1591 Just As I Am
- 2299 Life's Railway To Heaven
- 6913 The Lord's Prayer
- 10-782 Morning Has Broken
- 120 Nearer My God To Thee
- 1552 Old Rugged Cross
- 2300 Old Time Religion
- 10-836 One Day At A Time
- 1505 Onward Christian Soldiers
- 10-439 Put Your Hand In The Hand
- 962 Rock Of Ages
- 1545 Shall We Gather At The River
- 1500 Since Jesus Came Into My Heart
- 959 Softly And Tenderly
- 10-437 Superstar
- 1524 Sweet By And By
- 1594 Sweet Hour Of Prayer
- 1256 Swing Low, Sweet Chariot
- 9614 Take My Hand, Precious Lord
- 241 There Is Power In The Blood
- 8778 There'll Be Peace In The Valley
- 10-778 Wedding Song (There Is Love)
- 965 What A Friend We Have In Jesus
- 2056 When The Roll Is Called Up Yonder
- 3521 When They Ring The Golden Bells
- 961 Whispering Hope
- 2839 Will The Circle Be Unbroken
- 8880 You'll Never Walk Alone

- 10-428 Rose Garden
- 7410 San Antonio Rose, New
- 10-658 She Believes In Me
- 10-748 Sixteen Tons
- 8786 Slowpoke
- 10-410 Snowbird
- 7096 South Of The Border
- 10-588 Southern Nights
- 8677 Square Dance Medley
Old Folks At Home
Listen To The Mocking Bird
Buffalo Gals
Turkey In The Straw
- 10-272 Stand By Your Man
- Q-244 Stars Fell On Alabama
- 10-740 The Sweetest Thing (I've Ever Known)
- 10-453 Take Me Home, Country Roads
- 8436 Tennessee Waltz
- 9855 Tennessee Waltz (m)
- 10-535 Thank God I'm A Country Boy
- 10-679 This Land Is Your Land
- 9075 This Ole House
- 10-759 Through The Years
- 8912 Till I Waltz Again With You
- 10-808 To All The Girls I've Loved Before
- 7181 Tumbling Tumbleweeds
- 1105 Turkey In The Straw
- 2722 Virginia Reel (with calls)
- 7158 Wabash Cannonball
- 7638 Walking The Floor Over You
- XP-213-B WAYLON & WILLIE
Mamas, Don't Let Your Babies
Grow Up To Be Cowboys
On The Road Again
Good Ol' Boys (Dukes of Hazzard)
- 9309 The Wayward Wind
- 9987 We'll Sing In The Sunshine
- XP-211-B HANK WILLIAMS Country Favorites
Cold Cold Heart
Your Cheatin' Heart
Hey, Good Lookin'
- 9882 Wolverton Mountain
- 8777 The World Is Waiting For The Sunrise
- 7125 The Yellow Rose Of Texas
- CEL-106-A The Yellow Rose Of Texas
Played by Jo Ann Castle
- 10-347 Yesterday When I Was Young
- 7258 You Are My Sunshine
- 10-753 You're The Reason God Made Oklahoma
- 10-677 You Decorated My Life
- 10-603 You Light Up My Life
- 10-635 You Needed Me
- 8938 Your Cheatin' Heart

LET THESE FAMOUS PIANISTS



Ferrante & Teicher



Liberace



Eubie Blake



Roger Williams

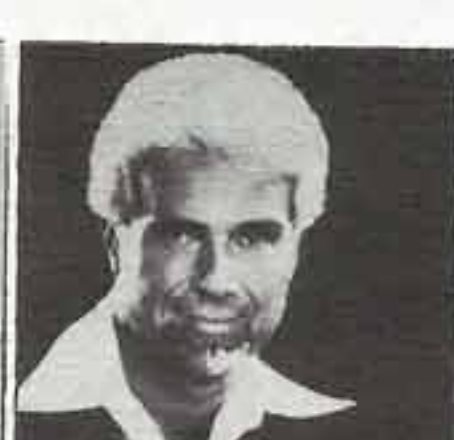

Peter Nero



George Shearing



William Bolcom



Peter Duchin



Jo Ann Castle



Charles Strouse



Marian McPartland



Max Morath

PERFORM FOR YOU!

Choose Q-R-S Celebrity Series Rolls if you want hand-played, live-recorded performances by world-famous pianists. It's like having these great stars perform just for you!

● JOANN CASTLE

- CEL-101-A The Sheik of Araby
- CEL-102-A Chopsticks (Instrumental)
- CEL-103-A Rudolph, The Red Nosed Reindeer
- CEL-104-A Santa Claus Is Coming To Town
- CEL-105-A Music! Music! (Put Another Nickel In)
- CEL-106-A Yellow Rose Of Texas
- CEL-107-A Skaters Boogie (Boogie on Skaters Waltz)
- CEL-108-A Down At Papa Joe's
- CEL-109-A Hello, Dolly!
- CEL-110-A The Old Piano Roll Blues

● LIBERACE

- CEL-111-A Prelude and Theme from "The Godfather"
- CEL-112-A Beer Barrel Polka
- CEL-113-A It's Impossible
- CEL-114-A White Christmas Medley
- CEL-115-A Love Story Medley
- CEL-116-A Alley Cat
- CEL-117-A Tea For Two
- CEL-118-A Somewhere My Love
- CEL-119-A Twelfth Street Rag
- CEL-120-A Impossible Dream
- CEL-121-B GERSHWIN MEDLEY:
Rhapsody In Blue (excerpt)
Someone To Watch Over Me
Swanee
The Man I Love
Fascinating Rhythm
I Got Rhythm
- CEL-122-A OLD FASHIONED WALTZ MEDLEY
Three O'Clock In The Morning
After The Ball
When Your Hair Has Turned To Silver
Let Me Call You Sweetheart
- CEL-140-A THREE LITTLE FISHES MEDLEY
- CEL-141-B BURT BACHARACH MEDLEY:
Close To You
Alfie
Raindrops Keep Fallin' On My Head
(See also "Jazz Personalities Series")

● EUBIE BLAKE

- CEL-123-A Rhapsody In Ragtime
- CEL-124-A Troublesome Ivories
- CEL-125-A Merry Widow Rag
- CEL-126-A Memories Of You
- CEL-127-A I'm Just Wild About Harry

All selections composed and played by Eubie Blake. See also *The Best Of The 20's*, and *Broadway Medleys*.

● ROGER WILLIAMS

- CEL-128-A Killing Me Softly With His Song
- CEL-129-A Tie A Yellow Ribbon 'Round The Ole Oak Tree
- CEL-130-A Autumn Leaves
- CEL-131-A On A Clear Day
- CEL-132-A Spanish Eyes
- CEL-133-A Born Free

(See also "Jazz Personalities Series")

● MAX MORATH

- CEL-134-A Easy Winners
- CEL-135-A Joplin's New Rag
- CEL-138-A The Entertainer
- CEL-139-A Cottontail Rag

● GEORGE SHEARING

- CEL-142-A I'm In The Mood For Love, and, Should I (medley)
- CEL-143-A The Breeze And I
- CEL-144-A Somewhere Over The Rainbow
- CEL-145-A I'll Remember April
(Courtesy of M.P.S Records)

● WILLIAM BOLCOM

- CEL-150-A Country Club (Joplin)
- CEL-152-A Paragon Rag (Joplin)
- CEL-153-A The Cascades (Joplin)
- CEL-156-A Pineapple Rag (Joplin)

● PETER DUCHIN

- CEL-157-A More (from "Mondo Cane")
- CEL-158-A Christmas Song (Chestnuts Roasting)
- CEL-160-A All The Things You Are
- CEL-161-A Bill Bailey Won't You Please Come Home
- CEL-162-B EDDY DUCHIN MEDLEY:
Embraceable You
Someone To Watch Over Me
The Man I Love
You're My Everything

● PETER NERO

- CEL-163-A Mountain Greenery
- CEL-164-A Scratch My Back (Nero)
- CEL-166-B I've Got Rhythm Medley
- CEL-167-A The Summer Knows (from "Summer Of '42")
- CEL-168-A We've Only Just Begun
- CEL-169-A Sunday In New York

● CHARLES STROUSE

- CEL-170-A Put On A Happy Face
"Bye Bye Birdie"
- CEL-171-A Once Upon A Time
"Americana"
- CEL-173-A I've Got A Lot Of Living To Do
"Bye Bye Birdie"
- CEL-174-A Kids "Bye Bye Birdie"
- CEL-175-A Applause "Applause"
- CEL-176-A Those Were The Days "All In The Family"
- CEL-191-A Tomorrow "Annie"
All selections composed and played by Charles Strouse. See also "ANNIE".

● MARIAN McPARTLAND

- CEL-177-A Evergreen
- CEL-178-A If (A Picture Paints A Thousand Words)
- CEL-180-B BEATLES MEDLEY:
Michelle
Norwegian Wood
Eleanor Rigby
- CEL-181-A Send In The Clowns
- CEL-182-A Just The Way You Are
- CEL-183-A Chick Corea's Crystal Silence
- CEL-184-B DUKE ELLINGTON MEDLEY:
Don't Get Around Much Anymore
Mood Indigo
Satin Doll
It Don't Mean A Thing If It Ain't Got That Swing

● FERRANTE & TEICHER

- CEL-185-A Greensleeves (What Child Is This)
- CEL-186-A Exodus
- CEL-187-A Feelings
- CEL-188-A The Apartment (Theme)
- CEL-189-A Annie's Song
- CEL-190-A Amtrak Boogie Woogie
- CEL-192-A Chariots Of Fire
- CEL-193-C SIMON & GARFUNKEL MEDLEY:
Sound Of Silence
Fifty-Ninth Street Bridge Song (Feelin' Groovy)
Scarborough Fair
Mrs. Robinson
- CEL-194-A My Way
- CEL-195-A St. Louis Blues
- CEL-196-A Tiger Rag
- CEL-197-B Clair De Lune

● EARL "FATHA" HINES

- CEL-146-B Blues In Thirds
- CEL-147-C (Boogie Woogie on) St. Louis Blues

HAND-PLAYED ROLLS BY THE WORLD'S GREATEST PIANISTS

Q·R·S CELEBRITY SERIES

YOU'VE GOT FRONT ROW SEATS TO THESE

LONG-PLAYING BROADWAY MUSICALS!

XP-232-B AMADEUS

1. Piano Concerto in D minor, K. 466, 2nd movement; 2. Concerto for Two Pianos, K. 365, 3rd movement; 3. Piano Concerto in E flat, K. 482, 3rd movement

XP-183-B AIN'T MISBEHAVIN'

(Played by composer 'Fats' Waller and J. Lawrence Cook)

1. Ain't Misbehavin'; 2. I Can't Give You Anything But Love; 3. Tain't Nobody's Bizness If I Do; 4. Squeeze Me; 5. Honeysuckle Rose.

XP-180-B ANNIE (Part 1)

(An exclusive live performance by the show's composer, Charles Strouse) 1. Maybe; 2. It's The Hard Knock Life; 3. Tomorrow; 4. We'd Like To Thank You; 5. Little Girls; 6. I Think I'm Gonna Like It Here

XP-181-B ANNIE (Part 2)

1. NYC; 2. Easy Street; 3. You Won't Be An Orphan For Long; 4. You're Never Really Dressed Without A Smile; 5. Something Was Missing; 6. I Don't Need Anything But You; 7. Annie

XP-142-B ANNIE GET YOUR GUN (Part 1)

1. There's No Business Like Show Business; 2. My Defenses Are Down; 3. Anything You Can Do; 4. Girl That I Marry; 5. You Can't Get A Man With A Gun

XP-143-B ANNIE GET YOUR GUN (Part 2)

1. I Got The Sun In The Morning; 2. Moonshine Lullaby; 3. Who Do You Love, I Hope; 4. I Got Lost In His Arms; 5. Doin' What Comes Nat'rally; 6. They Say It's Wonderful

XP-214-B THE BEST LITTLE WHOREHOUSE IN TEXAS

(RECOMMENDED FOR ADULTS ONLY)

1. Twenty Fans; 2. Lil' Ol' Bitty Pissant Country Place; 3. Texas Has A Whorehouse In It; 4. The Aggie Song; 5. The Sidestep; 6. Hard Candy Christmas

XP-140-B BRIGADOON

1. I'll Go Home With Bonnie Jean; 2. Down On MacConnachy Square; 3. Heather On The Hill; 4. Almost Like Being In Love; 5. Come To Me, Bend To Me; 6. Waitin' For My Dearie; 7. Jeannie's Packin' Up; 8. There But For You Go I; 9. Brigadoon

XP-164-B CABARET (Part 1)

1. Willkommen; 2. Don't Tell Mama; 3. Perfectly Marvelous; 4. Two Ladies; 5. It Couldn't Please Me More; 6. Tomorrow Belongs To Me; 7. Sitting Pretty

XP-165-B CABARET (Part 2)

1. If You Could See Her Through My Eyes; 2. Meeskite; 3. Why Should I Wake Up; 4. Married; 5. Cabaret; 6. Finale

XP-220-B LA CAGE AUX FOLLES

1. We Are What We Are; 2. With You On My Arm; 3. Song On The Sand; 4. I Am What I Am; 5. The Best Of Times; 6. La Cage Aux Folles

XP-136-B CAMELOT

1. Camelot; 2. If Ever I Would Leave You; 3. What Do The Simple Folk Do; 4. How To Handle A Woman; 5. Lusty Month Of May; 6. I Loved You Once In Silence

XP-123-B CAROUSEL

1. Carousel Waltz; 2. June Is Bustin' Out All Over; 3. If I Loved You; 4. A Real Nice Clambake; 5. Mister Snow; 6. What's The Use Of Wonderin'; 7. You'll Never Walk Alone

XP-191-B CHICAGO MEDLEY (Part 1)

1. And All That Jazz; 2. Funny Honey; 3. Cell Block Tango; 4. When You're Good To Mama; 5. All I Care About Is Love; 6. I Can't Do It Alone; 7. My Own Best Friend

XP-192-B CHICAGO MEDLEY (Part 2)

1. I Know A Girl; 2. Rosie; 3. Cellophane; 4. Cass; 5. Razzel Dazzel; 6. Both Reached For The Gun; 7. Nowadays; 8. Honey Rag

XP-177-B A CHORUS LINE (Part 1)

(RECOMMENDED FOR ADULTS ONLY)

1. I Hope I Get It; 2. I Can Do That; 3. At The Ballet; 4. Hello Twelve, Hello Thirteen, Hello Love; 5. Nothing

XP-178-B A CHORUS LINE (Part 2)

(RECOMMENDED FOR ADULTS ONLY)

1. The Music And The Mirror; 2. Dance; Ten; Looks; Three; 3. One; 4. What I Did For Love

XP-138-A GEO. M. COHAN MEDLEY (Pt. 1)

1. Yankee Doodle Boy; 2. Mary's A Grand Old Name; 3. Forty-Five Minutes From Broadway; 4. You're A Grand Old Flag

XP-139-A GEO. M. COHAN MEDLEY (Pt. 2)

1. Give My Regards To Broadway; 2. So Long Mary; 3. Harrigan; 4. Over There

XP-135-B THE FANTASTICKS

1. Overture; 2. Try To Remember; 3. Metaphor (Love, You Are Love); 4. It Depends On What You Pay; 5. Soon It's Gonna Rain; 6. Rape Ballet; 7. I Can See It.

XP-122-B FIDDLER ON THE ROOF

1. Fiddler On The Roof; 2. Matchmaker; 3. If I Were A Rich Man; 4. Sunrise, Sunset; 5. To Life

XP-141-B FINIAN'S RAINBOW

1. If This Isn't Love; 2. How Are Things In Glocca Morra; 3. Old Devil Moon; 4. When I'm Not Near The Girl I Love; 5. Something Sort Of Grandish; 6. Look To The Rainbow; 7. That Great Come And Get It Day

XP-199-B FORTY-SECOND STREET (Pt. 1)

1. Shadow Waltz; 2. Shuffle Off To Buffalo; 3. Young And Healthy; 4. Lullaby Of Broadway; 5. Forty-Second Street

XP-202-B FORTY-SECOND STREET (Pt. 2)

1. You're Getting To Be A Habit With Me; 2. About A Quarter To Nine; 3. Dames; 4. Go Into Your Dance; 5. We're In The Money

XP-144-B FUNNY GIRL

1. Overture; 2. Greatest Star; 3. People; 4. You Are Woman; 5. Sadie, Sadie, Married Lady; 6. Don't Rain On My Parade

XP-185-B GYPSY MEDLEY

1. Overture; 2. Let Me Entertain You; 3. Some People; 4. Small World; 5. Baby June & Her Newsboys; 6. Mr. Goldstone; 7. Little Lamb; 8. You'll Never Get Away From Me

XP-152-B HELLO DOLLY! (Part 1)

1. Hello, Dolly!; 2. I Put My Hand In; 3. It Takes A Woman; 4. Put On Your Sunday Clothes; 5. Ribbons Down My Back; 6. Motherhood March

XP-153-B HELLO DOLLY! (Part 2)

1. Dancing; 2. Before The Parade Passes By; 3. Elegance; 4. It Only Takes A Moment; 5. So Long Dearie; 6. Hello, Dolly!

XP-130-B THE KING AND I

1. March Of The Siamese Children; 2. Getting To Know You; 3. We Kiss In A Shadow; 4. Hello Young Lovers; 5. Shall We Dance; 6. I Have Dreamed; 7. I Whistle A Happy Tune; 8. Something Wonderful

XP-176-B MAN OF LaMANCHA

1. Introduction and Man of LaMancha; 2. It's All The Same; 3. Dulcinea; 4. I'm Only Thinking Of Him; 5. Little Bird; 6. Aldonza; 7. The Impossible Dream

XP-134-B MUSIC MAN

1. Seventy-Six Trombones; 2. Gary, Indiana; 3. Till There Was You; 4. Wells Fargo Wagon; 5. Goodnight My Someone; 6. Lida Rose (Note: Performances of The Music Man also require 'Columbia, Gem Of The Ocean' [3570] and 'Rustle Of Spring' [R-113-A])

XP-124-B MY FAIR LADY

1. On The Street Where You Live; 2. I Could Have Danced All Night; 3. Get Me To The Church On Time; 4. Wouldn't It Be Lovely; 5. I've Grown Accustomed To Her Face; 6. With A Little Bit Of Luck

XP-1003-B NO NO NANETTE

(Played by composer Vincent Youmans)

1. Tea For Two; 2. No No Nanette; 3. Where Has My Hubby Gone Blues; 4. The One You Love; 5. You Can Dance With Any Girl At All; 6. I Want To Be Happy

XP-121-B OKLAHOMA!

1. Oklahoma; 2. Oh, What A Beautiful Morning; 3. Surrey With The Fringe On Top; 4. Out Of My Dreams; 5. People Will Say We're In Love

XP-148-B OLIVER! (Part 1)

1. Consider Yourself; 2. As Long As He Needs Me; 3. Oliver; 4. Pick A Pocket Or Two; 5. Reviewing The Situation; 6. Food Glorious Food

XP-149-B OLIVER! (Part 2)

1. Who Will Buy; 2. Where Is Love; 3. It's A Fine Life; 4. Be Back Soon; 5. Oom-Pah-Pah; 6. I'd Do Anything

XP-151-B PAINT YOUR WAGON

1. I'm On My Way; 2. I Still See Elisa; 3. I Talk To The Trees; 4. What's Goin' On Here; 5. Hand Me Down That Can O' Beans; 6. Carino Mio; 7. Another Autumn; 8. They Call The Wind Maria

XP-205-B THE PIRATES OF PENZANCE

1. Pirate's Chorus; 2. Frederic's Song; 3. Mabel's Waltz Song; 4. The Policeman's Lot; 5. Song Of The Major General; 6. Finale

XP-125-B PORGY AND BESS

1. Summertime; 2. I Got Plenty Of Nothin'; 3. My Man's Gone Now; 4. Tain't Necessarily So; 5. Bess You Is My Woman

XP-126-B SHOW BOAT

1. Make Believe; 2. Why Do I Love You; 3. Bill; 4. Can't Help Lovin' Dat Man; 5. You Are Love; 6. Old Man River

XP-167-B Eubie Blake's SHUFFLE ALONG

(Played by Pete Wendling, April, 1922)

1. Love Will Find A Way; 2. Baltimore Buzz; 3. Bandana Days; 4. I'm Just Wild About Harry; 4. Gypsy Blues

XP-200-B SOPHISTICATED LADIES (Pt. 1)

1. I'm Beginning To See The Light; 2. Sophisticated Lady; 3. Don't Get Around Much Anymore; 4. Solitude

XP-206-B SOPHISTICATED LADIES (Pt. 2)

1. I Got It Bad And That Ain't Good; 2. Mood Indigo; 3. I Let A Song Go Out Of My Heart; 4. Do Nothing Till You Hear From Me

XP-129-B THE SOUND OF MUSIC

1. The Sound Of Music; 2. My Favorite Things; 3. Maria; 4. Do Re Mi; 5. I Am Sixteen Going On Seventeen; 6. Edelweiss; 7. Climb Every Mountain

XP-131-B SOUTH PACIFIC (Part 1)

1. There Is Nothing Like A Dame; 2. Dites Moi; 3. Bali Hai; 4. A Wonderful Guy

XP-132-B SOUTH PACIFIC (Part 2)

1. Happy Talk; 2. Some Enchanted Evening; 3. I'm Gonna Wash That Man Right Outta My Hair; 4. Honey Bun; 5. Younger Than Springtime

612-800-B THE STUDENT PRINCE

1. Serenade; 2. Drinking Song; 3. Deep In My Heart Dear; 4. Student March Song

XP-150-B SWEET CHARITY

1. Sweet Charity; 2. If My Friends Could See Me Now; 3. Big Spender; 4. I Love To Cry At Weddings; 5. There's Gotta Be Something Better Than This; 6. Where Am I Going

XP-133-B WEST SIDE STORY

1. Overture; 2. I Feel Pretty; 3. Tonight; 4. One Hand, One Heart; 5. Maria; 6. Somewhere; 7. Something's Coming

XP-217-B THE WIZARD OF OZ

1. Over The Rainbow; 2. Munchkin Land; 3. Ding-Dong! The Witch Is Dead; 4. Lullaby League & Lollipop Guild; 5. We're Off To See The Wizard; 6. If I Only Had A Brain; 7. The Merry Old Land Of Oz

MORE LONG-

XP-106-A ALL-TIME FOOTBALL FAVORITES

1. On Wisconsin; 2. Down The Field (Yale)

XP-234-A ANTIQUE AUTOMOBILE SONGS

1. See The USA In Your Chevrolet; 2. My Buick, My Love and I; 3. The Little Ford Rambled Right Along; 4. Ray And His Little Chevrolet; 5. Rolls Royce Papa, Your Tin Lizzy Mama Is Gonna Tow You In; 6. He'd Have To Get Under (Get Out & Get Under)

XP-155-B CARNIVAL OF THE ANIMALS

(Delightful verses by humorist Ogden Nash combined with the classic animal pieces by Saint-Saens!)

1. Introduction; 2. Royal March of the Lions; 3. Cocks and Hens; 4. Wild Jackass; 5. Turtles; 6. Elephants; 7. Kangaroos; 8. Aquarium; 9. Mules; 10. Cuckoo In The Woods

20-127-A ECHOES FROM THE METROPOLITAN OPERA HOUSE

1. The Prophet; 2. Alda; 3. Cavalleria Rusticana; 4. Boabdil; 5. Tannhauser; 6. Nibelungen; 7. Pagliacci; 8. William Tell

589 FAVORITE DANCE MEDLEY

1. Old Black Joe; 2. Comin' Thro' The Rye; 3. Rocked In The Cradle Of The Deep; 4. In The Gloaming; 5. When You And I Were Young, Maggie; 6. Love's Old Sweet Song

200-494-A FAVORITE ITALIAN SONGS

1. Maria Mari; 2. O Sole Mio; 3. Ciribiribin; 4. Funiculi, Funicula

7184 FAVORITE OLD TIME WALTZES

1. Sunshine of Paradise Alley; 2. She's More To Be Pittied Than Censured; 3. I Don't Want To Play In Your Yard; 4. Absence Makes The Heart Grow Fonder

7177 FAVORITE OLD TIMERS

1. Bill Bailey; 2. Good Morning, Carrie; 3. Just Because She Made Dem Goo Goo Eyes

★ REACH FOR THE STARS WITH Q-R-S SUPERSTAR MEDLEYS! ★

XP-219-B ANDREWS SISTERS MEDLEY

1. Don't Sit Under The Apple Tree; 2. In Apple Blossom Time; 3. Bei Bistu Schoen

CEL-141-B BURT BACHARACH MEDLEY

(Played by Liberace)
1. Close To You; 2. Alfie; 3. Raindrops Keep Fallin' On My Head

XP-231-C BEATLES HITS, VOL. 1

1. Yesterday; 2. Michelle; 3. Penny Lane

CEL-180-B BEATLES MEDLEY

(Played by Marian McPartland)
1. Michelle; 2. Norwegian Wood; 3. Eleanor Rigby

XP-190-C BEE GEE HITS

1. Jive Talkin'; 2. How Deep Is Your Love; 3. Night Fever

XP-101-B IRVING BERLIN HITS

1. Alexander's Ragtime Band; 2. A Pretty Girl Is Like A Melody; 3. Always; 4. Say It Isn't So; 5. Blue Skies

XP-207-B HOAGY CARMICHAEL HITS

1. Stardust; 2. Ole Buttermilk Sky; 3. Lazy Bones; 4. The Nearness Of You

XP-196-C THE CARPENTERS HITS, VOL. 1

1. Sing (Sing A Song); 2. Top Of The World; 3. Please Mr. Postman

XP-223-C NAT "KING" COLE MEDLEY

1. Nature Boy; 2. Mona Lisa; 3. Pretend

XP-182-B BING CROSBY MEDLEY

1. White Christmas; 2. Swingin' On A Star; 3. Where The Blue Of The Night; 4. Bells of St. Mary's

XP-210-B MAC DAVIS MEDLEY

1. Baby Don't Get Hooked on Me; 2. I Believe in Music; 3. It's Hard To Be Humble

XP-189-C JOHN DENVER HITS, VOL. 1

1. Back Home Again; 2. Take Me Home, Country Roads; 3. Thank God I'm A Country Boy

228-C TOMMY DORSEY HITS

1. I'm Getting Sentimental Over You; 2. Beale St. Blues; 3. Boogie Woogie (solo)

CEL-162-B EDDY DUCHIN MEDLEY

1. Embraceable You; 2. Someone To Watch Over Me; 3. The Man I Love; 4. You're My Everything

CEL-184-B DUKE ELLINGTON MEDLEY

(Played by Marian McPartland)
1. Don't Get Around-Much Anymore; 2. Mood Indigo; 3. Satin Doll; 4. It Don't Mean A Thing If It Ain't Got That Swing

XP-108-A GERSHWIN FESTIVAL

1. A Foggy Day; 2. But Not For Me

CEL-121-B GEORGE GERSHWIN MEDLEY

(Played by Liberace)
1. Rhapsody In Blue (excerpt); 2. Someone To Watch Over Me; 3. Swanee; 4. The Man I Love; 5. Fascinating Rhythm; 6. I Got Rhythm

XP-225-C BENNY GOODMAN HITS

1. Gotta Be This Or That; 2. Stompin' At The Savoy; 3. One O'Clock Jump

81-117-A VICTOR HERBERT FAVORITES

1. Kiss Me Again; 2. Gypsy Love Song; 3. Love Is The Best Of All

XP-222-A MICHAEL JACKSON HITS

1. Billie Jean; 2. Beat It

XP-218-B HARRY JAMES HITS

1. I've Heard That Song Before; 2. It's Been A Long, Long Time; 3. Ciribiribin

XP-194-C AL JOLSON HITS

1. Swanee; 2. My Mammy; 3. April Showers

9497 JOPLIN MEDLEY NO. 1

1. Fig Leaf Rag; 2. Sensation Rag

9857 JOPLIN MEDLEY NO. 2

1. The Entertainer ("The Sting"); 2. Joplin's New Rag

XP-215-B JOPLIN RAGS FROM "THE STING"

1. Pineapple Rag; 2. The Entertainer; 3. Solace

XP-216-B JOPLIN RAGS FROM "THE STING II"

1. Bethena; 2. The Chrysanthemum; 3. Heliotrope Bouquet

XP-187-C BARRY MANILOW HITS, VOL. 1

1. Tryin' To Get The Feeling Again; 2. I Write The Songs; 3. Can't Smile Without You

XP-193-C BARRY MANILOW HITS, VOL. 2

1. Ships; 2. Mandy; 3. Copacabana (At The Copa)

XP-221-B ETHEL MERMAN MEDLEY

1. There's No Business Like Show Business; 2. You're Just In Love; 3. I Got Rhythm

XP-195-C GLENN MILLER HITS, VOL. 1

1. Moonlight Serenade; 2. Tuxedo Junction; 3. Little Brown Jug; 4. String Of Pearls

XP-224-C GLENN MILLER HITS, VOL. 2

1. At Last; 2. Chattanooga Choo Choo; 3. I've Got A Gal In Kalamazoo

XP-227-C MILLS BROS. HITS

1. Lazy River; 2. Paper Doll; 3. Yellow Bird

XP-179-B ELVIS PRESLEY MEDLEY

1. Hound Dog; 2. Love Me Tender; 3. Jailhouse Rock

XP-208-B ELVIS PRESLEY, VOL. 2

1. Heartbreak Hotel; 2. G.I. Blues; 3. Blue Suede Shoes

XP-209-B ELVIS PRESLEY, VOL. 3

1. It's Now Or Never; 2. Cryin' In The Chapel; 3. Are You Lonesome Tonight?

XP-212-B RAY PRICE COUNTRY FAVORITES

1. For The Good Times; 2. Release Me; 3. Heartaches By The Number

XP-188-C KENNY ROGERS HITS, VOL. 1

1. The Gambler; 2. She Believes In Me; 3. You Decorated My Life

CEL-193-C SIMON & GARFUNKEL HITS

(Played by Ferrante & Teicher)
1. Sound of Silence; 2. 59th St. Bridge Song (Feelin' Groovy); 3. Scarborough Fair; 4. Mrs. Robinson

XP-226-C FRANK SINATRA HITS

1. My Way; 2. New York, New York; 3. Strangers In The Night

XP-137-A SHIRLEY TEMPLE HITS

1. On The Good Ship Lollipop; 2. Codfish Ball; 3. Polly Wolly Doodle

XP-213-B WAYLON & WILLIE

1. Mamas, Don't Let Your Babies Grow Up To Be Cowboys; 2. On The Road Again; 3. Good Ol' Boys (Dukes of Hazzard)

XP-211-B HANK WILLIAMS COUNTRY FAVORITES

1. Cold Cold Heart; 2. Your Cheatin' Heart; 3. Hey Good Lookin'

PLAYING FAVORITES – MORE MUSIC FOR YOUR MONEY

2034-A FIRESIDE SONGS

1. Silver Threads Among The Gold; 2. Love's Sweet Song; 3. Sweetest Story Ever Told; 4. Sweet Adeline; 5. My Old Kentucky Home; 6. Then You'll Remember Me

2955 GOOD OLD FAVORITES

1. The Bowery; 2. In My Merry Oldsmobile; 3. In The Shade Of The Old Apple Tree; 4. Tammany

XP-230-C GOSPEL FAVORITES

1. Put Your Hand In The Hand; 2. He's Got The Whole World In His Hands; 3. On The Jericho Road

8312 HAPPY BIRTHDAY MEDLEY

1. Happy Birthday To You; 2. For He's A Jolly Good Fellow; 3. Hail, Hail The Gang's All Here; 4. How Dry I Am; 5. Auld Lang Syne

8312-C HAPPY BIRTHDAY — DELUXE EDITION

(Instrumental; Punched on colorful gift wrap.)

1. Happy Birthday To You; 2. For He's A Jolly Good Fellow; 3. Hail, Hail The Gang's All Here; 4. How Dry I Am; 5. Auld Lang Syne

XP-120-A HELLO DOLLY/PUT ON A HAPPY FACE

168-B HOME MINSTREL SERIES NO. 1

(Complete with jokesheets for a Minstrel Show at home!)

1. Opening Chorus; 2. Darktown Is Out Tonight; 3. Just Break The News To Mother; 4. Lindy; 5. Carry Me Back To Old Virginny; 7. Is Everybody Happy

XP-169-B HOME MINSTREL SERIES NO. 2

(Complete with jokesheets for a Minstrel Show at home!)

1. Opening Chorus; 2. Lazy Moon; 3. Sweet Adeline; 4. Mirandy; 5. Massa's In The Cold, Cold Ground.

XP-112-A IT HAD TO BE YOU/

SWEET GEORGIA BROWN

CEL-166-B I'VE GOT RHYTHM

(Played by Peter Nero) (Concert Paraphrase)

XP-114-A I'LL BE SEEING YOU/

GETTING TO KNOW YOU

1906-A MAGNOLIA BLOSSOMS

1. Swanee River; 2. Old Black Joe; 3. Turkey In The Straw; 4. Marching Through Georgia; 5. Sing Me A Song Of The South

R-253 MARCH KING MEDLEY

1. Washington Post; 2. Semper Fidelis

9855-A MEMORY SONGS

1. Good Old Summertime; 2. Only One Girl; 3. Daisey, Daisey; 4. Up In A Balloon; 5. You Tell Me Your Dream; 6. My Sweetheart's The Man In The Moon; 7. Mr. Moon; 8. Good-bye My Coney Island Baby; 9. That's Where My Money Goes; 10. Bill Bailey; 11. Good Night, Ladies

XP-118-A MY GAL SAL/IN THE GOOD OLD SUMMERTIME

CEL-122-A OLD-FASHIONED WALTZ MEDLEY

(Played by Liberace)

1. Three O'clock In The Morning; 2. After The Bell; 3. When Your Hair Has Turned To Silver; 4. Let Me Call You Sweetheart

1370 OLD FASHIONED WALTZES

1. Daisey, Daisey (Bicycle Built For Two); 2. Two Little Girls In Blue; 3. After The Ball; 4. Just One Girl; 5. Sidewalks of New York; 6. Sweet Rosie O'Grady; 7. Annie Rooney

XP-115-A OLD PIANO ROLL BLUES/JUST BECAUSE

C-114-A PLANTATION SONGS

1. Swanee River; 2. My Old Kentucky Home; 3. Old Black Joe; 4. Massa's In De Cold Cold Ground

XP-229-C POLKA MEDLEY

1. Pennsylvania Polka; 2. Beer Barrel Polka; 3. Too Fat Polka

XP-107-B POPULAR SONGS OF OTHER DAYS

1. Just One Girl; 2. Sidewalks Of New York; 3. Sweet Rosie O'Grady; 4. Annie Rooney; 5. Good Old Summertime; 6. Daisey, Daisey (Bicycle Built For Two); 7. Ain't Dat A Shame; 8. Fountain In The Park (While Strolling Thru The Park); 9. Guess I'll Have To Telegraph My Baby

XP-233-B ROARING 20's PARTY MEDLEY

(RECOMMENDED FOR ADULTS ONLY)

1. Masculine Women, Feminine Men; 2. Any Ice Today, Lady; 3. How Could Red Riding Hood

C-119-A SEA SONGS (Instrumental)

1. Sailing; 2. Starboard Watch; 3. Life On The Ocean Wave; 4. Sailor's Hornpipe; 5. Tarpaulin Jacket; 6. Asleep In The Deep; 7. Anchored

XP-163-B SORCERER'S APPRENTICE

(From Walt Disney's Fantasia) Story Roll with Poetry

XP-203-A STARS ON 45

1. Venus; 2. Sugar, Sugar; 3. No Reply; 4. I'll Be Back; 5. Drive My Car; 6. Do You Want To Know A Secret; 7. We Can Work It Out; 8. I Should Have Known Better; 9. Nowhere Man; 10. You're Going To Lose That Girl

XP-111-A SIDEWALKS OF NEW YORK/ MAKIN' WHOOPEE

XP-117-A SOMEBODY ELSE IS TAKING MY PLACE/IF YOU KNEW SUSIE

XP-147-A THANKSGIVING MEDLEY

1. Pilgrim's Chorus; 2. Bless This House; 3. Over The River And Through The Woods; 4. Prayer Of Thanksgiving

The Only Authentic JOPLIN RAGS



Scott Joplin (1863-1917) was truly the King of Ragtime. Shortly before his death, he made several hand-played piano rolls for the Connorized Music Co., which was acquired by Q-R-S back in the 1920's. Here, along with other Joplin rags played by various artists, are those rare recordings---living documents of a bygone era.

Reissues played by Scott Joplin:

- 9725 MAPLE LEAF RAG
- Q-196 MAGNETIC RAG
- Q-203 OLE MISS RAG
- Q-197 SOMETHIN' DOIN'
- Q-198 WEEPING WILLOW

More Great Joplin Rags:

- CEL-153-A THE CASCADES
- CEL-150-A COUNTRY CLUB RAG
- CEL-134-A EASY WINNERS
- CEL-138-A THE ENTERTAINER ("The Sting")
- 10-518 THE ENTERTAINER
Played by Oakes & Williams
- 9497 JOPLIN MEDLEY No. 1
Fig Leaf Rag & Sensation Rag
- 9857 JOPLIN MEDLEY No. 2
Entertainer & Joplin's New Rag
- XP-215-B JOPLIN RAGS FROM 'THE STING'
Pineapple Rag, The Entertainer, Solace
- XP-216-B JOPLIN RAGS FROM 'THE STING II'
Heliotrope Bouquet, Bethena, The Chrysanthemum
- CEL-135-A JOPLIN'S NEW RAG
- CEL-152-A PARAGON RAG
- CEL-156-A PINEAPPLE RAG
- 10-524 PINEAPPLE RAG
Played by Oakes & Williams
- 10-519 SOLACE
Played by Oakes & Williams

J. Lawrence Cook's JAZZ PERSONALITIES SERIES

J. Lawrence Cook (1899-1977) was the undisputed master of piano roll recording for over 40 years. Between 1921 and 1961, he recorded thousands of rolls for Q-R-S which remain unsurpassed for their balance and imagination.

This series of rolls, in which he ingeniously duplicated the styles of many great artists, contains some of his finest work. Listen and you'll know what we mean when we say, "Q-R-S Player Rolls are Better!"

- 9518 AUTUMN IN NEW YORK
As played by Maurice Whitney
- 9624 BARNEY GOOGLE
As played by Tiny Little, Jr.
- 9342 CANADIAN SUNSET
As played by Eddie Heywood
- 9299 CARLE BOOGIE
As played by Frankie Carle
- 9339 CHINA BOY
As played by Teddy Wilson
- 9317 EXACTLY LIKE YOU
As played by Frankie Carle
- 4973 GET HAPPY
As played by Art Tatum
- 9323 I'LL BE SEEING YOU
As played by Liberace
- 9595 KING PORTER STOMP
As played by Jelly Roll Morton
- 8706 LITTLE ROCK GETAWAY
As played by Bob Zurke
- 9625 NEAR YOU
As played by Roger Williams
- 9401 PRISONER OF LOVE
As played by Liberace
- 9668 ROW, ROW, ROW
As played by Johnny Maddox
- 9315 SLAUGHTER ON TENTH AVENUE
As played by Liberace
- 9530 STOMPIN' AT THE SAVOY
As played by Art Tatum
- 7960 SWEET LORRAINE
As played by Art Tatum
- 9516 TENDERLY
As played by Liberace
- 9461 THANKS FOR THE MEMORY
As played by Jack Fina
- 9443 THE VERY THOUGHT OF YOU
As played by Carmen Cavallaro
- 9514 WHEN MY SUGAR WALKS DOWN THE STREET
As played by Frankie Carle
- 9636 YOUNG LOVE
As played by Erroll Garner
- 9564 YOU'RE THE CREAM IN MY COFFEE
As played by Gene Kerwin

AS PLAYED BY FATS WALLER:

- Q-247 A-TISKET, A-TASKET
 - Q-223 CHRISTOPHER COLUMBUS
 - Q-249 THE FLAT FOOT FLOOGEE
 - Q-195 NO SWINGIN' IN HERE
 - 6155 YOUR FEET'S TOO BIG
- (For genuine Waller rolls see 'Best Of The 20's')

MARCHES & PATRIOTIC

- XP-106-A ALL-TIME FOOTBALL FAVORITES
On Wisconsin; Down The Field (Yale)
- 183 AMERICA (My Country 'Tis Of Thee)
- 7813 AMERICA THE BEAUTIFUL
- 4961 ANCHORS AWEIGH
- 7656 ARMY AIR CORPS
- 1454 BATTLE HYMN OF THE REPUBLIC
- 7619 CAISSONS GO ROLLING ALONG
- R-245 EL CAPITAN
- 33-372 COLONEL BOGEY (River Kwai March)
- 3570 COLUMBIA, GEM OF THE OCEAN
- 7024 GOD BLESS AMERICA
- 7344 IT'S A LONG WAY TO TIPPERARY
- Q-1012 MARCHING WITH DIXY
Played by composer Frank Adams
- R-253 MARCH KING MEDLEY
Washington Post; Semper Fidelis
- 7995 MARINES' HYMN
- 3463 NOTRE DAME VICTORY MARCH
- 3378 ON WISCONSIN
- Q-163 OVER THERE
- C-1031-A POMP AND CIRCUMSTANCE
- 9502 RAMBLIN' WRECK (from Georgia Tech)
- 33-372 RIVER KWAI MARCH (Colonel Bogey)
- 3726 SEMPER FIDELIS
- 9563 SEVENTY-SIX TROMBONES
- Q-176 STARS AND STRIPES FOREVER
- 182 STAR-SPANGLED BANNER
- 4929 STEIN SONG (University of Maine)
- 9950 STOUT-HEARTED MEN
- 10-235 STRIKE UP THE BAND FOR UCLA
- 10-679 THIS LAND IS YOUR LAND
- 9620 THUNDER AND BLAZES
- 3477 UNDER THE DOUBLE EAGLE
- Q-274 THE VICTORS (U of M)
- 3038 WASHINGTON POST MARCH
- Q-275 WE'RE LOYAL TO YOU ILLINOIS
- 7681 YANKEE DOODLE BOY (Cohan)
- 223 YANKEE DOODLE/WHEN JOHNNY COMES MARCHING HOME
- 7688 YOU'RE A GRAND OLD FLAG

The Best-Selling Rolls In The World! Q-R-S TOP 100

Do You Have Them All?

- 1.10-697 NEW YORK, NEW YORK
- 2.10-093-A CHRISTMAS GREETINGS
- 3.10-761 CHARIOTS OF FIRE
- 4.10-642 MUSIC BOX DANCER
- 5.10-518 THE ENTERTAINER (from "The Sting")
- 6. XP-129-B SOUND OF MUSIC MEDLEY TO ALL THE GIRLS I'VE LOVED BEFORE
- 7.10-808 HAPPY BIRTHDAY (Medley)
- 8.8312 WHITE CHRISTMAS
- 9.7742 SOMEWHERE MY LOVE
- 10.10-090 WE ARE THE WORLD
- 11.10-829 MICHAEL JACKSON HITS
- 12. XP-222-A AMAZING GRACE
- 13.10-481 MEMORY (from "Cats")
- 14.10-787 GERSHWIN MEDLEY
- 15. CEL-121-B MAPLE LEAF RAG
- 16.9725 BEER BARREL POLKA
- 17.7009 SWEET GEORGIA BROWN
- 18. Q-177 IT'S A SMALL WORLD
- 19.10-378 SEND IN THE CLOWNS
- 20.10-568 KENNY ROGERS HITS
- 21XP-188-C CHRISTMAS SONG (Chestnuts Roasting)
- 22.9934 HOW GREAT THOU'ART
- 23.9707 FLASHDANCE...WHAT A FEELING
- 24.10-792 SILVER BELLS
- 25.8897 YOU LIGHT UP MY LIFE
- 26.10-603 RUDOLPH, THE RED-NOSED REINDEER
- 27.8580 I'D LIKE TO TEACH THE WORLD TO SING
- 28.10-462 DUELLING BANJOS
- 29.10-497 FROSTY THE SNOWMAN
- 30.8681 WHEN IRISH EYES ARE SMILING
- 31. Q-182 THE OLD PIANO ROLL BLUES
- 32. Q-184 ANNIE MEDLEY, Pt. 1
- 33. XP-180-B SILENT NIGHT
- 34.3317 ELVIRA
- 35.10-728 SANTA CLAUS TIME
- 36.1553-A WHITE CHRISTMAS MEDLEY
- 37. CEL-114-B WAYLON & WILLIE
- 38. XP-213-B TIE A YELLOW RIBBON 'ROUND THE OLD OAK TREE
- 39.10-501 FAME
- 40.10-715 RAINDROPS KEEP FALLIN' ON MY HEAD
- 41.10-380 ALEXANDER'S RAGTIME BANQUET
- 42.3070 GREENSLEEVES (What Child Is This)
- 43. CEL-185-A THE ROSE
- 44.10-692 JINGLE BELL ROCK
- 45.10-101 EDELWEISS
- 46.10-135 AIN'T SHE SWEET
- 47. Q-111 LAND OF THE CHRISTMAS STAR
- 48. XP-1013-B BOOGIE WOOGIE (Solo)
- 49.7882 THE HILL STREET BLUES
- 50.10-738 THEME FROM ICE CASTLES
- 51.10-773 YOU ARE THE SUNSHINE OF MY LIFE
- 52.10-737 DO YOU HEAR WHAT I HEAR
- 53.10-169 PUTTIN' ON THE RITZ
- 54. Q-253 UPTOWN GIRL
- 55.10-803 IT'S BEGINNING TO LOOK A LOT LIKE CHRISTMAS
- 56.8795 BOOGIE WOOGIE BUGLE BOY
- 57.10-505 BEATLES HITS, Vol. 1
- 58. XP-231-C GLENN MILLER HITS, Vol. 1
- 59. XP-195-C OKLAHOMA! MEDLEY
- 60. XP-121-B BABY FACE
- 61. Q-180 STARS & STRIPES FOREVER
- 62. Q-176 ISLANDS IN THE STREAM
- 63.10-798 FORTY-SECOND STREET
- 64.10-346 TWELVE DAYS OF CHRISTMAS
- 65.9989 SHINE ON HARVEST MOON
- 66.5206 SLEIGH RIDE
- 67.9283 IN THE MOOD
- 68.7118 O HOLY NIGHT
- 69.3802 TWELFTH STREET RAG
- 70.1188 LULLABY OF BROADWAY
- 71. Q-220 STAR WARS THEME
- 72.10-606 ALWAYS ON MY MIND
- 73.10-763 BRIDGE OVER TROUBLED WATER
- 74.10-390 WIZARD OF OZ
- 75. XP-217-B BYE BYE BLACKBIRD
- 76. Q-179 SWANEE
- 77. Q-122 JOHN DENVER HITS
- 78. XP-189-C TAKE ME HOME, COUNTRY ROADS
- 79.10-453 NIGHT AND DAY
- 80.5537 FIVE FOOT TWO, EYES OF BLUE
- 81.8514 BLUE DANUBE WALTZ
- 82.3034 YOUR CHEATIN' HEART
- 83.8938 MACK THE KNIFE
- 84.9704 FRANK SINATRA HITS
- 85. XP-226-C ELVIS PRESLEY MEDLEY
- 86. XP-179-B THEMES FROM E.T.
- 87.10-775 WEDDING SONG (There Is Love)
- 88.10-778 EVERGREEN
- 89.10-583 AULD LANG SYNE
- 90.1249 IRVING BERLIN MEDLEY
- 91. XP-101-B YOU NEEDED ME
- 92.10-635 FEELINGS
- 93.10-547 ANNIE MEDLEY, Pt. 2
- 94. XP-181-B POLKA MEDLEY
- 95. XP-229-C CHARLESTON
- 96. Q-133 UP WHERE WE BELONG
- 97.10-779 ENDLESS LOVE
- 98.10-735 NINE TO FIVE
- 99.10-711 THE GAMBLER
- 100.10-641

RAGTIME, BLUES, & DIXIELAND!

- 9239 ACE IN THE HOLE
- 8535 BALLIN' THE JACK
- 6233 BASIN STREET BLUES
- 7324 BEAT ME DADDY, EIGHT TO THE BAR
- 8825 BLACK AND WHITE RAG
- 9900 BLACK BOTTOM STOMP (Jelly Roll Morton)
- 7576 BLUES IN THE NIGHT (My Mama Done Told Me)
- 7882 BOOGIE WOOGIE (Original) (piano solo)
- 5719 BUGLE CALL RAG
- 8124 BUMBLE BEE BOOGIE
- 10-058 BYE BYE BLUES
- 9299 CARLE BOOGIE
- 9682 COPENHAGEN (Dixieland)
- 7739 COW COW BOOGIE
- 8460 DILL PICKLES RAG
- 8770 DOWN YONDER (Ragtime)
- 2779 HARD-HEARTED HANNAH
- 8955 HELLO! MA BABY (Ragtime)
- 9358 HONKY TONK (Boogie)
- 7635 JERSEY BOUNCE
- 8447 JINGLE BELLS BOOGIE
- 8572 JOHNSON RAG
- 9595 KING PORTER STOMP (Jelly Roll Morton)
- 8706 LITTLE ROCK GETAWAY
- 7308 MAPLE LEAF RAG (Played by J. Lawrence Cook)
- 3269 MILENBERG JOYS (Jelly Roll Morton)
- 9099 MISSISSIPPI MUD
- 9078 MUSKRAT RAMBLE (Dixieland)
- 8626 THE OLD PIANO ROLL BLUES (Played by Dick Watson)
- Q-184 THE OLD PIANO ROLL BLUES (Played by J. Lawrence Cook)
- 8807 RAGTIME MELODY
- 8757 RHUMBA BOOGIE
- 4915 ST. JAMES INFIRMARY BLUES
- 4926 ST. LOUIS BLUES
- 7971 ST. LOUIS BLUES BOOGIE
- 7368 SCRUB ME MAMA, WITH A BOOGIE BEAT
- 8641 SPAGHETTI RAG
- 5205 SUGAR BLUES
- 9032 SOUTH RAMPART STREET PARADE
- 5353 TIGER RAG
- 1188 TWELFTH STREET RAG
- 5416 WABASH BLUES
- 8146 WOODCHOPPERS' BALL
- 6155 YOUR FEET'S TOO BIG (Fats Waller)

BEST OF THE TWENTIES

Here they are -- the rolls that made the Twenties! Reissued from the rare Q-R-S originals, each contains all of the lyrics and that special, matchless razz-ma-tazz style that made Q-R-S the world's leader in piano roll production.

- Q-111 AIN'T SHE SWEET
Played by Fred Parsons
- Q-268 AIN'T WE GOT FUN
Played by Pete Wendling
- Q-269 ALABAMY BOUND
Played by Pete Wendling
- Q-157 APRIL SHOWERS
Played by Ohman & Arden 12/21
- Q-180 BABY FACE
Played by Victor Arden 9/26
- 1738 BALTIMORE BUZZ
Played by James P. Johnson 12/21
- Q-181 BIRTH OF THE BLUES
Played by Victor Arden 10/26
- Q-112 BLUE SKIES
- Q-101 BLUIN' THE BLUES
Played by J. Russel Robinson
- Q-179 BYE BYE BLACKBIRD
Played by Victor Arden 6/26
- 1785 CANADIAN CAPERS
Played by Max Kortlander 2/22
- Q-113 CAROLINA IN THE MORNING
Played by Max Kortlander 12/22
- Q-129 CAROLINA SHOUT
Played by James P. Johnson
- Q-133 CHARLESTON
Played by James P. Johnson
- Q-1004 CHARLESTON RAG
Played by composer, Eubie Blake
- Q-114 CHARLIE MY BOY
Played by Lee Sims
- Q-188 CHICAGO (That Toddling Town)
Played by Max Kortlander 10/22
- Q-138 CLEARING HOUSE BLUES
Played by Thomas (Fats) Waller
- Q-168 DARKTOWN STRUTTERS' BALL
Played by Baxter & Kortlander 2/17
- Q-102 DILL PICKLES RAG
- Q-135 DON'T MESS WITH ME
Played by James P. Johnson
- Q-131 ECCENTRICITY
Played by James P. Johnson
- Q-151 EIGHTEENTH STREET STRUT
Played by Thomas (Fats) Waller
- Q-101 FIVE FOOT TWO, EYES OF BLUE
Played by J. Lawrence Cook 1/26
- Q-173 FOR ME AND MY GAL
Played by Pete Wendling 8/17
- Q-186 FRANKIE & JOHNNY
Played by Max Kortlander 8/23
- Q-130 HARLEM STRUT
Played by James P. Johnson
- Q-193 HINDUSTAN
Played by Baxter & Kortlander 8/18
- Q-191 HOW YOU GONNA KEEP 'EM
DOWN ON THE FARM?
Played by Baxter & Kortlander 4/19
- Q-152 IF I COULD BE WITH YOU
(One Hour Tonight)
Played by Thomas (Fats) Waller &
James P. Johnson
- Q-147 I'M COMING VIRGINIA
Played by Thomas (Fats) Waller
- XP-194- AL JOLSON HITS
Swanee; My Mammy; April Showers
- Q-162 K-K-K-KATY
Played by Kortlander & Robinson 11/18
- Q-1009 (Keep Your) SUNNY SIDE UP
Played by Pauline Alpert
- Q-158 LAST NIGHT ON THE BACK PORCH
Played by Pete Wendling 11/23
- Q-137 LAUGHIN' CRYIN' BLUES
Played by Thomas (Fats) Waller
- Q-116 LET ME CALL YOU SWEETHEART
Played by Scott & Watters 1/23
- Q-155 LET THE REST OF THE WORLD GO BY
Played by Lee S. Roberts 12/19
- Q-118 MAKIN' WHOOPIE
- Q-160 MAMA'S GONNA SLOW YOU DOWN
Played by Pete Wendling 11/23
- Q-156 MAMMY
Played by Pete Wendling 2/21
- Q-141 MARGIE
Played by composers J. Russel Robinson
and Con Conrad
- Q-105 MEMPHIS BLUES
Played by Pete Wendling
- Q-171 MISSOURI WALTZ
Played by Baxter & Kortlander 4/17
- Q-159 MR. JELLY LORD
Played by 'Jelly Roll' Morton
- Q-169 MOONLIGHT AND ROSES
Played by Harold Scott 3/25
- Q-119 MY MAN
Played by Pete Wendling 8/21
- Q-139 NOBODY BUT MY BABY
Played by Thomas (Fats) Waller
- Q-146 OH! BY JINGO
Played by Paul Loraine
- Q-184 THE OLD PIANO ROLL BLUES
Played by J. Lawrence Cook 6/50
- Q-132 OLE MISS BLUES
Played by James P. Johnson
- Q-203 OLE MISS RAG
Played by Scott Joplin

- Q-163 OVER THERE
Played by Baxter & Kortlander 10/17
- Q-120 PRETTY BABY (formerly Imperial)
- Q-202 PRETTY BABY
Played by Charlie Straight
(The first Q-R-S Word Roll)
- XP-233-B ROARING TWENTIES PARTY
MEDLEY
Played by Wendling, Redding,
and Sims
- Q-121 RED HOT MAMA
Played by Charlie Straight 7/24
- Q-166 ST. LOUIS BLUES
Played by J. Russel Robinson 9/20
- Q-145 SAY IT WITH MUSIC
Played by Arden & Kortlander 11/21
- Q-164 SECOND HAND ROSE
Played by Victor Arden 9/21
- Q-172 SIDEWALKS OF NEW YORK
Played by Scott & Watters 11/25
- Q-178 SLEEPY TIME GAL
Played by Harold Scott 1/26
- Q-170 SMILES
Played by Max Kortlander and
the composer, Lee S. Roberts
- Q-108 SNAKE HIPS
Played by Thomas (Fats) Waller
- Q-190 SOME OF THESE DAYS
Played by J. Lawrence Cook 3/35
- 3352 SQUEEZE ME
Played by Thomas (Fats) Waller 2/26
- Q-176 STARS AND STRIPES FOREVER
- Q-214 STUMBLING
Played by Kortlander, Arden, and
the composer, Zez Confrey
- Q-140 SUGAR BLUES
Played by composer Clarence Williams
- Q-1007 SWANEE
Played by composer George Gershwin
- Q-122 SWANEE
Played by Max Kortlander 3/20
- Q-177 SWEET GEORGIA BROWN
Played by Pete Wendling 6/25
- 2270 'TAIN'T NOBODY'S BIZNESS IF I DO
Played by Thomas (Fats) Waller 7/23
- Q-175 TEA FOR TWO
Played by J. Lawrence Cook 11/24
- Q-161 TELL ME (Why Nights Are Lonesome)
Played by Lee S. Roberts and
the composer, Max Kortlander
- Q-165 THAT OLD GANG OF MINE
Played by Victor Arden 9/23
- Q-123 THEN I'LL BE HAPPY
Played by Lee Sims
- Q-124 THERE'S A RAINBOW ROUND
MY SHOULDER
- Q-125 THREE O'CLOCK IN THE MORNING
- Q-199 TIP-TOE THROUGH THE TULIPS
Played by Max Kortlander 11/29
- Q-126 TOOT, TOOT, TOOTSIE
Played by Wallace Bradley
- Q-167 TWELFTH STREET RAG
Played by Max Kortlander 9/20
- Q-127 WAY DOWN YONDER IN NEW
ORLEANS
Played by Pete Wendling 12/22
- Q-182 WHEN IRISH EYES ARE SMILING
Played by Phil Ohman
- Q-183 WHEN THE RED, RED ROBIN
Played by Arden & Kortlander 8/26
- Q-174 WHO'S SORRY NOW
Played by Osborne & Howe 5/23
- Q-110 YOU'VE GOT TO SEE MAMA
EV'RY NIGHT
Played by Max Kortlander

SILENT MOVIE MUSIC



Mr. & Mrs. Rudolph Valentino enjoy a Q-R-S roll. You may not recognize the titles, but these rolls contain the best-loved mood music from the days of the silent screen!

The Classic Tear Jerker-

80-139-A HEARTS AND FLOWERS

The Lone Ranger Theme-

90-124-A WILLIAM TELL OVERTURE

Circus Music-

9620 THUNDER AND BLAZES

Fairyland Frolics-

C-109-A SPRING SONG

BEST OF THE THIRTIES

You're sure to enjoy the 30's sound with these reissued favorites from those classic movie musicals, played by the inimitable J. Lawrence Cook!

All rolls in this list are regular price.

- Q-232 ALL I DO IS DREAM OF YOU
from 'Sadie McKee'
- Q-207 ANIMAL CRACKERS IN MY
SOUP from 'Curly Top'
- Q-247 A-TISKET, A-TASKET
As played by 'Fats' Waller
- Q-216 BROTHER CAN YOU SPARE
A DIME from 'Americana'
- Q-223 CHRISTOPHER COLUMBUS
As played by 'Fats' Waller
- Q-252 DARN THAT DREAM
from 'Swingin' The Dream'
- 10-346 FORTY-SECOND STREET
from 'Forty-Second Street'
- Q-249 THE FLAT-FOOT FLOOGEE
As played by 'Fats' Waller
- Q-259 HEART AND SOUL
- Q-281 JUST A GIGOLO (Orig. Q-R-S
5087)
Played by Max Kortlander
- Q-226 I LIKE MOUNTAIN MUSIC
Introduced by Ethel Shutta
- Q-246 INKA DINKA DOO
from 'Palooka'
- Q-212 ISN'T THIS A LOVELY DAY
from 'Top Hat'
- Q-250 IT DON'T MEAN A THING
(If It Ain't Got That Swing)
- Q-282 I AIN'T GOT NOBODY (Orig.
Q-R-S 3293)
Played by J. Lawrence Cook
- Q-209 A LITTLE BIT INDEPENDENT
- Q-206 LOOKIE, LOOKIE, LOOKIE,
HERE COMES COOKIE
from 'Love In Bloom'
- Q-220 LULLABY OF BROADWAY
from 'Gold-Diggers of 1935'
- Q-255 MEAN TO ME
- Q-235 NEVERTHELESS
(I'm In Love With You)
- Q-270 NICE WORK IF YOU CAN GET IT
from 'Damsel In Distress'
- Q-195 NO SWINGIN' IN HERE
As played by 'Fats' Waller
- Q-228 NOW'S THE TIME TO
FALL IN LOVE
Introduced by Eddie Cantor
- Q-253 PUTTIN' ON THE RITZ
from 'Puttin' On The Ritz'
- Q-225 SINGIN' IN THE BATHTUB
from 'Show Of Shows'
- Q-244 STARS FELL ON ALABAMA
Introduced by the Morin Sisters
- Q-254 STOMPIN' AT THE SAVOY
Introduced by Benny Goodman
- Q-256 THEY CAN'T TAKE THAT AWAY
FROM ME
- Q-238 THREE LITTLE FISHIES
(Iddy Biddy Poo)
- Q-210 TOP HAT, WHITE TIE & TAILS
from 'Top Hat'
- Q-222 WHERE THE BLUE OF
THE NIGHT
Introduced by Bing Crosby
- Q-215 WHO'S AFRAID OF
THE BIG BAD WOLF?
from 'The Three Little Pigs'
- Q-257 WILLOW WEEP FOR ME
- Q-234 WRAP YOUR TROUBLES
IN DREAMS
- Q-211 YOU'RE AN OLD SMOOTHIE
from 'Take A Chance'
- Q-245 YOU ARE MY LUCKY STAR
from 'Broadway Melodies of 1936'



Vocalstyle

HOME MINSTREL SERIES

Each roll contains reproductions of the original Joke Sheets and instructions for performing your own Minstrel Show at home! Great Old-Time Fun!

XP-168-B HOME MINSTREL SERIES No. 1

1. Opening Chorus
2. Darktown Is Out Tonight
3. Just Break The News To Mother
4. Lindy
5. Carry Me Back To Old Virginny
6. Is Everybody Happy

XP-169-B HOME MINSTREL SERIES No. 2

1. Opening Chorus
2. Lazy Moon
3. Sweet Adeline
4. Mirandy
5. Massa's In The Cold, Cold Ground

INTERNATIONAL WORD ROLLS

Lyrics in a variety of foreign languages!

FRENCH

- 9525 AUTUMN LEAVES
CEL-130-A AUTUMN LEAVES
Played by Roger Williams
10-300 JE T'APPARTIENS
(Let It Be Me)
Q-1009 (Keep Your) SUNNY SIDE UP
10-517 LE MORIBOND
(Seasons In The Sun)
Q-119 MON HOMME (My Man)
9946 QUE RESTE-TIL DE NOS
AMOURS? (I Wish You Love)
8417 LA VIE EN ROSE

ITALIAN

- 9245 ARRIVEDERCI ROMA
200-494-A FAVORITE ITALIAN SONGS
1. Maria, Mari
2. O Sole Mio
3. Ciribiribin
4. Funiculi, Funicula
WF-9947 MALLA FEMMENA
10-046 TARANTELLA (Instrumental)
7167 TORNA A SORRIENTO
(Return To Sorriento)
9608 VOLARE
(Nel-Blu, di Pinto di Blu)

GERMAN

- 9817 DU, DU LIEGST MIR
IM HERZEN
WF-9520 LICHTENSTEINER POLKA

SPANISH

- 7066 ALLA EN EL RANCHO GRANDE
7894 BESAME MUCHO
7749 BRAZIL
9971 CUANDO CALIENTA EL SOL
(Love Me With All Your Heart)
10-547 ¿DIME? (Feelings)
9018 GRANADA
10-542 LOVE WILL KEEP US TOGETHER
2584 CIELTO LINDO

POLISH

- WF-6800 BARBARA POLKA
10-527 MOJA DROGA JA CIE KOCHEM
(My Melody Of Love)

CANADIAN

- 10-237 OH CANADA!

BRITISH

- WF-183 GOD SAVE THE QUEEN

HEBREW & YIDDISH

- BEI MIR BISTU SCHOEN
(See Andrews Sisters)
10-094-A CHANUKAH MELODIES
1. Rock Of Ages (Let Our Song etc.)
2. The Dreidel Song
3. Chanukah Song
4. Who Can Retell?
5. Sevivon
6. Rock Of Ages (Reprise)
9943 HAVA NAGILAH
WF-10-444 KOL NIDRE
10-130 MY YIDDISHE MOMME
9867 SHALOM ("Milk And Honey")

INTERNATIONAL

- 10-378 IT'S A SMALL WORLD
(English, Swedish, Italian, and
Japanese lyrics)

Everybody's Irish On ST. PATRICK'S DAY

- 2458 DANNY BOY (Londonderry Air)
447 DAUGHTER OF ROSIE O'GRADY
6574 DID YOUR MOTHER COME
FROM IRELAND
8448 GALWAY BAY
101-034 IRISH JIGS
9468 IRISH WASHERWOMAN
2725 A LITTLE BIT OF HEAVEN
(How Ireland Got Its Name)
2458 LONDONDERRY AIR (Danny Boy)
7293 MacNAMARA'S BAND
200-428 MEDLEY OF FAVORITE
IRISH SONGS
101-007 MEDLEY OF IRISH JIGS
204 MY WILD IRISH ROSE
8000 TOO-RA-LOO-RA-LOO-RA
284 WEARIN' OF THE GREEN
Q-182 WHEN IRISH EYES ARE SMILING

May We Have The Next DANCE?

Waltzes

- 7027 ARTIST'S LIFE (Kunstlerleben)
3034 BLUE DANUBE WALTZ
7303 EMPEROR WALTZ
7405 SWEETHEART WALTZ
30-082 TALES FROM THE VIENNA WOODS
7028 VIENNA LIFE (Wiener Blut)

Polkas

- WF-6800 BARBARA POLKA
7009 BEER BARREL POLKA
(Roll Out The Barrel)
7452 CLARINET POLKA
7409 FRIENDLY TAVERN POLKA
7080 HELENA POLKA
8958 JUST ANOTHER POLKA
WF-9520 LICHTENSTEINER POLKA
8578 MERRY CHRISTMAS POLKA
8469 MORE BEER POLKA
7654 PENNSYLVANIA POLKA
XP-229-C POLKA FAVORITES
1. Pennsylvania Polka
2. Beer Barrel Polka
3. Too Fat Polka
8656 TIC-TOC POLKA
8321 TOO FAT POLKA

Square Dances

- 8677 SQUARE DANCE MEDLEY
1. Old Folks At Home
2. Listen To The Mocking Bird
3. Buffalo Gals
4. Turkey In The Straw
VIRGINIA REEL

Latin

- 7894 BESAME MUCHO (Rhumba)
8818 BLUE TANGO (Leroy Anderson)
7749 BRAZIL
5827 CARIOCA (Tango)
5975 LA CUCHARACHA (Rhumba)
WF-9189 LA CUMPARSITA (Tango)
8601 ENJOY YOURSELF (Samba)
9018 GRANADA
7394 GREEN EYES (Rhumba)
9054 HERNANDO'S HIDEAWAY (Tango)
8053 JALOUSIE (Jealousy) (Tango)
8830 MALAGUENA
9638 MEXICAN HAT DANCE
8832 PERFIDIA ((Rhumba)
7066 EL RANCHO GRANDE
9702 TEA FOR TWO CHA CHA
7979 TICO TICO (Samba)
8026 YOU BELONG TO MY HEART
7426 YOURS (Rhumba)

Others

- 8535 BALLIN' THE JACK
3637 BLACK BOTTOM
9637 CAN-CAN (Offenbach)
Q-133 CHARLESTON
10-541 THE HUSTLE
2070 SISTER KATE (I Wish I Could
Shimmy Like My)
9871 THE STRIPPER
Q-122 SWANEE (One Step)
9840 THE TWIST
4083 THE VARSITY DRAG

You'll Have A Riot With These PLAY-ALONG ROLLS!

- 9960 CHOPSTICKS
9938 DOWN AT PAPA JOE'S

BEST OF THE FORTIES

- Q-261 "A" YOU'RE ADORABLE
Q-262 CHICKERY CHICK
Q-280 CIVILIZATION (Bongo, Bongo, Bongo)
Q-258 I DON'T WANT TO WALK WITHOUT
YOU
Q-277 I'M MAKING BELIEVE
Q-279 I'VE GOT A CRUSH ON YOU
Q-260 MAIRZY DOATS AND DOZY DOATS
Q-276 MANANA
Q-267 RUM AND COCA COLA
Q-266 SKYLARK
Q-272 TANGERINE
Q-265 THE TROLLEY SONG
(Clang, Clang, Clang)
Q-278 WHAT'S NEW
Q-273 WOODY WOODPECKER

LONG-PLAY, BIG BAND SPECIALS!

(see also "NEW RELEASES" on cover)

- XP-219-B ANDREWS SISTERS MEDLEY
1. Don't Sit Under The Apple Tree
2. Apple Blossom Time
3. Bel Mir Bistu Schoen
XP-225-C BENNY GOODMAN HITS
1. Gotta Be This Or That
2. Stompin' At The Savoy
3. One O'Clock Jump (solo)
XP-218-B HARRY JAMES MEDLEY
1. I've Heard That Song Before
2. It's Been A Long, Long Time
3. Ciribiribin
XP-221-B ETHEL MERMAN MEDLEY
1. There's No Business Like
Show Business
2. You're Just In Love
3. I Got Rhythm
XP-195-C GLENN MILLER HITS, Vol. 1
1. Moonlight Serenade
2. Tuxedo Junction
3. Little Brown Jug
4. String Of Pearls
XP-224-C GLENN MILLER HITS, Vol. 2
1. At Last
2. Chattanooga Choo Choo
3. I've Got A Gal In Kalamazoo
XP-241-B GLENN MILLER HITS, VOL. 3
XP-227-C MILLS BROTHERS MEDLEY
1. Lazy River
2. Paper Doll
3. Yellow Bird
XP-228-C TOMMY DORSEY MEDLEY
1. I'm Getting Sentimental
Over You
2. Beale Street Blues
3. Boogie Woogie (solo)

All The Oscar-Winners! ACADEMY AWARDS



- 6015 THE CONTINENTAL (1934)
Q-220 LULLABY OF BROADWAY (1935)
6598 SWEET LILIANI (1937)
9461 THANKS FOR THE MEMORY (1938)
9190 OVER THE RAINBOW (1939)
10-145 WHEN YOU WISH UPON A STAR (1940)
7742 WHITE CHRISTMAS (1942)
9330 YOU'LL NEVER KNOW (1943)
7943 SWINGIN' ON A STAR (1944)
8057 IT MIGHT AS WELL BE SPRING (1945)
8036 ON THE ATCHESON, TOPEKA, AND
THE SANTA FE (1946)
8184 ZIP-A-DEE DOO DAH (1947)
8519 BABY IT'S COLD OUTSIDE (1949)
8643 MONA LISA (1950)
8873 HIGH NOON (1952)
9014 SECRET LOVE (1953)
9053 THREE COINS IN THE FOUNTAIN (1954)
9198 LOVE IS A MANY-SPLENDORED
THING (1955)
9328 WHATEVER WILL BE, WILL BE (1956)
9517 ALL THE WAY (1957)
9825 GIGI (1958)
10-245 HIGH HOPES (1959)
9768 NEVER ON SUNDAY (1960)
9842 MOON RIVER (1961)
9895 DAYS OF WINE AND ROSES (1962)
9898 CALL ME IRRESPONSIBLE (1963)
10-007 CHIM CHIM CHER-EE (1964)
10-051 SHADOW OF YOUR SMILE (1965)
10-107 BORN FREE (1966)
10-188 TALK TO THE ANIMALS (1967)
10-308 WINDMILLS OF YOUR MIND (1968)
10-380 RAINDROPS KEEP FALLIN'
ON MY HEAD (1969)
10-433 FOR ALL WE KNOW (1970)
10-502 THE MORNING AFTER (1972)
10-516 THE WAY WE WERE (1973)
10-583 EVERGREEN (1976)
10-603 YOU LIGHT UP MY LIFE (1977)
10-629 LAST DANCE (1978)
10-715 FAME (1980)
10-736 ARTHUR'S THEME (1981)
10-761 CHARLOTS OF FIRE (1981)
10-779 UP WHERE WE BELONG (1982)
10-792 FLASHDANCE...WHAT A FEELING
(1983)
10-822 I JUST CALLED TO SAY I LOVE
YOU (1984)
10-846 SAY YOU, SAY ME (1985)



SAVE THESE SEALS!

Big savings on special offers! Q-R-S Proof of Purchase seals can be found in the thumb notch or on the bottom of the box of every new Q-R-S roll. (Used rolls do not qualify.)

Special offers are listed in the Q-R-S NEWS, the world's only piano roll newspaper. Be sure to pick up a copy from your dealer—or subscribe FREE with the form on p. 23.

CLASSIEST CLASSICS



GET THE GRAMMIES!



MUSIC FOR HAPPY CHILDREN

- 232-B AMADEUS
 - 1. Piano Concerto in D minor, K.466, 2nd movement
 - 2. Concerto for Two Pianos, K.365, 3rd movement
 - 3. Piano Concerto in E flat, K.482, 3rd movement
- C-137-A AN AMERICAN IN PARIS (Pt.1)
- C-138-A AN AMERICAN IN PARIS (Pt.2)
- 7027 ARTIST'S LIFE (Strauss)
- 64-530 ANVIL CHORUS (Verdi)
- C-101-A BARCAROLLE from "Tales of Hoffman" (Offenbach)
- 612-060-A BARCAROLLE (Anton Rubenstein)
- 3034 BLUE DANUBE WALTZ (Strauss)
- 60-590-A BOLERO (Ravel)
- 7510 BRAHMS' LULLABY
- 9637 CAN-CAN DANCE (Offenbach)
- 10-840 CANON IN D (Pachelbel)
- C-127-A CARMEN GRAND POTPOURRI
- 2584 CIELITO LINDO
- C-111-A CLAIR DE LUNE (Debussy)
- C-118-A CONCERTO in A minor, Op. 16, 1st movement (Grieg)
- C-121-A CONCERTO in B-Flat Minor (Tchaikowsky)
- C-139-A CONCERTO No.2 in C Minor, 1st Movement (Rachmaninoff)
- C-140-A CONCERTO No.2 in C Minor, 2nd Movement (Rachmaninoff)
- C-141-A CONCERTO No.3 in C Minor, 3rd Movement (Rachmaninoff)
- 7736 DAYBREAK ("Grand Canyon Suite") (Grove)
- 20-127-A ECHOES FROM THE METROPOLITAN OPERA HOUSE
 - 1. The Prophet 2. Aida 3. Cavalleria Rusticana 4. Boabdil 5. Tannhauser 6. Nibelungen 7. Pagliacci 8. William Tell
- C-135-A 1812 OVERTURE, Op.49 (Pt.1) (Tchaikowsky)
- 136-A 1812 OVERTURE, Op.49 (Pt.2) (Tchaikowsky)
- 803 EMPEROR WALTZ (Strauss)
- 63-210-A FANTASIE IMPROMPTU Op.66 (Chopin)
- 7956 FLIGHT OF THE BUMBLEBEE
- 10-768 FOR UNTO US A CHILD IS BORN (Handel)
- 2325 HALLELUJAH CHORUS from "Messiah" (Handel)
- C-103-A HUMORESQUE, Op. 101 No. 7 (Dvorak)
- C-120-A HUNGARIAN DANCE No.5 (Brahms)
- 6141 ITALIAN STREET SONG (Herbert)
- 10-817 JESU, JOY OF MAN'S DESIRING (Bach)
- 10-353 KITTEN ON THE KEYS (Confrey)
- R-103-A LIEBESTRAUM No. 3 (Liszt)
- 1731 MERRY WIDOW WALTZ (Lehar)
- 80701-A MINUET IN G (Beethoven)
- C-134-A MOONLIGHT SONATA Op. 27, No.2 1st movement (Beethoven)
- C-124-A MOONLIGHT SONATA Op. 27, No.2 2nd and 3rd movements
- 3411 NOLA (Felix Arndt)
- C-125-A NUTCRACKER SUITE (Pt.1) (Tchaikowsky)
- C-126-A NUTCRACKER SUITE (Pt.2) (Tchaikowsky)
- 739 O SOLE MIO (Di Capua)
- XP-205-B PIRATES OF PENZANCE
- 20-001-A POET AND PEASANT OVERTURE (Von Suppe)
- C-128-A POLONAISE in A-Flat, Op.53 (Chopin)
- 614-840-A POLONAISE in C-Sharp Minor, Op.26 No. 1 (Chopin)
- C-1031-A POMP AND CIRCUMSTANCE
- C-106-A PRELUDE in C-Sharp Minor, Op.3 (Rachmaninoff)
- C-1010-A RHAPSODIE HONGROISE No.2 (Liszt) Played by Paderewsky
- C-1005-A RHAPSODY IN BLUE (Pt.1) Played by George Gershwin
- 006-A RHAPSODY IN BLUE (Pt.2) Played by George Gershwin
- R-113-A RUSTLE OF SPRING (Sinding)
- 8361 SABRE DANCE from "Gayne Ballet Suite" (Khachaturian)
- 1736 SERENADE (Schubert)
- 10-772 SOMEWHERE IN TIME (18th variation from "Rhapsody On A Theme Of Paganini")(Rachmaninoff)

Song of the Year

- 9694 BATTLE OF NEW ORLEANS (1959)
- 9782 EXODUS (1960)
- 9842 MOON RIVER (1961)
- 9886 WHAT KIND OF FOOL AM I? (1962)
- 9895 DAYS OF WINE AND ROSES (1963)
- 9949 HELLO DOLLY! (1964)
- 10-051 SHADOW OF YOUR SMILE (1965)
- 10-061 MICHELLE (1966)
- 10-165 UP, UP AND AWAY (1967)
- 10-209 LITTLE GREEN APPLES (1968)
- 10-355 GAMES PEOPLE PLAY (1969)
- 10-390 BRIDGE OVER TROUBLED WATER (1970)
- 10-475 THE FIRST TIME EVER I SAW YOUR FACE (1972)
- 10-498 KILLING ME SOFTLY WITH HIS SONG (1973)
- 10-516 THE WAY WE WERE (1974)
- 10-568 SEND IN THE CLOWNS (1975)
- 10-558 I WRITE THE SONGS (1976)
- 10-583 EVERGREEN (1977)
- 10-603 YOU LIGHT UP MY LIFE (1977)
- 10-612 JUST THE WAY YOU ARE (1978)
- 10-699 SAILING (1980)
- 10-724 BETTE DAVIS EYES (1981)
- 10-786 ROSANNA (1982)
- 10-824 WHAT'S LOVE GOT TO DO WITH IT? (1984)

Record of the Year

- 9704 MACK THE KNIFE (1959)
- 9733 A SUMMER PLACE (1960)
- 9842 MOON RIVER (1961)
- 9887 IN SAN FRANCISCO (1962)
- 9895 DAYS OF WINE AND ROSES (1963)
- 9975 GIRL FROM IPANIMA (1964)
- 10-088 STRANGERS IN THE NIGHT (1966)
- 10-165 UP, UP AND AWAY (1967)
- 10-227 MRS. ROBINSON (1968)
- 10-317 AQUARIUS (1969)
- 10-390 BRIDGE OVER TROUBLED WATER (1970)
- 10-475 THE FIRST TIME EVER I SAW YOUR FACE (1972)
- 10-498 KILLING ME SOFTLY WITH HIS SONG (1973)
- 10-526 I HONESTLY LOVE YOU (1974)
- 10-542 LOVE WILL KEEP US TOGETHER (1975)
- 10-592 HOTEL CALIFORNIA (1977)
- 10-612 JUST THE WAY YOU ARE (1978)
- 10-699 SAILING (1980)
- 10-724 BETTE DAVIS EYES (1981)
- 10-786 ROSANNA (1982)
- XP-222-A MICHAEL JACKSON HITS (1983) Beat It; Billie Jean
- 10-824 WHAT'S LOVE GOT TO DO WITH IT? (1984)

Best Country-Western Song

- 10-210 GENTLE ON MY MIND (1967)
- 10-209 LITTLE GREEN APPLES (1968)
- 10-351 A BOY NAMED SUE (1969)
- 10-442 FOR THE GOOD TIMES (1970)
- 10-469 HELP ME MAKE IT THROUGH THE NIGHT (1971) (Hey, Won't You Play) ANOTHER SOMEBODY DONE SOMEBODY WRONG SONG (1975)
- 10-641 THE GAMBLER (1978)
- 10-677 YOU DECORATED MY LIFE (1979)
- 10-711 NINE TO FIVE (1981)
- 10-763 ALWAYS ON MY MIND (1982)
- 10-827 CITY OF NEW ORLEANS (1984)

Best Instrumental Theme

- 10-203 MISSION: IMPOSSIBLE (1967)
- 10-240 CLASSICAL GAS (1968)
- 10-455 SUMMER OF '42 (1971) (The Summer Knows)
- 10-518 THE ENTERTAINER (1974) (The Sting)
- 10-541 THE HUSTLE (1975)
- 10-606 STAR WARS (1977)
- 10-738 THE HILL STREET BLUES (Theme)(1981)

Classical, cont'd.

- XP-163-B SORCERER'S APPRENTICE (Dukas)
- C-109-A SPRING SONG Op.2, No.30 (Mendelssohn)
- 7405 SWEETHEART WALTZ (Strauss)
- 30-082 TALES FROM THE VIENNA WOODS (Strauss)
- C-122-A TRAUMEREI op.15 (Schumann)
- R-153 TWO GUITARS
- C-112-A UNFINISHED SYMPHONY No.8 in B Minor (Schubert)
- 7028 VIENNA LIFE (Strauss)
- 9390 WEDDING MARCH (Mendelssohn)
- 21-041-A WEDDING MARCH from "Lohengrin" (Here Comes The Bride) (Wagner)
- 90-124-A WILLIAM TELL OVERTURE

Q-207 XP-155-B

- ANIMAL CRACKERS IN MY SOUP
- CARNIVAL OF THE ANIMALS Delightful verses by humorist Ogden Nash, combined with the classic animal pieces by Saint-Saens!
 - 1. Introduction 2. Royal March of the Lions 3. Cocks and Hens 4. Wild Jackass 5. Turtles 6. Elephants 7. Kangaroos 8. Aquarium 9. Mules 10. Cuckoo in the Woods.
- 10-478 THE CANDY MAN
- 10282 CHITTY CHITTY BANG BANG
- 9960 CHOPSTICKS (Play-Along Roll)
- 9138 DAVY CROCKETT
- XP-235B DISNEY CLASSICS
- 9722 DO-RE-MI ("The Sound Of Music")
- 10-775 E.T. THEME
- 9160 HEY MR. BANJO
- 8737 I WHISTLE A HAPPY TUNE
- 10-462 I'D LIKE TO TEACH THE WORLD TO SING
- 9832 I'M POPEYE THE SAILOR MAN
- 4645 IN THE BIG ROCK CANDY MOUNTAINS
- 10-378 Walt Disney's IT'S A SMALL WORLD (English, Swedish, Italian, & Japanese)
- 7837 I'VE BEEN WORKIN' ON THE RAILROAD
- 10-305 KUM-BA-YAH
- XP-102-A MARY POPPINS (Medley)
 - 1. Chim-Chim Cher-ee 2. A Spoonful Of Sugar
- 9829 MICHAEL (Row The Boat Ashore)
- 10-503 MICKEY MOUSE CLUB MARCH
- 9719-A MOTHER GOOSE RHYMES No.1
 - 1. Mistress Mary 2. Jack & Jill 3. Baa, Baa, Black Sheep 4. Ding Dong Bell 5. Pussy Cat, Where Have You Been? 6. I Had A Little Doggie 7. Little Bo Peep
- 9757 MOTHER GOOSE RHYMES No.2
 - 1. Pussy Cat, Pussy Cat 2. Tom, Tom The Piper's Son 3. Bobby Shafto 4. Sing A Song Of Sixpence 5. Ding Dong Bell 6. Little Tommy Tucker.
- XP-2446 MUPPET MEDLEY
- 9267 OLD MacDONALD HAD A FARM
- 9938 PAPA JOE'S (Play Along Roll)
- 2031 PARADE OF THE WOODEN SOLDIERS
- 8625 PETER COTTONTAIL
- XP-145-B PINOCCHIO (Medley)
 - 1. When You Wish Upon A Star 2. I've Got No Strings 3. Little Wooden Head 4. Turn On The Old Music Box 5. Give A Little Whistle 6. Hi Diddle-Dee-Dee.
- 6305 POLLY WOLLY DOODLE
- 9910 PUFF (The Magic Dragon)
- 10-675 THE RAINBOW CONNECTION
- 10-412-A RUBBER DUCKIE (Rubber Duck Enclosed)
- XP-137-A SHIRLEY TEMPLE MEDLEY
 - 1. On The Good Ship Lollipop 2. Cod-fish Ball 3. Polly Wolly Doodle
- 10-500 SING (Sing A Song)
- 1950-A SINGING GAMES
 - 1. London Bridge 2. Itisket, Itasket 3. 'Round The Mulberry Bush 4. The Farmer In The Dell
- XP-146-B SNOW WHITE (Medley)
 - 1. Whistle While You Work 2. Heigh-Ho 3. Someday My Prince Will Come 4. One Song 5. With A Smile And A Song 6. I'm Wishing 7. Bluddle-Uddle Um-Dum
- XP-163-B THE SORCERER'S APPRENTICE (Story Roll with Poetry)
- 9993 SPOONFUL OF SUGAR
- 10-606 STAR WARS
- 1259 SWING MEDLEY NURSERY RHYMES
 - 1. Farmer in the Dell 2. Mary Had A Little Lamb 3. Twinkle, Twinkle Little Star
- 10-188 TALK TO THE ANIMALS
- 8689 TEDDY BEAR'S PICNIC
- 8923 THAT DOGGIE IN THE WINDOW
- 7221 TOYLAND (Victor Herbert)
- Q-215 WHO'S AFRAID OF THE BIG, BAD WOLF?
- XP-217-B THE WIZARD OF OZ
 - 1. Over The Rainbow 2. Munchkin Land 3. Ding-Dong! The Witch Is Dead 4. Lullaby League & Lollipop Guild 5. We're Off To See The Wizard 6. If I Only Had A Brain 7. The Merry Old Land Of Oz.
- 8184 ZIP-A-DEE DOO DAH

The Q-R-S Marketplace

The world's finest assortment of player piano accessories.

Suggested Retail Prices. (Slightly higher in Canada.)

SPECIAL BOOKS YOU'LL WANT TO OWN

NEW!

PLAYER PIANO SERVICING AND REBUILDING

This is it! The book no player piano owner should be without. Every aspect of the player maintenance and repair is covered in detail and thoroughly illustrated. Author Art Reblitz has spared no effort to make this the ultimate player piano manual. It contains 224 pages, and has



over 350 drawings and illustrations! Highest recommendation.
#BKS-16 (softbound) \$16.50
#BKS-17 (hardbound) \$24.95



PIANO SERVICING, TUNING AND REBUILDING

The companion Volume to Reblitz's *Player Piano Servicing & Rebuilding* (above), this much-needed book will thoroughly instruct you in how to put your *piano* in tip-top shape once you've finished the player action. The best book of its kind in the world today — for professionals as well as hobbyists. Hardbound.
#BKS-7 \$19.95

PLAYER PIANOS AND MUSIC BOXES

(formerly "Keys To A Musical Past")

With 50 pages of pictures and ads from "the good old days", this booklet is the biggest little bargain on the subject. Author Harvey Roehl conveys his enthusiasm for these mechanical musical miracles like no other writer. Softbound.
#BKS-4 \$5.75



PLAYER PIANO TREASURY

The best-loved book on the subject, this nostalgic scrapbook history of the player piano by Harvey Roehl includes a 10-page tour of the Q-R-S Factory! Beautiful full-color cover. Over 300 pages, softbound.
#BKS-5 \$16.95



THE FINEST SERVICE MANUALS & TEST ROLLS

88-NOTE TEST ROLL

A "must have" for maintaining your player piano in top condition. Tests 82 notes on the keyboard for response and repetition.
#RRP-12 \$4.75

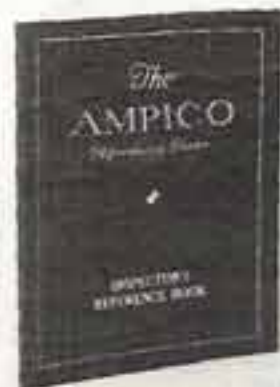

AMPICO SERVICE MANUAL

Superb reprint of the rare 1923 Ampico Service Manual for lucky Ampico owners. Use it with Ampico Test Roll listed below.
#BKS-8 \$3.50

AMPICO TEST ROLL

You cannot properly regulate your Ampico piano without this precision test roll and the Ampico Service Manual listed above. Expertly copied from the rare original.
#AMP-1002-A \$6.25

DUO-ART SERVICE MANUAL

Not to be confused with Duo Art players made since the 1950's, original Duo-Art pianos require special adjustments described only in this manual. Lovingly reproduced from the rare 1926 original.
#BKS-9 \$3.50



DUO-ART TEST ROLL (Illustrated)

For use with the Duo-Art Service Manual (above) for Duo-Art pianos made before the 1950's, this is the finest test roll ever produced. Drawings printed on the roll make your work easy. A thorough reproduction of a very rare roll.
#DA-1002-C \$7.95



WELTE-MIGNON SERVICE MANUAL

A fine reprint of the 1924 Welte-Mignon Service Manual for servicing and adjusting these excellent instruments. The all-important tubing diagrams are included. Use with the Welte Test Roll listed below.
#BKS-10 \$5.95

WELTE-MIGNON TEST ROLL

Indispensable for adjusting the Welte-Mignon piano. Use this accurate test roll with the Welte-Mignon Service Manual listed above.
#WEL-1002-A \$6.25

RECORDO TEST ROLL

If you own a Recordo-type piano (identified by the 5 slotted holes at each end of the tracker bar), here is its best friend: The original Recordo Test Roll, made by Q-R-S since the 1920's. Use it to achieve maximum expression from your piano.
#RRP-13 \$4.75



ORI-THEMATIC ROLL MAKER MANUAL

Make your own rolls! Simple, complete instructions and plans for making piano rolls at home — even if you don't read music. Learn what the holes mean and where to put them!
#BKS-11 \$4.95



1926 PIANO AND PLAYER PIANO BUYER'S GUIDE

(formerly *Presto Buyer's Guide*)
Curious about your player's history? Here's a reprint of the one and only book listing the hundreds of brands made in the 1920's with brief profiles of the manufacturers. Trace your piano's roots!
Softbound #BKS-1 \$14.50

ENCYCLOPEDIA OF AUTOMATIC MUSICAL INSTRUMENTS

A monumental book. Over 1,000 pages, hundreds of photographs and old ads, presenting in a single volume the entire fascinating history of the amazing machines that make music. Player violins, banjos, harps, and even entire orchestras, and of course all kinds of player pianos. You'll find Q-R-S mentioned in no less than 14 places — as befits the world's oldest and largest roll company!
Hardbound. #BKS-2 \$45.00



HOW TO PLAY LIKE A PLAYER PIANO

by Dick Watson
QRS roll artist Dick Watson reveals some of his trade secrets! Here's a collection of 11 favorite tunes, including *Margie* and *For Me An My Gal*, written out in real old-fashioned piano roll style. Tips on those special razz-ma-tazz effects dear to the hearts of player owners. Softbound.
#BKS-3 \$4.95

PARTY GOODS FOR PERFECT PARTIES

SING-ALONG SONGBOOKS

LIFE OF THE PARTY LYRIC BOOKLET

How many guests fit around the player piano? Only a handful! But now the whole room can sing along by following the words in their own lyric booklet. You get 175 favorite tunes and a handy index which lists them by Q-R-S roll number. The perfect solution! Another Q-R-S innovation.
#BKS-12 \$1.98



LIFE OF THE PARTY COMPANION SONGBOOK

Music, chords, and words to the 175 songs in the booklet above. For the song leader, pianist, guitarist, and those who like to go deluxe. Spiral bound.
#BKS-14 \$16.95

LIFE OF THE PARTY LYRIC BOOKLET II

The first Life Of The Party booklet was such a success we've added another! It's got 88 more universal favorites and a roll index, and we're proud to bring it to you. Unique and desirable.
#BKS-18 \$1.98

LIFE OF THE PARTY COMPANION SONGBOOK II

The sequel to one of our best ideas! Music, chords and words to all 88 songs in Life Of The Party Lyric Booklet II. Spiral bound for easiest use.
#BKS-19 \$16.95

IMPORTANT

PLEASE ORDER ALL ITEMS BY ITEM NUMBER.

All prices subject to change without notice.

KAZOOS



The original all-metal kazoo, and still the best. Eight shiny red beauties, the 1916 model, packaged in a Q-R-S roll box. Great fun for everyone who likes to make a musical racket now and then! Get a box for your next sing-along party.
#ACC-5 \$5.50

COASTERS



Highest quality plastic coasters, modelled after the rare Q-R-S phonograph records of the 1920's! Prevent rings on tabletops — and piano tops — with these handy, nostalgic novelties. Set of six. #ACC-3 \$2.95

WEARABLES

Q-R-S T-Shirts



A favorite for nearly 20 years! Finest quality all-cotton white T-shirts, with the Q-R-S Player Rolls are Better slogan permanently imprinted in red. Washable. Please state correct size and number when ordering.

SIZES:
Children 8, 10, 12
Adult S, M, L, XL

#TSC-1 \$4.95
#TSA-2 \$5.95

Q-R-S Belt Buckle

Originally made for us by the leading manufacturer, these big old-time belt buckles mark you as a person who accepts no substitutes — and demands genuine Q-R-S products. Treat yourself or a friend to one today. #ACC-7 \$6.50



STATE-OF-THE-ART PIANO ATTACHMENTS



DELUXE SUCTION BOX KIT FOR ELECTRIFICATION

Tired of foot-pumping? We offer the quietest, best-engineered suction box on the market today. Thousands of satisfied users! Simple instructions and everything you need to go electric — and the foot pump remains operational. Box fits inside the bottom of the piano, out of sight. On/off switch, volume control mount under keyboard. Do it yourself and save!
#ACC-11 \$140.00

Honky Tonk Attachment

The best way to get that old-fashioned 'honky-tonk' sound! For use on upright and spinet pianos, this device can be activated at will. Have your technician install it, or do it yourself if you're handy with simple tools. Instructions included. Note: The Q-R-S Player Piano comes equipped with a honky-tonk feature. This device cannot be installed in pianos equipped with a Peace Maker (below). Cannot be shipped overseas. #ACC-4 \$37.50

Peace Maker Muffler Rail

Prevent noise pollution! A Peace Maker is the only device of its kind we know of. It will make your upright or spinet player quieter, for small rooms or late night roll playing or practicing. Instructions for easy installation. Turn on and off at will! Note: The Q-R-S Player Piano is equipped with a volume control. This device cannot be installed in pianos equipped with a Honky Tonk Attachment (above). Cannot be shipped overseas. #ACC-12 \$35.95

SUPERIOR RECORDS, TAPES, & VIDEOS

Player Piano Records



The best in rare ragtime, early jazz, and other old-time rolls is now available on record! With co-operation from Q-R-S, these Biograph albums make it possible to have player music wherever there's a phonograph. Nostalgic record covers and excellent liner notes compliment these unique stereo albums. \$8.98 each

- BLP-1017Q ACADEMY AWARD WINNERS from Movie Musicals — 1934-1947.
- BLP-1011Q EUBIE BLAKE Blues & Ragtime, Vol. 1 1917-1921
- BLP-1012Q EUBIE BLAKE Blues & Spirituals
- BLP-1020Q HAPPY DAYS ARE HERE AGAIN from Musicals 1929-1948
- BLP-1003Q JAMES P. JOHNSON 1917-1921
- BLP-1009Q JAMES P. JOHNSON 1917 Vol. 2
- BLP-1025Q JOLSON SANG 'EM - Musical Nostalgia from Rare Piano Rolls
- BLP-1006Q SCOTT JOPLIN 1916, Vol. 1
- BLP-1008Q SCOT JOPLIN Ragtime, Vol. 2
- BLP-1010Q SCOTT JOPLIN Ragtime, Vol. 3
- BLP-1021Q THE MUSIC OF JEROME KERN
- BLP-1018Q MAKIN' WHOOPEE from Musicals 1928-1957
- BLP-1004Q JELLY ROLL MORTON 1924-1926
- BLP-1016Q JAMES SCOTT Classic Ragtime from Rare Piano Rolls
- BLP-1019Q THANKS FOR THE MEMORY from Musicals 1931-1943
- BLP-1002Q THOMAS "FATS" WALLER 1923-24, Vol. 1
- BLP-1005Q THOMAS "FATS" WALLER 1924-31, Vol. 2
- BLP-1015Q "FATS" WALLER Rare Piano Roll Solos, Vol. 3
- BLP-1001Q PARLOR PIANO 1917-1927

NEW!

Player Piano Cassettes!



Hear an absolutely super player piano on your tape player! We proudly present these brand new tapes, in response to numerous requests.

GOOD OLD-FASHIONED PLAYER PIANO MUSIC, VOL. 1

Seventeen rip-roaring renditions, including *Toot Toot Tootsie*, *Hello Ma Baby*, *Darktown Strutters' Ball*, and 14 others especially selected by expert Harvey Roehl for their foot-stomping appeal. #ACC-15 \$8.98

CHRISTMAS PLAYER PIANO MUSIC

Share your holiday cheer without moving your player piano to every Christmas party! Over 15 yuletide tunes, including all the favorites — *White Christmas*, *Jingle Bells*, *Winter Wonderland*, *The First Noel*, and much more. It's delightful! #ACC-14 \$8.98

The First-Ever Videocassette For Player Piano Fans!



Rudy Martin at Q-R-S Recording Piano.

PUNCHING A HOLE, PLAYING A ROLL

Ever wanted to see how a Q-R-S Roll is created? Ever wanted to see — and hear — some of the greatest roll-playing machines in the world? Machines you've read about in *Player Piano Treasury*? Now, in this professionally-produced video, you'll tour Q-R-S in Buffalo and the wonderful Vestal Press Collection of Harvey & Marion Roehl in Vestal, NY. Nearly an hour of

never-before-seen footage, including the Q-R-S master vault and star arranger Rudy Martin at work on a new roll. A valuable document of a unique industry!

#ACC-16-VHS (for VHS machines only) \$49.50
#ACC-16-Beta (for Beta machines only) \$49.50

Roll Cabinet

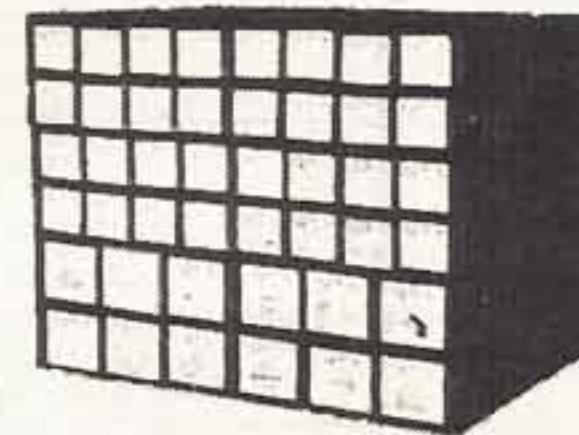

End your roll storage problems with this simulated wood-grain Roll Cabinet, only from Q-R-S! Made of thick, durable corrugated cardboard, it holds 32 small and 12 large rolls and can be shipped at little cost when ordered with

25 rolls or more. It measures 14"H by 19"W by 13"D and can be stacked atop your piano.

Note: Roll Cabinet cannot be shipped empty! You must order at least 25 rolls with each cabinet to comply with postal regulations. Cannot be shipped overseas. #ACC-2 \$9.95

PROFESSIONAL ROLL REPAIR PARTS



As durable as they are, rolls occasionally require repair. Here are the official parts to do the job right.

REPAIR KIT

Here is a handy box of Roll Repair items that is most helpful in cutting your fat XP Rolls in half if your Player Piano can't play them. 2 Small boxes and Spool Assemblies; 1 Large Box and Spool Assembly; 12 Roll Leaders; 12 End Tabs; 12 Rewind Ends; 12 Labels; 12 Rubber Bands and 1 Roll of Scotch Tape. #RRP-1 \$6.95

Small Flanges (Package of 14 pair)	RRP-2 \$4.50
Large Flanges (Package of 5 pair)	RRP-3 \$3.95
End Tabs (Package of 70 tabs)	RRP-4 \$4.95
Cardboard Tubes (Pkg. of 9 tubes)	RRP-5 \$1.95
Small Boxes (Set of 10 boxes)	RRP-6 \$5.95
Large Boxes (Set of 8 boxes)	RRP-7 \$5.75
25 ft. Blank Paper	RRP-8 \$3.95
40 ft. Blank Paper	RRP-9 \$4.95
80 ft. Blank Paper	RRP-10 \$5.95
12 Labels — Pressure sensitive	RRP-11 \$.45

EXCLUSIVE ROLL SETS

Piano Lessons On Rolls: Q-R-S Educator Set



The original "educational software"! This ingenious 6-roll set has started thousands of people on the road to playing the piano by hand! It's a basic keyboard course made up of short, easy-to-understand lessons and clever, instructive duets. Each roll contains printed instructions, large illustrations, and simple exercises. Put on the roll, read the directions, watch the keys demonstrate, and then play them yourself! You can run the roll at any tempo and repeat any part of it as often as you like.

If you have any questions, we've included the acclaimed David Carr Glover book *The Adult Piano Student*. Equally well-suited to children, it is stored in the top compartment of the attractive 6-drawer box which houses the Educator Set.

It's hard work to learn to play. Let the Q-R-S Educator Set make it a little easier — and a lot more fun!

#EDU-1 \$49.95

(Note: The Educator Set cannot be shipped in the Storage Rack or Roll Cabinet listed in this catalog.

NEW!! TV Trivia Set

What a great idea! A treasury of those old TV theme songs we all love and remember! A total of 18 nostalgic treats on six special rolls, packaged in a handsome 6-drawer box:



Beverly Hillbillies

Green Acres, Leave It To Beaver, Mister Ed, Petticoat Junction, Star Trek, Batman, The Andy Griffith Show, All In The Family, The Addams Family, The Real McCoys, Dragnet, Popeye The Sailor Man, The Beverly Hillbillies, Welcome Back Kotter, I Love Lucy, Bonanza, My Three Sons, and The Roy Rogers Show (Happy Trails). PLUS A BONUS!! An illustrated songbook is included! Each TV Trivia Set includes a copy of John Javna's best-selling *TV Theme Song Sing-Along Songbook* — a \$5.95 value! Lyrics, and in many cases music as well, to over 50 shows and commercials. You'll love the photographs, inside facts and trivia quizzes. Available November 15, 1985.

#ACC-13 \$49.95

ROLL STORAGE SPECIALTIES

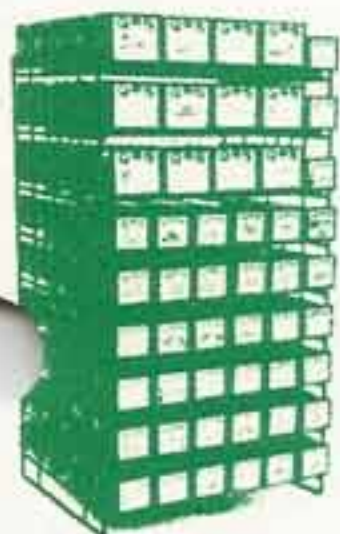

Roll Storage Rack

The sturdiest! Black wrought iron display/storage rack holds 48 small or 30 large rolls. It measures 27½"H x 14½"W x 12"D. Buy two — your local hardware store can furnish inexpensive brackets for stacking or wall mounting if you desire.

Note: The roll rack is shipped via parcel post but postal regulations require that it contain at least 25 rolls.

If you do not order 25 rolls, we must ship by other means, i.e., U.P.S. CANNOT BE SHIPPED OVERSEAS!

#ACC-1 \$43.95

SUGGESTION BALLOT BOX

Complete and mail to Q-R-S, 1026 Niagara Street, Buffalo, N.Y. 14213
LIST SELECTIONS YOU WOULD LIKE ON ROLLS.

NEW

OLD

COUNTRY WESTERN

GOSPEL

CLASSIC

USE EXTRA SHEET IF NECESSARY

SEND ME INFORMATION ABOUT: Please check appropriate boxes ...

Name _____

Address _____

City _____

State _____ Zip _____

AMPICO ROLLS

DUO-ART ROLLS

RECORDO ROLLS

BAND ORGAN, ETC.

Add my name to mailing list

Other _____

Q-R-S MUSIC DISKS for MIDI KEYBOARDS!

If you have an electronic keyboard equipped with MIDI, you can use your home computer to play new Q-R-S MUSIC DISKS!

Inexpensive interfaces for Commodore 64, 128, and Apple IIc are available. With them, you can turn your electronic keyboard into a high tech player piano! Thousands of songs are available on Q-R-S MUSIC DISKS—six to a disk.

For more information, contact:

MICRO-W DISTRIBUTING
1342-B Rt. 23
Butler, NJ 07405
(201) 838-9027

KLEERNOTE TRACKER BAR PUMP

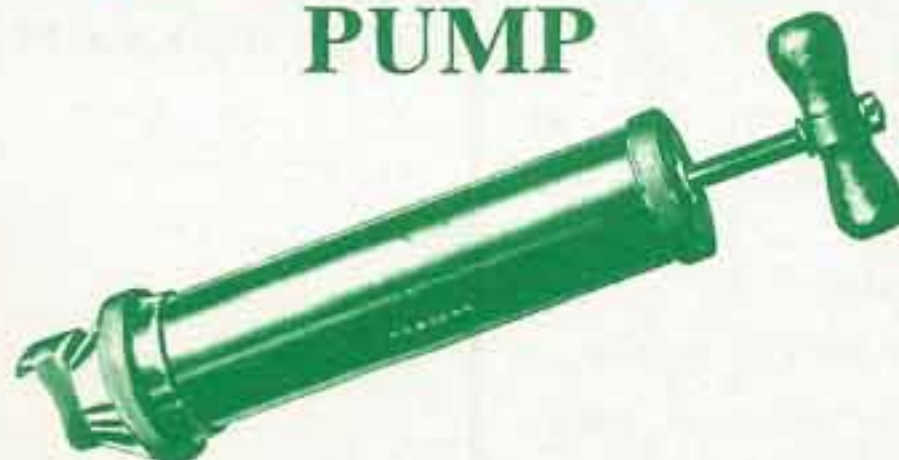

Every player piano owner needs this accessory — the perfect tool for clearing the tracker bar holes of paper particles and dust. Use weekly to avoid weak or silent notes and costly service calls. Note: It may be necessary for you to trim the rubber tip of the pump to insure a tight fit on the tracker bar.

#ACC-6 \$14.00

UNIQUE POSTERS

Unavailable elsewhere! From the Q-R-S archives come these old-time posters, evidence of our long and fascinating history as the originators of the piano roll sound.



Why Buy A Player Piano?

Charming 17" x 22" advertisement which originally appeared in *The Saturday Evening Post* in 1923. Rich, full color in the genuine style of the era.

#POS-3 \$4.50



Put Color In Your Life

This full-color poster reads, "Buy a Player Piano and 100 Q-R-S Rolls — It means happiness as long as you live." It's as true today as when first printed in 1922. 13½" x 20".

#POS-1 \$2.95

Maggie & Jiggs

Specially commissioned by Q-R-S, the stars of the comic strip *Bringing Up Father* sing along to *The Old Piano Roll Blues*! Full color, 8½" x 11".

#POS-2 \$1.95



IMPORTANT

PLEASE ORDER ALL ITEMS
BY ITEM NUMBER.

All prices subject to change without notice.

Guaranteed Merrymaking since 1900: Q·R·S Christmas Rolls

- 1555 ADESTE FIDELIS (OH COME ALL YE FAITHFUL)
- 8455 ALL I WANT FOR CHRISTMAS IS MY TWO FRONT TEETH
- 3316 AWAY IN A MANGER
- 10-340 BLUE CHRISTMAS
- 10-662 CHRISTMAS BELL CAROL (Carol Of The Bells)
- 9775 CHRISTMAS CAROLS
 - 1. O Tannenbaum
 - 2. Jolly Old St. Nicholas
 - 3. We Three Kings Of Orient Are
 - 4. Evening Prayer (When At Night I Go To Sleep)
- 6068 CHRISTMAS HYMNS No. 1
 - 1. Hark! The Herald Angels Sing
 - 2. It Came Upon A Midnight Clear
 - 3. Joy To The World
- 6069 CHRISTMAS HYMNS No. 2
 - 1. O Little Town Of Bethlehem
 - 2. Heavenly Stranger
 - 3. Holy Night
- 2977 CHRISTMAS JINGLES
A 1925 Classic!
- 668 CHRISTMAS MEDLEY
 - 1. Adeste Fidelis
 - 2. Holy, Holy, Holy
 - 3. Come Thou Almighty King
- 9934 CHRISTMAS SONG (CHESTNUTS ROASTING)
- 9639 DECK THE HALL
- 3773 DIVINITY REFLECTIONS No. 2
 - 1. Silent Night
 - 2. Holy, Holy, Holy
 - 3. Adeste Fidelis
- 10-169 DO YOU HEAR WHAT I HEAR?
- 10-821 FELIZ NAVIDAD
- 3319 THE FIRST NOEL
- 10-768 FOR UNTO US A CHILD IS BORN ('Messiah')
- 8681 FROSTY THE SNOWMAN
- 3318 GOD REST YE MERRY GENTLEMEN

- 10-732 THE MOST WONDERFUL TIME OF THE YEAR
- 10-818 MUST BE SANTA
- 3802 O HOLY NIGHT
- 1519 O LITTLE TOWN OF BETHLEHEM
- 10-459 ROCKIN' AROUND THE CHRISTMAS TREE
- 8580 RUDOLPH, THE RED-NOSED REINDEER
- 6044 SANTA CLAUS IS COMING TO TOWN
- 3317 SILENT NIGHT
- 8897 SILVER BELLS
- 9283 SLEIGH RIDE (Leroy Anderson)
- 7221 TOYLAND
- 9989 TWELVE DAYS OF CHRISTMAS
- 10-820 UP ON THE HOUSETOP
- 10-186 WE NEED A LITTLE CHRISTMAS
- 7742 WHITE CHRISTMAS
- 9756 WHITE CHRISTMAS (Modern Arr.)
- 6043 WINTER WONDERLAND
- 244 YULETIDE SONG MEDLEY
 - 1. Silent Night
 - 2. Jingle Bells
 - 3. O Joy To Us
 - 4. Auld Lang Syne

● WORLD'S LONGEST PLAYING CHRISTMAS ROLLS!

- 1553-A SANTA CLAUS TIME
 - 1. Jingle Bells
 - 2. O Christmas Tree
 - 3. Silent Night
 - 4. Grandfather's Clock
 - 5. Chimes
 - 6. Adeste Fidelis
 - 7. Auld Lang Syne
- 10-093-A CHRISTMAS GREETINGS
 - 1. Good King Wencesla
 - 2. Christmas Is Coming
 - 3. Deck The Halls
 - 4. We Wish You A Merry Christmas
 - 5. Toyland
 - 6. Santa Claus Is Coming To Town
 - 7. O Holy Night
 - 8. Here We Come A-Caroling
 - 9. It Came Upon A Midnight Clear
 - 10. Angels We Have Heard On High
 - 11. Silent Night
- 9522-A AROUND THE CHRISTMAS TREE
 - 1. From Heaven I Was Sent To Earth
 - 2. O Come Little Children
 - 3. Oh Faithful Pine
 - 4. Holy Night
 - 5. Come Hither Ye Faithful
 - 6. Tomorrow Will Be Christmas Day
 - 7. O Sanctissimo
 - 8. The Sleighride
- XP-1013-B LAND OF THE CHRISTMAS STAR
(This is a story roll)
 - 1. Silent Night
 - 2. It Came Upon A Midnight Clear
 - 3. Hark! The Herald Angels Sing
 - 4. Evening Prayer
 - 5. Jingle Bells
 - 6. Parade Of The Wooden Soldiers
 - 7. O Come All Ye Faithful
- C-125-A NUTCRACKER SUITE, Part One
- C-126-A NUTCRACKER SUITE, Part Two
- XP-157-B 'T'WAS THE NIGHT BEFORE CHRISTMAS

● OWN AN INSTANT COLLECTOR'S ITEM!

Own an instant collector's item! Every year Q-R-S issues a special limited edition Illustrated Collector's Roll, and every year they go fast! This year's roll is the best ever! Attractive red paper with twinkling white christmas trees makes for a beautiful XMAS-86 roll. This year's edition plays *It's Beginning To Look A Lot Like Christmas; Deck The Hall; Winter Wonderland; Jingle Bell Rock; O Come All Ye Faithful*. ORDER YOURS TODAY!

CHRISTMAS 1986
ILLUSTRATED COLLECTOR'S ROLL
XMAS-86 RETAIL PRICE \$9.00

● LYRIC BOOKLETS

LIFE OF THE CHRISTMAS PARTY
Lyric Booklet

You asked for it! Lyrics to 110 Yuletide favorites and a handy roll index. Order several - and order early!

BKS-13 Price: \$1.98



LIFE OF THE CHRISTMAS PARTY
Companion Songbook

A deluxe, spiral bound companion songbook to the *Life Of The Christmas Party* lyric booklet listed above, complete with music, lyrics, and chords to all 110 songs. An excellent holiday gift!

#BKS-15 Price: \$12.95

● NEW TAPE CASSETTE!

Christmas Player Piano Music, Vol. 1

An absolutely super player piano plays over 15 holiday favorites on this professionally-recorded tape! Take it where the player can't go, or give as a thoughtful gift. Selections are the best, including *White Christmas, Jingle Bells, and The First Noel*.

#ACC-14 Price: \$7.98

● CELEBRATE WITH CELEBRITIES!

Liberace, Ferrante & Teicher, Peter Duchin and JoAnn Castle ought to be on your holiday party guest list! They've personally recorded their finest yuletide tunes on Q-R-S rolls.

- CEL-158-A CHRISTMAS SONG (Chestnuts Roasting), Played by PETER DUCHIN
- CEL-185-A GREENSLEEVES (What Child Is This?), Played by FERRANTE & TEICHER
- CEL-103-A RUDOLPH, THE RED-NOSED REINDEER, Played by JO ANN CASTLE
- CEL-104-A SANTA CLAUS IS COMING TO TOWN, Played by JO ANN CASTLE
- CEL-114-A WHITE CHRISTMAS (Medley), Played by LIBERACE
Includes excerpts from: Jingle Bells, O Come All Ye Faithful, Silent Night.

LATEST CHRISTMAS SMASH HIT! GRANDMA GOT RUN OVER BY A REINDEER 10-843

- 2325 HALLELUJAH CHORUS ('Messiah')
- 10-769 HAPPY HOLIDAY
- 1516 HARK! THE HERALD ANGELS SING
- 10-370 HAVE YOURSELF A MERRY LITTLE CHRISTMAS
- 8449 HERE COMES SANTA CLAUS
- 10-730 A HOLLY JOLLY CHRISTMAS
- 8904 I SAW MOMMY KISSING SANTA CLAUS
- 10-731 I HEARD THE BELLS ON CHRISTMAS DAY
- 7896 I'LL BE HOME FOR CHRISTMAS
- 1517 IT CAME UPON A MIDNIGHT CLEAR
- 8795 IT'S BEGINNING TO LOOK A LOT LIKE CHRISTMAS
- 10-817 JESU, JOY OF MAN'S DESIRING
- 10-101 JINGLE BELL ROCK
- 1798 JINGLE BELLS Played by Frank Milne
- Q-227 JINGLE BELLS
Played by Osborne & Howe, 1922.
- 8447 JINGLE BELLS BOOGIE
- 2477 JOY TO THE WORLD
- 8071 LET IT SNOW
- 10-770 LET THERE BE PEACE ON EARTH
- 9926 LITTLE DRUMMER BOY
- 10-767 MELE KALIKIMAKA
(Hawaiian Christmas Song)
- 10-819 MERRY CHRISTMAS DARLING
- 8578 MERRY CHRISTMAS POLKA

continued next column

SAVE 30% OFF SINGLE ROLL PRICES!

CHRISTMAS PARTY PAK II

Best Seller!

18 YULETIDE FAVORITES
on 6 SPECIAL LONG-PLAY ROLLS
plus 6 LYRIC BOOKLETS
Specially packaged in a 6 drawer box!

- | | |
|-------------------------------|-------------------------------|
| ANGELS WE HAVE HEARD ON HIGH | JINGLE BELLS |
| AWAY IN A MANGER | JOLLY OLD SAINT NICHOLAS |
| DECK THE HALL | JOY TO THE WORLD |
| THE FIRST NOEL | O CHRISTMAS TREE |
| GOD REST YE MERRY GENTLEMEN | O COME ALL YE FAITHFUL |
| HARK! THE HERALD ANGELS SING | O HOLY NIGHT |
| HERE WE COME A-WASSAILING | O LITTLE TOWN OF BETHLEHEM |
| IT CAME UPON A MIDNIGHT CLEAR | SILENT NIGHT |
| | WE THREE KINGS OF ORIENT ARE |
| | WE WISH YOU A MERRY CHRISTMAS |

#ACC-10 Price: \$49.95

Note: Cannot be shipped in the Storage Rack or Roll Cabinet listed in the catalog. No substitutions, please! These 6 rolls are not available separately!

Q·R·S

MUSIC ROLLS
INCORPORATED

1026 NIAGARA STREET
BUFFALO, N.Y. 14213

MEEI[®]

CLOUDMAKER

FOG, THE STUFF OF CLOUDS



MEE INDUSTRIES INC.

The MEE II CloudMaker® is the first quality, low cost cloud fog system designed for small areas from 500 to 15,000 square feet. Multiple systems may be used for larger areas.

It is the simplest to operate, most automatic fog system available today.

The MEE II CloudMaker is equivalent in quality to the large, custom installations made by Mee Industries. The MEE II incorporates state-of-the-art technology in cloud fog making for microclimate control.

The MEE II CloudMaker provides for excellent evaporative cooling, humidifying, and freeze protection, as well as being a breakthrough for propagation and tissue cultures and for pesticide and foliar feed applications.

The fiberglass control module is a self-contained unit. It is very easy to operate. Everything is in this one unit. All the necessary water treatments, filters, even a simple way to add chemicals if desired, are included. This makes the system the most versatile one available.

The MEE II can be operated automatically on timers, or controlled remotely by using its humidistat/thermostat sensors located within the greenhouse. Its electronic sensors and controls maintain the chosen optimum microclimate in the greenhouse.

The system can be used to maintain ideal growing humidity when heaters are operating or can be used to provide a zero transpiration, test-tube environment for propagation. All the grower has to do is dial his desired humidity.

The MEE II can also be used for evaporative cooling much the same way as pads have been used in the past. The difference is that fog is twice as effective as pads when used for cooling.

The MEE II is very easy to install. All one has to do is connect its water supply line, its copper fog lines, and plug it in.

The MEE II has been engineered for ease of installation with no need for special tools or equipment. Detailed installation and operating instruction manuals, including engineering drawings and schematics, are provided to assure quick and simple installation. Trained Mee Industries technicians and installation personnel are also available to provide on-site assistance if requested.

The MEE II has been specifically designed to give the grower the freedom of custom design, as well as the advanced technical engineering to make the system a compact, self-contained, self-monitoring unit.

The MEE II is cost competitive to any system on the market yet is far superior with its versatility.

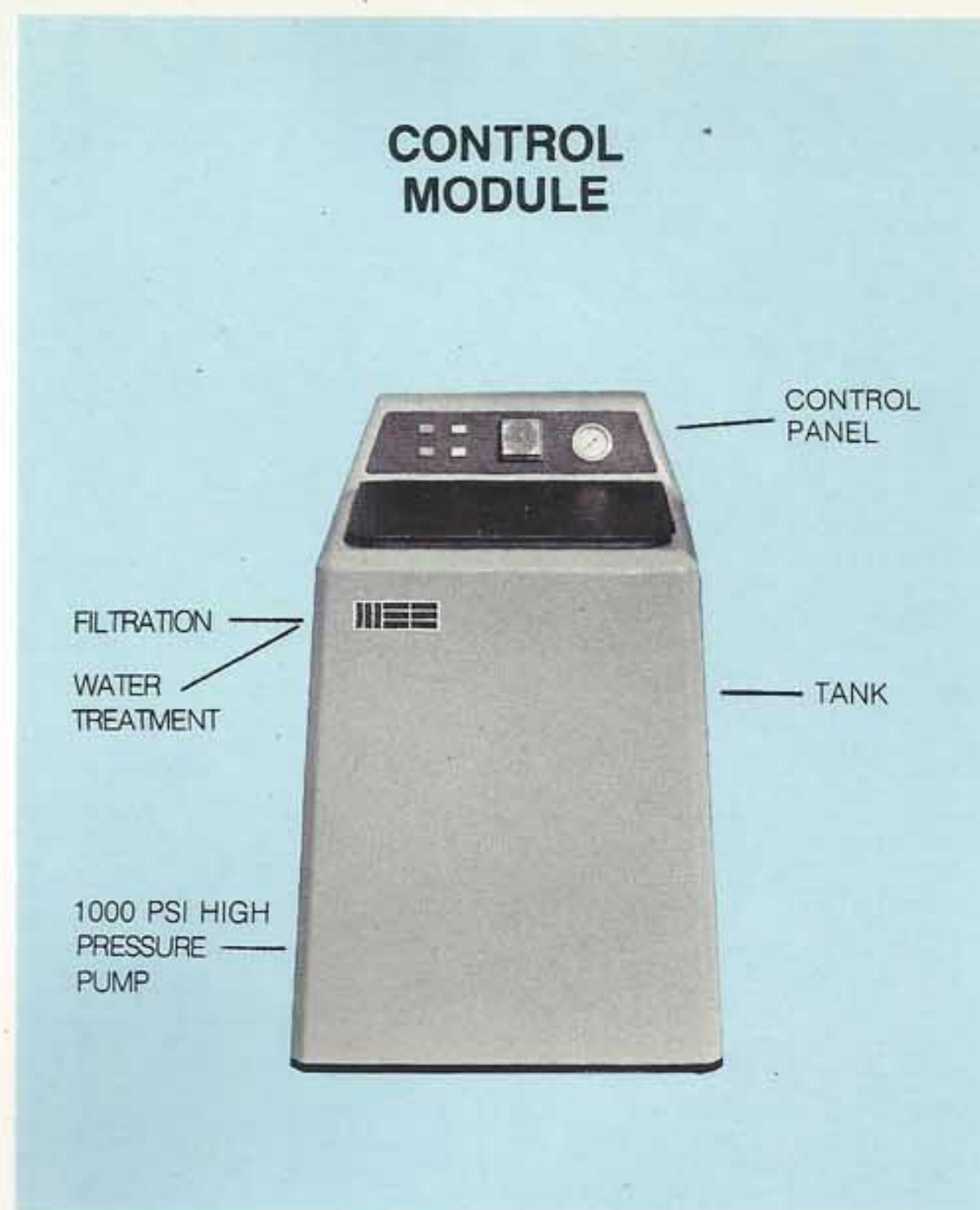

Self-contained MEE II Fiberglass Control Module

HOW THE MEE II CLOUD FOG SYSTEM™ WORKS

The Mee II CloudMaker® System creates real cloud fog droplets so tiny they float in air. Smaller than micromist, the droplets measure about 10 microns in diameter or approximately one-tenth the diameter of a human hair. The standard scientific definition of fog is a water droplet smaller than 40 microns.

To produce these tiny fog droplets, the MEE II uses a patented MEE nozzle to atomize the water. High pressure pumps force 1000 psi water through a small orifice in the nozzle to make a narrow water jet. This jet impacts against a specially designed pin and is broken up into ultra-fine water droplets.

The very tiny size of true fog droplets, although not easily discernible, is important because of their ability to float in the air for long periods of time, as well as evaporate very quickly in hot weather. Droplets larger than 40 microns (micromist and mist) will fall quickly to the ground before evaporating, wetting plants and growing medium, and are much less efficient when used for cooling.

PATENTED MEE FOG NOZZLE

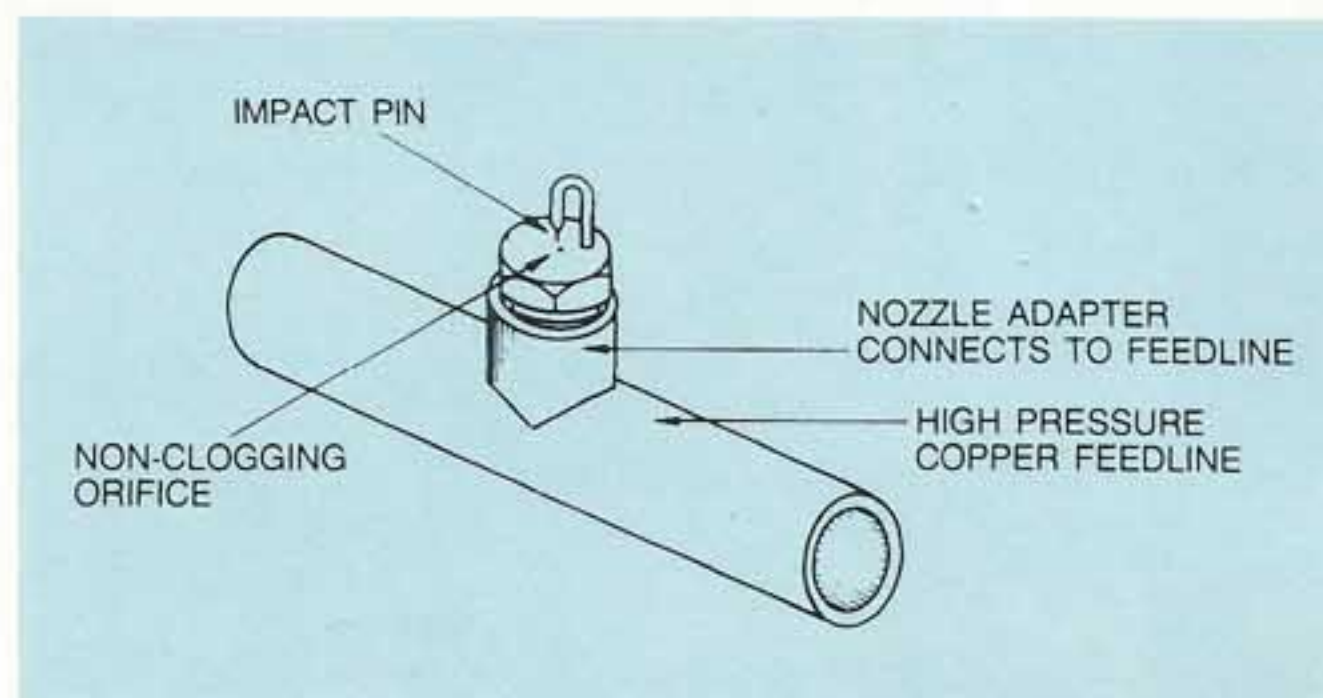

THE MANY USES OF THE MEE II CLOUD FOG SYSTEM™

Evaporative Cooling

Tiny Fog droplets totally evaporate, become cold and absorb heat. This cools the greenhouse uniformly and eliminates temperature gradients. *Users of the MEE system report more turns and better quality; 35% increase in production and a 80% savings on energy costs. Cools two times better than pads. Plants utilize higher light levels without tip burn and stretching is reduced. Botritis and powdery mildew greatly reduced. Surprisingly low water usage. Plants and workers stay dry.*



Cold, dry fog evenly cools the greenhouse 20° to 35° below outside temperatures.

Propagation/Germination/Tissue Culture

Tiny droplets of fog saturate the air and assure zero transpiration. Real cloud fog humidifies without overwetting, so the growing medium stays moist and fluffy, allowing oxygen to get to the roots. *Users of the MEE system report more turns with virtually 100% yields. A test-tube environment with no overwetting. Superior root systems. Faster rooting especially with difficult to root species. Large cuttings can be rooted without leaf loss. Multilevel space utilization and higher density planting. Seed flats germinate fully without washout. Tissue culture plantlets don't even know they have left the test tube. Irrigation and labor costs are greatly reduced. Workers stay dry.*



Fog saturated air, without overwetting, enables direct stick propagation of large cuttings.

Humidity Control

Tiny fog droplets surround the plants relieving heat stress and tip burn. With optimum humidity stomata stay open even at high temperatures so that photosynthesis continues and production increases. *Users of the MEE fog system report faster crop maturity. A greater number and better quality plants were produced. No overwetting of plants or medium. Large field grown plants acclimated to containers without leaf loss. Controlled many pests and common plant diseases.*

Supplemental Heating

Tiny fog droplets saturate the air, trapping and reflecting the heat given off by the heaters. The fog distributes the heat evenly, warming both plants and medium, and eliminating hot and cold spots throughout the greenhouse. *Users of the MEE fog system report that thermostats can be set at least 10° lower with energy savings from 15% to 50%.*



Fog floating in the air blankets plants, retaining heat, as the sun warms both plants and growing medium.

Natural Bottom Heating

Humid, fog laden air prevents evaporative cooling of the growing medium. Sunlight heats the medium to temperatures warmer than the air and fog prevents heat loss. *Users of the MEE fog system report that with fog the growing medium temperature stayed 10° warmer than the air.*

Foliar Feeding

Tiny fog droplets carry an automatically measured amount of chemicals to plants. Because these real fog droplets float in the air instead of falling, they migrate deep into the foliage, covering both the top and bottom of the leaves uniformly. *Users of the MEE fog system report reduced labor and material costs.*

Freeze Protection

Tiny fog droplets blanket the crop and saturate the air, trapping and reflecting radiant heat. Another plant warming mechanism in fog is due to "latent heat", or the heat energy given off when water changes from vapor to liquid, or dew. In fog, leaves and blossoms are warmed by this powerful heating mechanism. If this water then freezes still more heat is released as "latent heat" of fusion. In fog, this latent heat protects the plant from damage even in severe conditions.

Although most greenhouses have heaters, fog has protected entire crops when power was lost. Freeze protection is most widely used outdoors, over large areas. *Users of the MEE fog system have reported saving a greenhouse full of tropical plants when their boilers went out for three days, with snow on the ground. More effective protection and lower overall cost than other systems of freeze protection was reported for outdoor use.*

Other Applications

Aeroponics is a special growing system for plants where their roots are suspended in air. *Outdoor Air Conditioning and Landscape Design with fog is being used to cool and humidify outside living spaces. Special Effects with fog have been used in theaters, amusement parks and museums.*

The MEE family of microclimate control systems have been invented and patented by Thomas R. Mee, President and Chairman of the Board of Mee Industries. Mr. Mee, a former Cornell University scientist has an extensive background in cloud physics and weather modification.

At Cornell's Aeronautical Research Lab Mr. Mee did pioneering work in the early understanding of cloud physics in the formation of ice crystals and cloud and fog water droplets.

After leaving Cornell, Mee was the Director of Advanced Development for Meteorology Research, Inc. Mee worked on numerous projects that were the cutting edge of understanding cloud physics and weather modification.



Diane and Tom Mee, with the MEE II Cloudmaker Fiberglass Control Module, standing in front of Mee Industries experimental greenhouses.

Mee Industries was founded in 1969 by Tom Mee who has done consulting research for numerous companies on a global basis. Clients have included numerous branches of the United States Government: NASA, Department of the Interior, Bureau of Reclamation, and various departments within the Department of Defense including the Army, Navy, and Air Force. Mee Industries has done an equal amount of work for large corporations: TRW, Hughes, Northrup, and Weyerhaeuser as well as many private research laboratories such as the National Hurricane Lab, and Battelle Northwest Laboratories.

Tom Mee is the inventor of the first successful man-made fog system and has more than 1,000 fog systems installed worldwide. The Mee systems are covered by three existing patents, and are currently the only patented systems in the marketplace.

Mee Industries also manufactures the finest scientific instruments available for cloud physics use.

Mee Industries equipment includes: automatic ice nucleus counters, cloud condensation nucleus counters, cloud ice particle counters, electronic psychrometers, and related scientific equipment which dominate the world's market in cloud physics.

MEE II CloudMaker Fog System Includes

- Patented MEE Fog Nozzles
- Easy to Operate Control Panel
 - Humidistat/Thermostat control for total automation
 - Automatic 24-hour controller clock
 - Automatic repeat cycle timer
 - Lighted push button indicator switches
 - High pressure gauge
 - Change filter indicator
 - Timer/Remote selector
 - On/Off power button

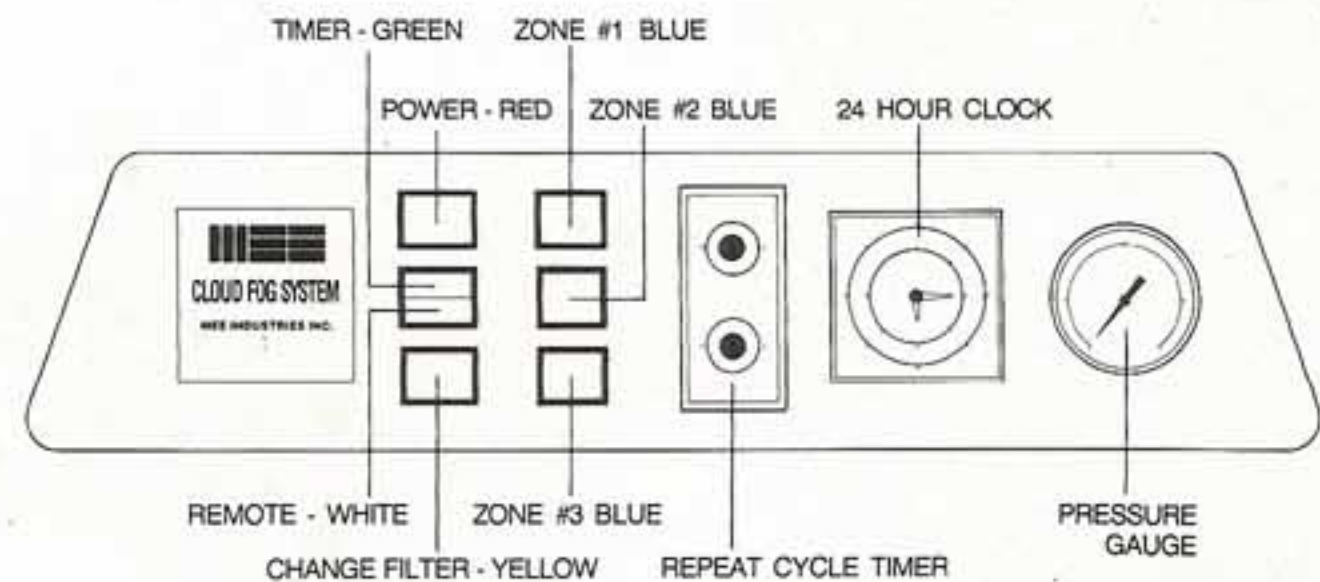

- Remote Control Capabilities
- Self-contained Fiberglass Control Module
 - Ultra filtration to five microns
 - High pressure pump and motor (acoustically isolated)
 - Mixing tank
 - Float switch
 - Automatic water treatment dispenser
 - Automatic filling device
 - Automatic pressure regulator
 - Automatic overflow protection
 - Adjustable feet for leveling
 - Electric power either 110, 220 or 440 volt, single or three phase, 50/60 Hz, 1½ H.P. to 5 H.P.
- All Copper Feedline and Fittings
- Installation and Operating Manuals
- 1000 psi High Pressure Fog
- Mee Fog is so Dry, System Can Be Run 24 Hrs. a Day
- Low Water, Low Energy Usage
- Cost Competitive to Any System on the Market
- Unconditional Guarantee on Mechanical Components for One Year

Call for your free quote today **800-REAL-FOG** in California call 800-824-4784

The Cloud Fog System by MEE



MEE INDUSTRIES INC.

1629 S. Del Mar Ave. • San Gabriel, CA 91776 • (818)-288-4650 • TELEX: 673392
508 West Orange Blossom Trail • Apopka, FL 32703 • (305) 886-3686

Patent Numbers: 3,778,542, 3,894,691, 4,039,144

ANALYSIS OF NEW ATTRACTION POTENTIAL

Trike Character

STRATEGY	<ul style="list-style-type: none">• Improves the adult experience.• Maintains or improves the child experience.• Does not diminish the restaurant perception.• Offers new or novel form of entertainment.	<p><i>Yes</i></p> <p><i>Yes</i></p> <p><i>Yes</i></p>
★ ★ ★ ★ ★ ★ ★ ★ ★ ★ NEW ENTERTAINMENT ATTRACTION ★ ★ ★ ★ ★ ★ ★ ★ ★ ★	<ul style="list-style-type: none">• Are development costs required? How long? - How much?• Can it be cost effectively adapted to locations?• What is the time frame for field testing?• What is the time frame for rollout?• Are special installation skills required?• What are anticipated maintenance costs?• What are software support costs?• What is projected R.O.I. ?• What will its' life be after 100% R.O.I.?	<p><i>No</i></p> <p><i>Some</i></p> <p><i>No</i></p> <p><i>Batteries</i></p> <p><i>None</i></p>
TIME & COST FACTORS		

Waimo

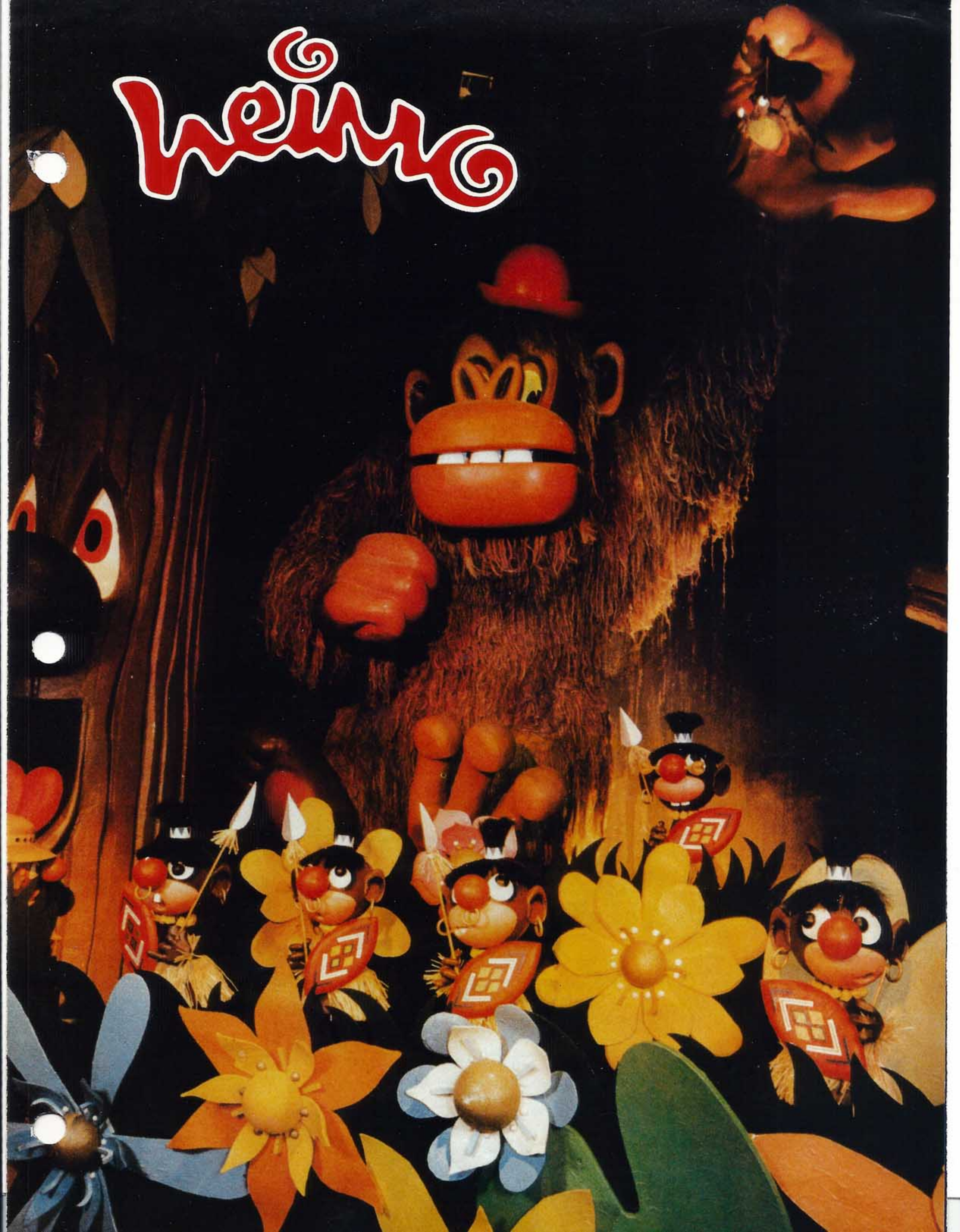



Heinz Mordelt GmbH & Co. KG · Jagsthausen · West Germany

Anhand dieser Broschüre geben wir Ihnen einen Überblick unserer Dekorationsfiguren und Themenschauen, mit oder ohne Kulisse, sowie unserer programmgesteuerten Figuren, einschließlich Ton, Beleuchtung und Bewegung.

Unser Angebot ist individuell und läßt bezüglich der Ausstattung und des Designs keine Wünsche offen.

Wir produzieren Themenschauen, Parkattraktionen, sowie Dekorationen für Kaufhäuser und Shopping-Center nach Ihren Ideen.

Nutzen Sie daher unsere langjährigen Erfahrungen, die Ihnen Produkte nach neuestem Stand der Technik und Design garantieren.

Sollten Sie detaillierte Informationen benötigen, so sind wir gerne bereit, Sie ausführlich zu beraten.

This brochure will give you an overview of our production capabilities for large animated presentations with or without decorations, sound, lighting and computer programming.

The major portion of our production is custom finished to the individual needs and requirements of our customers.

We are actively involved in the design and development of new attractions for amusement parks, department stores and shopping centers through out the world.

Take advantage of our many years of experience and our ability to produce in the newest state of the art currently available on the market.

Should you require more detailed information or advice, we would be more than happy to serve you.

„Fisch der Fische“ Innenausstattung mit 20 Aquarien, zum Durchlaufen. Fisch Polyester, Länge über alles 20 m, Breite 5 m, Höhe 6,5 m. Augen, Schwanz und Seitenflossen sind beweglich.

„Fish of all Fishes“ walk through attraction decorated internally with 20 aquariums, is constructed with fiber-glass and is 65'5" long, 16'5" wide and 21' high. The eyes, tail and side fins are mechanically animated.



Ausschnitte von Dekorationen mit beweglichen Figuren in Shopping-Centern, käuf- oder leihweise lieferbar. Themen wie z. B.: „Engelwerkstatt“ (2), „Wichtelhausen“ (3), „Arche Noah“ (4), „Märchenschauen“ (5), „Pinocchio“ (11-15), „prähistorische Schau“ (16-17), „Gulliver“ (21-24).

Various displays for sale or lease to shopping centers or department stores: „Great Cloud of Angels“ (2), „Dwarf Mountain“ (3), „Noah's Ark“ (4), „Children's Fairy Tales“ (5). The scenes pictured on the adjoining pages are also part of our standard program: „Pinocchio“ (11-15), „Prehistoric World“ (16-17), „Gulliver's Travels“ (21-24).

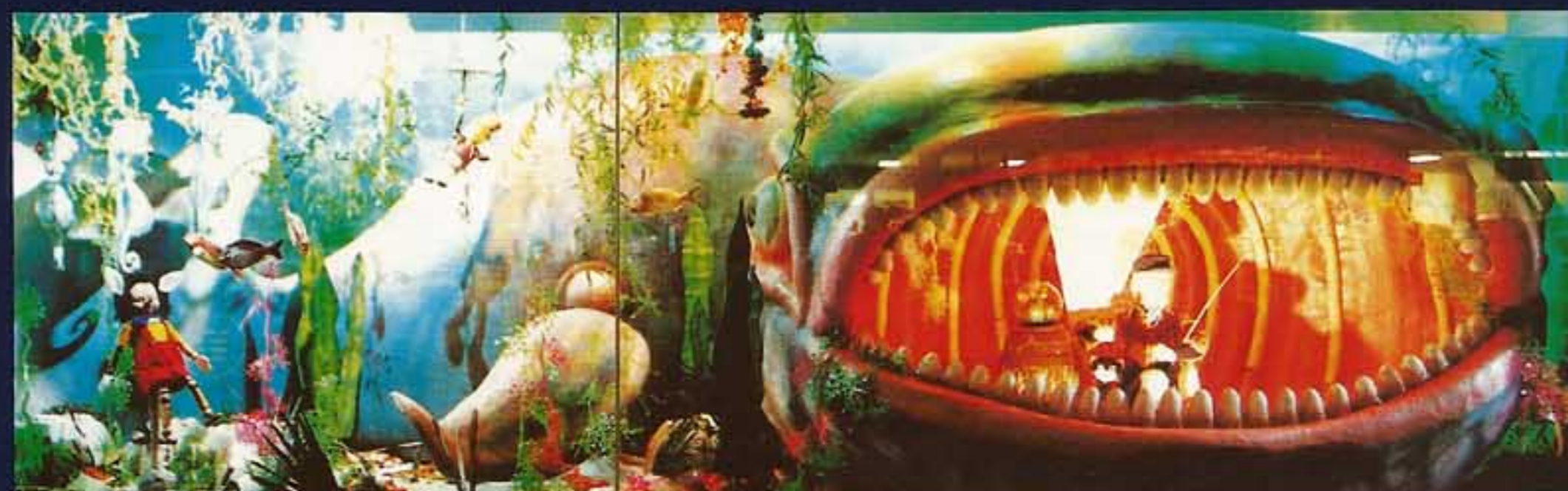
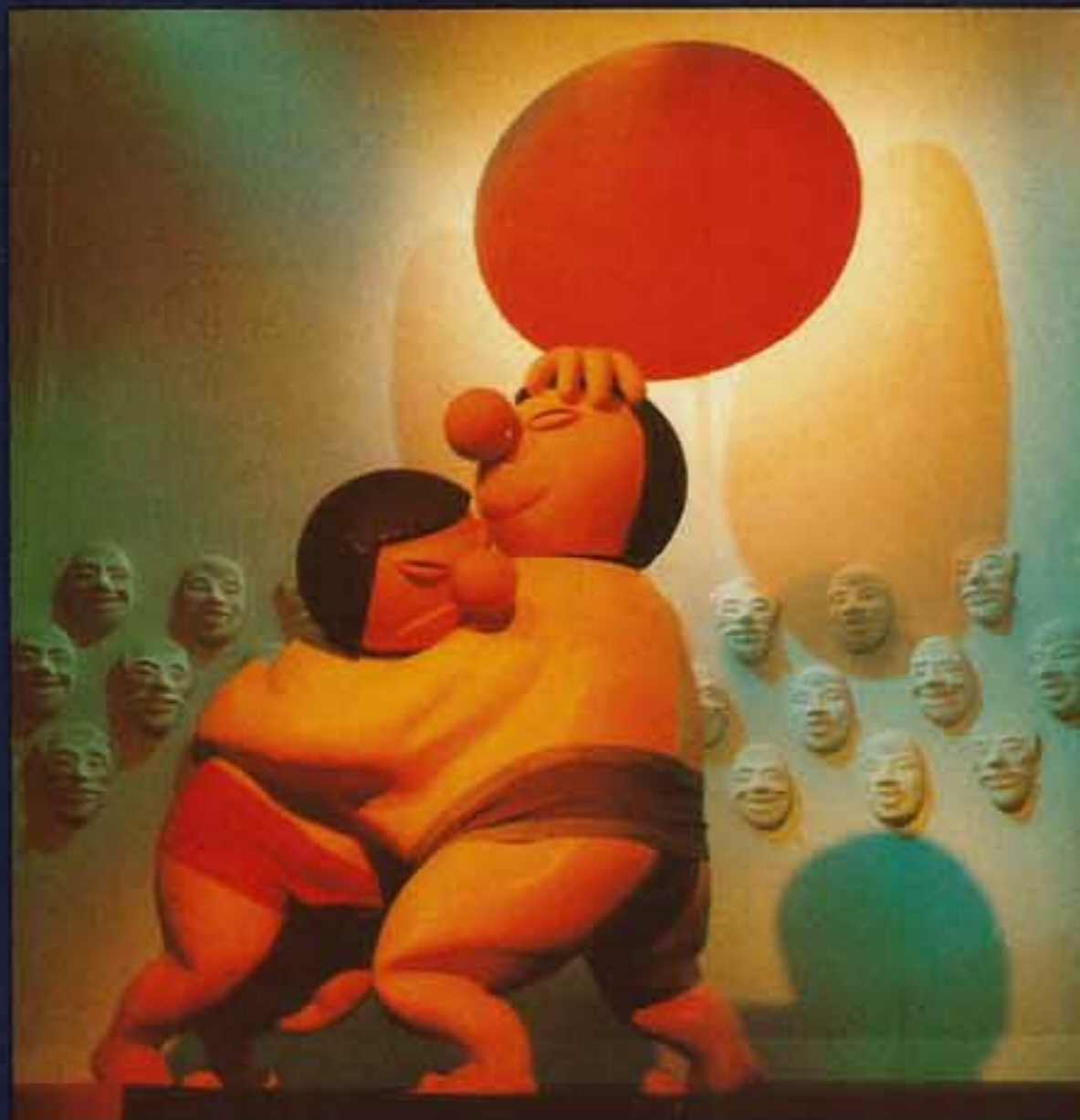

„Pinocchio-Ausstellung“ in 8 Szenen, Kaufhaus Fenwick in GB Newcastle. (11-15) 27 m lang, Höhe 2,80 m. Figur „Gepetto“, lebensgroß, 180 cm hoch, „Pinocchio und seine Freunde“ 80 - 100 cm hoch, Walfischlänge 8 m.

The Story of „Pinocchio“, presented in 8 scenes for Fenwick's department store, Newcastle. Great Britain. (11-15) 88'6" long, 9'3" high. The whale is 26'3" long and „Pinocchio“ is 3' Ft. high. The fairy and „Gepetto“ are life size.



„Reise um die Welt“ (18-20) „Edenlandia“, Neapel, Italien, mit internationaler Dekoration. Figuren 80 x 300 cm hoch. „Gulliver's Reisen“ (21-24) Fensterfront 27 m. 1 Gulliver, Länge 12 m, Höhe 2,80 m, 47 Lilliputs, 80 cm hoch.

„Small World“ (18-20) dark ride with figures from 2'6" to 10' high for „Edenlandia“, Naples, Italy. „Gulliver's Travels“ (21-24). The theme show in one scene which has a total of 47 lilliputans and is 88'6" long, 9' high.

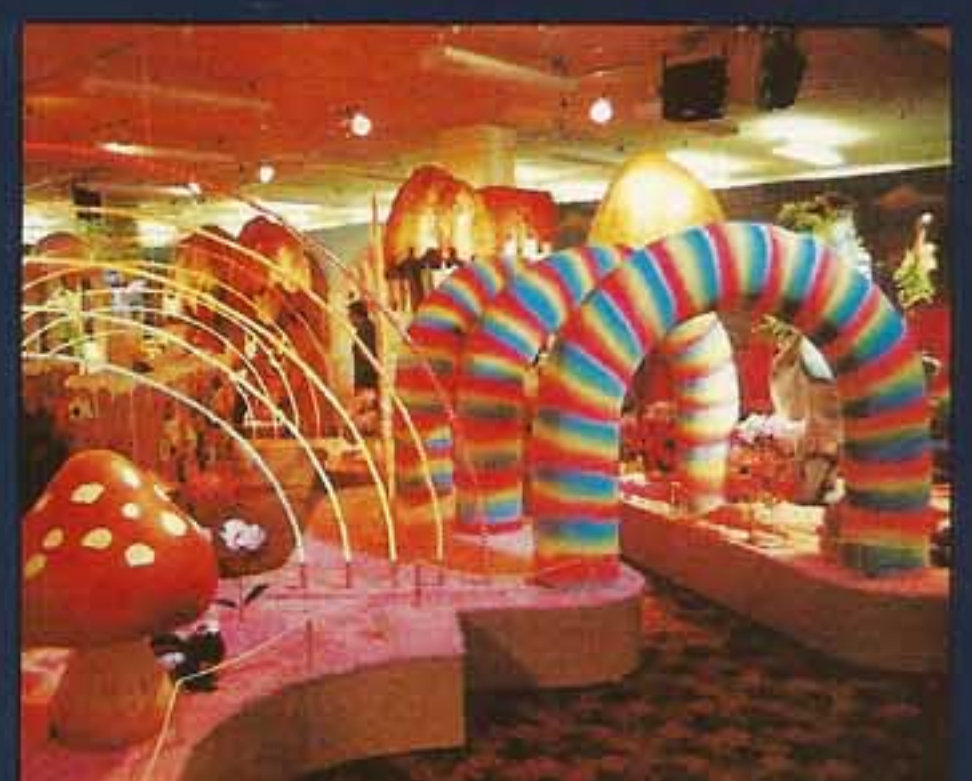
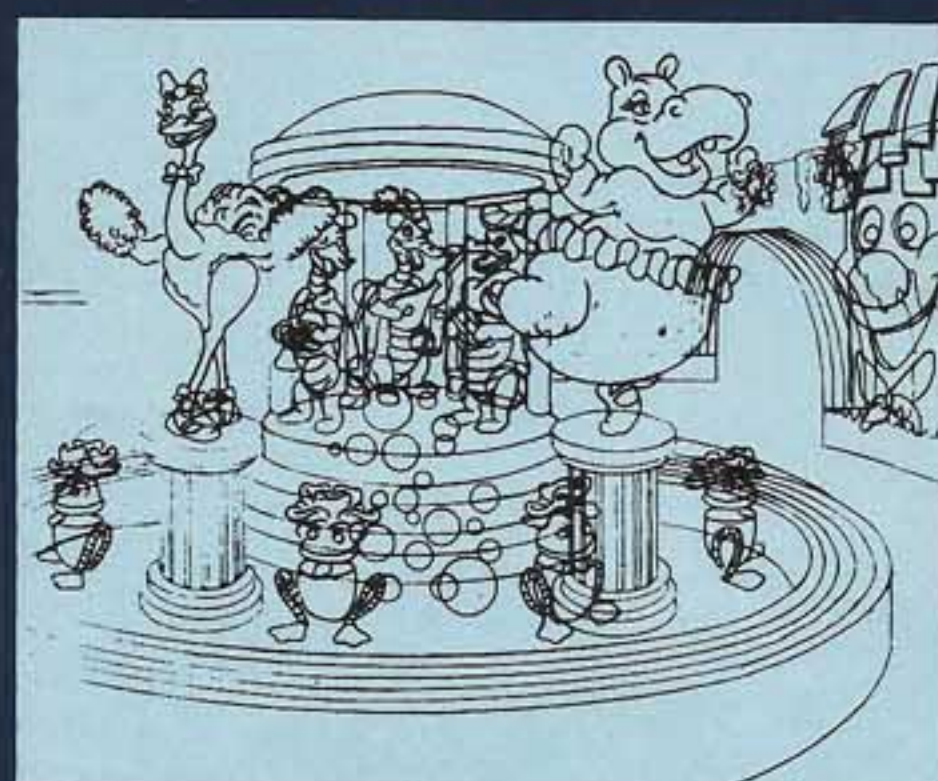
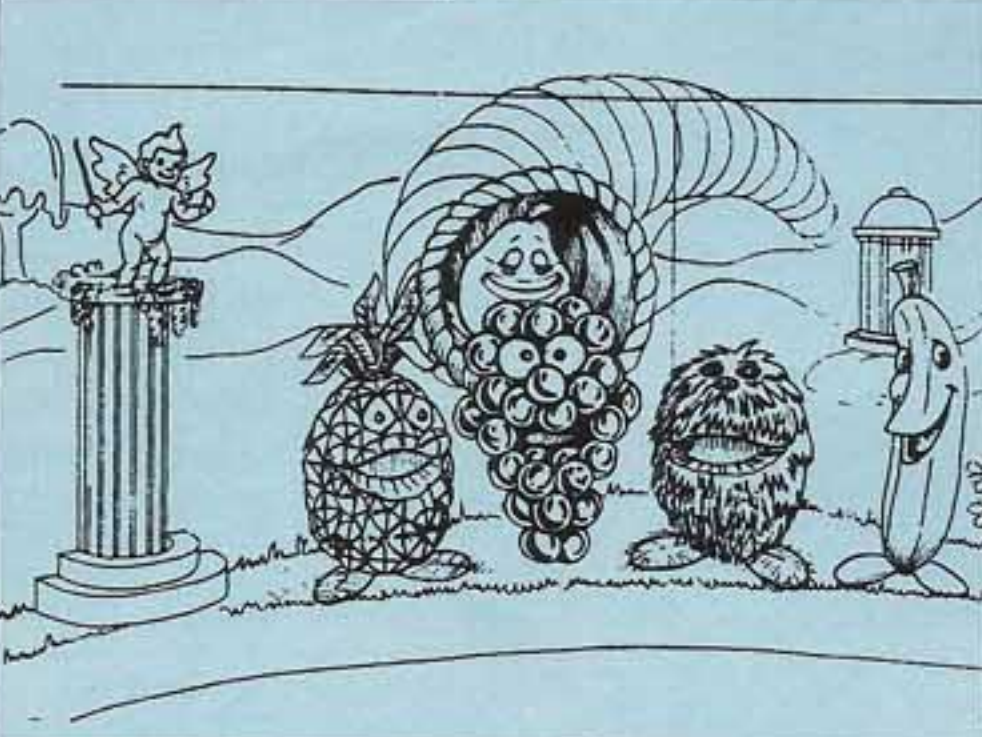
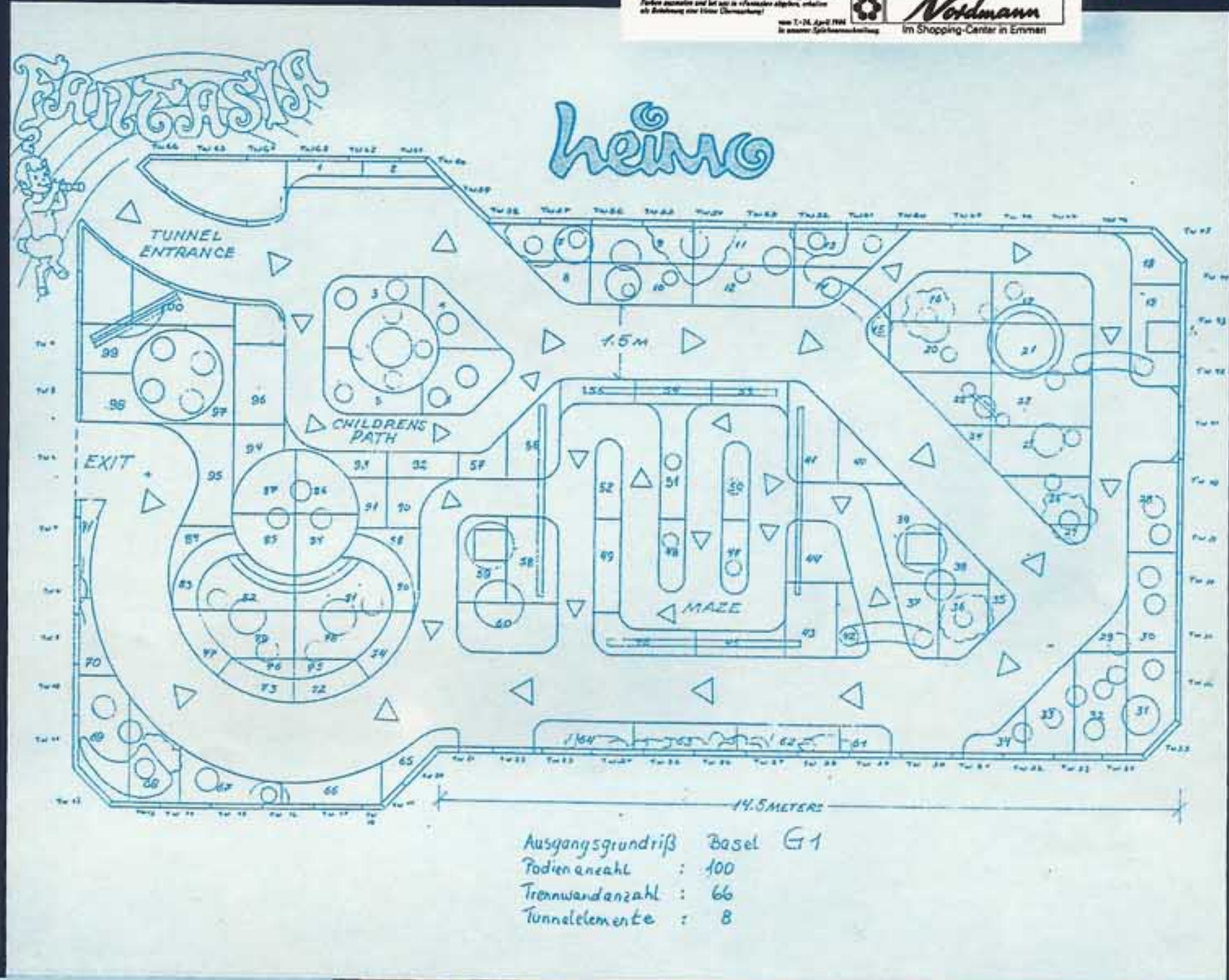
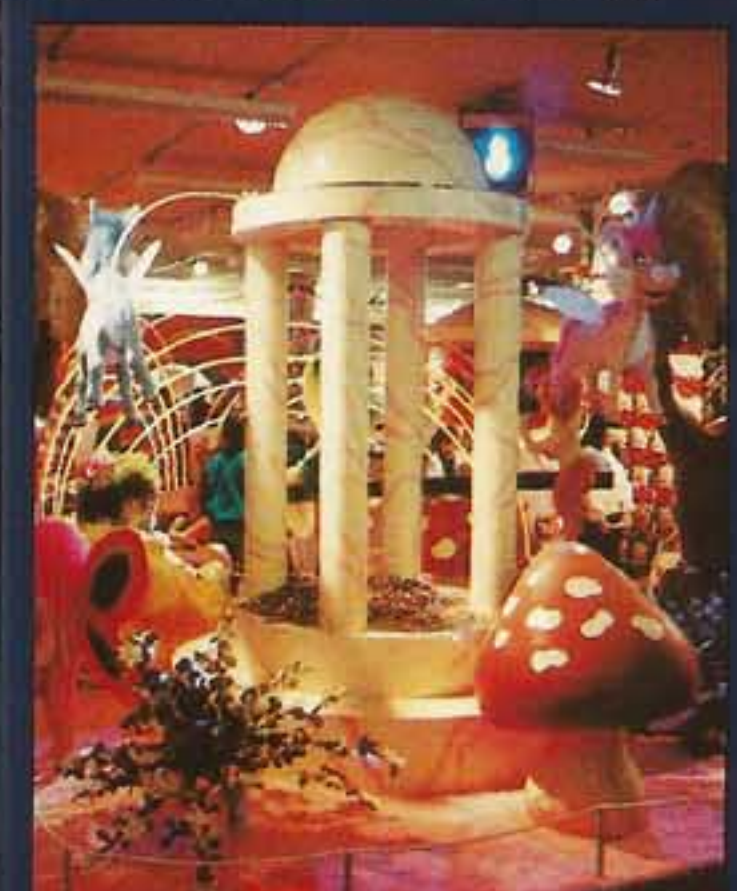
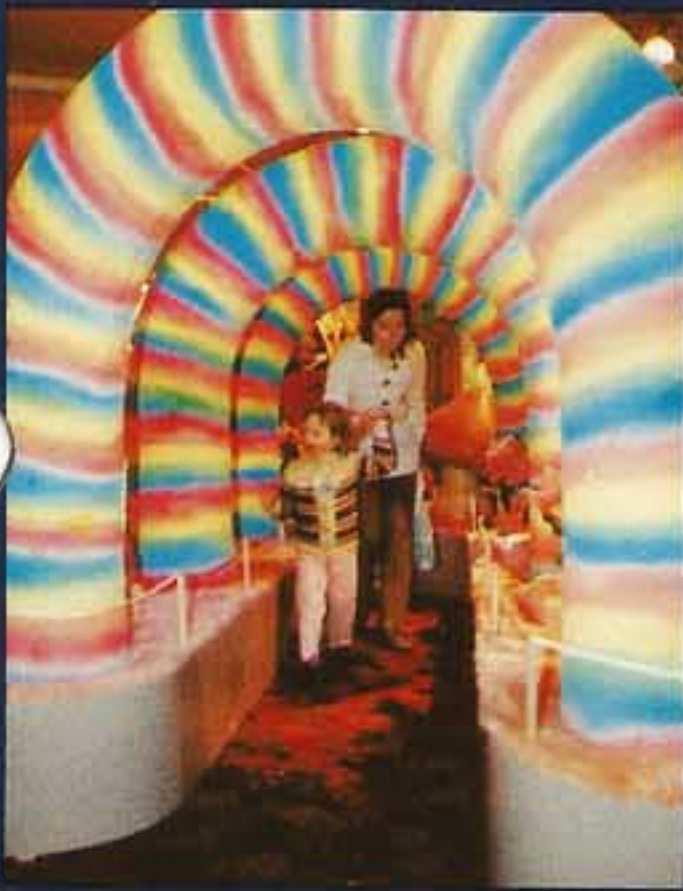

ANALYSIS OF NEW ATTRACTION POTENTIAL

WALK THRU

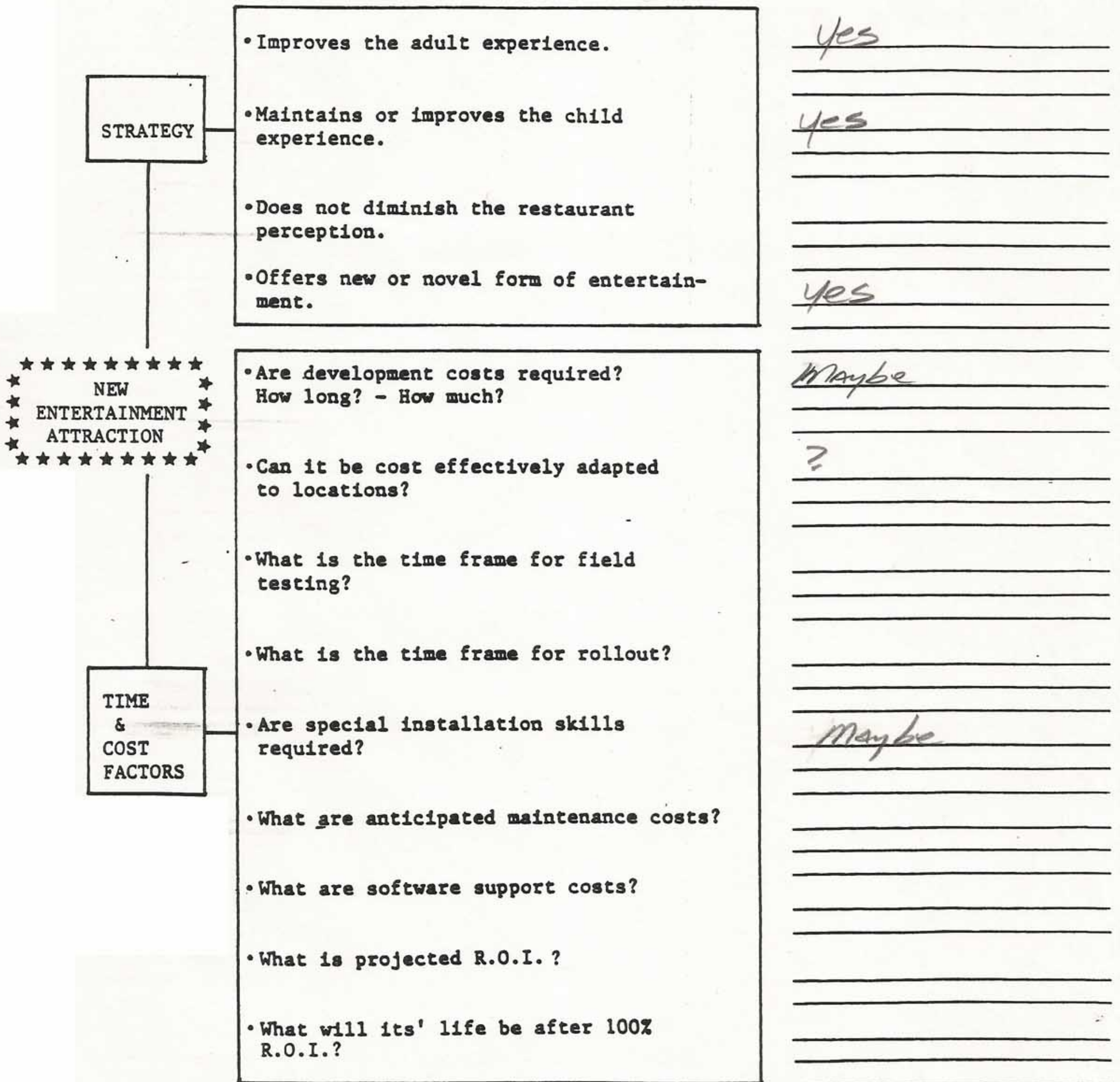



Jr. Round-A-Bouts Specifications (\$745.00 EA.)

Body

- Heavyweight Fiberglass Construction
- Textured, Non-Slip Footing
- Separate Battery Compartment
- Marine Vinyl Covered Seat
- 34½" O.D. x 22½" Height
- Weight 20 lbs.
- Deluxe Metalflake Finish
- Standard Colors Red Blue
Orange Yellow Green Almond

Tube

- Roto-Molded PVC Construction
- Uniform 1/8" Wall Thickness
- 42" O.D. x 18" I.D.
- Weight 16 lbs.
- Recessed Valve Stem
- Repairable w/Optional Repair Kit
- Standard Colors Red Blue
Orange Yellow Green

Electric Motor

- Permanent Magnet Gearmotor
- 12 Volt D.C. Operation
- 1/10 H.P. Input Horsepower
- 10 Amp Normal Operating Consumption
- Electrical Circuit Breaker Protection
- Ball Bearing Gear Unit Construction
- Totally Enclosed Construction
- Ball Bearing Motor Construction

Tires & Drive Type

- 6 x 2 Semi-Pneumatic (Rear)
- 6 x 2 U.H.M.W. (Front)
- 5 x 2 Phenolic Casters (Outrigger)
- Single Wheel Drive
- 3/4" Drive Axle
- Heavy-Duty Flange Bearings
- Chain Drive
- Torque Limiter Protection

Total Weight 135 lbs. Overall Height 30" Overall Dia. 42"

1-3/4 M.P.H. Safe Operating Speed

NOTE: Battery Not Included In Either Price or Weight

Kid-Mobile Specifications (\$795.00 EA.)

Body

- Heavyweight Fiberglass Construction
- Textured, Non-Slip Footing
- Separate Battery Compartment
- Large Marine Vinyl Covered Seat
- 30" Width x 48" Length
- Weight 25 lbs.
- Brilliant Metalflake Finish
- Standard Colors Red
Green Blue Gold

Electric Motor

- Permanent Magnet Gearmotor
- 12 Volt D.C. Operation
- 1/10 H.P. Input Horsepower
- 10 Amp Normal Operating Consumption
- Electrical Circuit Breaker Protection
- Ball Bearing Gear Unit Construction
- Totally Enclosed Construction
- Ball Bearing Motor Construction

Tires & Drive Type

- 6 x 2 Semi-Pneumatic (Rear)
- 6 x 2 U.H.M.W. (Front)
- 5 x 2 Phenolic Casters (Outrigger)
- Single Wheel Drive
- 3/4" Drive Axle
- Heavy-Duty Flange Bearings
- Chain Drive
- Torque Limiter Protection

Total Weight 140 lbs. Overall Height 28" Overall Width 30½"

1-3/4 M.P.H. Safe Operating Speed

NOTE: Battery Not Included In Either Price or Weight

MIDDLEBUG BY

MILMA fab



MIDDLEBUG BY

mllm A fab

The 'MIDDLEBUG' is a robustly constructed pedal powered attraction for use in leisure parks, large or small. A number of these fun machines used on a simple track by virtue of the unorthodox steering, provide an attractive challenge for 8 year olds to adults at very low cost.

The 'MIDDLEBUG' should be used on a tarmac surface which can be laid out in many ways, from a simple oval racetrack to an intricate obstacle course, which will provide the greatest fun and interest.

The 'MIDDLEBUG' is engineered to provide long service under the most arduous conditions. The crank is supported on ball races and the wheels are on roller bearings. The chassis is constructed from steel tube and epoxy powder coated. The seat is a strong G.R.P. moulding fixed to the chassis by four bolts.

There is also available a 'MINI MIDDLEBUG' designed for use by younger children. The 'MINI MIDDLEBUG' can be very effectively used indoors on a small obstacle course.

We reserve the right to change specifications without notice.

Specification

Chassis:	Tubular steel
Wheels:	16" diameter pneumatic tyres on red polypropylene centres
Seat:	G.R.P. moulding in red
Bearing:	Ball and roller races
Finish:	Epoxy powder coated in golden yellow

mllm A fab

Stocks Brow · Kirby Misperton · Near Malton
North Yorkshire · England · Telephone: (065386) 694

Printed by Maxiprint, York

swing ride

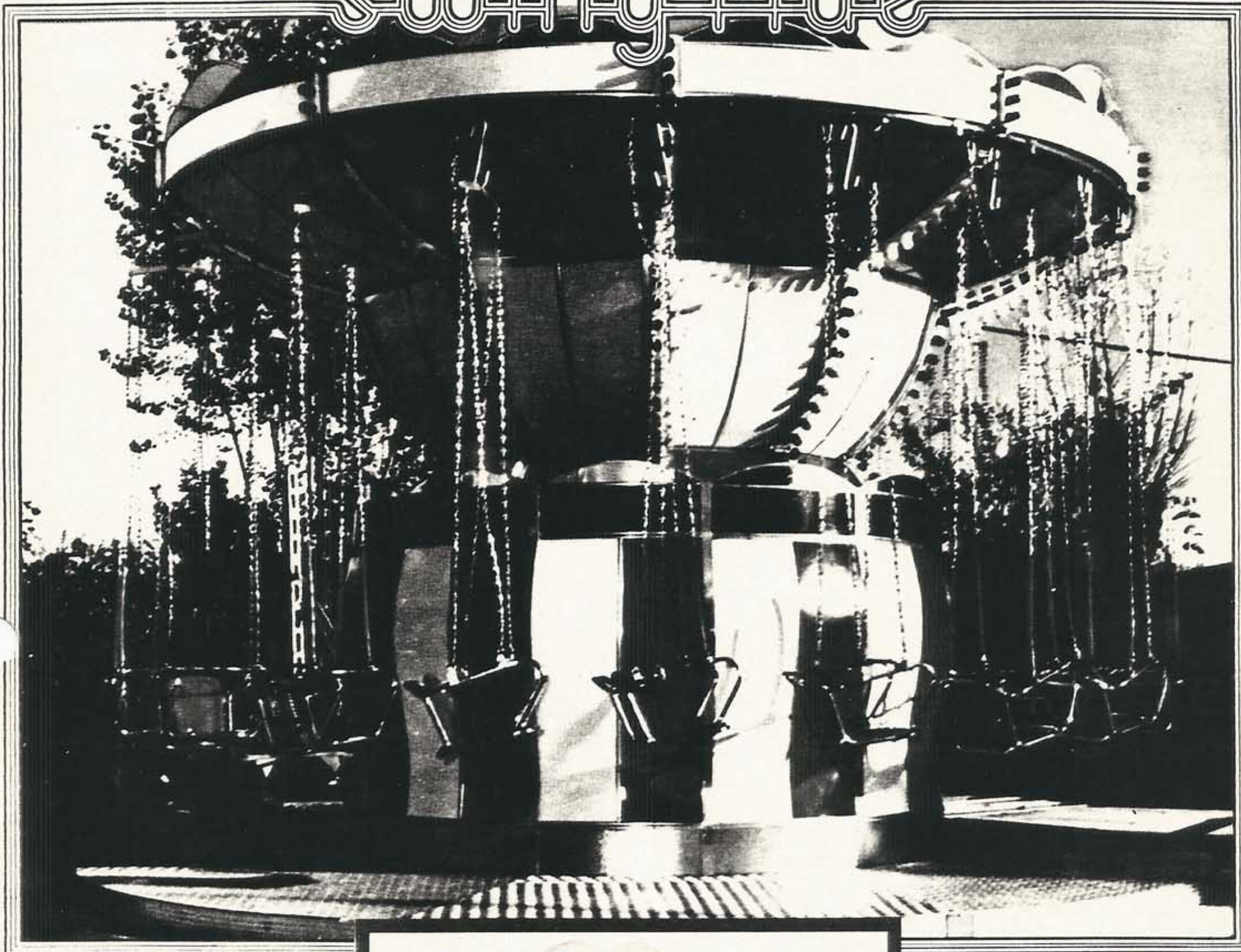

All specifications subject to change without notice caratti&poletto/vicenza

petites swing



THE SWING RIDE AND MINI SWING RIDE:
 A DELIGHTFUL RIDE WITH THE DOUBLE MOTION OF SWINGING AROUND WHILE THE NATURAL PULL OF THE RIDE'S ACTION MOVES EACH RIDER OUT, UP AND DOWN. FLASHING LIGHTS AND A GAILY COLORED CANOPY AND THE KIDS' EXCITEMENT.
 TOTAL CAPACITY: 20 AND 6 SEATS.

GENERAL SPECIFICATIONS:
SWING 20: DIAMETER: 15 Ft. in action 21 Ft. HEIGHT: 10 Ft. MOTIVE POWER: SINGLE PHASE 110 V. 60 HZ 3 KW. WEIGHT: 2500 LBS.
SWING 6: DIAMETER: 12 Ft. in action 15 Ft. HEIGHT: 9 Ft. 8 inc. MOTIVE POWER: SINGLE PHASE 110 V. 60 HZ 3 KW. WEIGHT: 980 LBS.

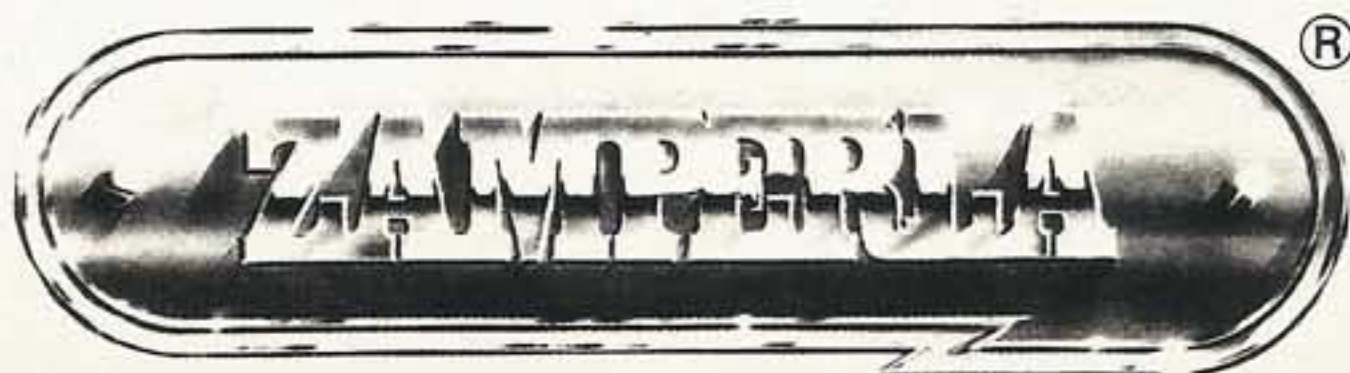

**Plan
your newest
attraction
around
EURO-MATIC®
Playpen Balls!**



HERSHEY PARK

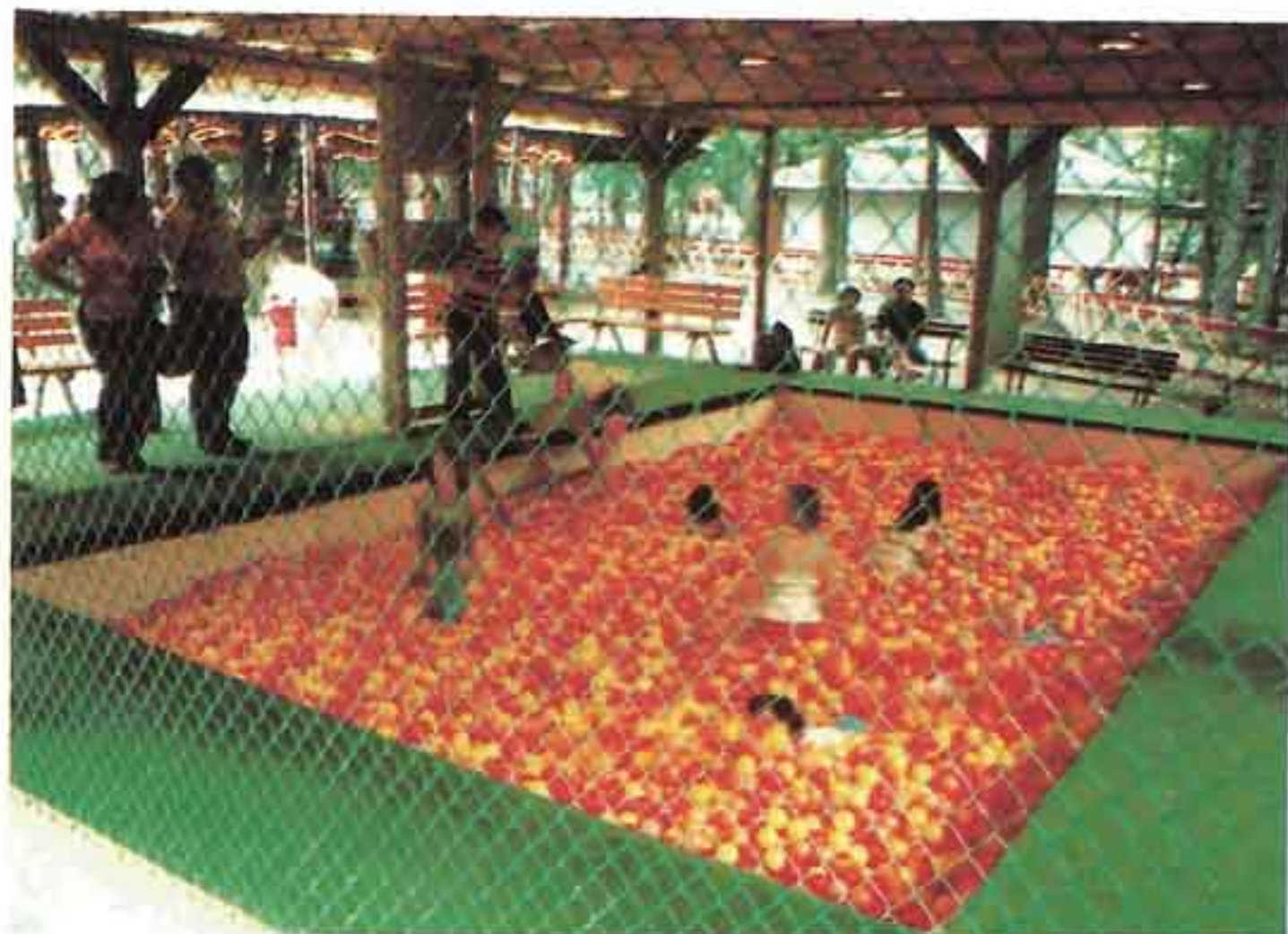
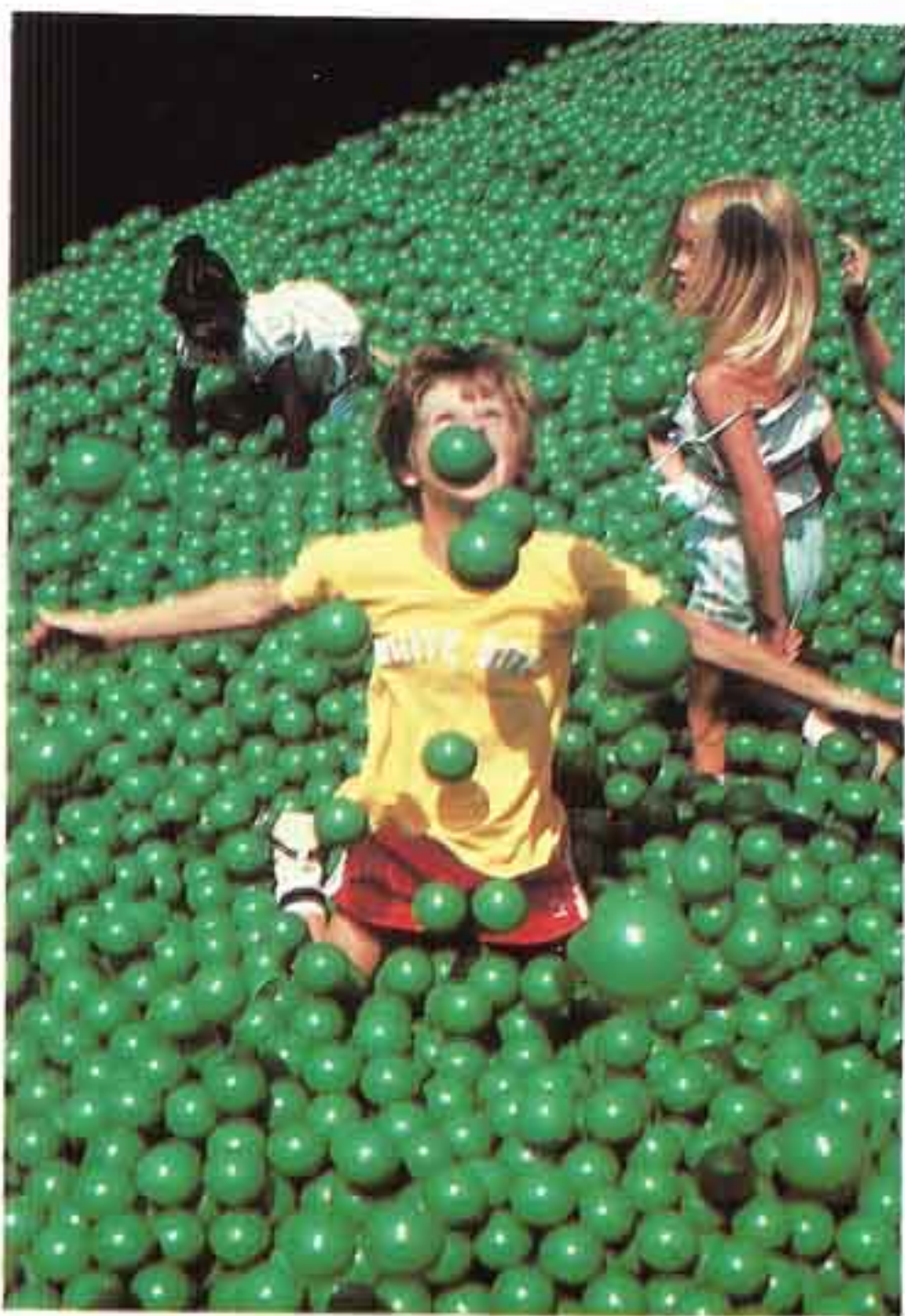

KNOEBELS GROVES

SESAME PLACE



*attracts kids
like bees
to honey!*

A photograph of children playing in a ball pit filled with blue balls. The scene is enclosed in a chain-link fence. In the foreground, a girl is lying on her back, and two boys are standing and playing. In the background, other children and adults are visible through the fence. The text 'a great new way to play' is overlaid in yellow at the top.

**a great new
way to play**

...THAT PAYS!

SILVER DOLLAR CITY

a small playpen area filled with **EURO-MATIC[®]**

PLAYPEN BALLS
... attracts kids like bees to honey!

Ideal attraction for:
THEME PARKS
SUMMER CAMPS
RESORTS
CARNIVALS
FAMILY RESTAURANTS
... and more!

This new play sensation is now being featured at some of the most popular theme parks in the USA: Silver Dollar City... Hersheypark...
*Sesame Place, Marineland, Inc, and others.

What the parks do is fill a playpen with Euro-Matic[®] Playpen Balls. It attracts children by the score!

Euro-Matic[®] Playpen Balls are brightly coloured hollow pressurised lightweight plastic balls about 3 inches in diameter.

Once inside they romp and 'swim' through a sea of thousands of balls. Eye-appealing! Exciting! Very economical too. Requires less maintenance and supervision.

Call or write today for more details and quotations.

*Sesame Place is the copyright name of Children's Television Workshop

EURO-MATIC LTD

6 colours available:



98 ADAMS STREET, LEOMINSTER, MASSACHUSETTS 01453. TEL: 617-537-8274



Aquabike[®] International

AUSTRALIA

U.S.A.

CANADA

ITALY

JAPAN

NEW ZEALAND

PTY. LTD
MALAYSIA

INTRODUCES ANOTHER REVOLUTIONARY PRODUCT FOR
THE LEISURE AND TOY INDUSTRIES

THE

TWISTA[®]



THE SPACE AGE FUN MACHINE FOR THE WHOLE FAMILY TO ENJOY

THE TWISTA IS GREAT FUN TO RIDE, AS IT CAN BE MANOEUVRED BACKWARDS, FORWARDS, SPIN ON ITS AXIS. YOU CAN TAKE OFF AT ANY ANGLE, BUMP INTO THE TWISTA IN FRONT OF YOU OR TRY TO GET AWAY FROM ANOTHER TWISTA TRYING TO BUMP YOU.



OUR Pedalcat 86

a space age version of the traditional pedal boat, but designed and built with modern materials, making it a heavy duty work horse, light but strong, manoeuvrable, reliable and attractive with marine grade aluminium hulls, one piece fibreglass seat, twin "V" belts drive and all stainless steel pedal cranks, axles, bolts, for minimal maintenance and maximum returns.

The special features of our pedal boat that make it more expensive, but far superior for the hire business are,

- a) the rear drive paddle wheel gives positive propulsion against winds and currents, a variable portion of the blade enters the water depending on body weight making it easy for children to pedal.
- b) The **high impact polyethylene tips and aluminium hulls** save you time and money as you don't have to continually patch and paint them.
- c) Many parts are interchangeable with our other products the Aquabike and Twistas so you only need to keep a small stock of spare parts.

Length 3,500mm; Width 1,250mm; Height 1,000mm.



TWISTA

A Pedal Driven Bumper Car

The **TWISTA** is great fun to ride, as it can be manoeuvred backwards, forwards, spin on its axis. You can take off at any angle, bump into the **TWISTA** in front of you or try to get away from another **TWISTA** trying to bump you. Because of the amazing manoeuvrability of the **TWISTA** it is possible for it to be used in an extremely small area, 10 can be run in a 20' x 20' space.

The **TWISTA'S** pedal power makes it virtually noiseless, non-pollutant and basically maintenance free, making it ideal for a profitable rental business anywhere there are people and a smooth surface.

Maximum age 12 years or 60kg.

* WE CAN AIR FREIGHT ALL OVER THE WORLD, ANY PART YOU MAY REQUIRE



Aquabike International

PTY. LTD. Est. 1947

Factory and Office: **129 GLADSTONE STREET, FYSHWICK, CANBERRA, A.C.T. 2609 AUSTRALIA**

Telephone: (062) 80 4393 — International 61-62-804393 — Telex: AA 62335 AQUABI

EXPORT
AWARD





Aquabike[®] International

AUSTRALIA NEW ZEALAND ITALY UNITED STATES CANADA JAPAN MALAYSIA

INTRODUCE A NEW CONCEPT IN WATER SPORT

THE *Aquabike* MK III

A TRICYCLE TO TRAVEL ON WATER



THE AQUABIKE IS IDEAL FOR THE BOAT HIRE INDUSTRY AS EVERYONE FROM 6 to 60 CAN USE IT WITHOUT ANY PREVIOUS EXPERIENCE REQUIRED.



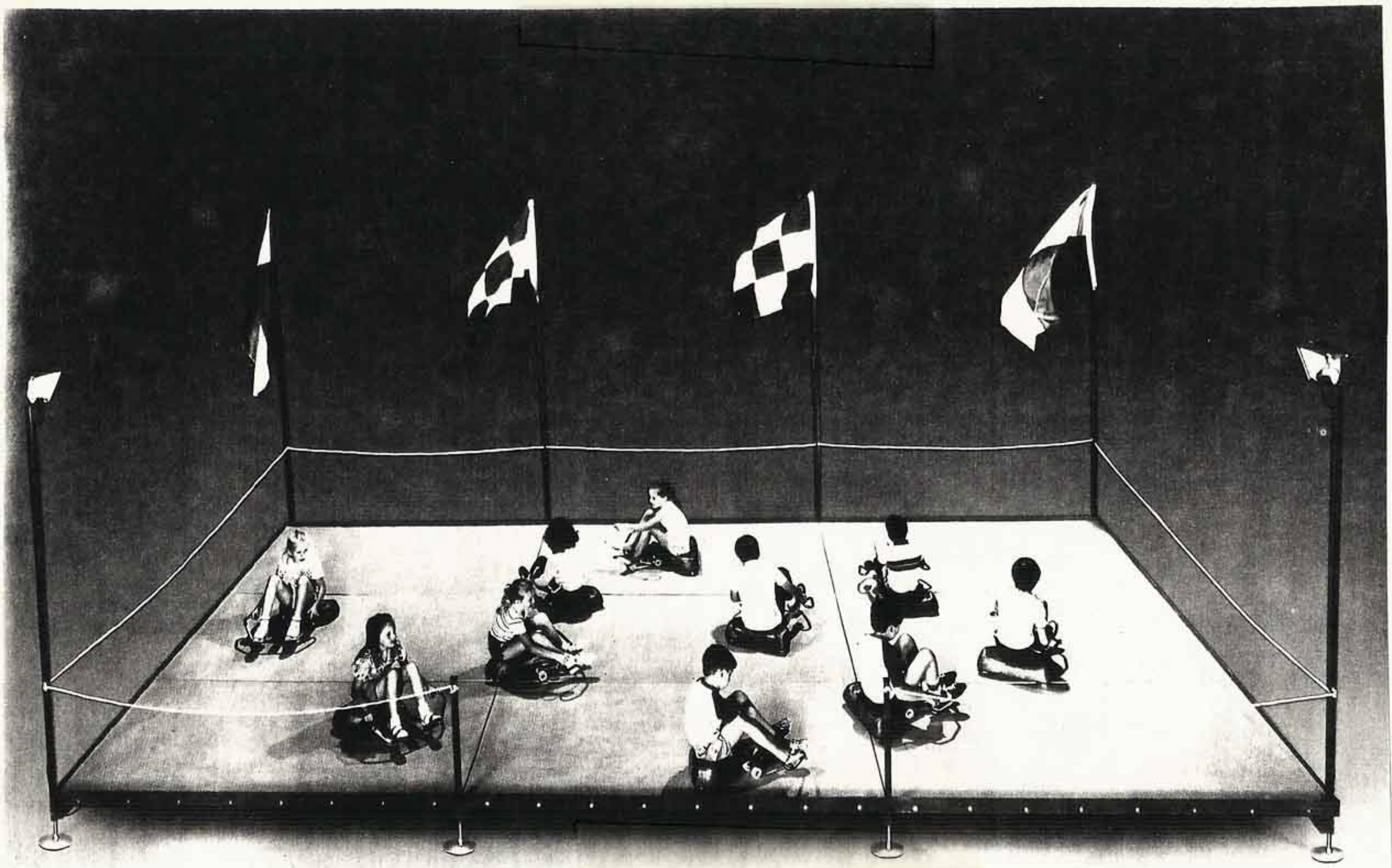
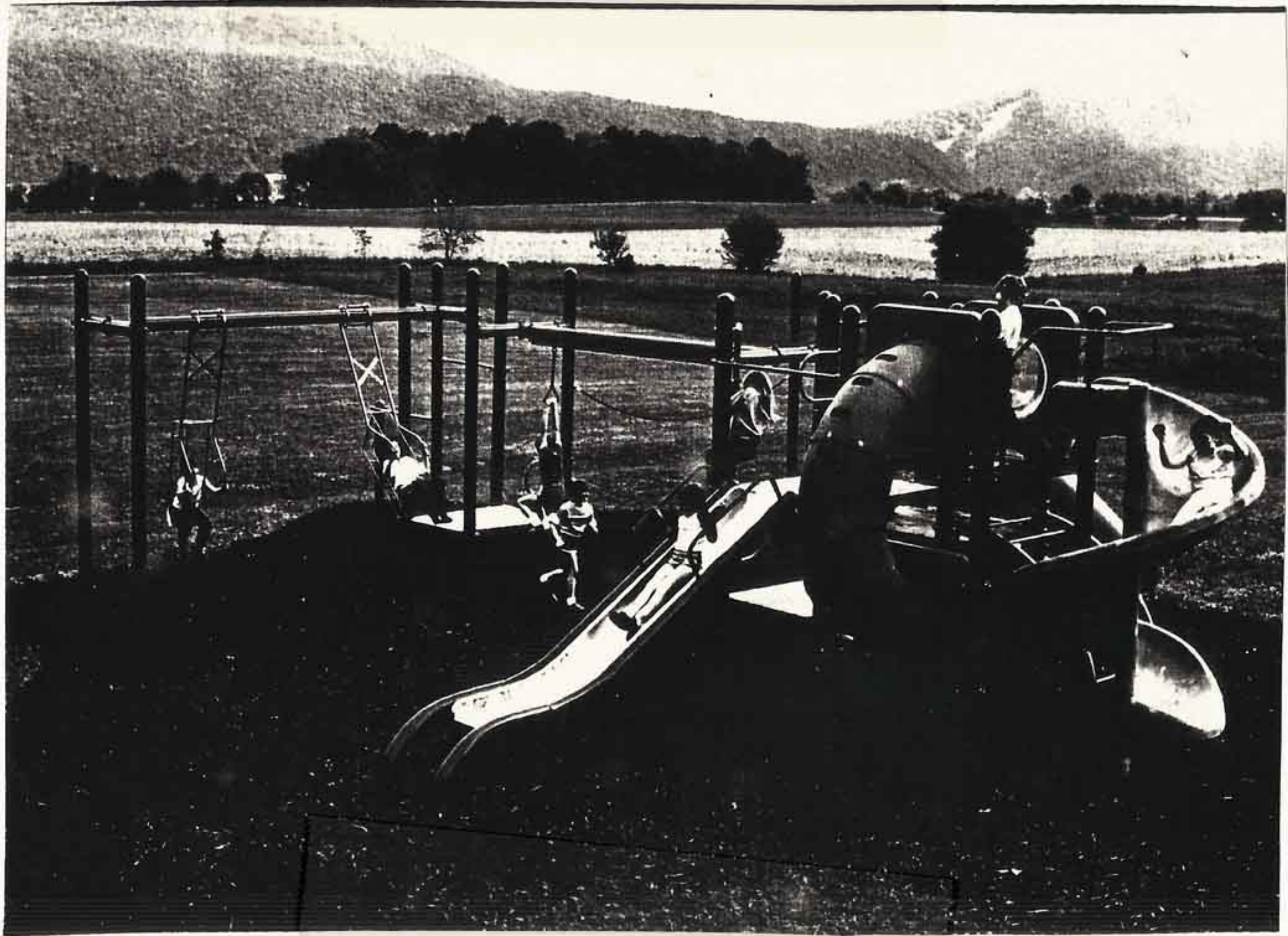

FAR WEST TRAIN

CATERPILLAR TRAIN

WORK INDOORS OR OUTDOORS. ALL YEAR LONG. THESE CROWD PLEASERS HAVE THE KIDS STANDING IN LINE AND ARE GUARANTEED TO GENERATE BIG PROFITS. DESIGNED FOR SHOPPING CENTERS, RESORT AREAS AND SMALL AMUSEMENT PARKS, THESE ATTRACTIONS WILL DELIGHT ANY CROWD WITH A MINIMUM INVESTMENT FROM YOU.

PORKIES



FAR WEST: FASHIONED AFTER THE REAL THING, THIS MODEL IS A PROVEN PROFIT-MAKER. LIGHTS AND SOUND EFFECTS ARE INCLUDED AND THE SPEED IS OPERATOR-CONTROLLED. STANDARD MODEL: 1 ENGINE CAR AND 3 WAGONS. TOTAL CAPACITY: 25

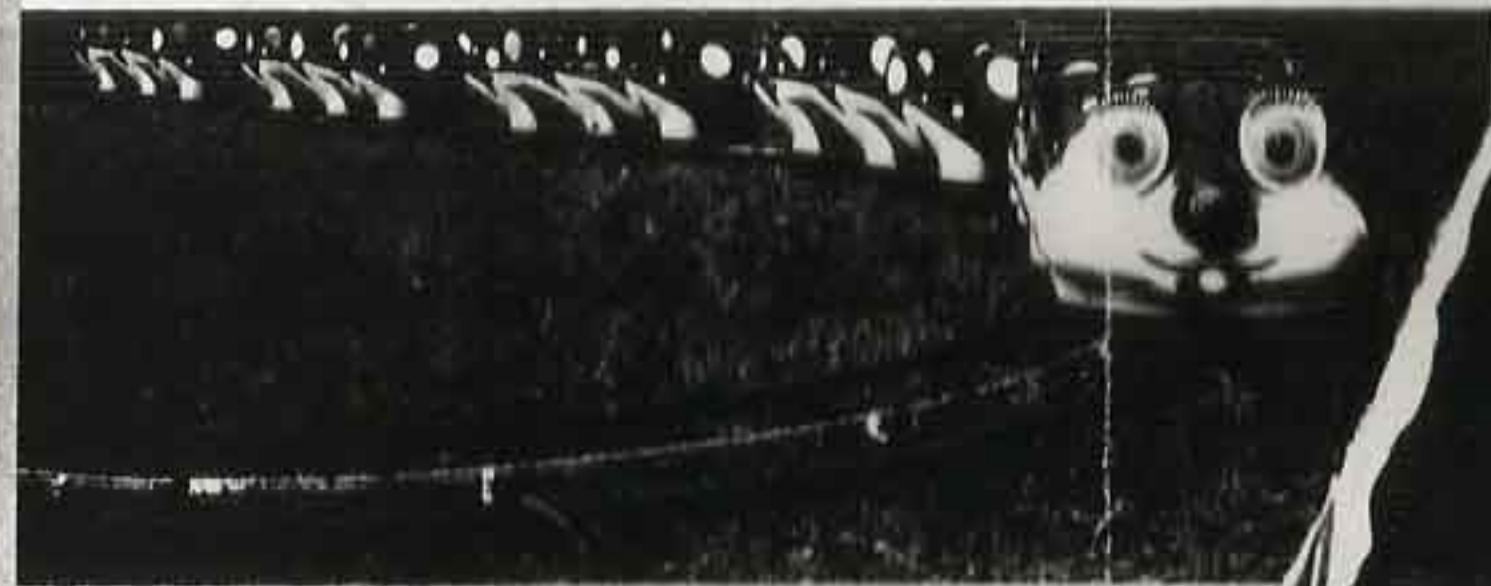

CATERPILLAR: THE COLORFUL, FIBERGLASS BODY, SOUND AND LIGHT EFFECTS MAKE THIS RIDE A REAL WINNER. AN EXCLUSIVE SYSTEM OF ELECTRICAL CONTACT THROUGH THE RAIL POWERS THE TRAIN SAFELY AND EFFICIENTLY. STANDARD MODEL: 1 ENGINE CAR AND 4 WAGONS. TOTAL CAPACITY: 28

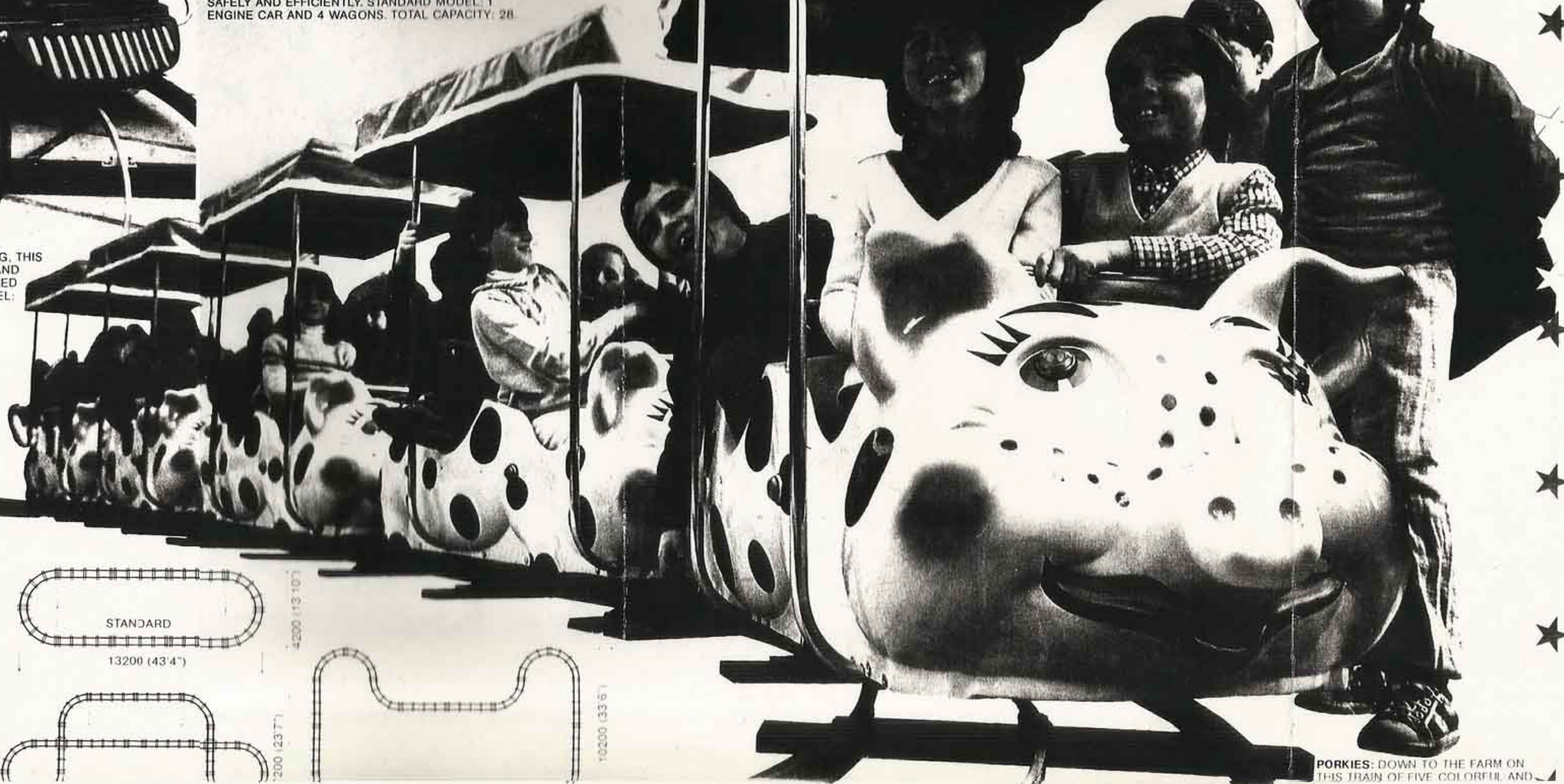

PORKIES: DOWN TO THE FARM ON THIS TRAIN OF FIVE COLORFUL AND...

GENERAL SPECIFICATION:
 STANDARD TRACK SIZE: 40 FT x 14 FT
 STRAIGHT AND CURVED RAIL: 10 FT EACH
 TURNING DIAMETER: 180 DEGREE 14 FT
 DRIVE POWER: SINGLE PHASE 110 V 60 HZ
 1 KW
 WEIGHT HEAD CAR WITH 4 MOTORS 250 LBS
 1 WAGON 110 LBS
 1 RAIL PIECE 55 LBS

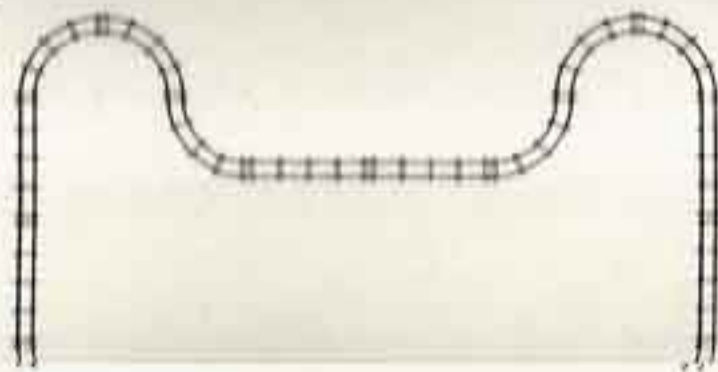
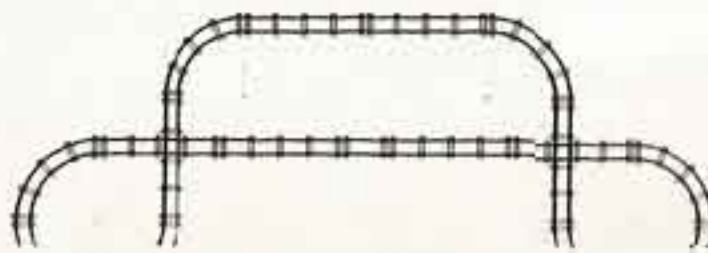
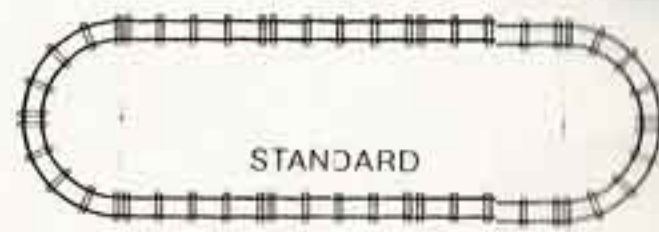

10100 (33'0")

10200 (33'6")

10200 (33'6")

13200 (43'4")

ANALYSIS OF NEW ATTRACTION POTENTIAL

Parent/Child Interactive Area

STRATEGY

- Improves the adult experience.
- Maintains or improves the child experience.
- Does not diminish the restaurant perception.
- Offers new or novel form of entertainment.

Yes

Yes

Yes

★ ★ ★ ★ ★ ★ ★ ★ ★ ★
NEW
ENTERTAINMENT
ATTRACTION
★ ★ ★ ★ ★ ★ ★ ★ ★ ★

TIME
&
COST
FACTORS

- Are development costs required?
How long? - How much?
- Can it be cost effectively adapted to locations?
- What is the time frame for field testing?
- What is the time frame for rollout?
- Are special installation skills required?
- What are anticipated maintenance costs?
- What are software support costs?
- What is projected R.O.I.?
- What will its' life be after 100% R.O.I.?

Maybe



PLAY PAYS!

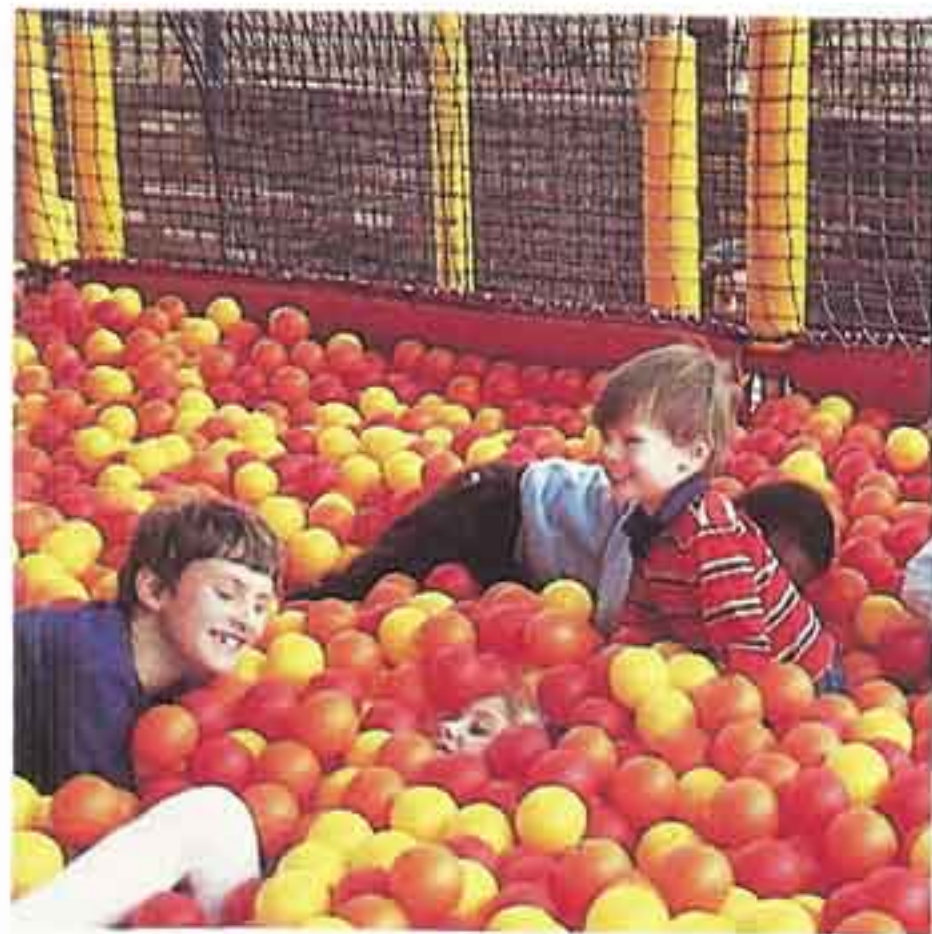

approach to presenting play at fast food facilities. PLAYPORT equipment is 180 degrees from municipal equipment. It is soft, made in a variety of plastics, foams and vinyls on a strong modular steel frame. All play occurs within protective netted and padded play event areas. PLAYPORTS look distinctive because they are unique in their planned protective approach to play. Parents are constantly concerned about the well-being of their children while at play. They immediately perceive PLAYPORTS as providing play events carefully designed to prevent mishaps. They feel good about their children playing in

Question:

"When is a playground a sales marketing tool?"

Answer:

"When it's a PLAYPORT, the world's proven leader in capturing and holding family business at fast food facilities."

Here's why. When play areas began to pop-up on fast food lots they offered little more than a duplication of the municipal play equipment found at a city park or school yard, spruced up with bright colors, maybe some fiberglass dressing, and a logo sign. The kids knew it was the same stuff they were playing on already. Many of them had the bumps and bruises to prove it. A familiar lament of many fast food operators who invested in playgrounds sounded something like this, "Well, we put in the playground but after about two months it just sorta died." Others said, "In the summer you could fry eggs on that stainless steel slide; it was so hot that the kids couldn't use it." These playgrounds were not perceived as being either very exciting or even particularly safe. They weren't, and there were reasons for it. The play equipment manufacturing industry simply adapted existing stock municipal equipment and dolled it up for sale to the fast food industry with no research, no serious design or innovation. It was a matter of fitting what they were already making to the spaces available.

PLAYPORT has changed the entire

"... In the summer you could fry eggs on that stainless steel slide; it was so hot that the kids couldn't use it."

a PLAYPORT. The children can experience creative and imaginative play events without fear of being hurt by the equipment.

PLAYPORTS are the creation of Pentes Design, Inc., an industrial design firm with thirty-five years of

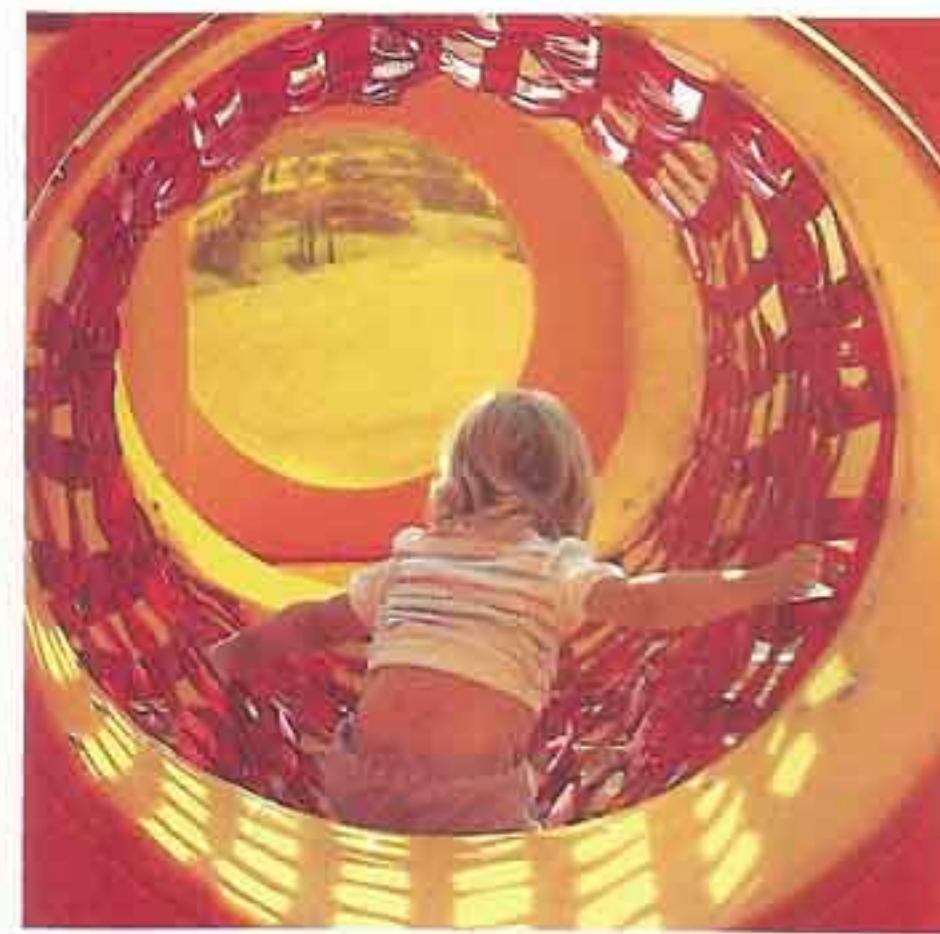
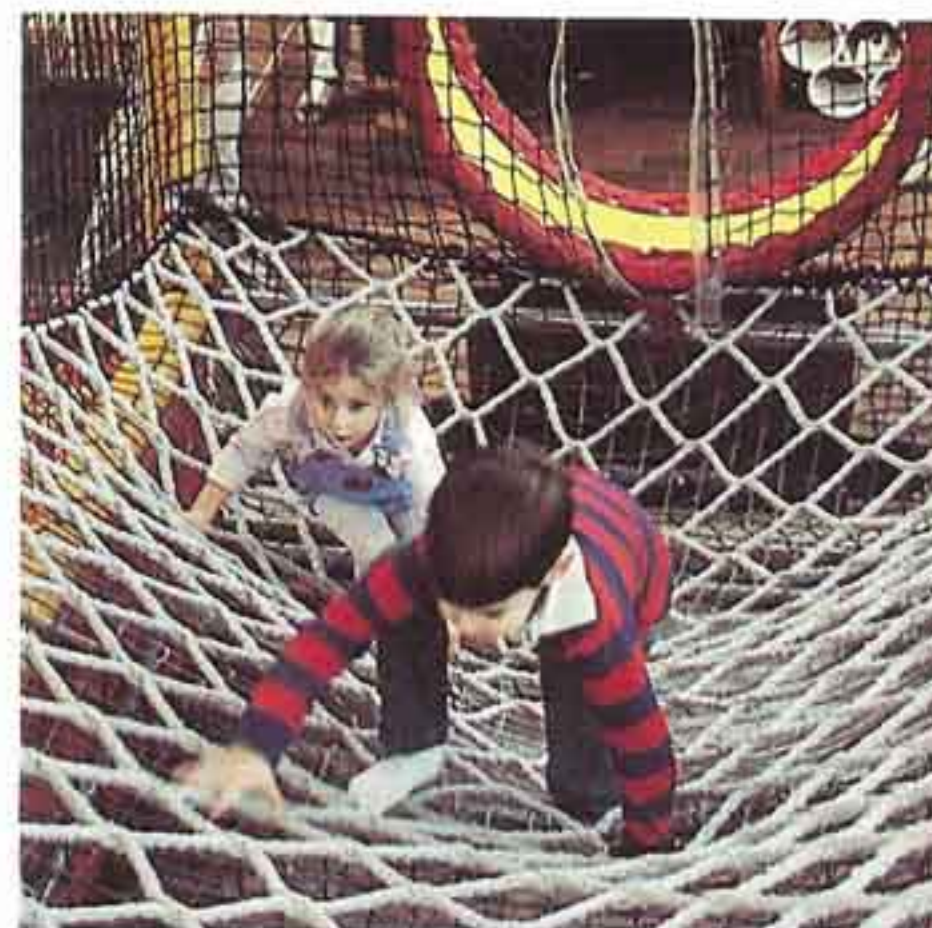

successful practice. Over the past three decades, the Pentes group has enjoyed great acceptance with scores of award winning projects noted for child appeal. PLAYPORT has benefitted from the Pentes understanding of what children like and want. PLAYPORTS have been called the playgrounds of the twenty-first century. PLAYPORTS were pioneered, field tested and proven in the largest theme parks and attractions in America. These "pay for play" installations have been overwhelmingly successful and provided generous returns. These designs have been compacted for use in small spaces, especially for the fast food industry. Every store installation with a PLAYPORT has increased sales beyond all projections. A PLAYPORT at a fast food location will attract and hold all the available family business within the store's range. This business is retained for good. Studies at actual locations have proven PLAYPORT stores literally clean out the kids from the competitors locations. Once children experience PLAYPORT they do not want to go anywhere else, and the parents comply. A PLAYPORT can double fast food dining room business and increase birthday party bookings over five times. It's being done today.

Why do children and parents like PLAYPORTS so much? Because of the original and exciting play events. The Ball Bath, a soft springy pit filled with as many as 17,000 hollow plastic balls is

Proven Gross Increases up to 40% Capture and Retain the Family Business

a most innovative play device. Children and adults (parents are invited to play in the PLAYPORT with their children) can swim, roll, wallow and gyrate in the Ball Bath. They can toss balls at a hoop and target and roll on a three-foot pit ball. The rope cargo climb leads to the upper level of all PLAYPORTS. Kids love to climb, and this they do to get into the Pipeline Crawl. This event connects the bright yellow Junction Boxes by way of colorful nylon web crawling tubes. The Boxes contain talking tubes for communication as well as large periscopes and kaleidoscopes. They have been described as "tree houses" and children love to snuggle into their color-tinted bubbles. The long, clear domed tube slide brings kids down to the ground level where they can enjoy the "Walk-on-Water" experience, the Tube Bounce and Boppity Bags. On the Flying Turtle track children can sit on a roller seat with handlebars and propel it forward just by moving the bars from side to side—like a bumper car without a motor! These play events are new and they never get boring. It's estimated that the seventy-five children playing in a 18' x 30' PLAYPORT would need

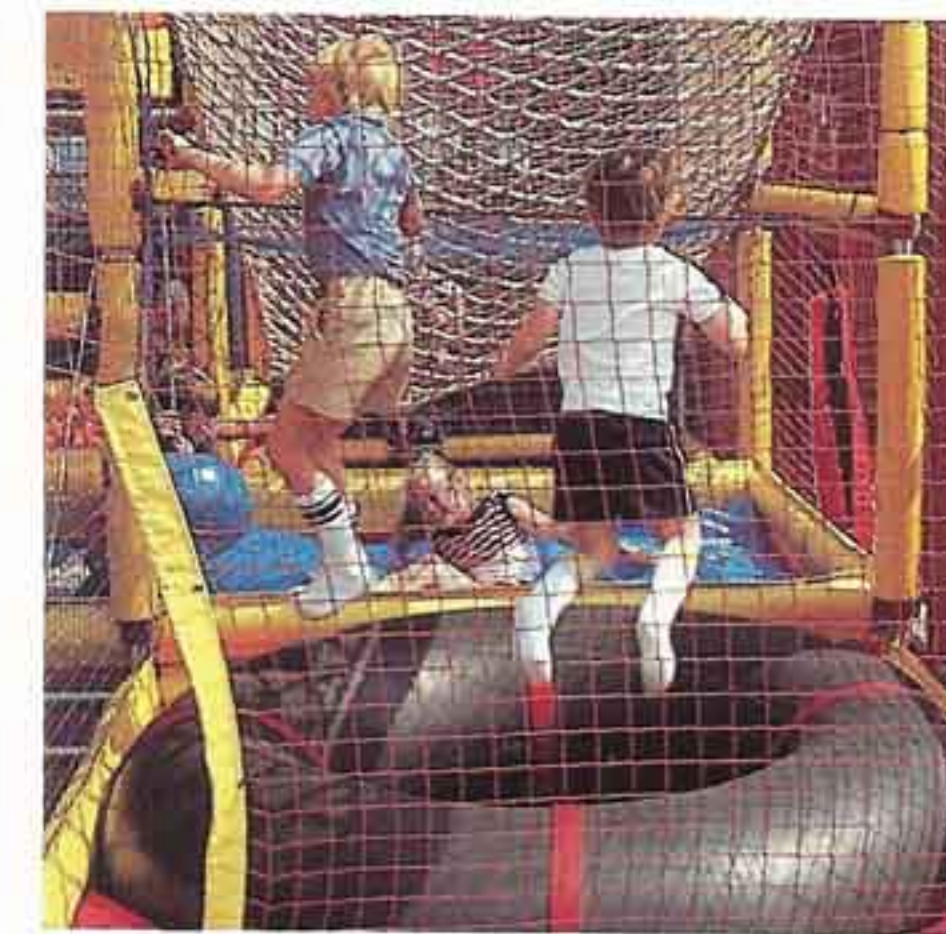

Once children experience Playport they do not want to go anywhere else and the parents comply.

an acre of ground space using conventional equipment.

The catch? There is none when the operator uses his PLAYPORT as a marketing tool. The PLAYPORT is an extension of the store and must be kept just as clean and in excellent repair. PLAYPORT offers cleaning and operating manuals and a maintenance and parts contract designed to help keep a PLAYPORT in like-new condition. A special manual of "PLAYPORT Games" allows operators to use the PLAYPORT for promotional events. Birthday party bookings soar at PLAYPORT stores and parents comply with their

children's request to have a PLAYPORT birthday party. A PLAYPORT blows the competition out of the water.

PLAYPORTS have been designed to fit all kinds of spaces. Delivery is eight weeks from contract receipt and erection is provided by skilled installers. The store commits to keep the PLAYPORT as clean as the store. Mechanical maintenance is provided every two weeks by skilled local maintenance personnel. PLAYPORTS cost more than conventional play equipment for a reason. Carefully designed, they provide much more play value and use non-conventional materials. PLAYPORTS offer higher play capacities and high street visibility. They contain instructional signage for in-store display. All PLAYPORTS are supplied with shoe cubbies for shoe storage (kids play shoeless) and a sign illustrating shoe cubby use. Tray liners, advertising photography and line art is available. PLAYPORT buyers are not forgotten once the sale is made. They are provided with monthly maintenance inspection reports that contain data on cleanliness and maintenance performed. PLAYPORTS Pay!



© Pentes Design Inc.

PLAYPORT

PENTES DESIGN INC. • 1346 Hill Road • Charlotte, North Carolina 28210 • (704) 552-5400

PLAYPORT

FREE PLAY 1



This is the Flagship PLAY-PORT offering high capacity play for children and their parents. Available with optional sunscreens or rain deflecting canopies with a full spectrum of

play events that will work for your family business and an unexpected busload of patrons at the same time. Designed to fit a 30' x 40' pad, the unit can be accommodated on a smaller pad by

deleting or relocating the Flying Turtle track. Numbers is the name of the game and this crowd absorber will attract and hold both the numbers and sales you want. This unit does it for you!

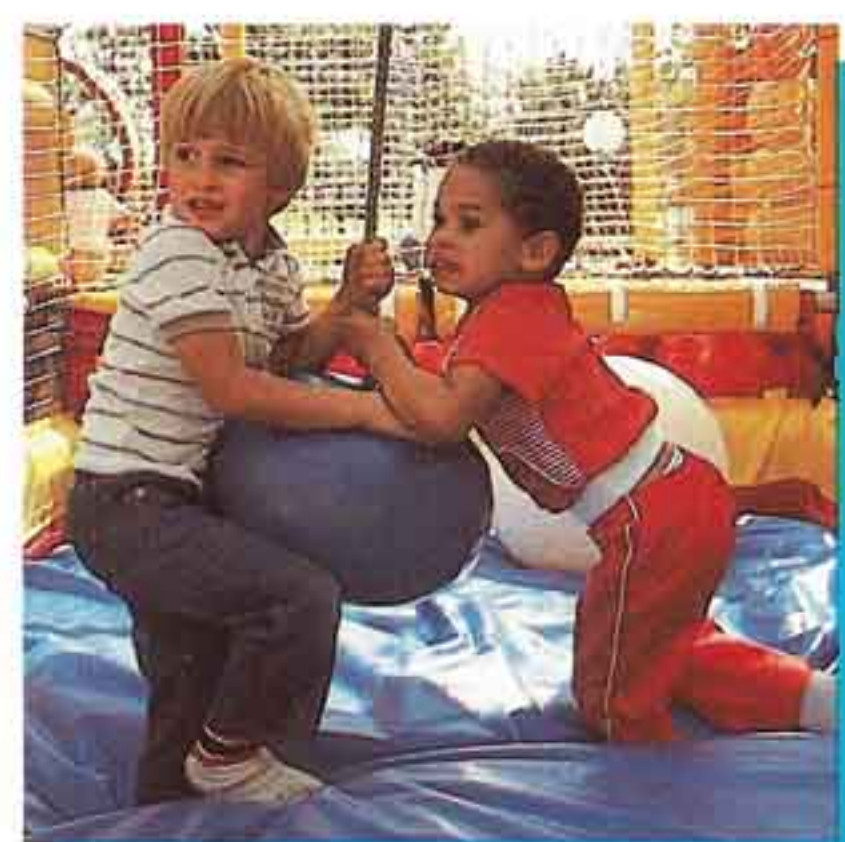
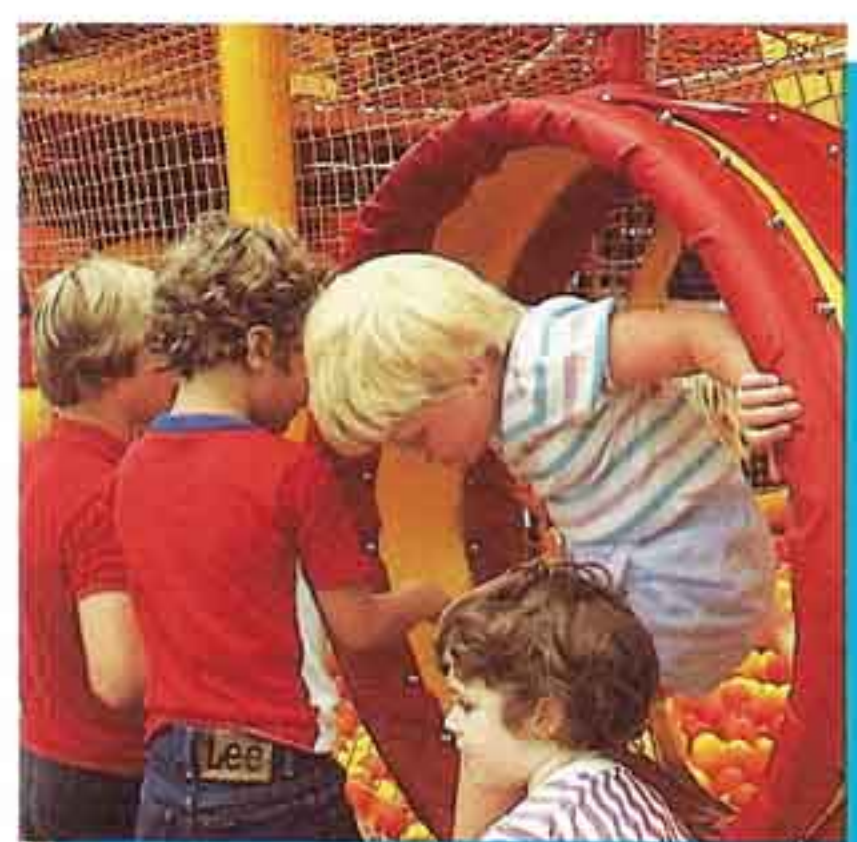
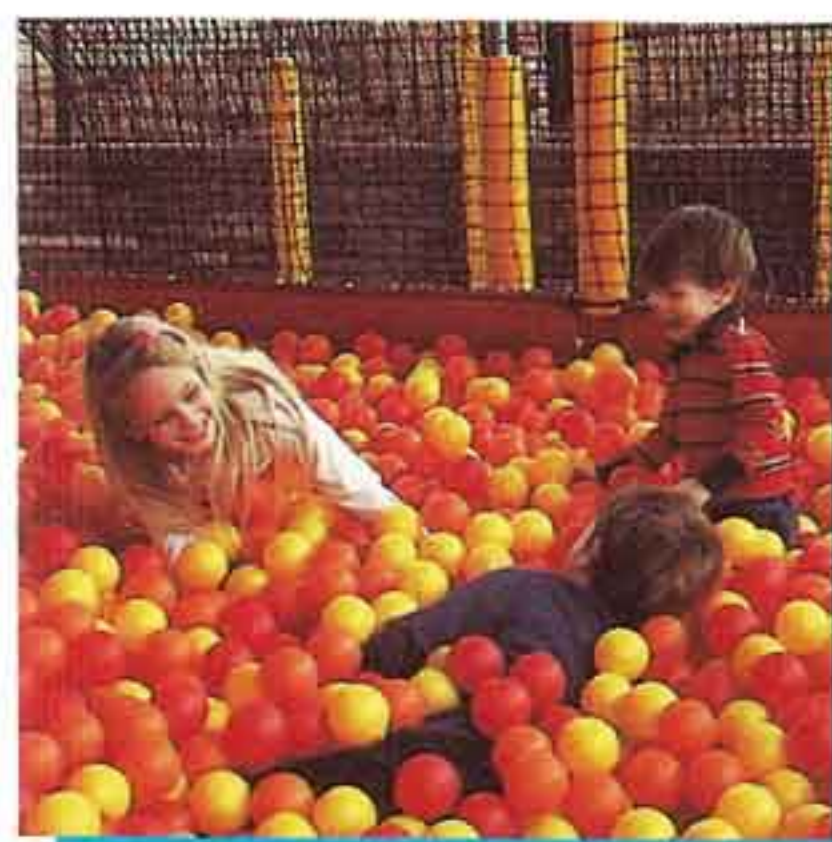

FREE PLAY 1

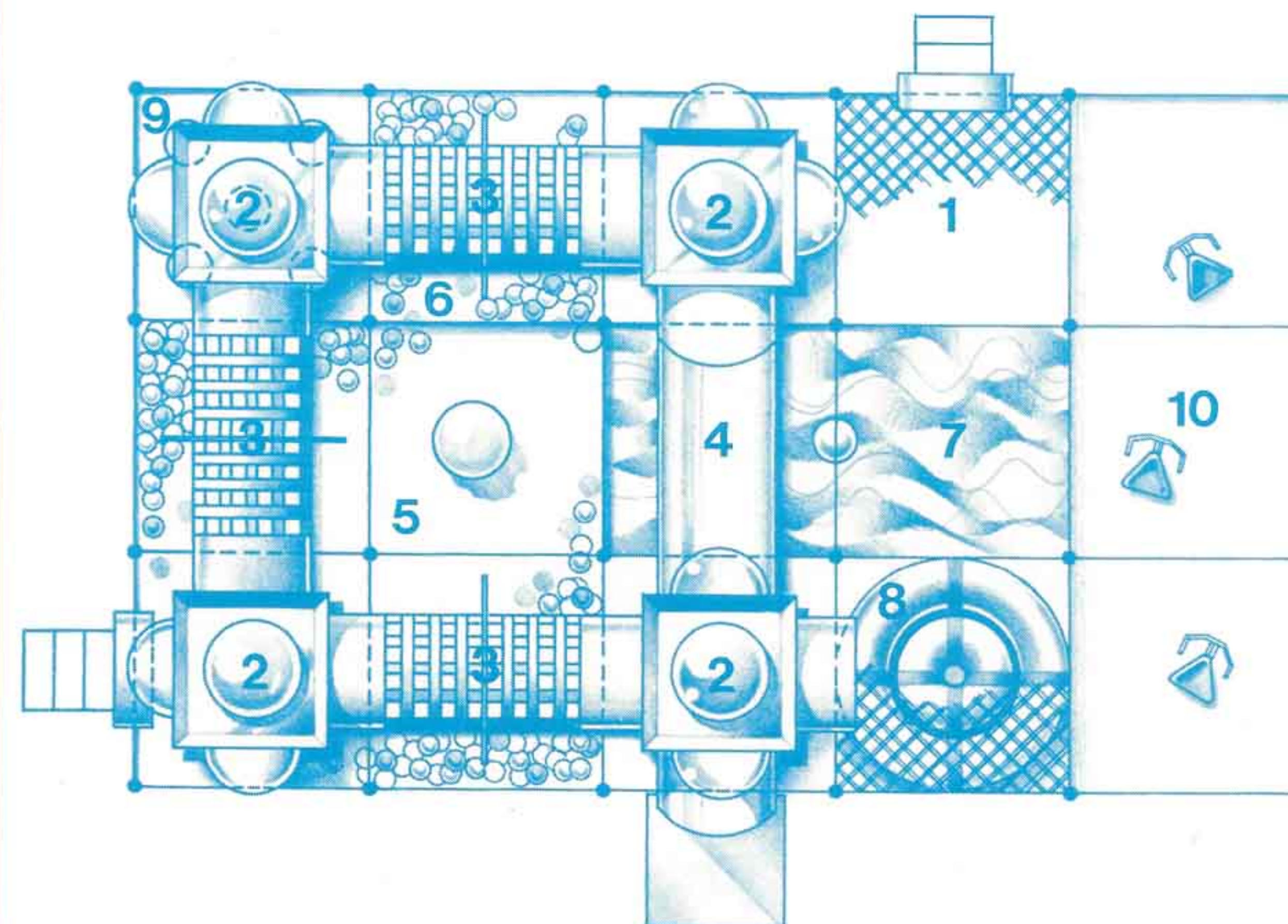

18' x 24' (18' x 30' with optional Turtle Track)
Capacity 75

Prices and specifications subject to change without notice. ©Pentes Design Inc.

KEY

- 1—Cargo Climb
- 2—Junction Box
- 3—Web Crawl
- 4—Super Slide
- 5—Ball Bath
- 6—Baby Ball Bath
- 7—Walk on Water
- 8—Tube Bounce
- 9—Boppity Bags
- 10—Turtle Track (optional)

ACCESSORIES

- Ball Target
- Ball Hoop
- Big Ball
- Boppity Bag
- Kaleidoscope
- Periscope
- Talking Tube

PLAYPORT

FREE PLAY IV



Designed to attract, this mid-sized PLAYPORT offers both good looks and good play capacity for your family business. Available with an optional 6' x 18' Flying Turtle track, as well as

sunscreens or canopies. A Baby Ball Bath for toddlers will please parents with children under three. A 30' x 30' pad will allow excellent "run-around" room and the two high rise Junction Boxes

will really attract street traffic. Children can spot and know that a PLAYPORT is their turf. Once they take possession for the first time they will insist on returning time after time.



FREE PLAY IV

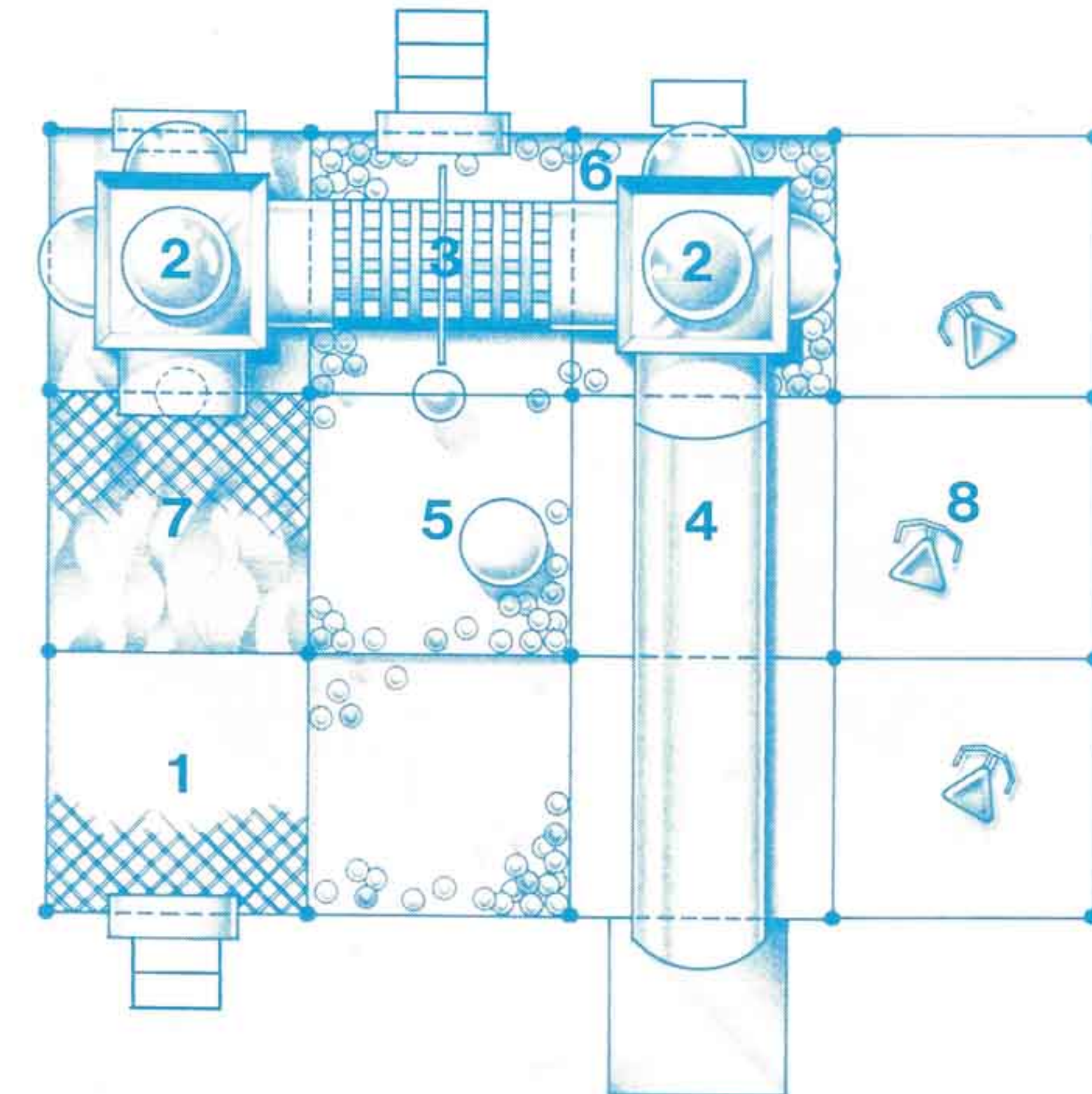

18' x 18' (18' x 24' with optional Turtle Track)
Capacity 45

Prices and specifications subject to change without notice. ©Pentes Design Inc.

KEY

- 1—Cargo Climb
- 2—Junction Box
- 3—Web Crawl
- 4—Super Slide
- 5—Ball Bath
- 6—Baby Ball Bath
- 7—Walk on Water
- 8—Turtle Track (optional)

ACCESSORIES

- Ball Target
- Ball Hoop
- Big Ball
- Boppity Bag
- Kaleidoscope
- Periscope
- Talking Tube

PLAYPORT

FREE PLAY V

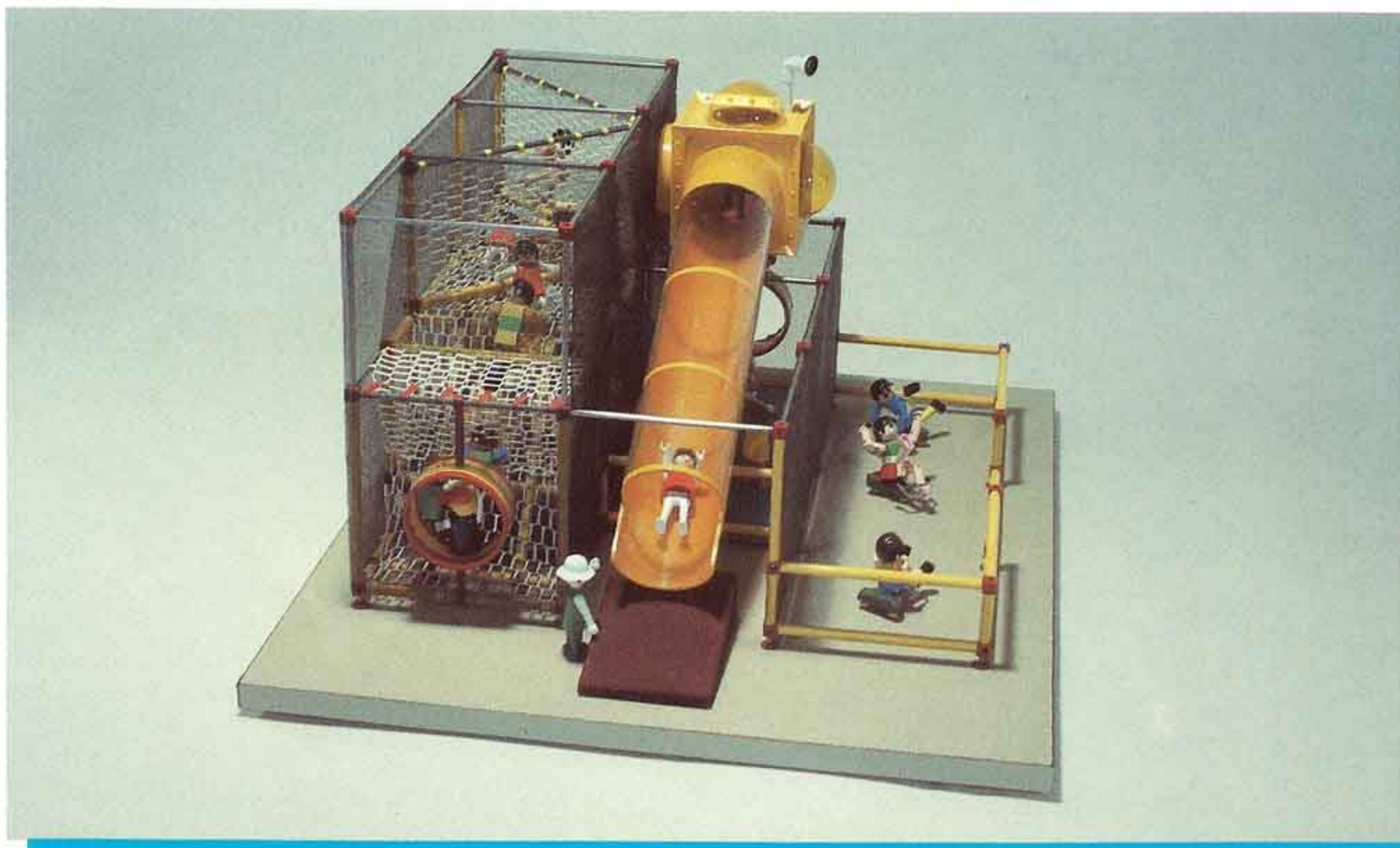

Planned for small sites and tight budgets, this compact PLAYPORT is every bit as attractive and fun-filled as its bigger brothers. Every inch of space has been used to give a full range

of play events to your family business. Used as a 12' x 18' PLAYPORT or with an optional 6' x 18' Turtle Track, it can be fitted to almost any site where space is at a premium. Sun-

screens or canopies will add color and limited shelter for all but the wettest and snowiest days. Despite its size it offers good capacity and high street visibility.

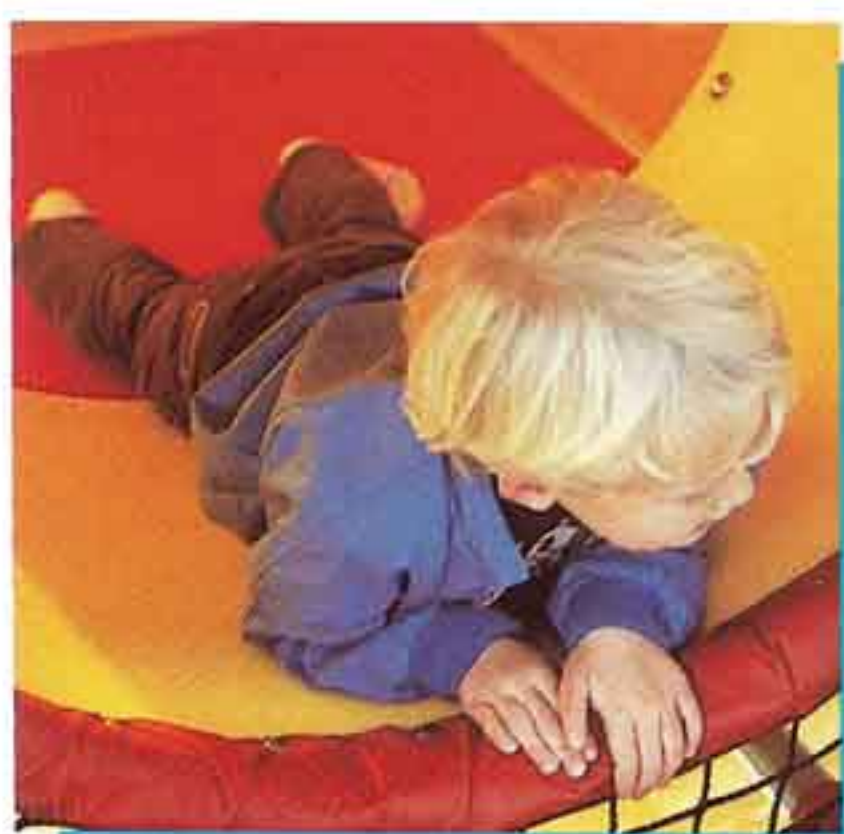

FREE PLAY V

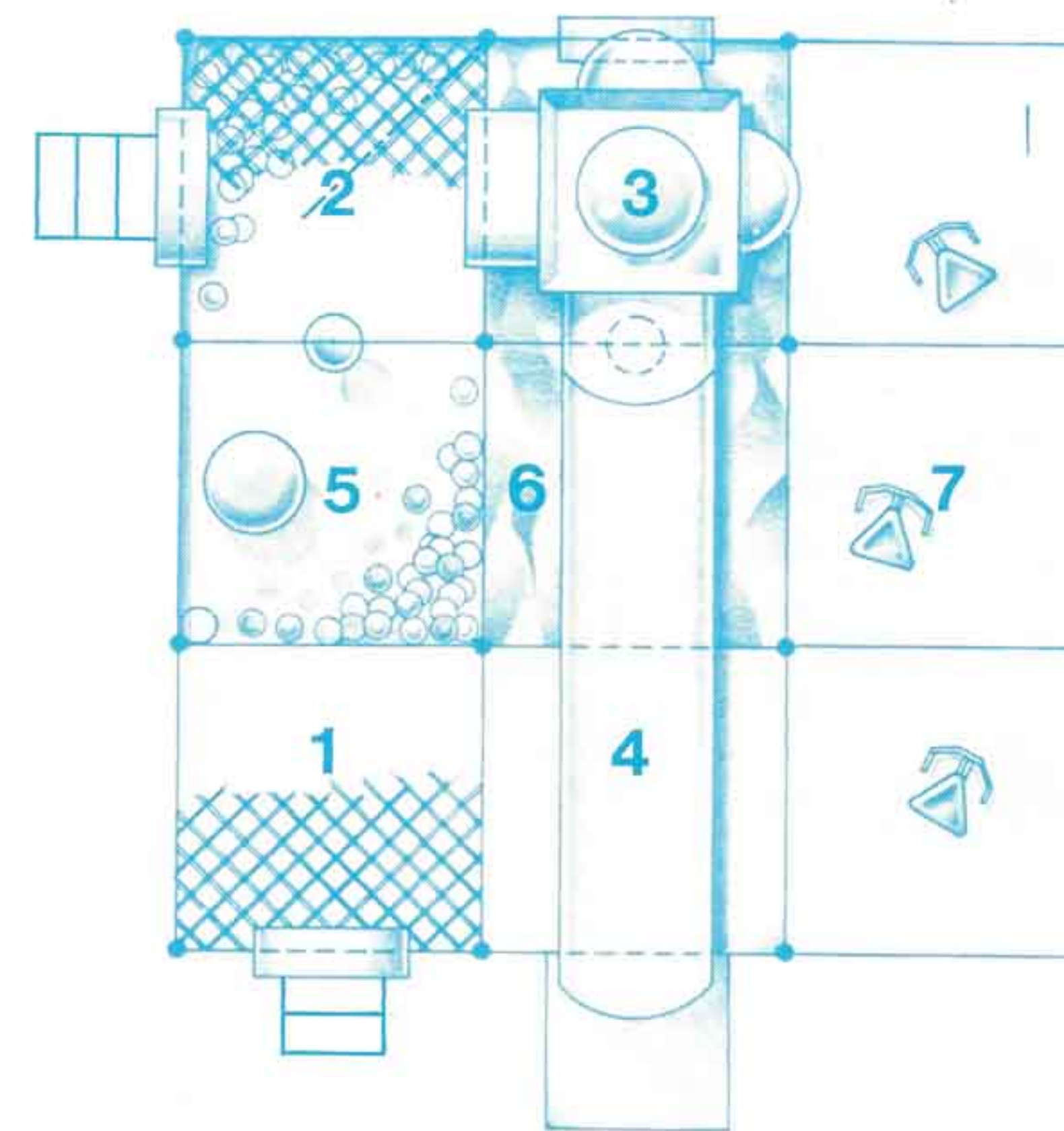

12' x 18' (18' x 18' with optional Turtle Track)
Capacity 30

Prices and specifications subject to change without notice. ©Pentes Design Inc.

KEY

- 1—Cargo Climb
- 2—Spider Web
- 3—Junction Box
- 4—Super Slide
- 5—Ball Bath
- 6—Walk on Water
- 7—Turtle Track (optional)

ACCESSORIES

- Ball Target
- Ball Hoop
- Big Ball
- Boppity Bag
- Kaleidoscope
- Periscope

PLAYPORT

PIPELINE CRAWL

Photo shows typical section of Pipeline Crawl.



Pipeline Crawl, a PLAYPORT original, is made for kids! Web Crawls, enclosed Tube Crawls, and Junction Boxes are interconnected to form a unique series of passages for kid-sized activity. These passages turn corners to form the ulti-

mate hide and seek play element. Kids explore this crawl through maze with high interest and curiosity. Junction Box play spaces provide viewing of the "outside world" through colored bubble domes along with a unique

communication network through box to box tube phones. The Pipeline Crawl features six Junction Boxes with interconnecting passages. Various configurations are available to fit specific layouts.

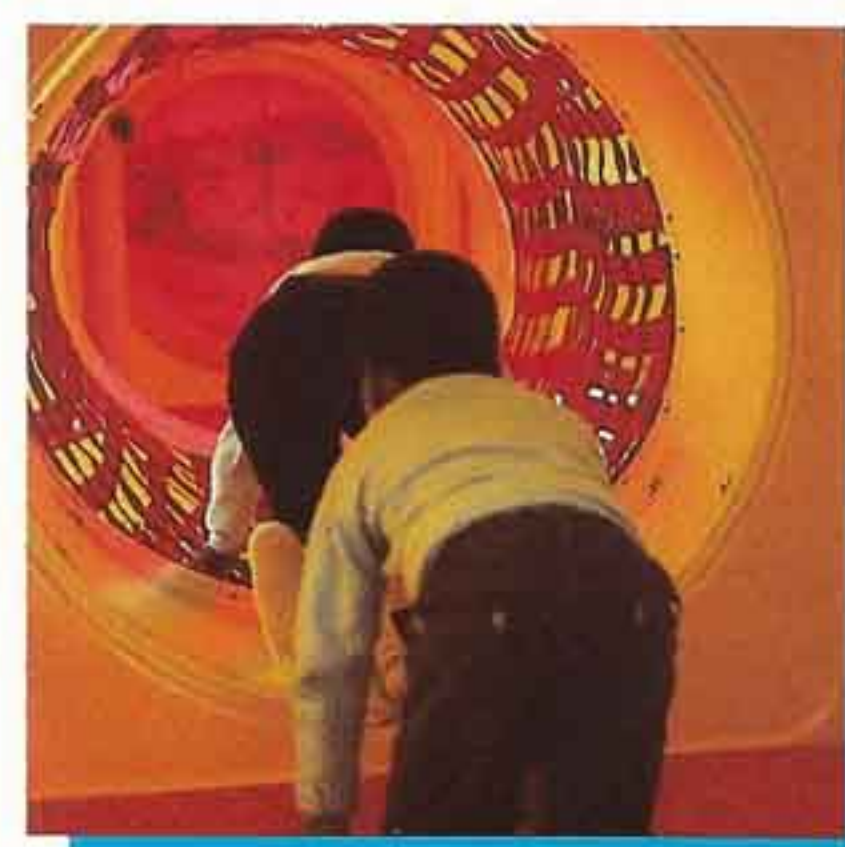
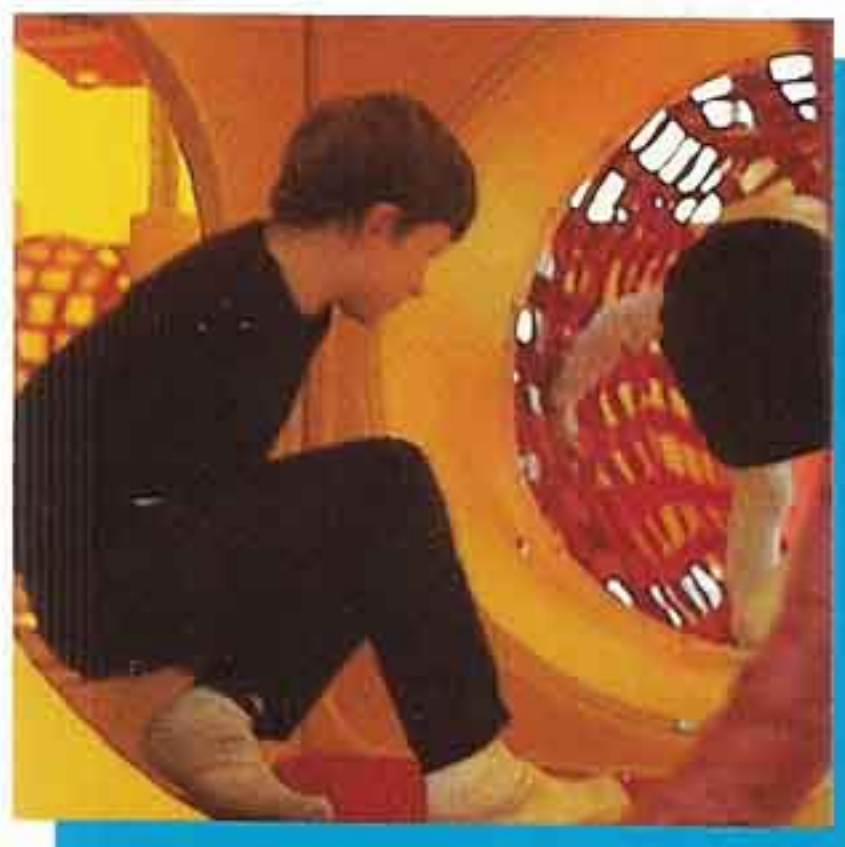

PIPELINE CRAWL

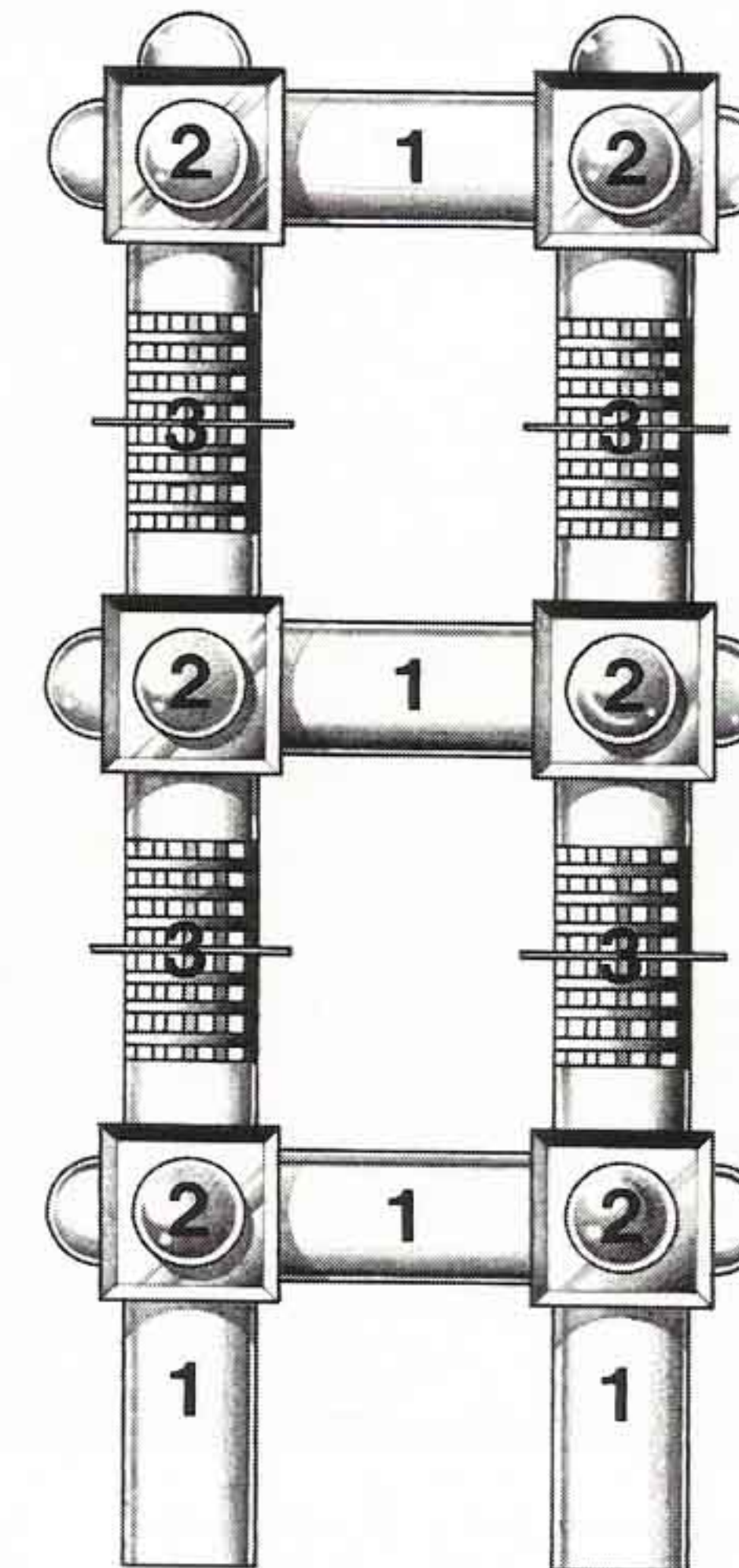

16' x 35'
Capacity 30

Prices and specifications subject to change without notice. ©1985 Pentes Design Inc.

KEY

- 1—Tube Crawl
- 2—Junction Box
- 3—Web Crawl

ACCESSORIES

- Talking Tube
- Periscope
- Kaleidoscope

PLAYPORT

MINI-PLAY I



Targeted for outdoor or indoor use under ceilings as low as seven feet six inches, this PLAYPORT is excellent for use in restaurants, day care centers and any place where space is at a premium. Six major

play events are blended into this appealing and challenging high tech PLAYPORT. Featuring a centered Junction Box and slide, the unique Spider Web Crawl complements the Ball Bath, Walk on

Water, and Air Bounce events. The one level design offers all the excitement of the taller PLAYPORTS and is one of the most attractive values in the entire line—a best buy.



MINI-PLAY I

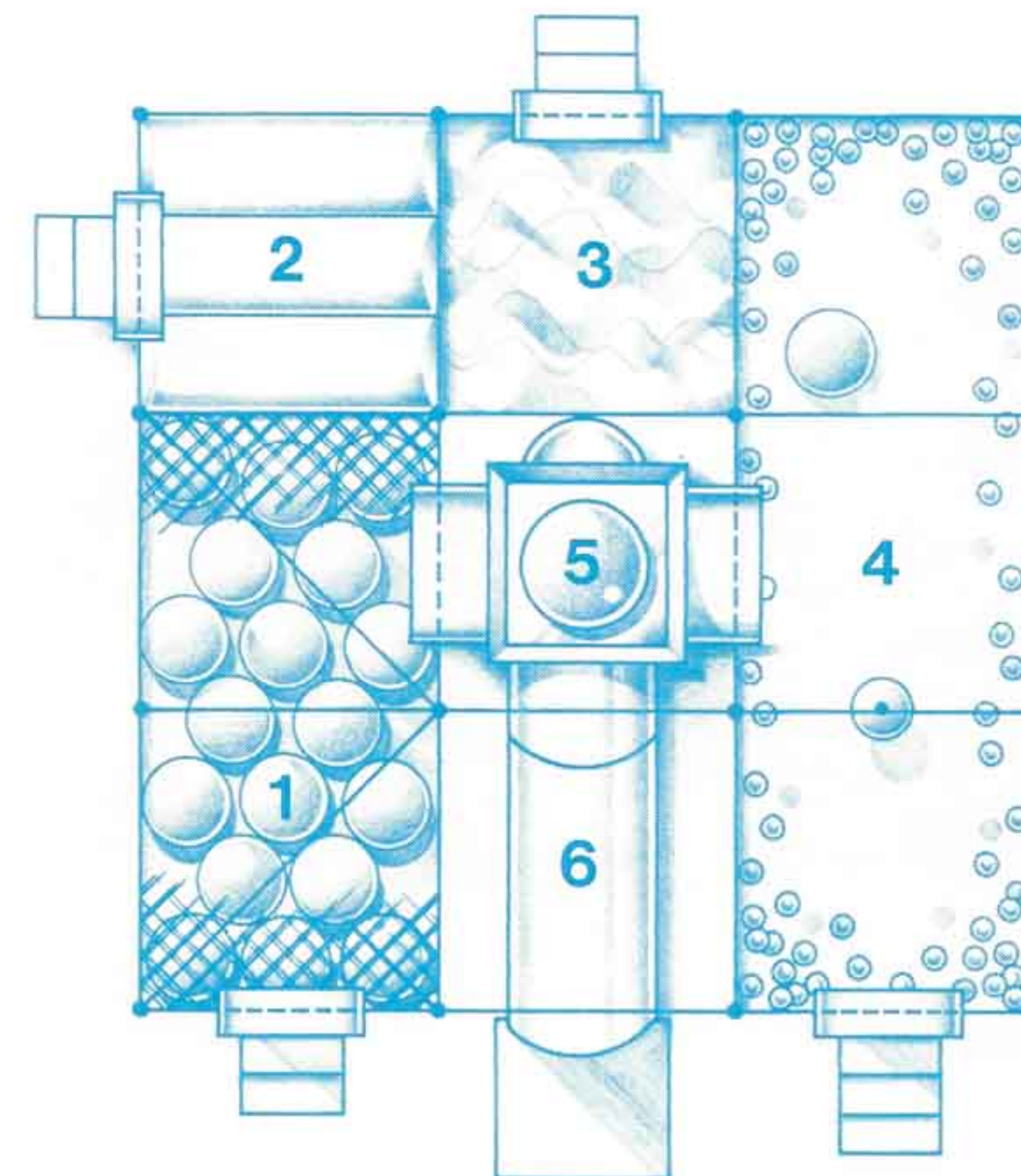

18' x 18'
Capacity 30

Prices and specifications subject to change without notice. © 1985 Pentec Design Inc.

KEY

- 1—Bubble Walk/Spider Web
- 2—Air Bounce
- 3—Walk on Water
- 4—Ball Bath
- 5—Junction Box
- 6—Super Slide

ACCESSORIES

- Ball Target
- Ball Hoop
- Big Ball
- Boppity Bag
- Kaleidoscope
- Periscope

PLAYPORT

MINI-PLAY II, III



These two mini PLAYPORTS compact the basics of soft tech play into intimate spaces. Especially designed for low ceiling indoor use, these units work beautifully outdoors. While tight bud-

gets may dictate the use of these small units, they leave nothing out of the fun department. Either mini model can be used effectively in therapy applications as well as retail stores, motel lobbies or

lawns, day care centers, or in fast food facilities. The joy and fun a child can find in a mini PLAYPORT puts everything else on the back burner. Children are loyal to PLAYPORTS regardless of size.

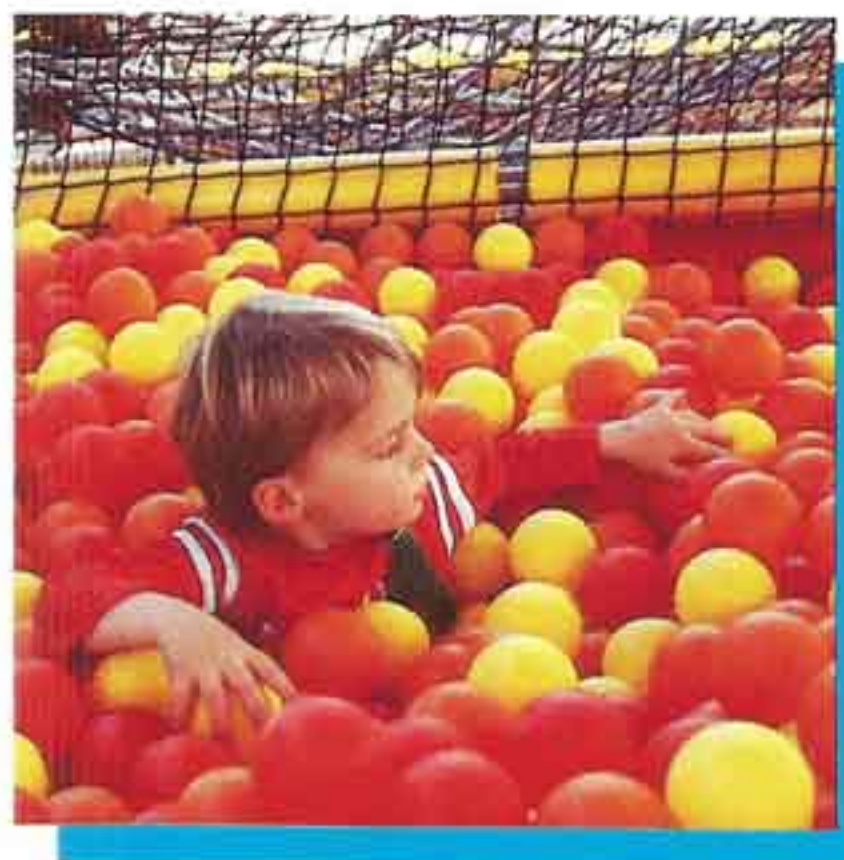

MINI-PLAY II

MINI-PLAY III

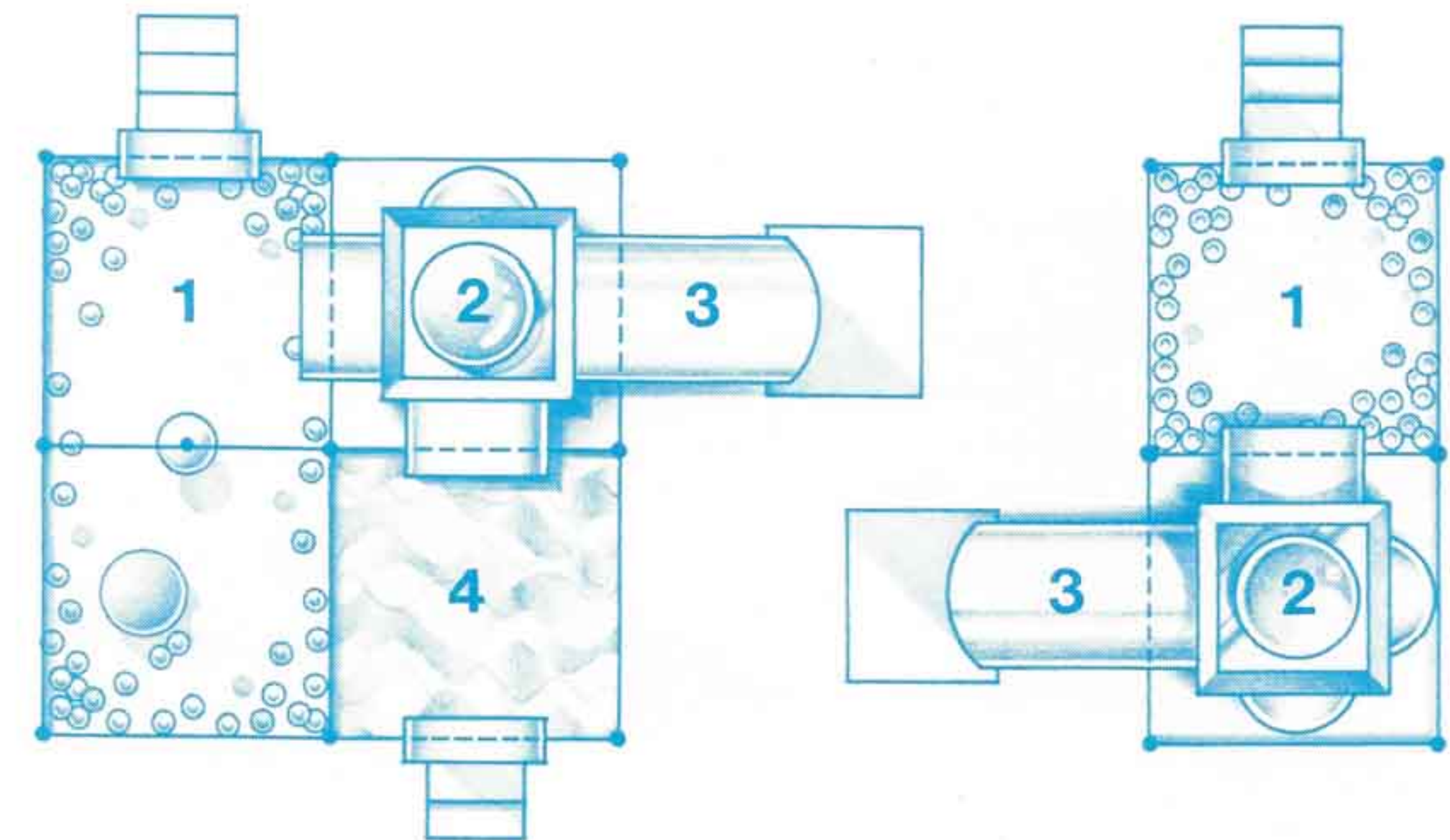

12' x 12'
Capacity 20

6' x 12'
Capacity 10

Prices and specifications subject to change without notice. © 1985 Pentec Design Inc.

KEY

- 1—Ball Bath
- 2—Junction Box
- 3—Super Slide
- 4—Walk on Water

ACCESSORIES

- Ball Target
- Ball Hoop
- Big Ball
- Kaleidoscope
- Periscope
- Boppity Bag

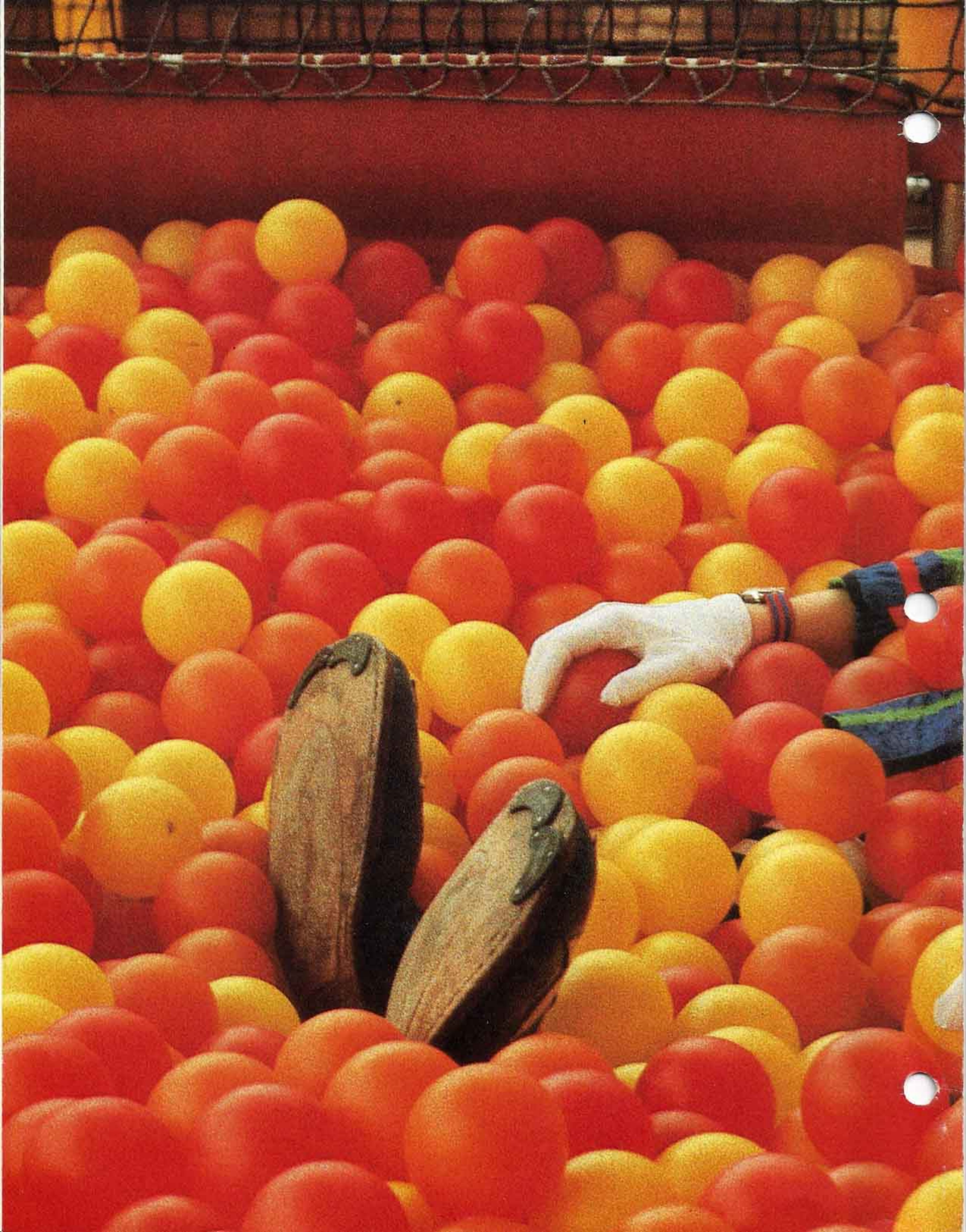

THE ORIGINALS.



ica and all over the world play in Pentes PLAYPORTS, approaching 200 different installations. These PLAYPORTS, both interior and exterior, are owned and presented by major theme and water parks, piers, adventure and picnic parks, pay-for-play operations, restaurants, fast food chains, hotels and summer camps. Studies show that both parents and children perceive PLAYPORTS as protective play environments designed to prevent the mishaps common to outmoded traditional play equipment. The record proves that these perceptions are a reality. Protecting

Since the 1930's children's play equipment changed very little. The slides, swings, seesaws and climbers set in concrete, defying both destruction and fun were the standard. Some change was seen in the mostly wooden designer playgrounds beloved by architects and planners, but how much fun can a child have jumping from platform to platform? These rigid approaches are really an affront to the creative play potential inherent in children. Today there is a totally new approach to play. This captivating original modular group of play systems is 180 degrees from anything else offered. Conceived, tested and marketed by a creative, innovative design firm, these state-of-the-art systems have created a sensation everywhere they have appeared.

Soft high-tech play components in affordable composite configurations were originated and introduced to amusement, recreation and food industries by Pentes Design in 1983. PLAYPORT received the First Place, Edward L. Schott, trophy for "the most meritorious exhibit" of equipment displayed at the annual convention of the International Association of Amusement Parks and Attractions that same year. These compacted creative play systems evolved from numerous theme park high-tech play center installations originated by the Pentes group in 1981 for Marineland in Florida, Six Flags parks and others. Annually it is estimated that over 15 million children from Amer-

...the Pentes group has developed enticing play events that both excite and capture the child's imagination while creating challenging physical tasks.

children from harm while playing was a major design criteria in the process of planning PLAYPORTS; however, a broader concept centering on the creative play experience was of equal concern. To design for children you must be



able to see things through the eyes of a child. Pentes has produced scores of delightful children's projects over more than three decades. The ability to reach children by design, coupled with hundreds of hours collectively spent observing their play, as well as a genuine love for them, has produced results. Children love PLAYPORTS.

Children are really professional players, this is their prime activity. Play is directly coupled to the learning process. Physical development is also a part of the play process. Understanding this, the Pentes group has developed enticing play events that both excite and capture the child's imagination while creating challenging physical tasks. The most rewarding part of it all is that it is fun. PLAYPORTS are so much fun that it is difficult to pull a child out of one. Parents constantly ask "how do we get them to stop?" It is difficult for a child enthralled with an environment created to envelop both their body and mind, in ways that they alone control, to even think about leaving.

The effect of the bright yellow Junction Box with its snuggie bubbles, talking tubes, a kaleidoscope or periscope and soft floor high off the ground, really becomes the treehouse that has never existed for today's metropolitan child. The Ball Bath, a dry swimming event with the feel and sound of thousands of hollow balls responding to every movement, is simply a thrill to be exploited for all possible variations by any child

Nobody Else Thinks Like Kids The Way PLAYPORT Does...

exposed to it. Children are natural crawlers and climbers. PLAYPORTS make sure they can do this with the Cargo Climb and Web Tubes while leading them from one adventure to another. The jumping urge is absorbed by the Air Bounce while the trouncing effect is satisfied by the Walk on Water. Aggressiveness is absorbed by swinging at Bop-pity Bags. A cool enclosed Slide is like going down the escape hatch of a rocket-ship. Operating a Flying Turtle roller racer puts a child "in charge." By moving the handlebars left-to-right they are propelled and rotated only one inch from the floor. Combining these play events into one unitized space frame creates a delightful fantasy effect that says to children "this is your turf." They know it and go for it. You find very large numbers of children doing it all in their own way in relatively small spaces. Eighty children can play together in a Composite III PLAYPORT in less than a thousand square feet and nobody falls out. This would require an acre of ground using common municipal play equipment. PLAYPORTS are very social. They become that way because of their compactness and the children work things out among themselves. This may

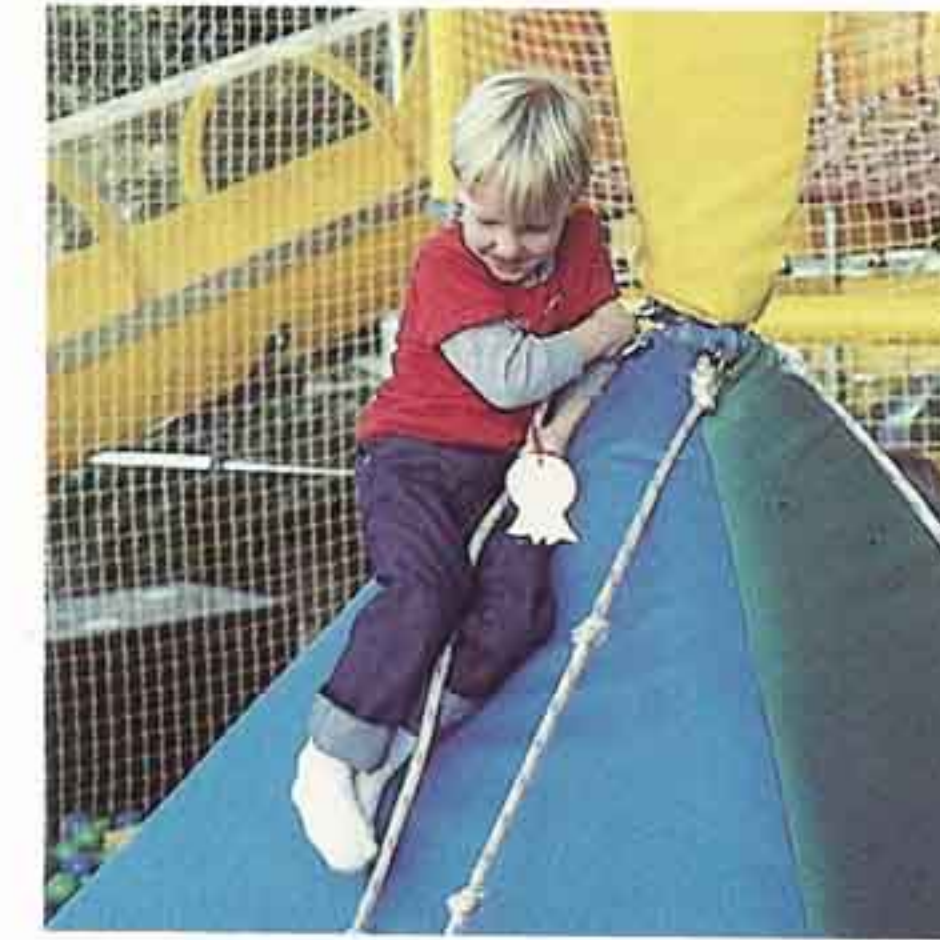

...they always demand return visits to "that PLAYPORT place" as they want to experience all its sensations over and over again.

be the reason PLAYPORTS have been so well received in Bangkok, Jakarta and Tokyo; places where space is at a premium. While the restraint netting holds it all together and the children play "in" rather than on, they always demand return visits to "that PLAYPORT place" as they want to experience all its sensations over and over again.

PLAYPORT purchasers are offered the option of installing their units with the guidance of a detailed assembly manual or by using the services of skilled supervisors or installers. PLAYPORT provides manuals on operations,

cleaning and maintenance, repairs and replacements. We know parts of PLAYPORTS are going to wear out and need replacing because they are used so heavily. Pentes offers full-service contracts for certain installations planned to keep a PLAYPORT in like-new condition with parts replacement provided and installed for a reasonable monthly fee. Service is provided by a trained local service representative, supplied with the latest service bulletins and PLAYPORT factory parts. Those wishing to maintain their own units receive the same manuals, bulletins and parts availability. PLAYPORTS are very profitable to those using them as pay-for-play facilities. Whether they are presented for profit, or therapy, as attractions or just plain fun, PLAYPORTS are a joy for the adults (yes, adults can use PLAYPORTS) and children who experience them.

PLAYPORT is an original; nothing else is quite the same. When the hot new play adventures appear you can be sure you will find them in a PLAYPORT. We are working on them right now. The imitators will never catch up to PLAYPORT because nobody else thinks like kids the way we do.

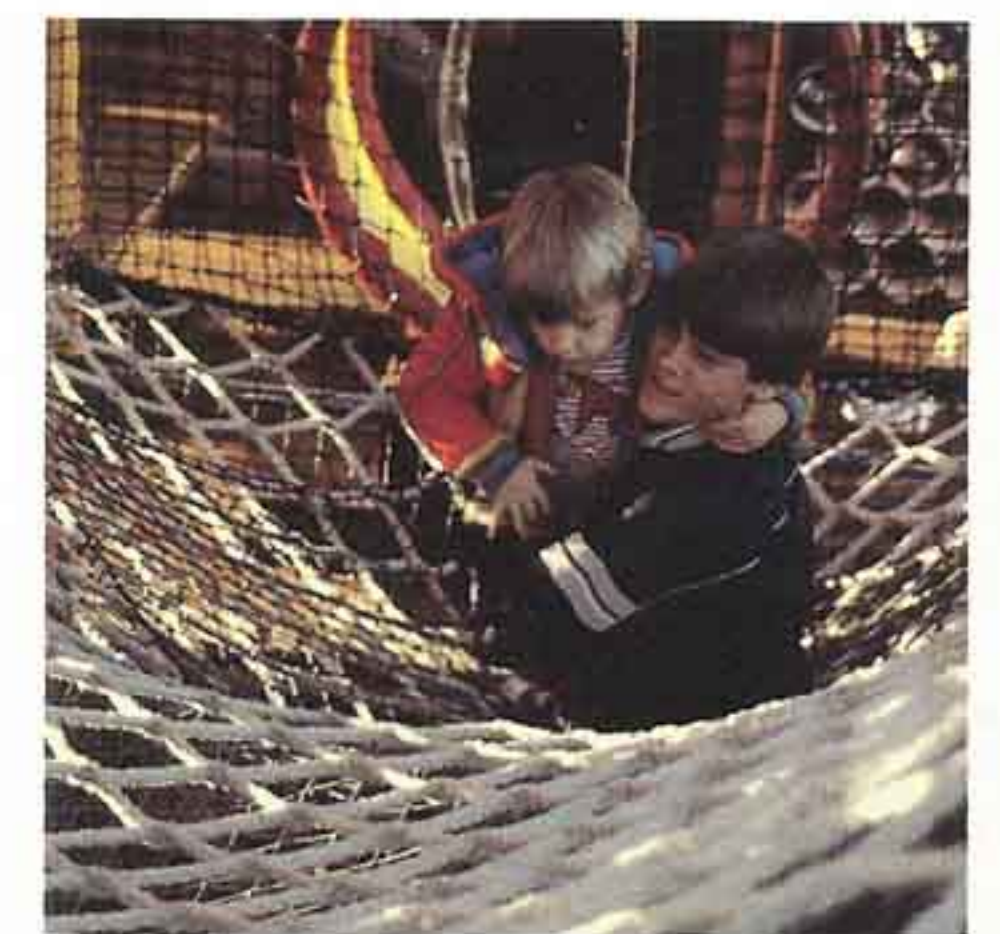

© Pentes Design Inc.

PLAYPORT

PENTES DESIGN INC. • 1346 Hill Road • Charlotte, North Carolina 28210 • (704) 552-5400

PLAYPORT

COMPOSITE I



The smallest of the PLAYPORT Composite Line is big on play value. This 18' x 18' compact Composite is just the unit to use where space is a problem. Controlled access provides a continu-

ous cycle of fun for up to 30 kids. All activity centers in a 12' x 12' Ball Bath where kids "swim" through a pool of 17,000 hollow plastic balls. Additional activities include Bubble Mountain, a Junc-

tion Box and Super Slide. The most economical of all composites, this unit is a real kid pleaser! It works equally well indoors or out and is available with optional sun screens.

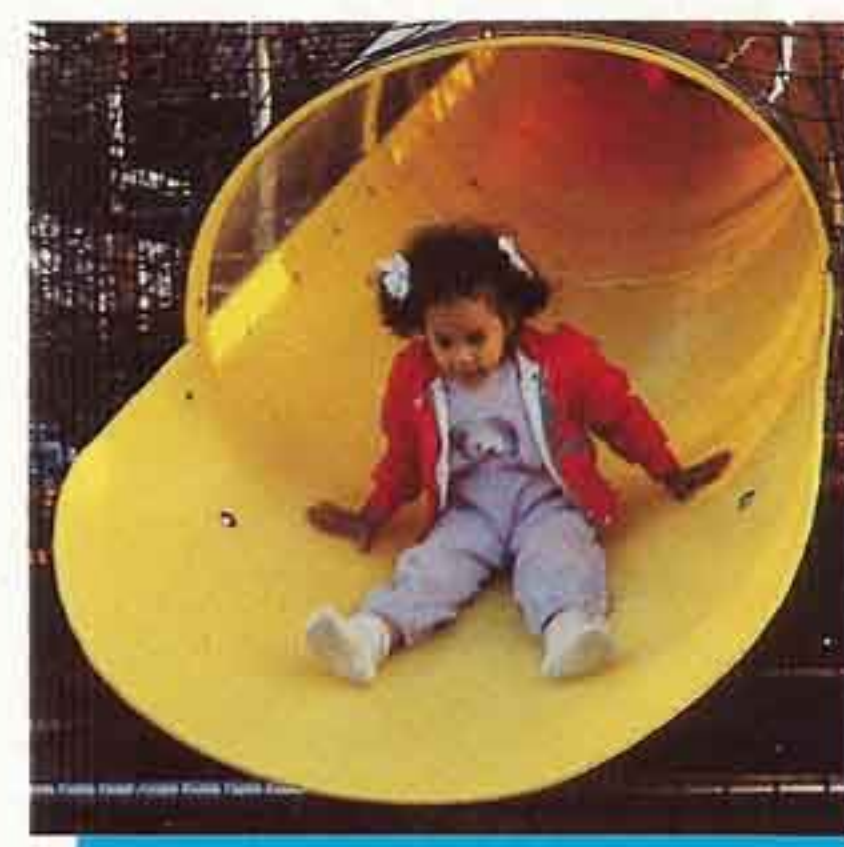
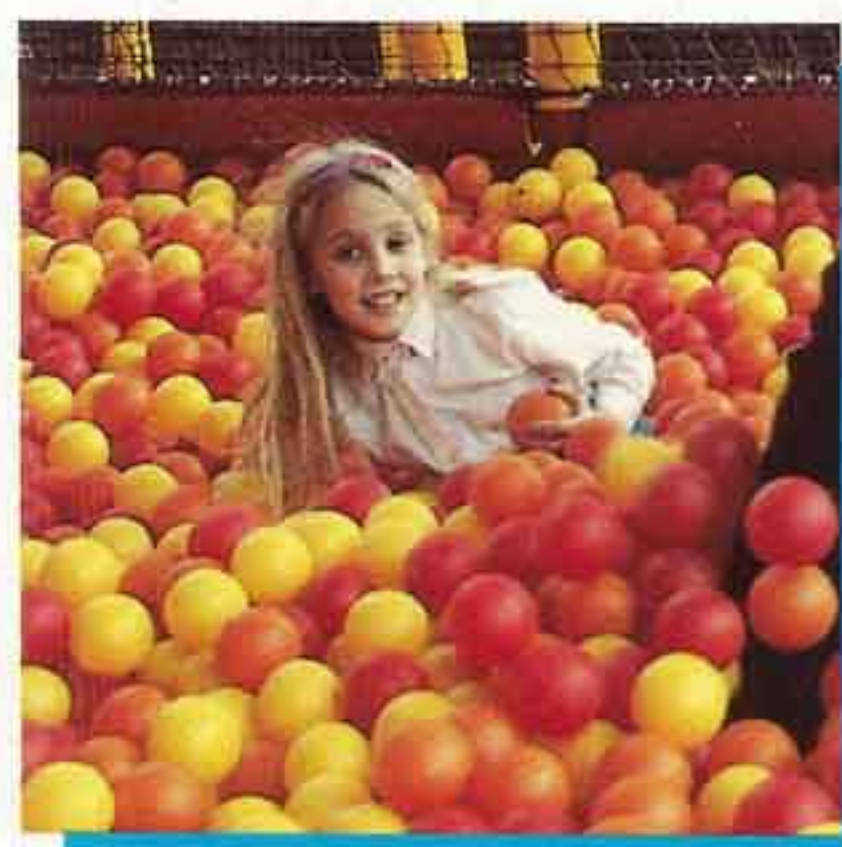
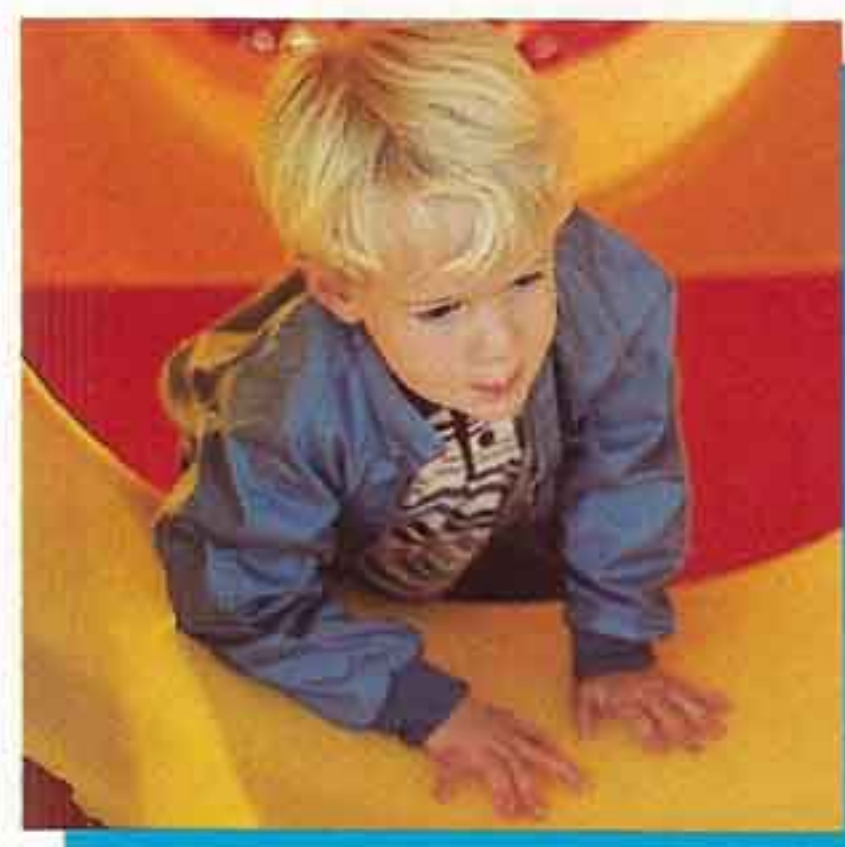

COMPOSITE I

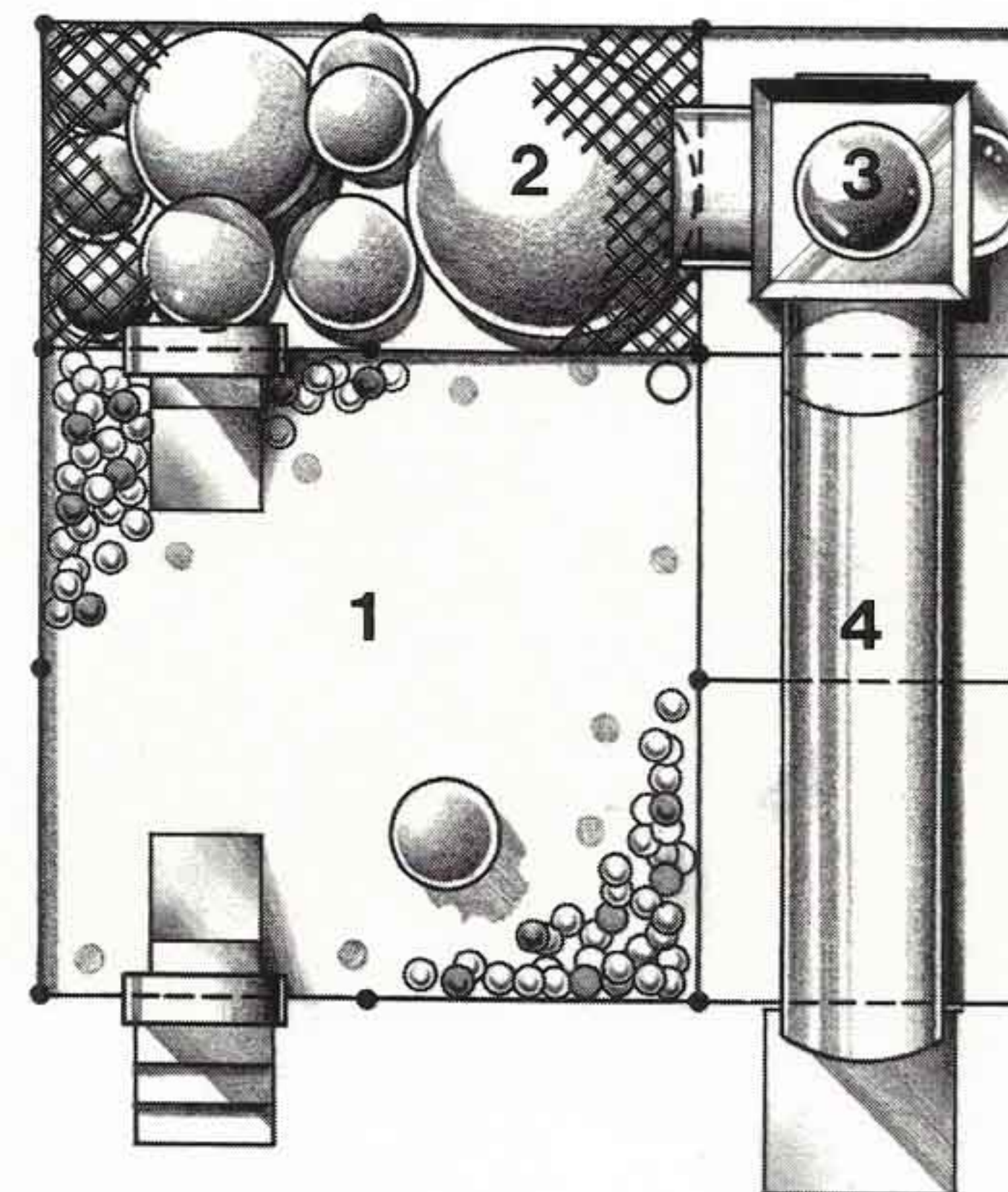

18' x 18'
Capacity 31

Prices and specifications subject to change without notice. ©1985 Pentec Design Inc.

KEY

- 1—Ball Bath
- 2—Bubble Mountain
- 3—Junction Box
- 4—Super Slide

ACCESSORIES

- Ball Target
- Ball Hoop
- Big Ball
- Periscope
- Kaleidoscope

PLAYPORT

COMPOSITE II



The most popular sized Composite II easily fits into a variety of spaces. Up to 45 kids find a number of different play activities in this controlled access Composite. A Web Crawl provides unique entry into a

12' x 12' Ball Bath with Boppity Bags. Accessible only from the central Ball Bath, other play elements include a Tube Loop, Bubble Mountain, Junction Box passages and Cargo Net with exit through

the enclosed Super Slide. For use indoors or out, this unit is available with optional sun screens. Composite II, the most popular mid-sized unit features good capacity with a wide range of activities.

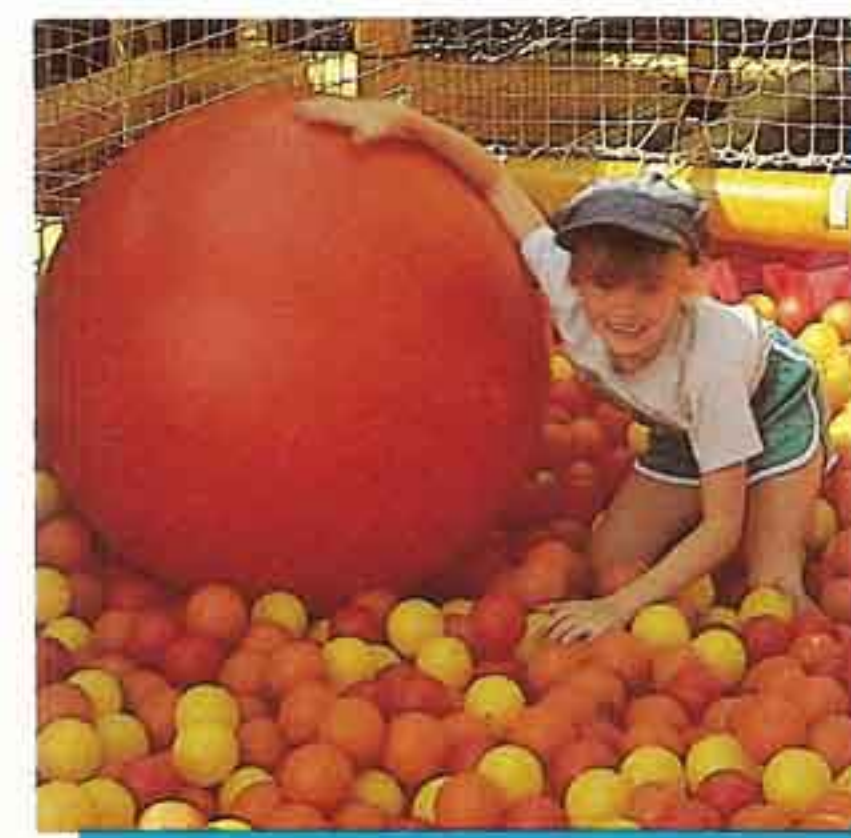

COMPOSITE II

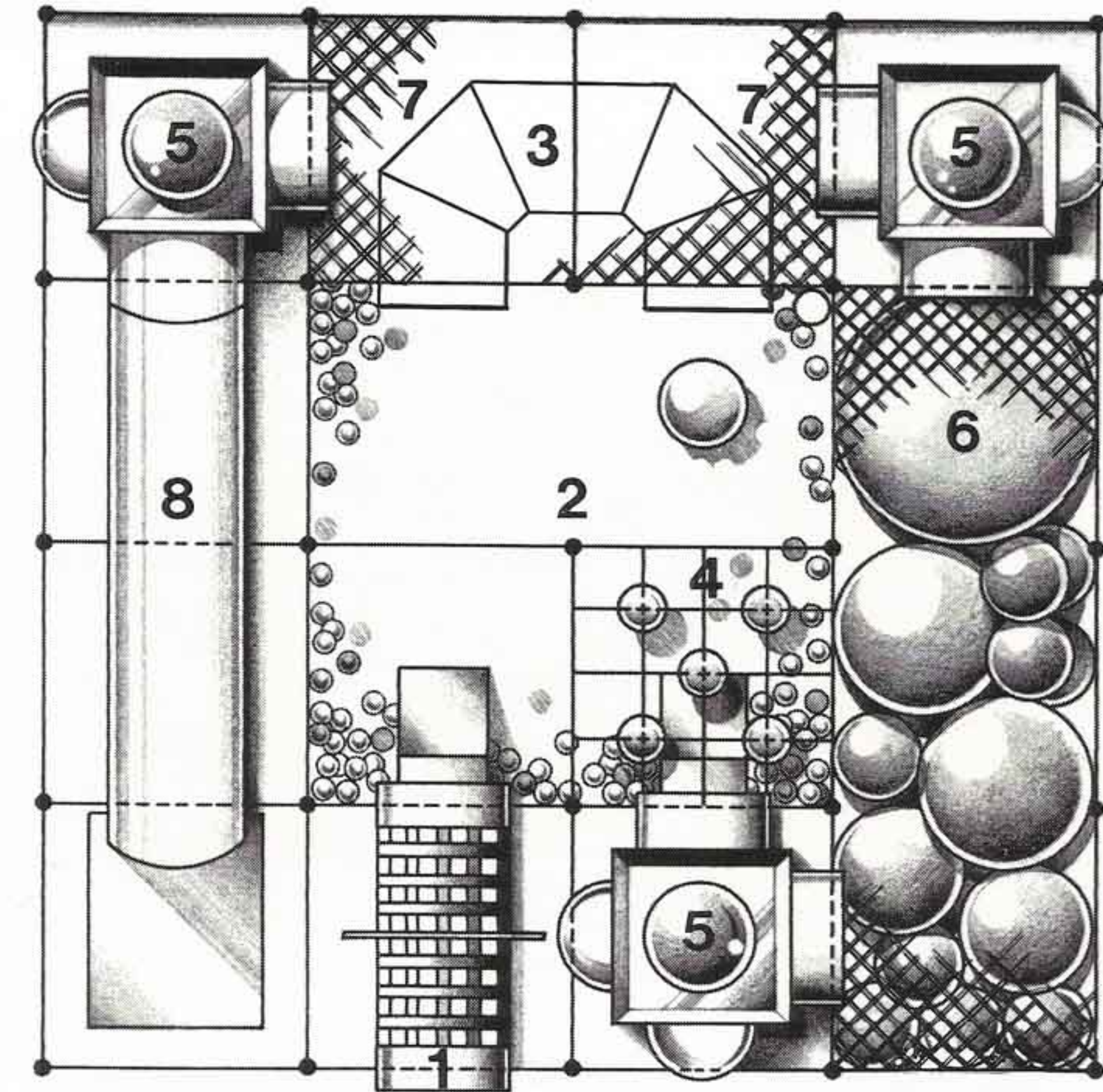

24' x 24'
Capacity 45

Prices and specifications subject to change without notice. ©1985 Pentes Design Inc.

KEY

- 1—Web Crawl
- 2—Ball Bath
- 3—Tube Loop
- 4—Boppity Bags
- 5—Junction Box
- 6—Bubble Mountain
- 7—Cargo Climb
- 8—Super Slide

ACCESSORIES

- Ball Target
- Ball Hoop
- Big Ball
- Kaleidoscope
- Periscope
- Talking Tube

PLAYPORT

COMPOSITE III



The best selling Composite III in use all over the world in theme parks, shopping centers, piers and pay-for-play facilities, plays up to eighty children in under 1000 square feet. Featuring the King of

the Mountain, rated as the all time favorite by its users, this unit offers the best range and mix of play elements ever combined into one PLAYPORT. The Composite III is available in a special adult

model featuring dramatic colors and finishes for sophisticated players who are still kids at heart. Modified models are available featuring "add-ons" to increase fun and capacity.

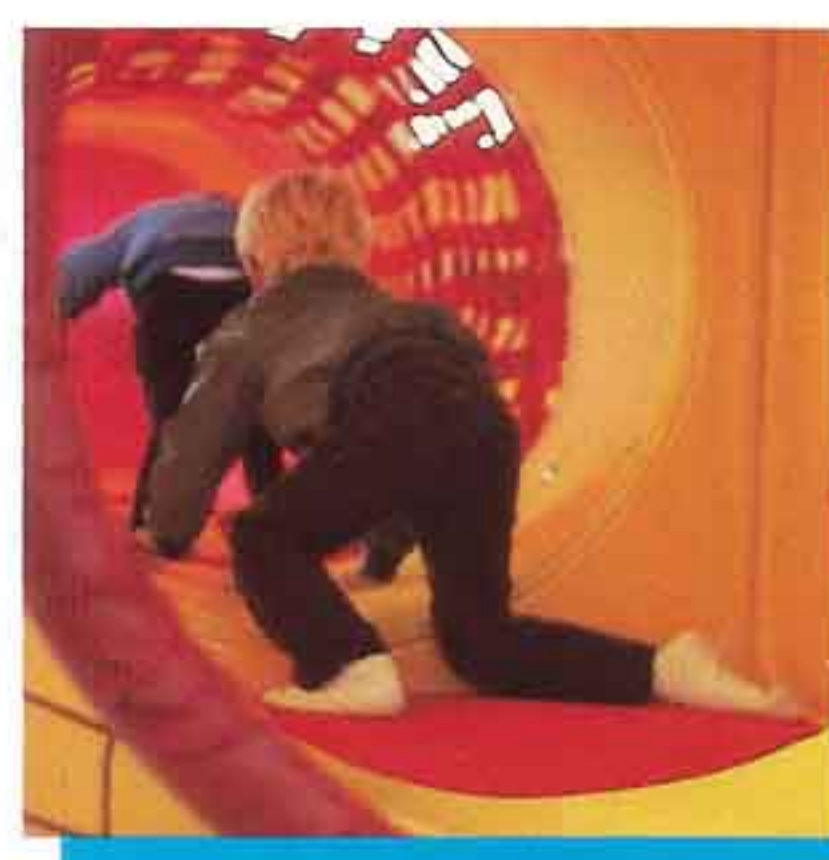
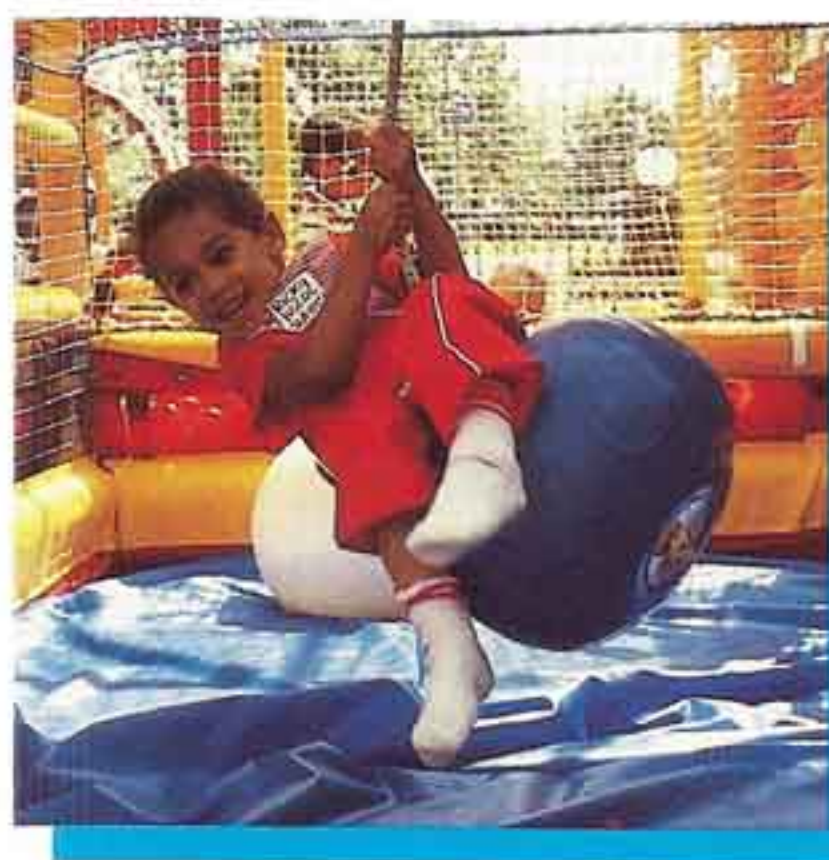

COMPOSITE III

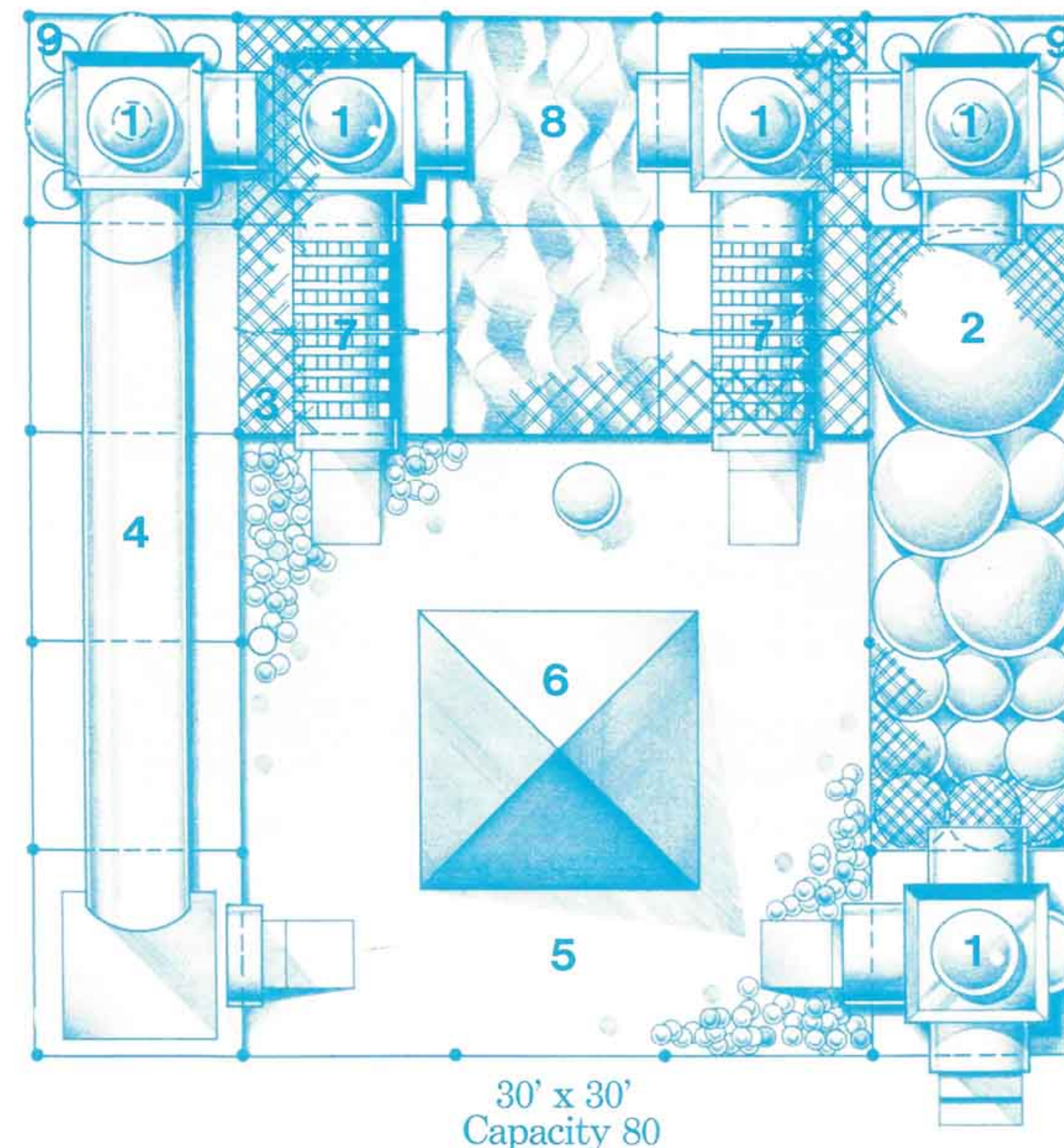

Prices and specifications subject to change without notice. © 1985 Pentes Design Inc.

KEY

- 1—Junction Box
- 2—Bubble Mountain
- 3—Cargo Climb
- 4—Super Slide
- 5—Ball Bath
- 6—King of the Mountain

- 7—Web Crawl
- 8—Walk on Water
- 9—Bobbity Bags

ACCESSORIES

- Ball Target
- Ball Hoop
- Big Ball
- Kaleidoscope
- Periscope
- Talking Tube

PLAYPORT

PLAY PITS

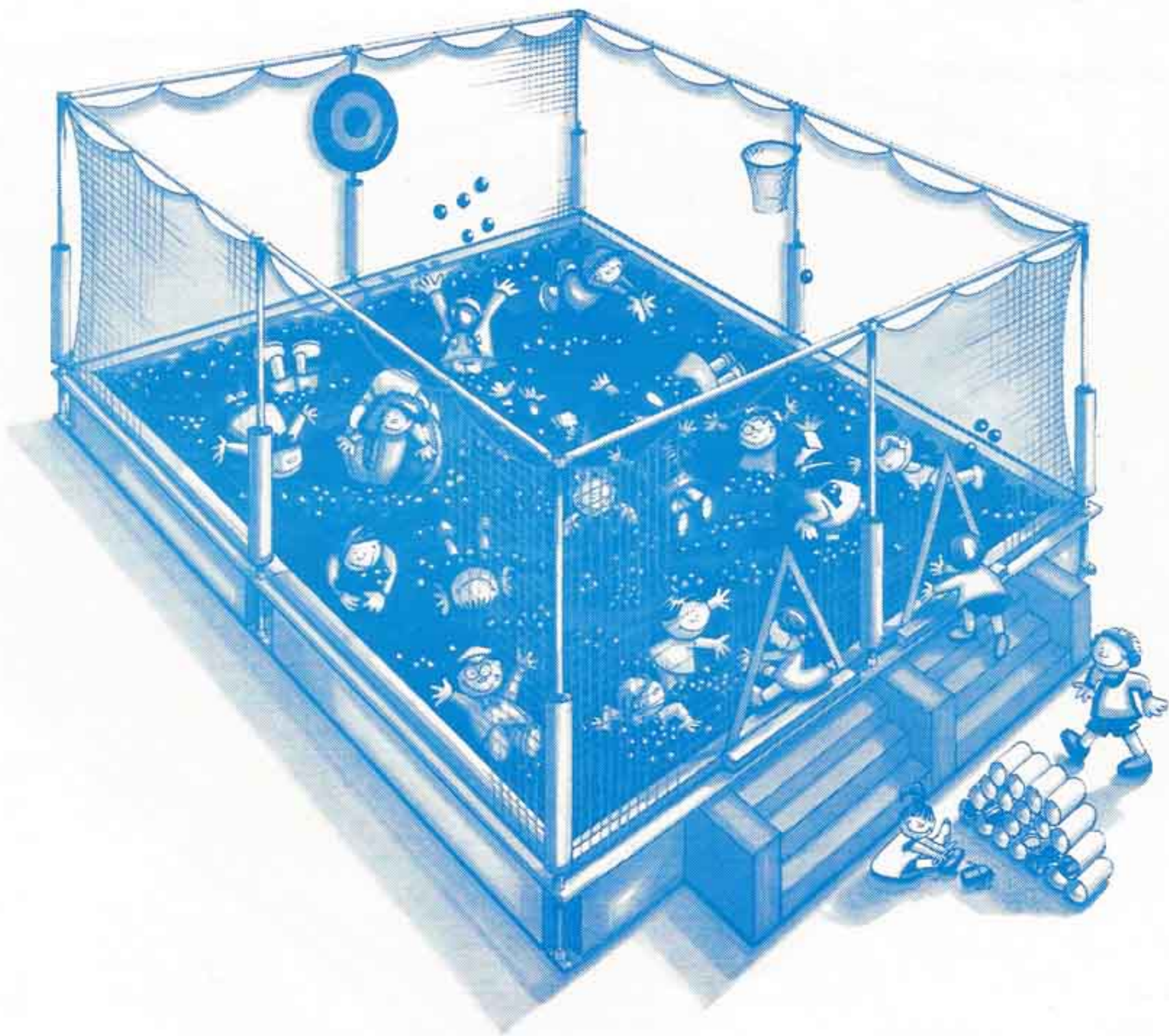

The play event that started a revolution. There are more PLAYPORT Ball Bath installations around the world than all the other makes put together. Kids can swim, wallow, roll and dive into thousands of colorful balls contained in the original "floating pit." Air supported, fully padded, netted, soft and tough long lasting materials make this the best play value available. They are complete with entry/exit ramps, shoe cubby, basketball hoop, target and super play ball. You get it all from PLAYPORT. Use it indoors or out. Sunscreens are available.

BALL BATH

SIZE	CAPACITY
6' x 6'	5
12' x 12'*	20
18' x 18'	45
24' x 24'	80

Larger sizes available.

*Illustration shows this unit.

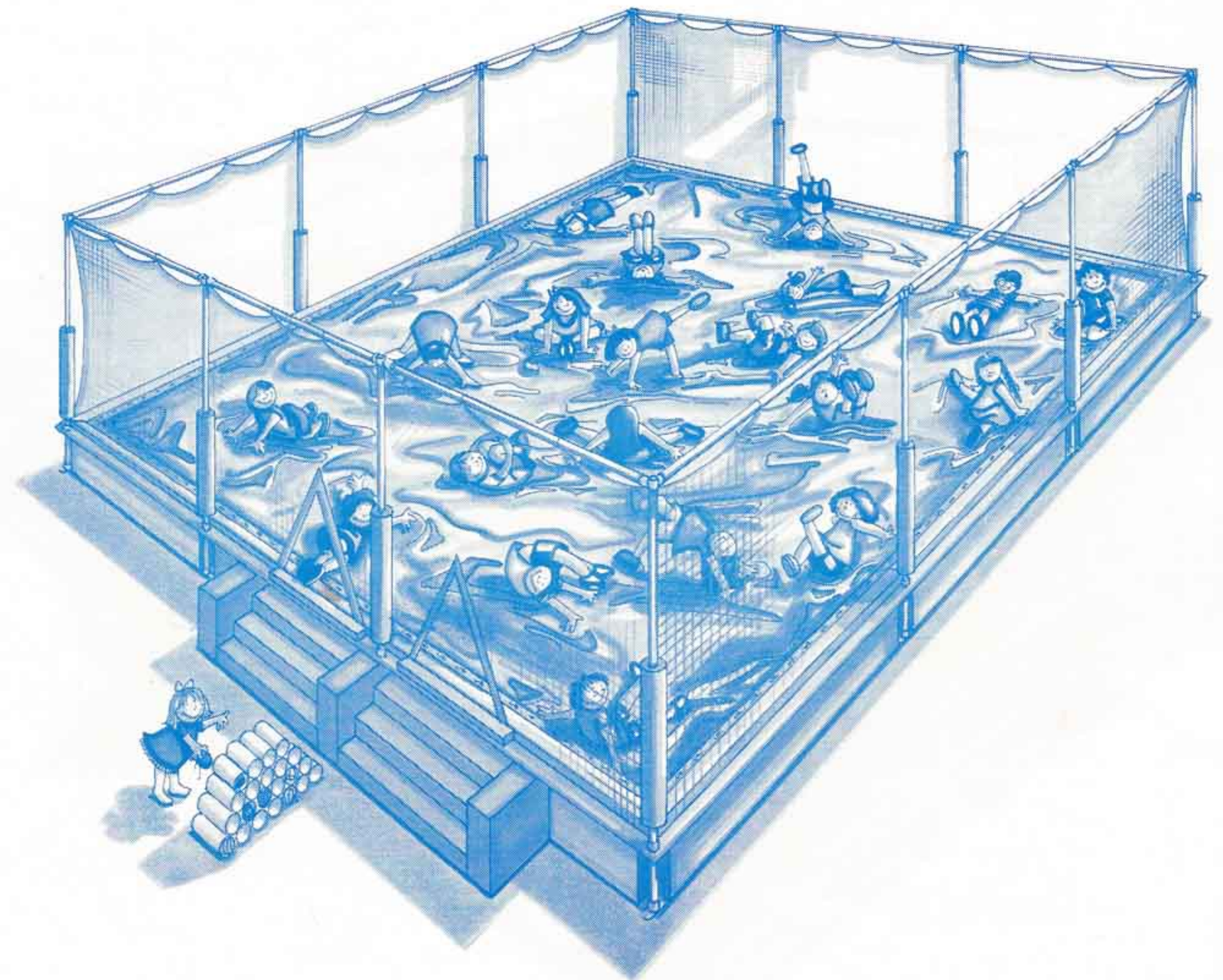

Wallow, roll, and flop on the undulating, unpredictable PLAYPORT Walk on Water. A flexible, vinyl impregnated nylon membrane covers a series of specially constructed tough urethane water mattresses to make up the various sizes of the popular play event. The modular mattresses allow this unit to be custom made in almost any size. They are supplied with padded pit liner, netting, post pads and entry exit step. A 2 ft. water filled super ball is available as an accessory. Use it indoors or out. Sunscreens are available.

WALK ON WATER

SIZE	CAPACITY
6' x 6'	3
12' x 12'	12
18' x 18'*	27

Larger sizes available.

*Illustration shows this unit.

PLAYPORT

AUTO KID WASH™

U.S. and Foreign Patents Pending.

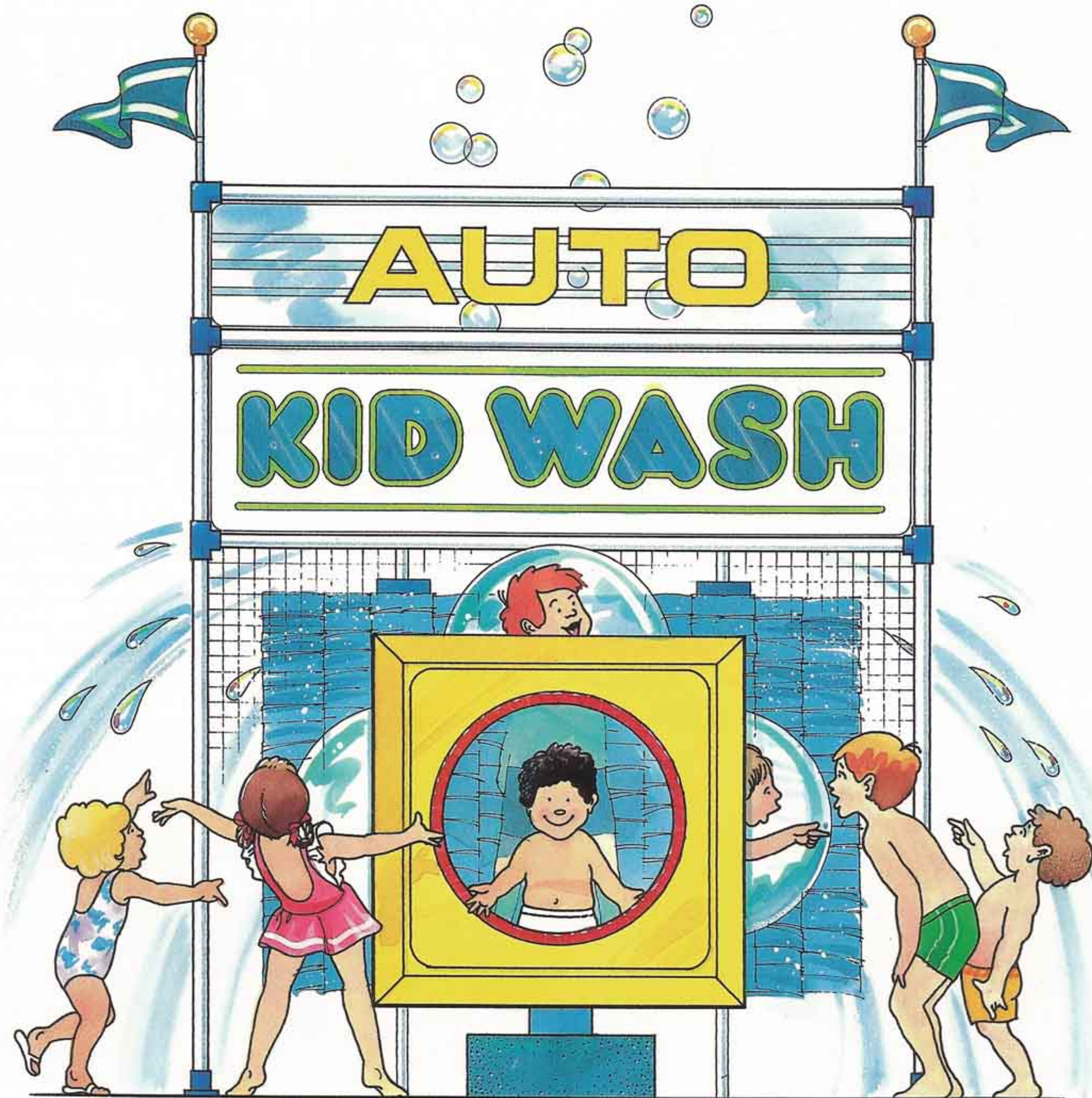

Clean Up Your Kids' Act!

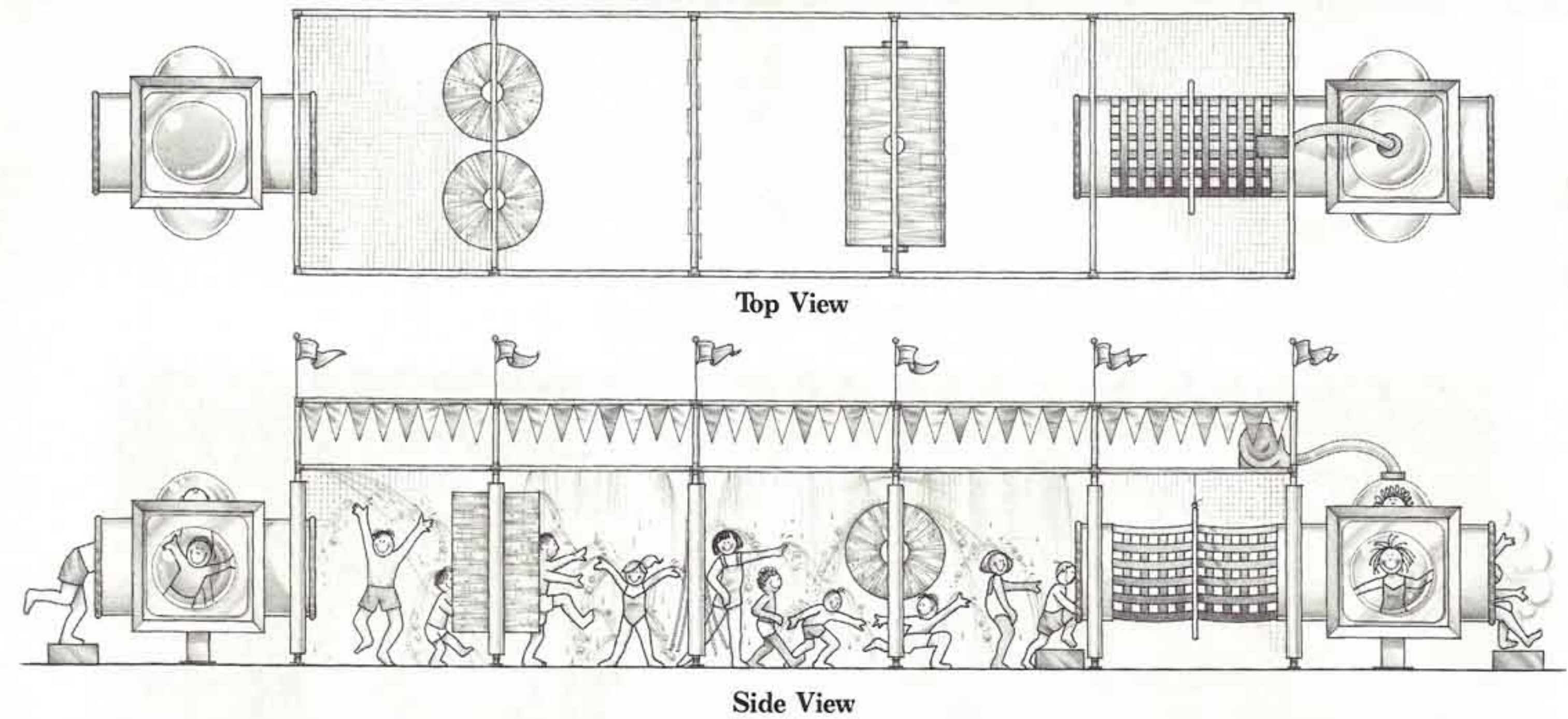

Basic Unit I

- Entry Signage
- Entry Junction Box
- Shower I
- Vertical Foam Brushes
- Shower II
- Vertical Foam Scrubbers
- Shower III
- Horizontal Brush
- Water Wheel Propeller
- Shower IV
- Drip Dry Web Tube
- Power Dry Blower
- Dry Room Junction Box
- Soft Floor Mat
- Shower Pipe System
- Pole Flags
- Pennant Flag Strings

Prices and specifications subject to change without notice.

Self-Contained Unit II

All Basic Items Plus:

- Wood Slat Floor
- Filter System
- Recirculating Pump
- Vinyl Pool Envelope
- Chlorinator
- Valve Box

Accessories

- Side Blowers
- Side Signage
- Vertical Sprays
- Automatic Timer Sprays
- Additional Sponge Bars
- Outside Border Mats
- Top Border Lighting (12 volt)
- Periscope
- Fog Machine

Either Auto Kid Wash Model requires a foot print of eight feet wide by forty-two feet long. A six foot clearance around the entire unit will require a space twenty feet by fifty-four feet. It is recommended that accessory border mats be used outside the unit. They will absorb falls that might occur when children are in transit around the Auto Kid Wash.

©1986 Pentec Design, Inc.

PENTES DESIGN INC.

1346 Hill Road • Charlotte, North Carolina 28210 • (704) 552-5400

It Looks Like and Works Like a Car Wash but It Washes Kids!

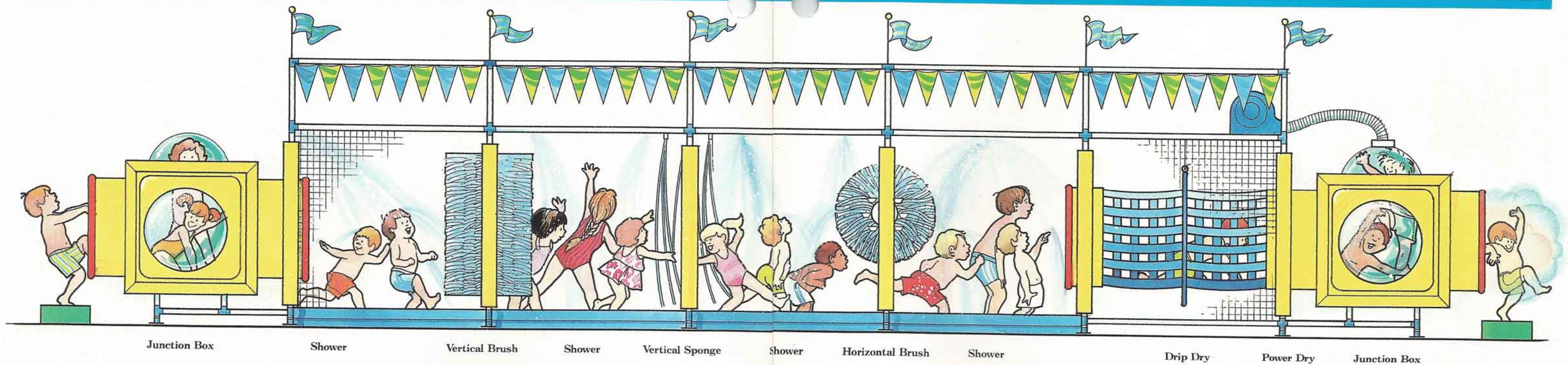

AUTO KID WASH™

Have you ever wondered what it would be like to run through an automatic car wash while everything was running? For an adult it may be a fantasy, but for children the Auto Kid Wash is now a reality. Designed to the same proportions and sequence as an actual car wash, the Auto Kid Wash actually washes kids instead of cars. The modular steel frame supports the foam brushes, scrubbers, and the staged water sys-

tem ending with a final mist. The blower powered dryer at the end is the climax to this clever water attraction. The kids love it, and the parents all wish they had one at home in the backyard. The Auto Kid Wash is supplied with a complete assembly manual and comprehensive operational guidelines. Expert assembly supervision is available at additional cost.

Basic and Self-Contained Units

The Auto Kid Wash comes in two models. The basic Unit I can be installed on a drainable pad or shallow pool adjacent to an existing pool. The water system is supplied from the existing pool by a pump furnished and installed by the buyer. The water is drained into and recycled through the pool's existing filter and treatment system. This is the most economical method of installation. The self contained Unit II has

a built-in water reservoir recycling through built-in pumps, filter, and treatment system. Both units are completely surrounded with nylon restraint netting and have a soft impact absorbent floor. The horizontal foam brush is in constant motion, and the kids supply the power for the vertical brushes and scrubbers. The self-contained feature allows installation on any clean level surface.

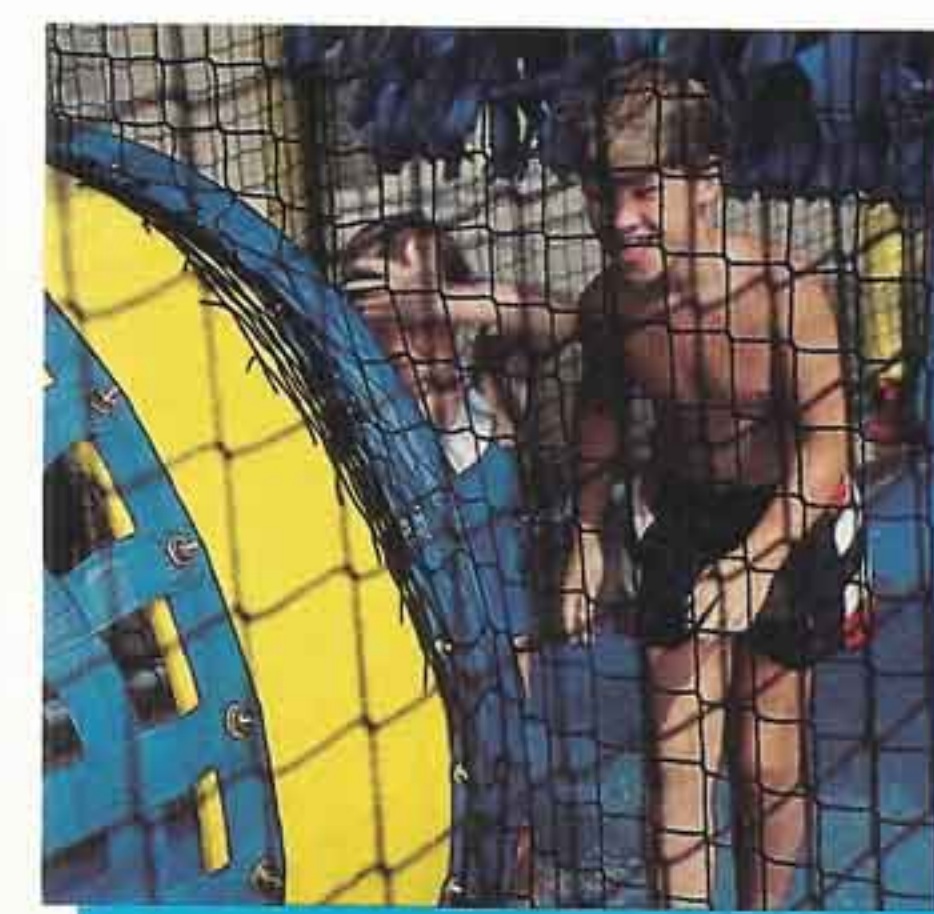
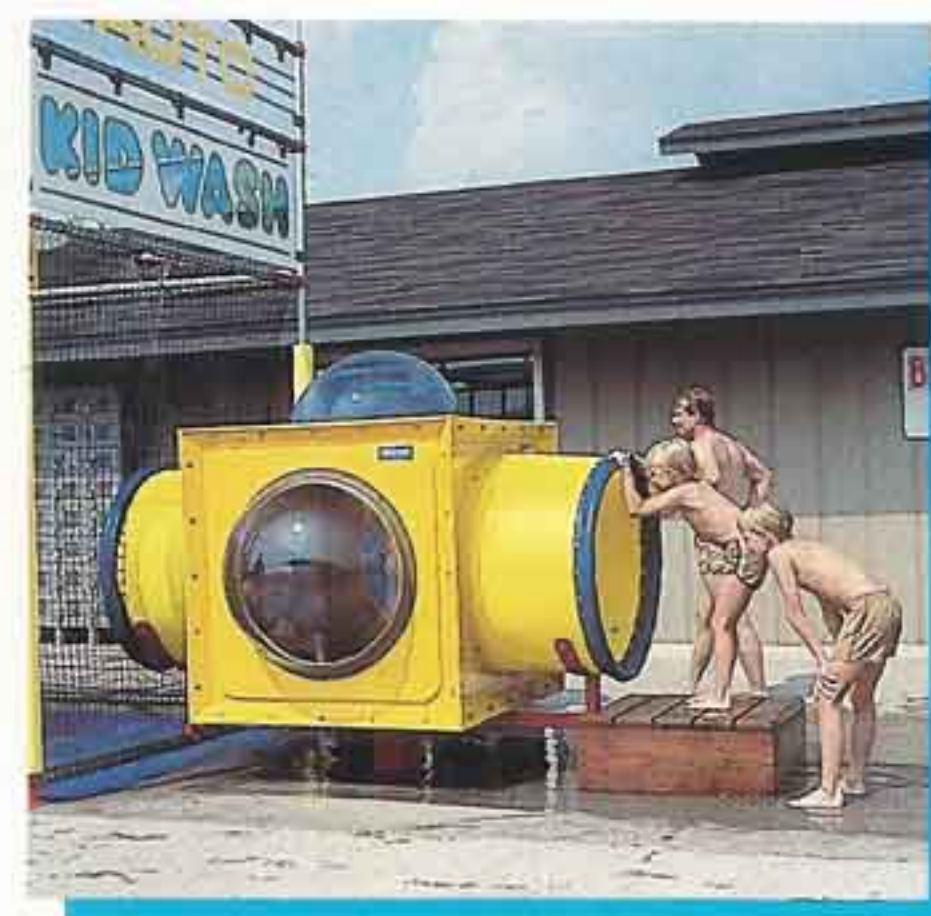

See it on video tape—\$25.00 Postage Paid, refundable upon return.

PLAYPORT

©1986 Pentec Design, Inc.
PENTES DESIGN INC.
 1346 Hill Road • Charlotte, North Carolina 28210 • (704) 552-5400

PLAYPORT

RAINMAZE II



The PLAYPORT Rainmaze II brings a new level of excitement into the wading pool. Uniquely created for water parks, this "wet" unit is comprised of seven high-rise junction boxes with bubble

domes for viewing activity. Small visitors dart in and out of suspended Web Crawls which are continually showered by a light spray. Once passage through this ultimate hide and seek maze is accom-

plished, the child takes an exciting trip down the super slide into the pool below. Sure to make a big splash—the Rainmaze II with its continuous cycle of fun keeps children coming again and again.

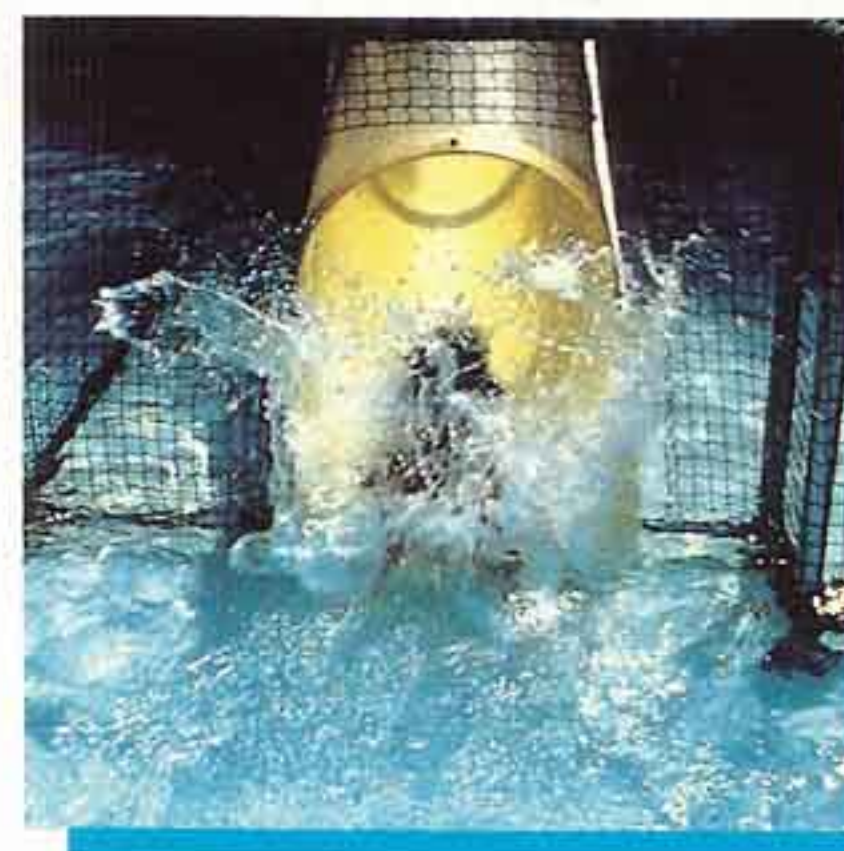

RAINMAZE II

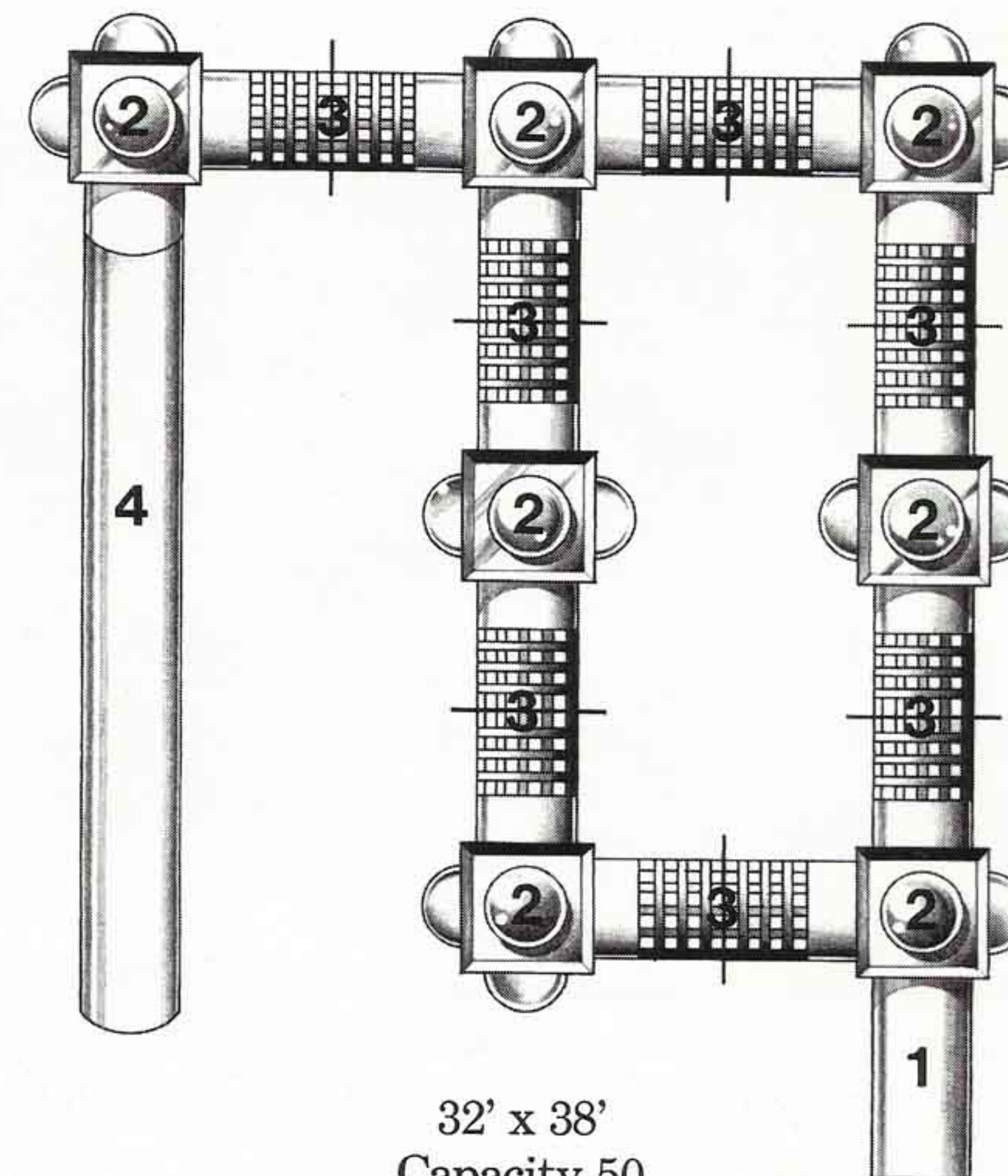

32' x 38'
Capacity 50

Prices and specifications subject to change without notice. ©1985 Pentes Design Inc.

KEY

- 1—Tube Crawl
- 2—Junction Box
- 3—Web Crawl
- 4—Super Slide

ACCESSORIES

- Talking Tube

PLAYPORT

SUPER-PLAY I FUN BOAT™

Conceptual rendering—exact unit may differ slightly.

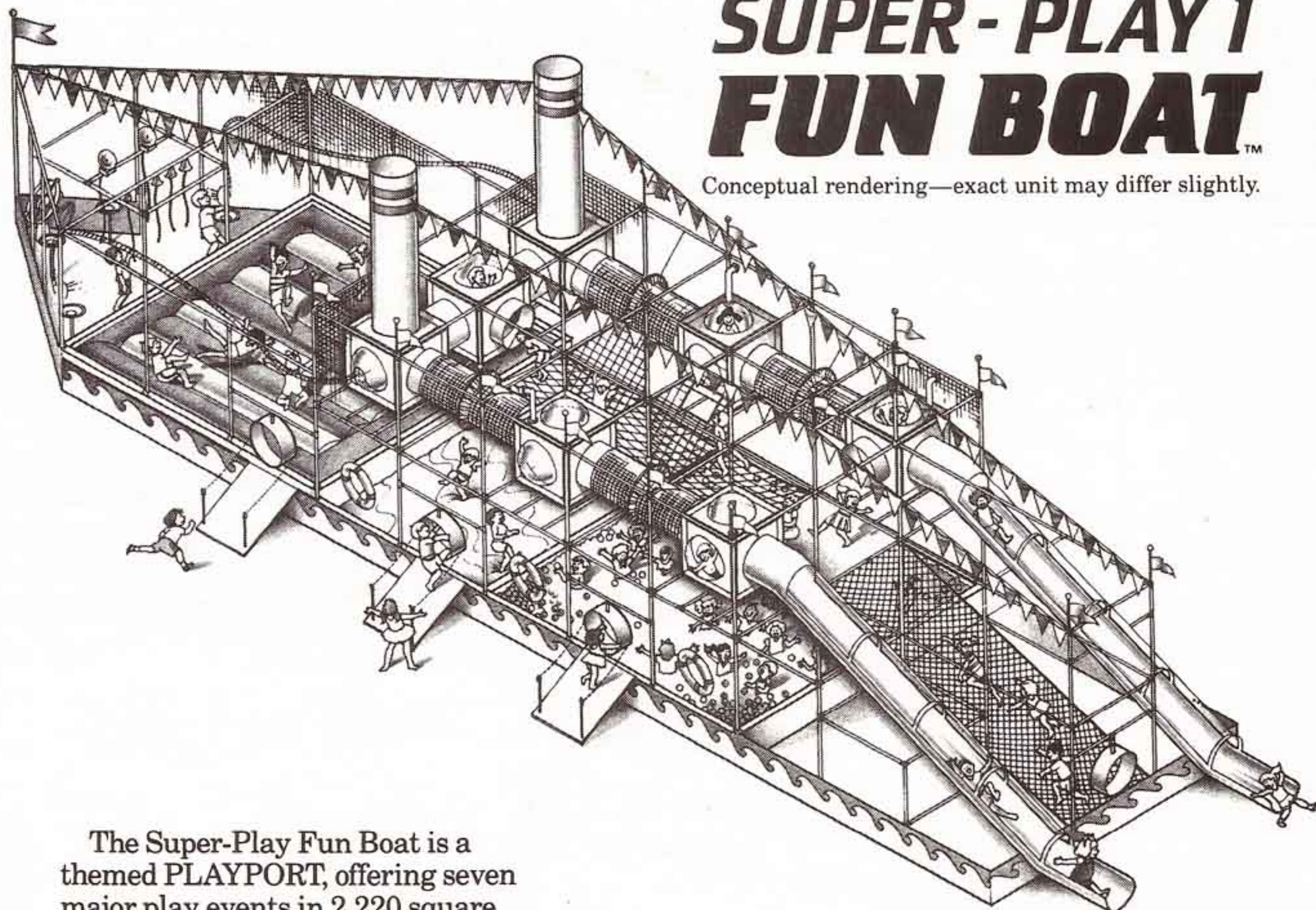

The Super-Play Fun Boat is a themed PLAYPORT, offering seven major play events in 2,220 square feet on two levels. The upper level contains a cargo climb with spider nets, a pipeline crawl, and two 24 ft. exit slides. Accessories include four periscopes and two talking tubes in the Junction Boxes. The ground level contains an 18' x 18' ball bath with boppity bags, a 12' x 18' walk on water, an 18' x 18' cloud bounce plus a bell and whistle room in the bow. Smoke stacks, wave skirting, pole flags and banners provide additional color and theming. Fun Boat will play 140 children at one time. An optional fogger is available that will produce non-toxic smoke effects from the smoke stacks and other areas.

Super-Play is the latest addition to the PLAYPORT system of soft high-tech play events. Designed for high capacity Super-Play provides the most popular field-proven, hazard-free elements in combinations that really "wow" the kids. Sized fifty to two hundred percent larger than the popular 30' x 30' Composite III, Super-Play offers an exciting "all in one" package. When you have the space and need high turnover, Super-Play is the way to go. Individual entry/exit configurations provide for controlled access and minimum monitoring personnel. © 1986 Pentec Design Inc.

SUPER-PLAY I FUN BOAT™

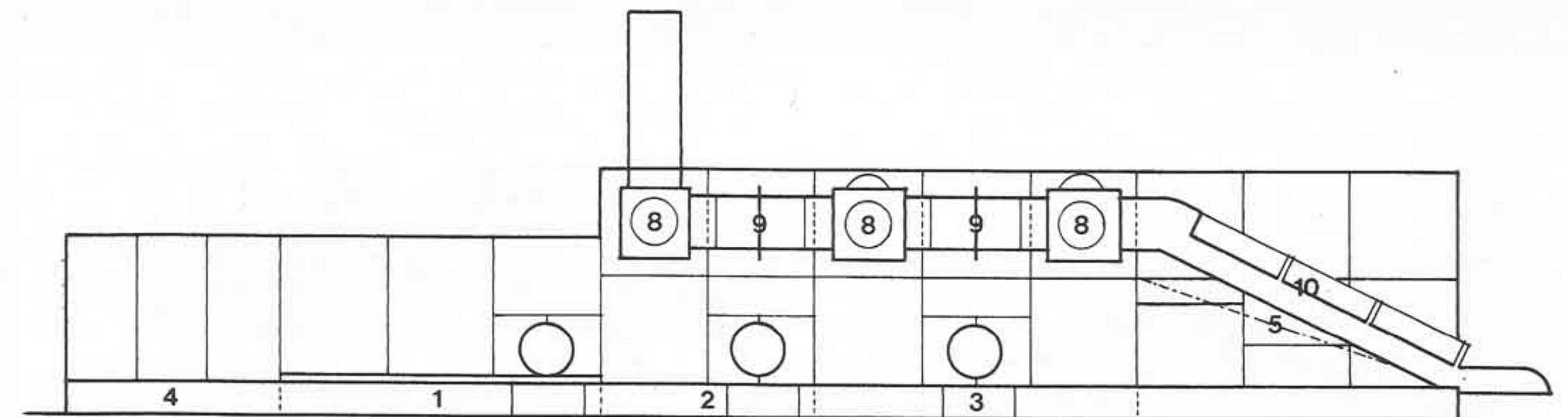

Side View

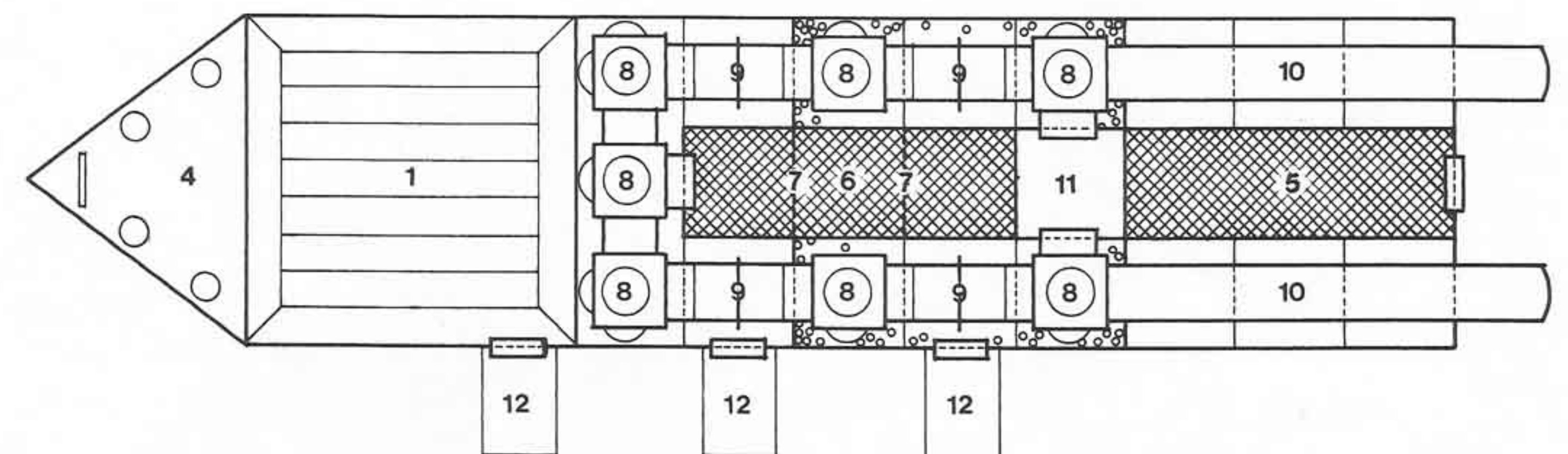

Top View

Size: 18' x 84'
Capacity: 140

KEY:

- 1 - 18' x 18' Bounce
- 2 - 12' x 18' Walk on Water
- 3 - 18' x 18' Ball Bath
- 4 - Bell and Whistle Bow
- 5 - Cargo Climb
- 6 - Cargo Crossing
- 7 - Spider Net
- 8 - Junction Box
- 9 - Web Crawl
- 10 - Super Slide
- 11 - Platform/Deck
- 12 - Entry/Exit Ramp

ACCESSORIES:

(All accessories included unless noted)

- Ball Target
- Ball Hoop
- Big Ball
- Boppity Bags
- Kaleidoscope
- Periscope
- Talking Tubes
- Ship Wheels
- Ship Bells
- Fog Machines (optional)

THEMING:

- Smoke Stacks
- Pole Flags
- Banners/Pennants
- Wave Skirting

PLAYPORT

SUPER-PLAY II™

Conceptual rendering—exact unit may differ slightly.

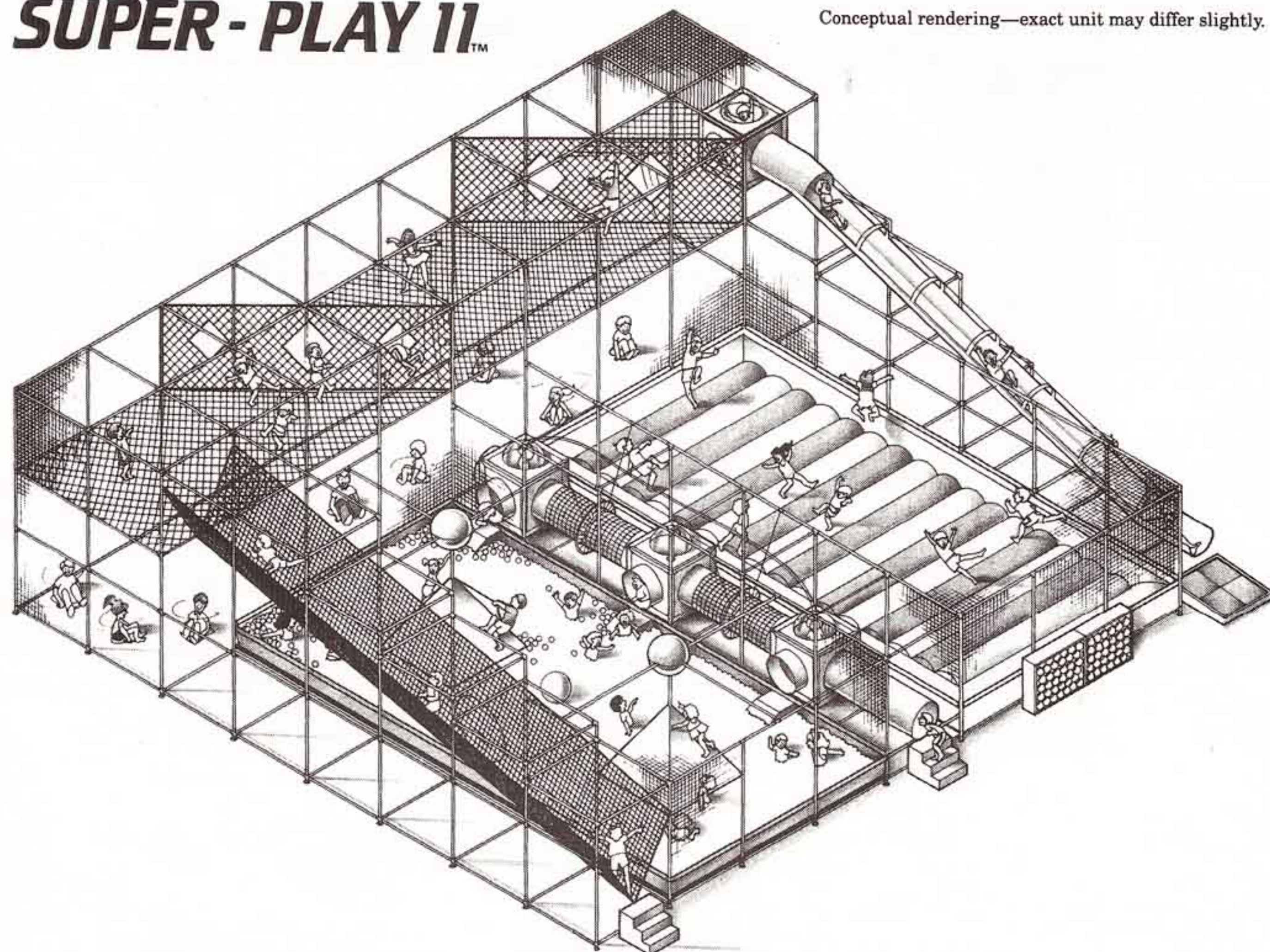

The Super Play II offers 8 major play events in 3,240 square feet on two levels. Access to the upper level is through a "V" Rope Bridge. The upper level contains a Cargo Climb with four 6' x 17' Spider Nets and a Super-Slide exit. The ground level includes an 18' x 36' Ball Bath and an 18' x 36' Cloud Bounce. Access to either of these areas is gained through a Pipeline Crawl with Periscope and Tube Phone. Entry to the Turtle Track with 42 Flying Turtles is also accessible through the Pipeline Crawl. All play elements are supersized to offer exceptional high-capacity play.

Super-Play is the latest addition to the PLAYPORT system of soft high-tech play events. Designed for high capacity Super-Play provides the most popular field-proven, hazard free elements in combinations that really "wow" the kids. Sized fifty to two hundred percent larger than the popular 30' x 30' Composite III, Super-Play offers an exciting "all in one" package. When you have the space and need high turnover, Super Play is the way to go. Individual entry/exit configurations provide for controlled access and minimum monitoring personnel.

© 1986 Pentec Design Inc.

PENTES DESIGN INC. • 1346 Hill Road • Charlotte, North Carolina 28210 • (704) 552-5400

SUPER-PLAY II™

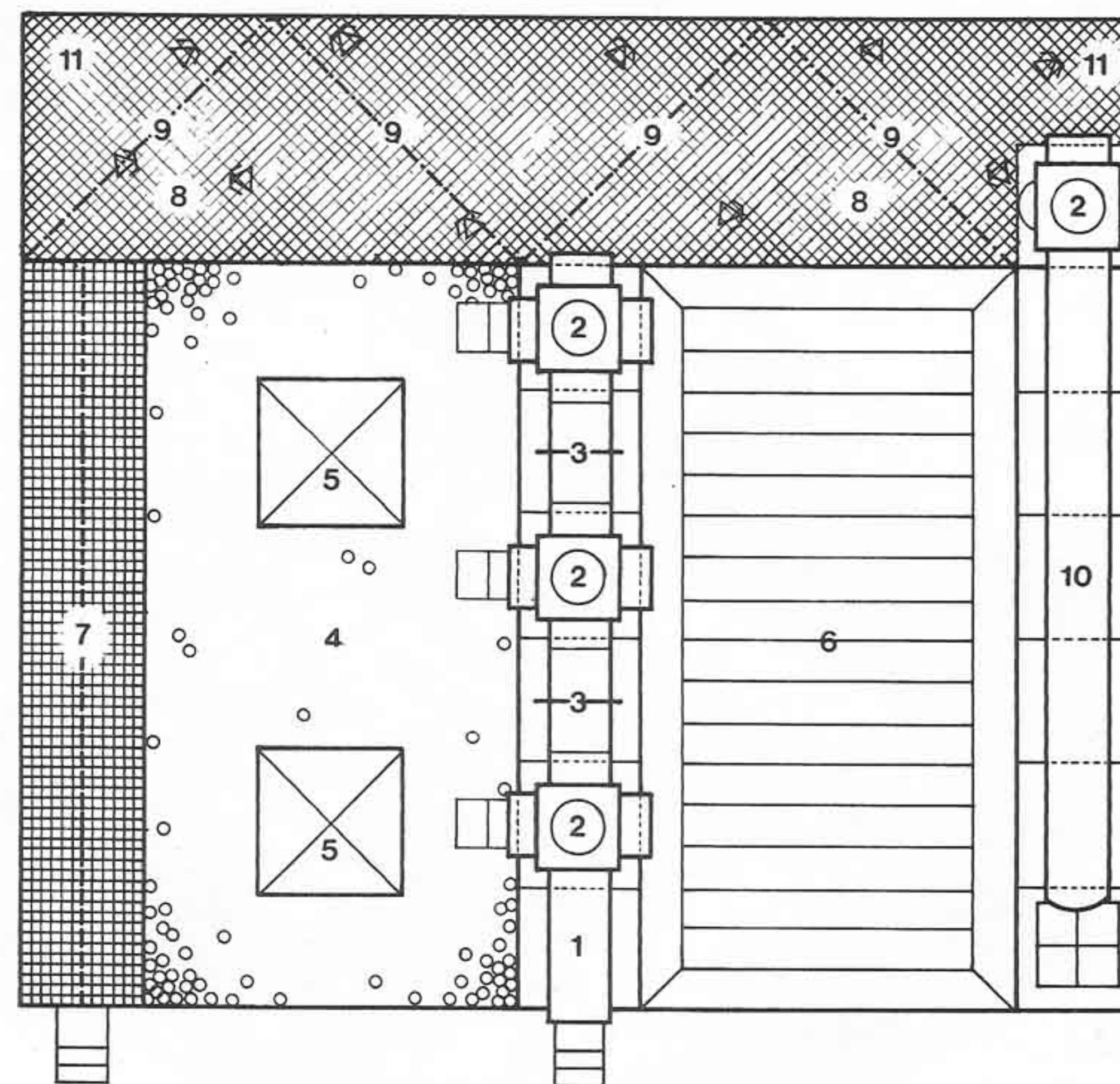

Plain View

Size 48' x 54'
Capacity: 225

KEY:

- 1 - Entry Tube
- 2 - Junction Box
- 3 - Web Crawl
- 4 - 18' x 36' Ball Bath
- 5 - King of the Mountain
- 6 - 18' x 36' Bounce
- 7 - "V" Rope Climb
- 8 - Cargo Crossing (above)
- 9 - Spider Net
- 10 - Super Slide (34')
- 11 - Turtle Track (below)

ACCESSORIES:

- Ball Target
- Ball Hoop
- Big Ball
- Kaleidoscope
- Periscope
- Talking Tubes

All accessories included

Prices and specifications subject to change without notice.

PLAYPORT

SUPER - PLAY IIITM

SPACE CASTLE

SUPER-PLAY IIITM **SPACE CASTLE**

Size 51' x 51'
Capacity: 180

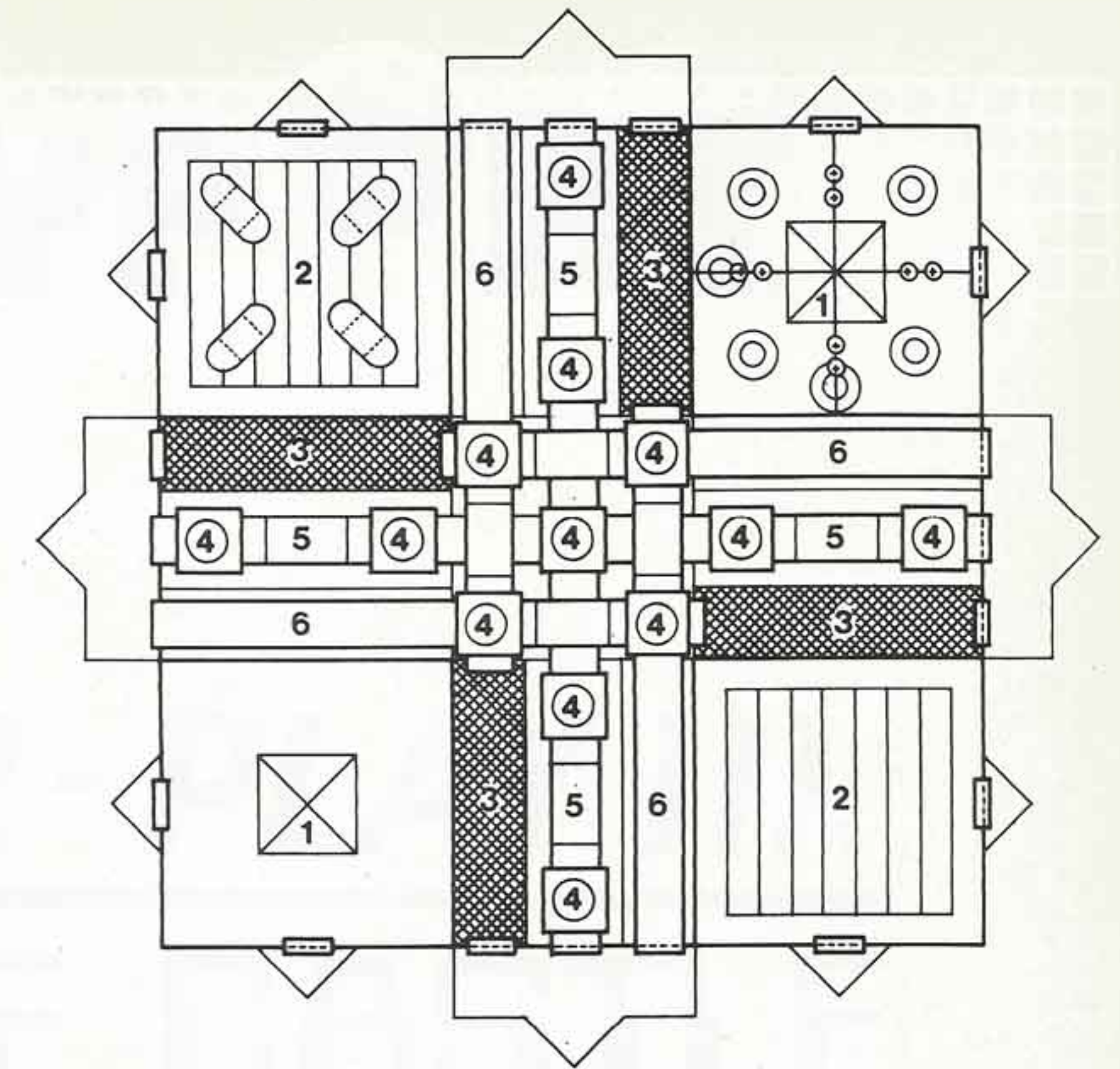
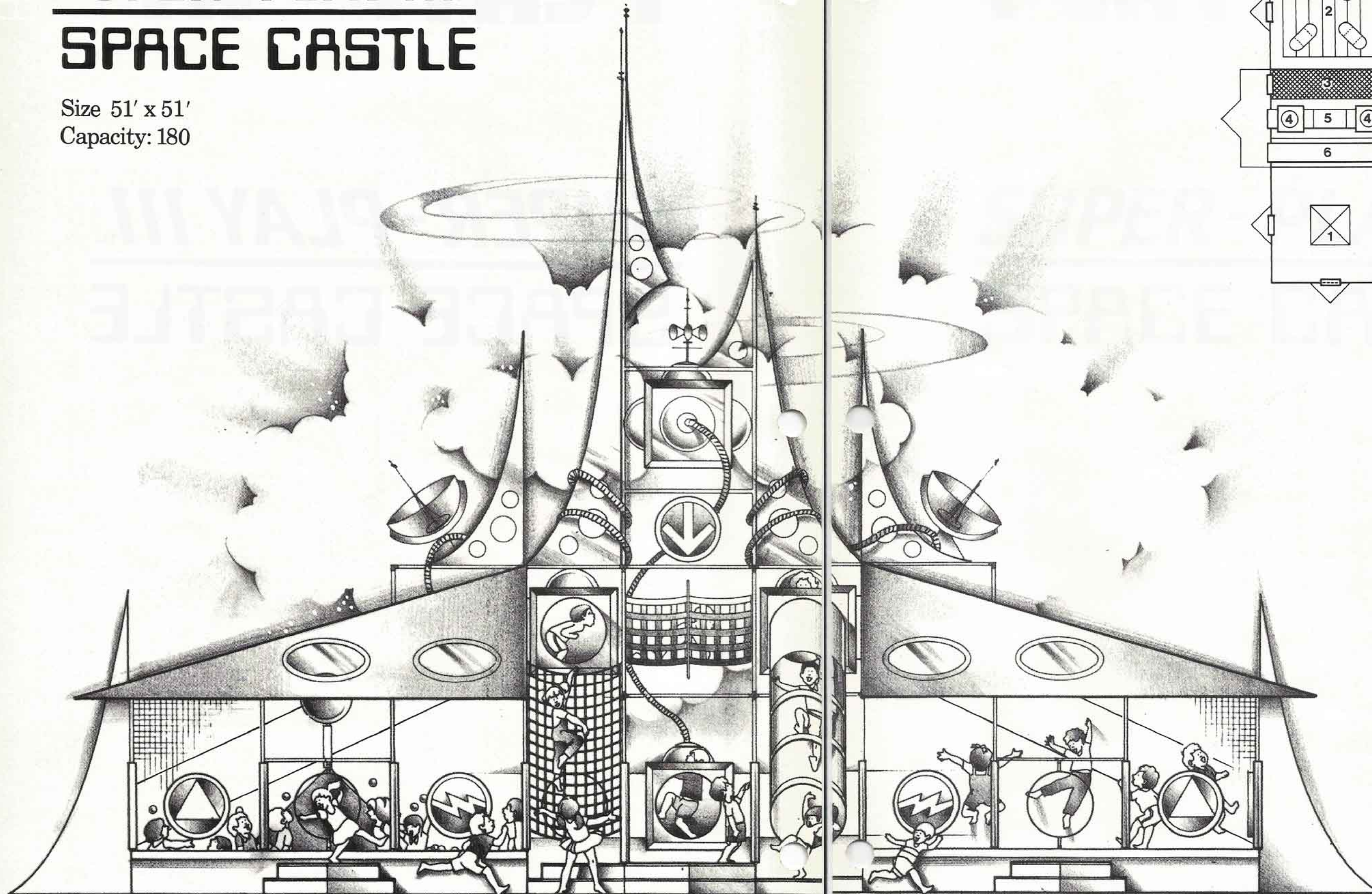

- KEY:**
- 1 - King of the Mountain
 - 2 - Bounce
 - 3 - Cargo Climb
 - 4 - Junction Box
 - 5 - Web Crawl
 - 6 - Super Slide

Prices and specifications subject to change without notice.

Conceptual rendering—exact unit may differ slightly.

© 1986 Pentec Design Inc.

PLAYPORT[®]

WET N' WACKY[™]

WET N' WACKY™

Size 32' x 32'
Capacity 45

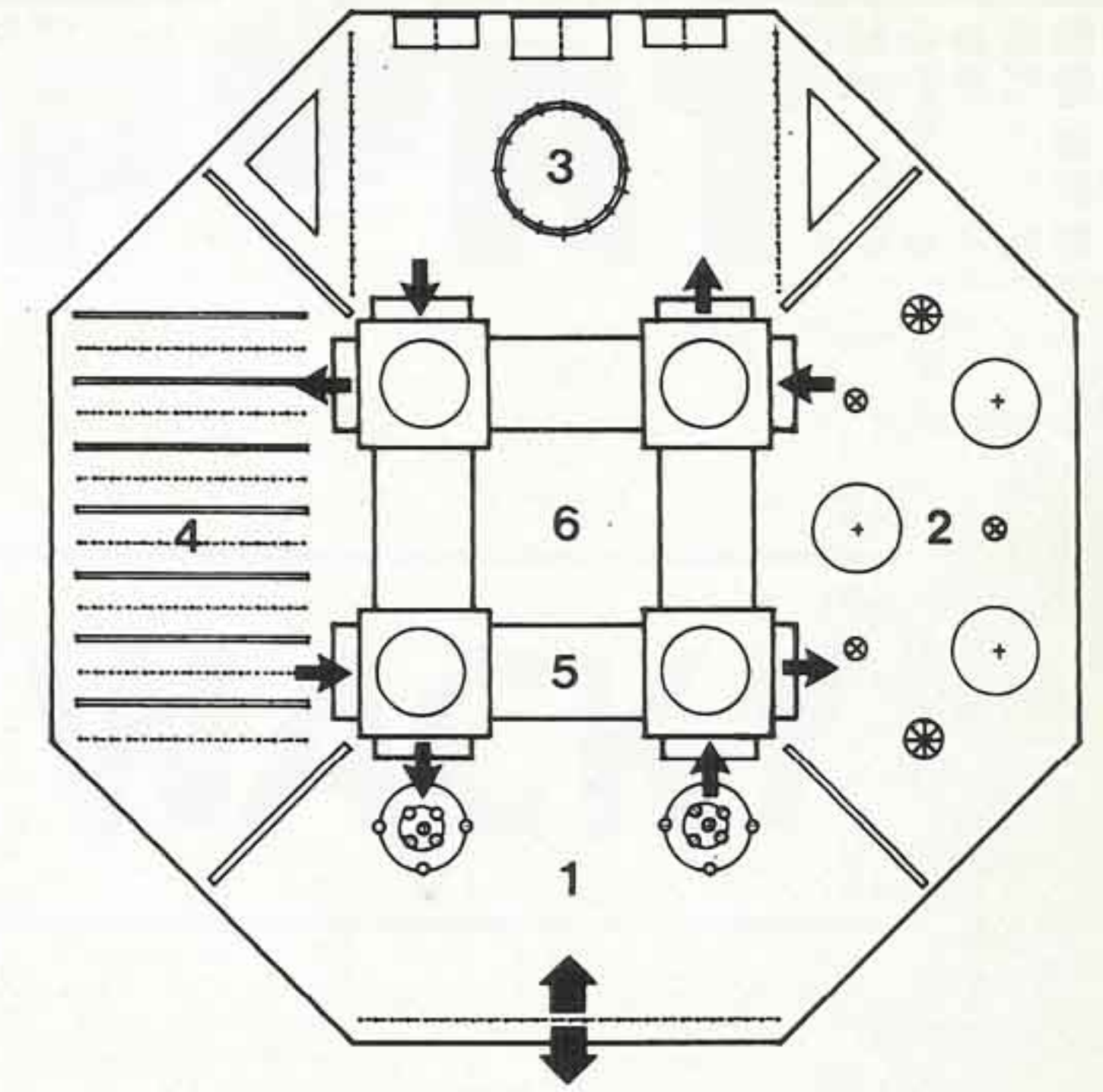

KEY:

- 1 - Entry/ Wild Hoses
- 2 - Rain Room
- 3 - 'Hands-On' Play
- 4 - Vertical Sponges
- 5 - Pipeline Crawl
- 6 - Seascape

Prices and specifications subject to change without notice.

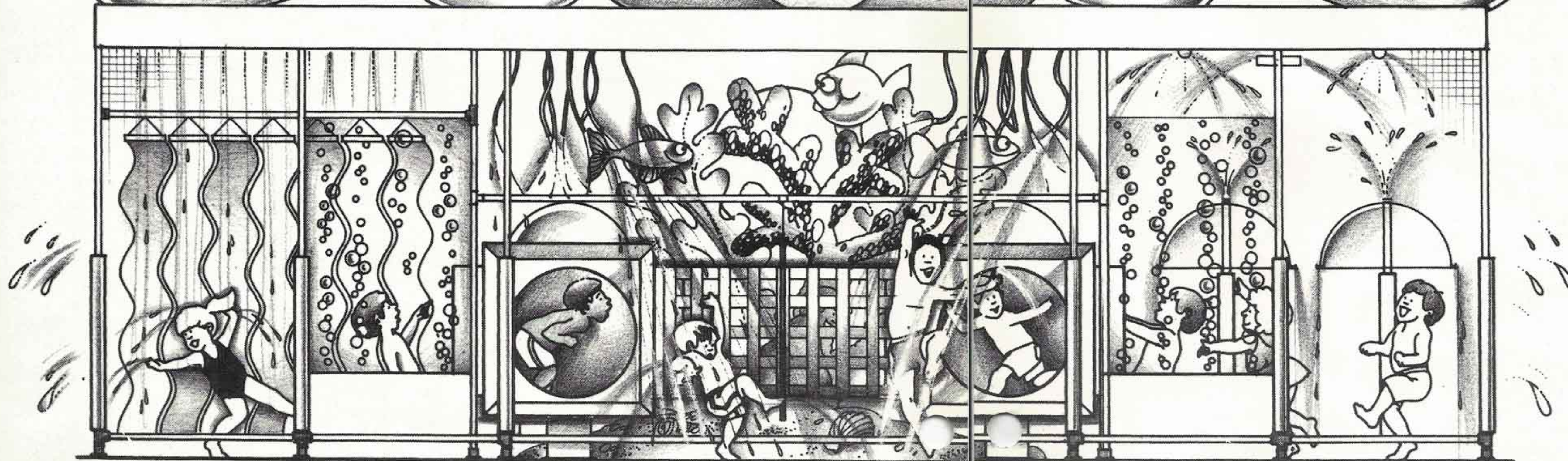

Conceptual rendering—exact unit may differ slightly.

HOT TOT TALKING SIGN™

The **Hot Tot Talking Sign™** is designed for use as an advertising and/or entertainment device. The lovable, humorous looking character attracts attention, draws a crowd and holds its audience when it delivers its message — **YOUR message.**

The **Hot Tot Talking Sign™** is available in 5 versions (please see below for details). In all versions, the character's **mouth movement** is **automatically** synchronized with its talking and the talking **volume is adjustable.** All versions are **warranted** for 6 months.

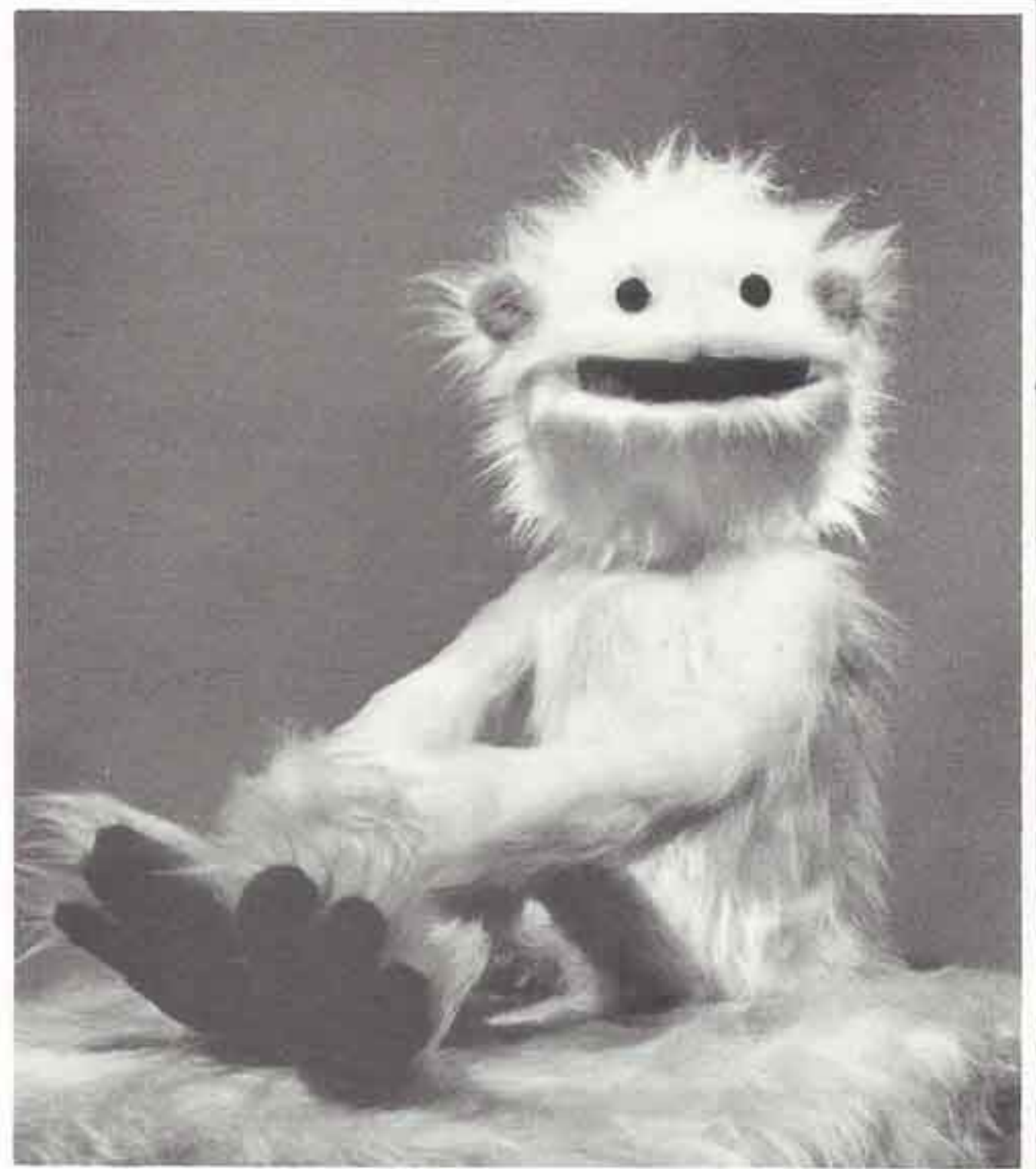

VERSION 1:

Sonar activated cassette deck delivers the message you have recorded (movement within sonar's range starts cassette deck).

Message length can vary from 10 seconds on up.

Adjustable sonar sensitivity and range.

Adjustable timer varies the length of pause between possible triggerings of the sonar and message deliveries.

Best for situations requiring completely automatic operation with noncontinuous play. AC operation.

Approx. 24" tall (plus 20" for legs) x 10½" x 10½" and 19 pounds.

Price: \$1,075.00

VERSION 2:

Cassette deck (automatic reversing) only (same unit as Version 1 but without sonar). Messages may be any length.

Best for situations requiring completely automatic operation and continuous play.

AC operation.

Approx. 24" tall (plus 20" for legs) x 10½" x 10½" and 17 pounds.

Price: \$875.00

VERSION 3:

Live talking only; operator wears a wireless microphone concealed on his/her body. Best for situations requiring constantly changing messages, spontaneous messages and/or conversation between the **Hot Tot Talking Sign™** and its audience.

Battery operated; 1 rechargeable gel-cell battery and 1 charger included.

Approx. 27½" tall (plus 20" for legs) x 7½" x 7½" and 18 pounds.

Price: \$1,175.00

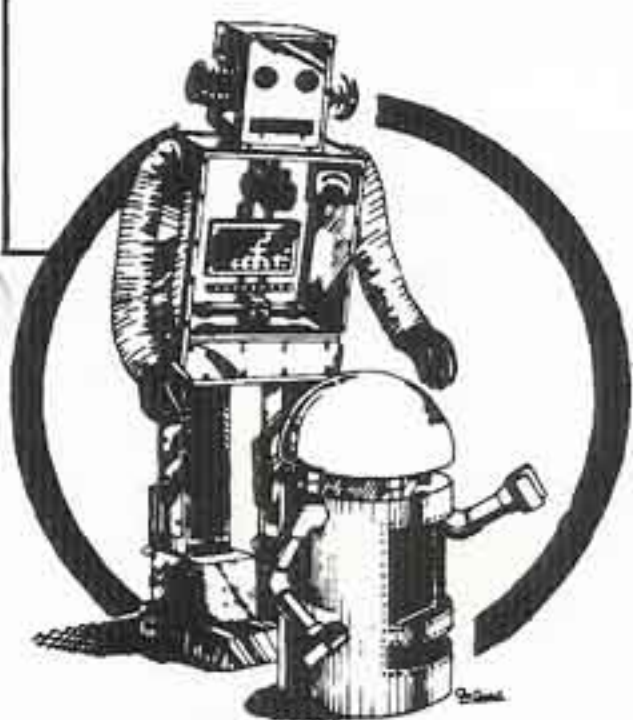

HOT TOT TALKING SIGN™

THE ROBOT FACTORY

P.O. BOX 112 • CASCADE, COLORADO 80809 • (303) 687-6208 • (303) 687-6244
TELEX 4725021

VERSION 4:

Same unit as Version 3 but with 2-way communication. The operator hears what people in the audience are saying by means of a small headset and talks into an attached microphone.

Best for situations in which the operator must be too far away from the audience to hear what is being said.

Battery operated; 1 rechargeable gel-cell battery and 1 charger included.

Approx. 27½" tall (plus 20" for legs) x 7½" x 7½" and 18 pounds.

Price: \$1,375.00

VERSION 5 - THE TWINS:

Same as Version 2 but with 2 characters who talk to each other. Character 1 is recorded on the right channel and character 2 is recorded on the left channel.

Character 1 may also be used by itself as a Version 2 unit.

Messages may be any length.

Best for situations requiring completely automatic operation and continuous play.

Excellent for situations requiring a long message as the message may be turned into a conversation between the 2 characters or into a question and answer session.

AC operation.

Each character approx. 24" tall (plus 20" for legs) X 10½" X 10½"; character 1 approx. 17 lbs. and character 2 approx. 6 lbs.

Price: \$1,775.00

ALSO AVAILABLE: custom traveling case for \$185.00



(chair not included)

HOT TOT TALKING SIGN™

Whatever your message (and it can be anything), it will be listened to when it's delivered by a **Hot Tot Talking Sign™**.

Everyone, from toddlers to senior citizens, loves the **Hot Tot Talking Sign™**.

The **Hot Tot Talking Sign™** will be the most versatile, economical and easy to manage employee you'll ever have.

The
NEW
FF40

ANNOUNCING

An Explosion of Electrifying Light!

Publicize your presence 2 miles from the mid-way! This powerful fluorescent lighting system for amusement rides can create dynamic strobe-like effects—flashing, scrolling, running, and chasing—all complete with speed control and reverse sequence. A total of 64 different programs.

Quality construction and durability are built into every system. Standard bi

pin rapid start fluorescent tubes, optical isolation and fused outputs insure years of outstanding performance.

Incandescent systems are nice, but the FF40 is spectacular. This new system makes standard fluorescent tubes on amusement rides look like gas station lighting. Detonate the mid-way fever with a flashing fluorescent light system from Sellner Manufacturing.

Call Toll Free 1-800/533-0390

or
(507) 334-5584

Sellner

MANUFACTURING COMPANY, Inc.
P.O. Box 8 / Faribault, MN 55021

Rope Lighting



FARRALANE Rope Lights are flexible 16' long plastic tubes containing 84 lamps individually wired to four separate channels. When a Rope Light is connected to a 4 channel chaser/sequencer unit the lights appear to follow each other along the tubes, producing some of the most spectacular visual effects. Up to 20 individual Ropes can be interconnected for an infinite variety of applications. Power consumption 18 watts/channel @ 120 vac.



RC404

- 4 channel manual chaser
- Light chase
- Dark chase
- All lights on
- Alternate chase (D&L Auto)



SAS401A

- 4 channel manual/audio chaser
- Forward/reverse
- Audio sensitivity control



**STARBURST
CONTROLLER C5**

- 4 channel/500W-channel
- 16 patterns in memory with starburst and pinwheel
- Audio and manual control
- Sound activated with built in microphone, as well.

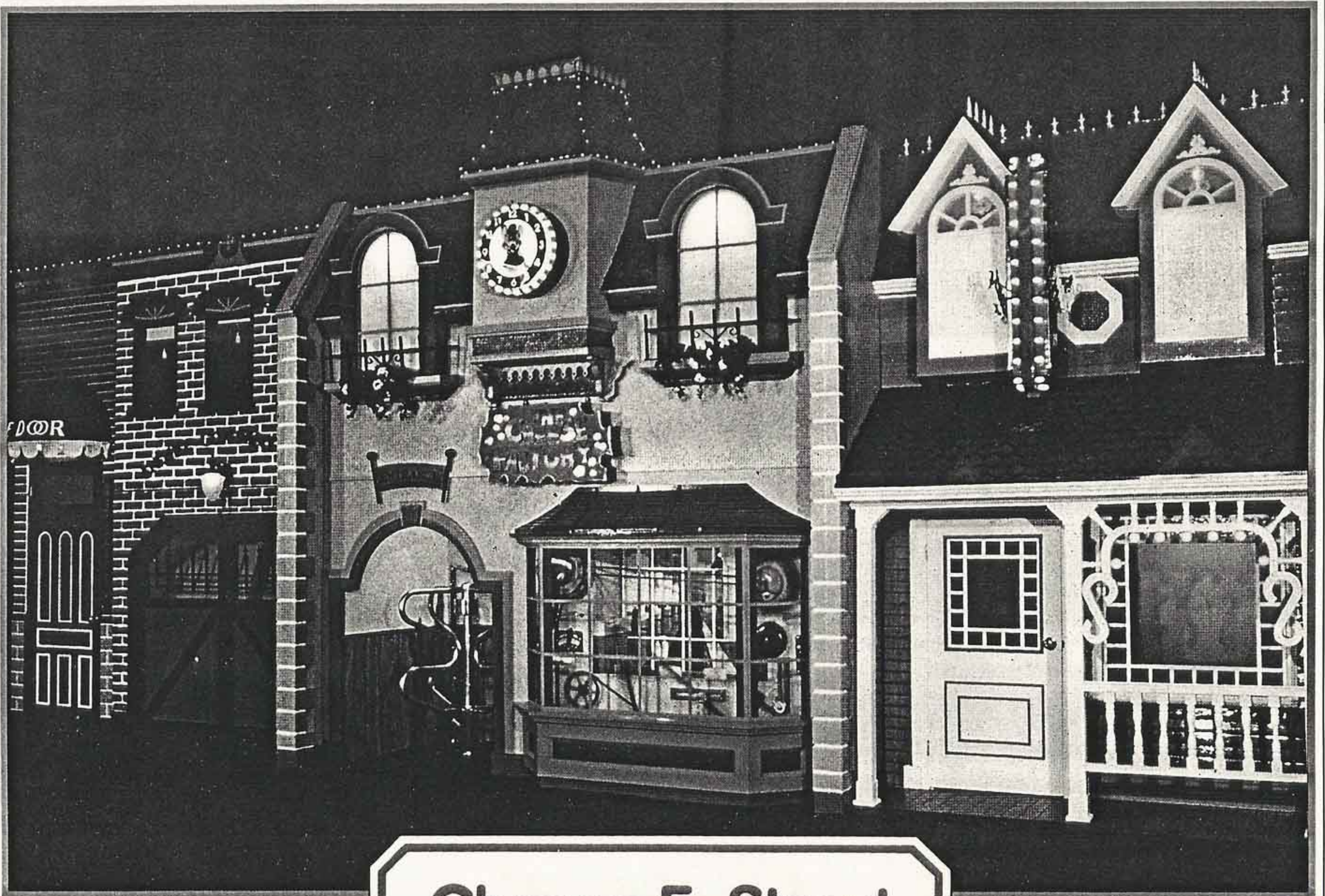

Cheese E. Street

SHOWBIZ PIZZA TIME, INC.
ATTRACTION DEVELOPMENT PROGRAM
(Field-used Research Binder)

Date of Origin: 1987
Archived: 3-14-13
Submission by VegaNova / P. Linden
Version 1.0

The documents contained herein are for educational use only.
Please do not replicate, redistribute, or make any unauthorized
printings. All intellectual property including characters,
artwork, photography, and slogans are trademark and/or
copyright their respective owners.

