

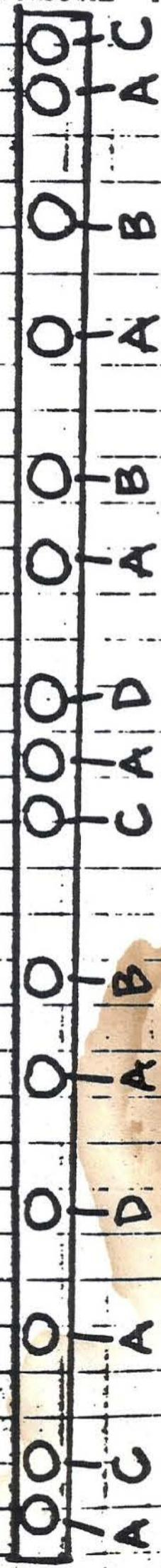

# STAGE LIGHTING AG.1

30-0009-01

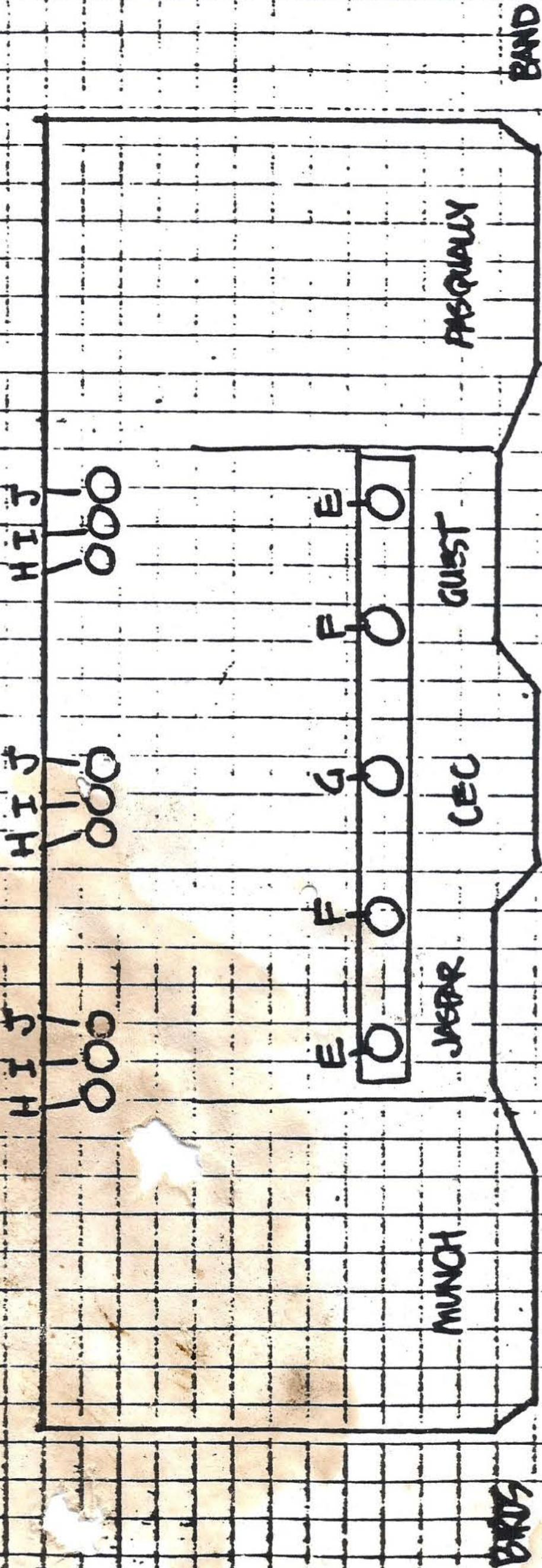

Front

SEE KEY FIG. 2

KEY FIG. 2

30-0009-01

FIXTURES

L704MB Regular

L201MB Filter holder

Goosenecks

150W PAR38 SPOT

150W PAR38 FLOOD

BULBS

Dichromatic Red

Dichromatic Yellow

Dichromatic Blue

FILTERS

L211 Med. Pink

L212 Red

L220 Blue

L231 Amber

L241 Med. Green

| A | B | C | D | E | F | G | H | I | J |
|---|---|---|---|---|---|---|---|---|---|
| * | * | * | * | * | * | * |   |   |   |
|   | * | * | * | * | * | * |   |   |   |
|   |   |   |   |   |   |   | * | * | * |
| * | * | * | * |   |   |   |   |   |   |
|   |   |   |   | * | * | * |   |   |   |
|   |   |   |   |   |   |   | * |   |   |
|   |   |   |   |   |   |   |   | * |   |
|   |   | * |   |   |   |   |   |   |   |
|   |   | * | * |   |   |   |   |   |   |
|   |   |   | * |   |   |   |   |   |   |
|   |   |   |   | * |   |   |   |   |   |
|   |   |   |   |   | * |   |   |   |   |

PARTS LIST FIG. 3

30-0009-01



FIXTURES

- 1. 20 HALO L740 MB fixtures
- 2. 13 HALO L201 MB filter holders
- 3. 9 Gooseneck fixtures

2  
30-0009

BULBS

- 4. 15 150W PAR 38 Spots
- 5. 5 150W PAR 38 Floods
- 6. 3 Sylvania Dichromatic Red Spots
- 7. 3 Sylvania Dichromatic Yellow Spots
- 8. 3 Sylvania Dichromatic Blue Spots

FILTERS

- 9. 3 HALO L211 Pink Filters
- 10. 5 HALO L212 Red Filters
- 11. 2 HALO L220 Blue Filters
- 12. 2 HALO L231 Amber Filters
- 13. 1 HALO L241 Green Filter

# NEW FILTER APPLICATIONS Pg. 4

This chart shows the existing filters & the location & type of the filters to be installed.

## DI-CHROMICS

RED  
YELLOW  
AMBER  
BLUE

RED  
YELLOW  
AMBER  
BLUE

RED  
YELLOW  
AMBER  
BLUE

NO CHANGE

## FLOODS

RED  
AMBER  
BLUE

BLUE

BLUE

AMBER

GREEN  
AMBER  
RED



## SPOTS

BLUE  
RED  
AMBER  
BLUE

AMBER

RED

BLUE

AMBER

RED

BLUE

AMBER

BLUE

PINK  
↑

PINK  
↑

PINK  
↑

RED  
↑

Front

NEW

LOUNGE  
LIGHT  
STANDARD

5 COMPUTER  
CONTROLLED  
LIGHTS

CEILING  
MOUNTED

- (A) CLEAR FLOOD
- (B) CLEAR FLOOD
- (C) AMBER SPOT
- (D) RED SPOT
- (E) BLUE SPOT
- (F) RED SPOT
- (G) CLEAR SPOT

030-0012-01  
THE KING  
INST. INST.

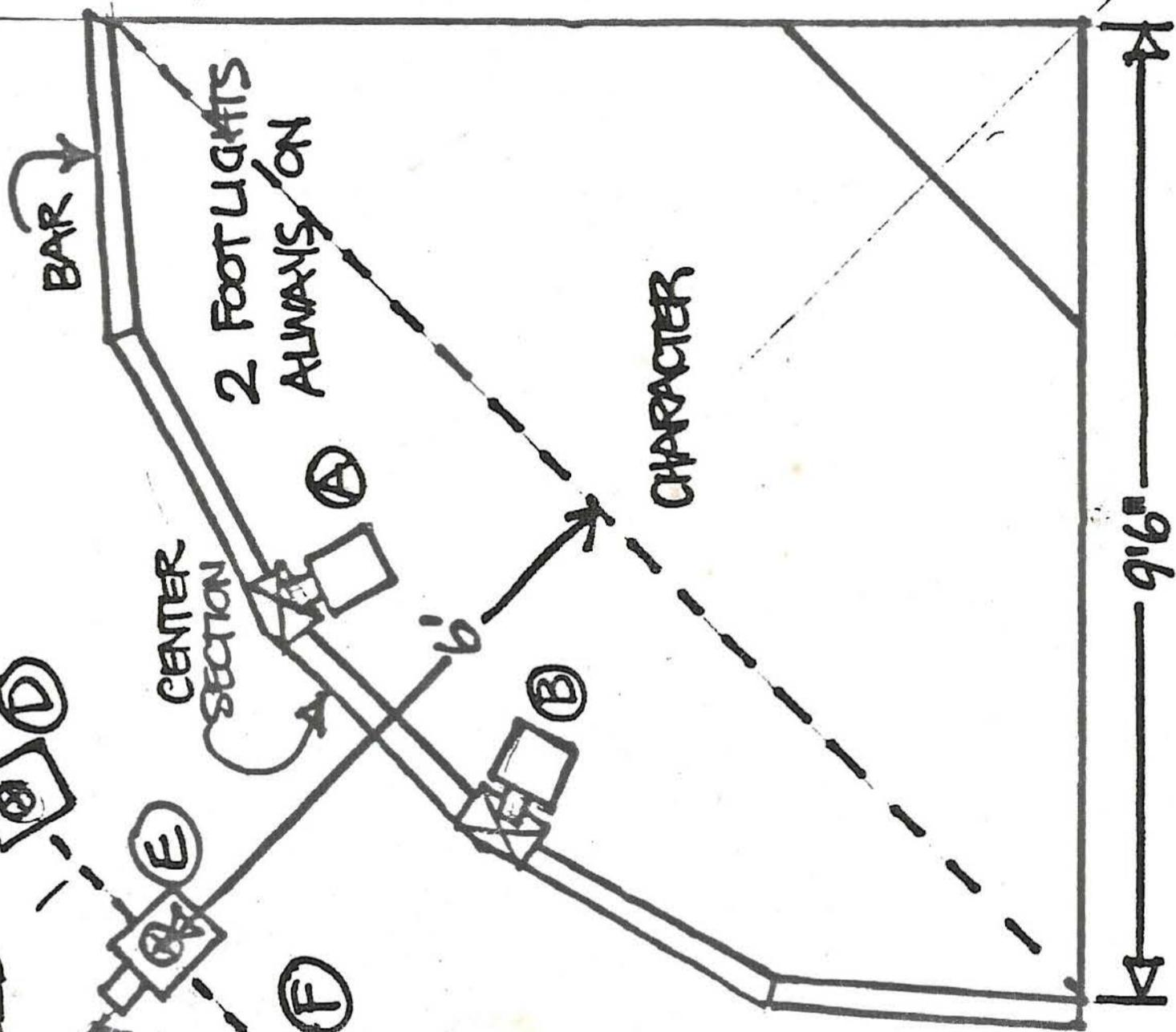

FOOTLIGHT DETAIL

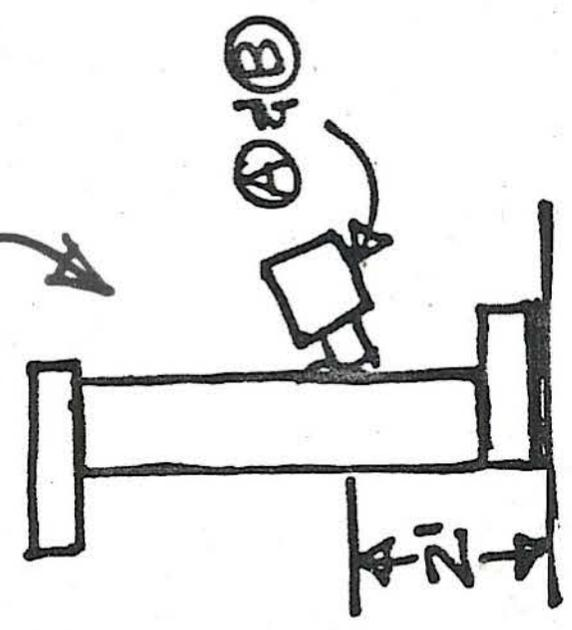

BAR FROM SIDE  
(CENTER SECTION)

FIXTURES: HALO L704 MB (or EQUIV.)  
LAMPS: 150 W PAR 38

| LIGHT | HALO<br>FIXTURE | OR | CAPRI<br>FIXTURE* | BULB           | COLOR |
|-------|-----------------|----|-------------------|----------------|-------|
| A     | L704MB          |    | CT140 Black       | 75W Par 38 FL  | Clear |
| B     | L704MB          |    | CT140 Black       | 75W Par 38 FL  | Clear |
| C     | L704MB          |    | CT140 Black       | 150W Par 38 SP | Amber |
| D     | L704MB          |    | CT140 Black       | 150W Par 38 SP | Red   |
| E     | L704MB          |    | CT140 Black       | 150W Par 38 SP | Blue  |
| F     | L704MB          |    | CT140 Black       | 150W Par 38 SP | Red   |
| G     | L704MB          |    | CT140 Black       | 150W Par 38 SP | Clear |

\* On weighted Trac Base #C23

# FIG 8. LOUNGE

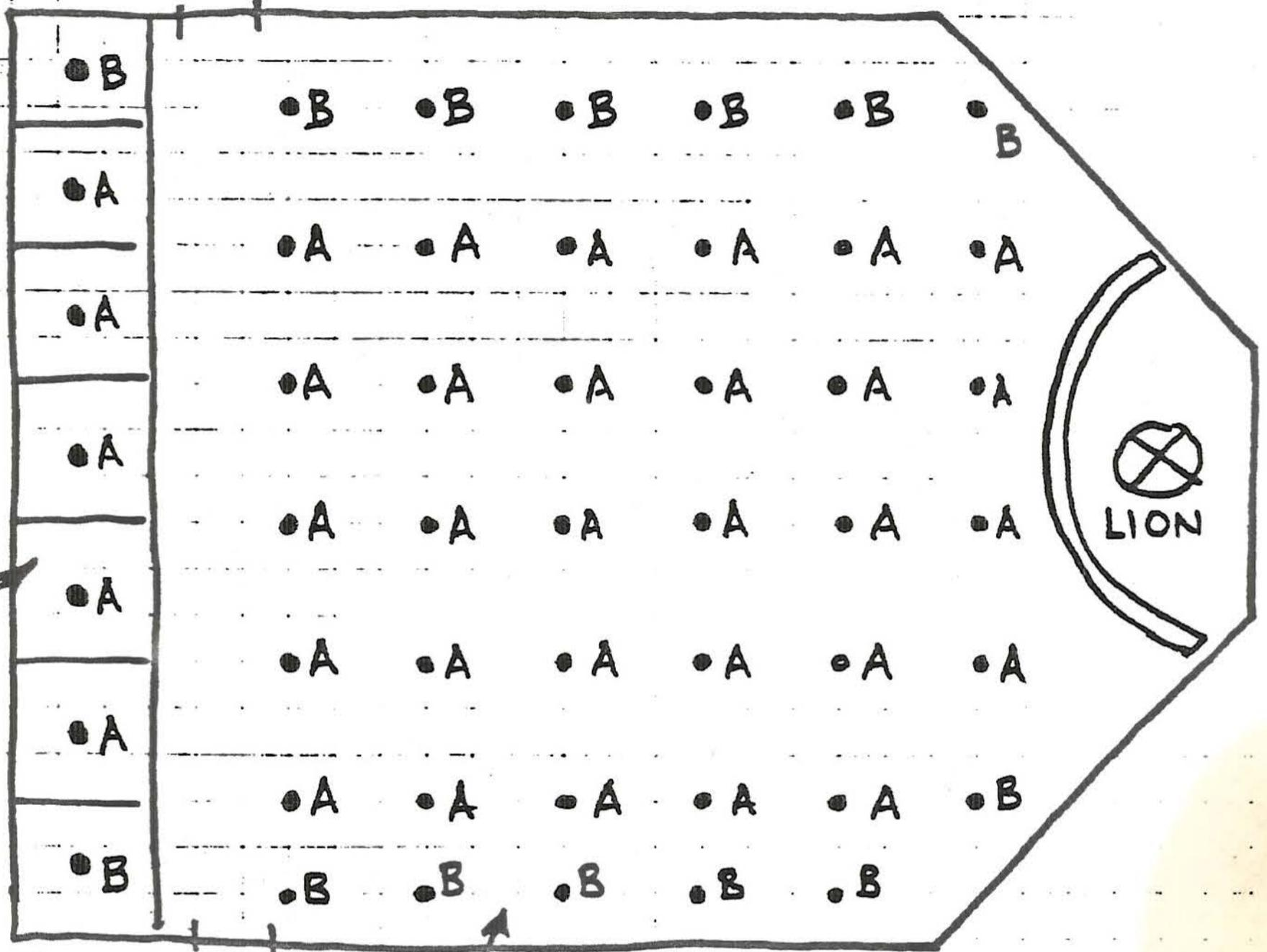

BOOTHS:  
 CAPRI  
 P751  
 CANS  
 75N R30 FL  
 BULBS.

LOUNGE  
 CEILING:  
 CAPRI AISOI FIXTURES  
 ISOW P38 FL BULBS.

B = BLUE  
 A = AMBER

Lounge (Beagles, Lion).

The Lounge has these fixtures:

Ceiling: Capri A1501M with 150W P38 FL bulbs.

Booths: Capri PC751 cans with 75W R30 FL bulbs.

The lounge requires amber and blue lights.

The two outer strips of lights (closest to the walls) should be blue, the remainder should be amber. See Figure B.

NOTE: Amber is not yellow!

# SPEAKER PLACEMENT

THIS INSTALLATION USES 2 JBL 4311 (OR 4313) SPEAKERS- CHAIN HUNG FROM THE CEILING OR MOUNTED ON THE WALL USING "L" BRACKETS.

THEY SHOULD BE ORIENTED SLIGHTLY IN TOWARD DRAPES CENTER (5° EACH) AND SLIGHTLY DOWN TOWARD THE AUDIENCE (10° EACH).

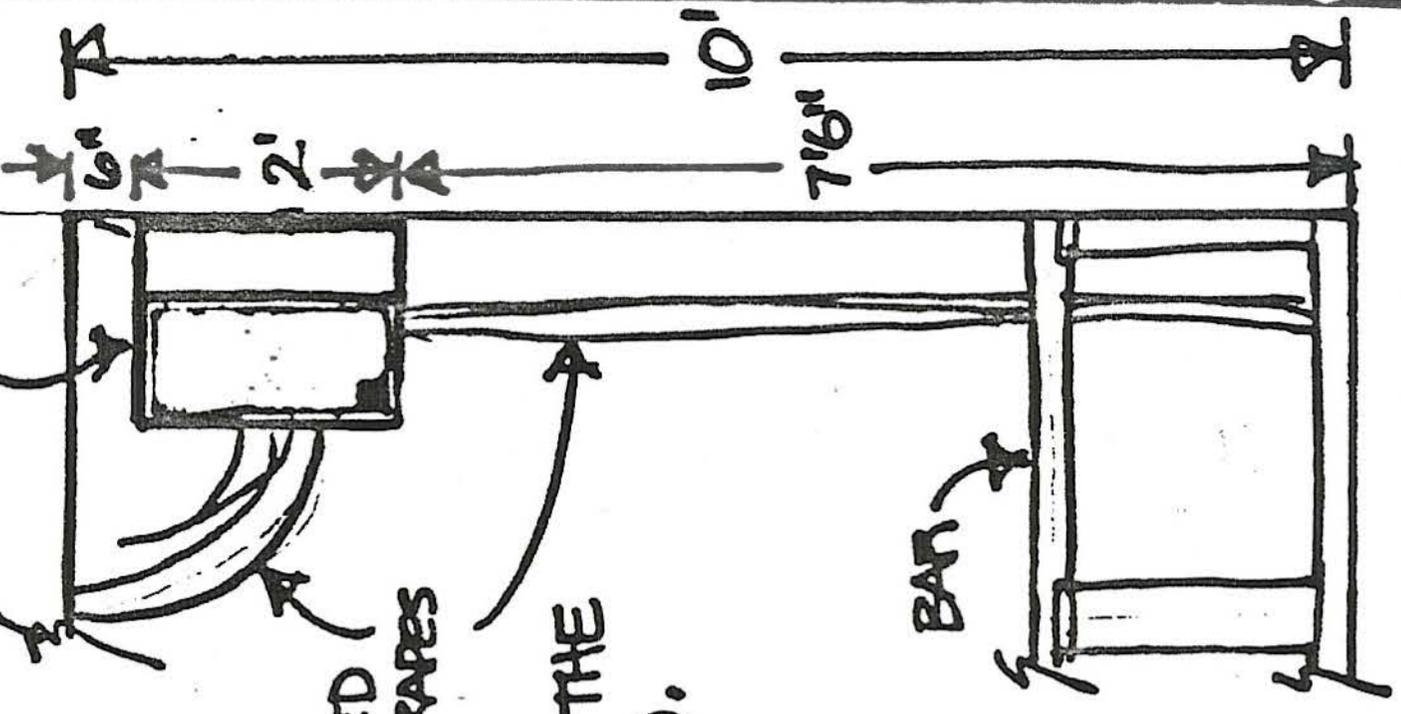
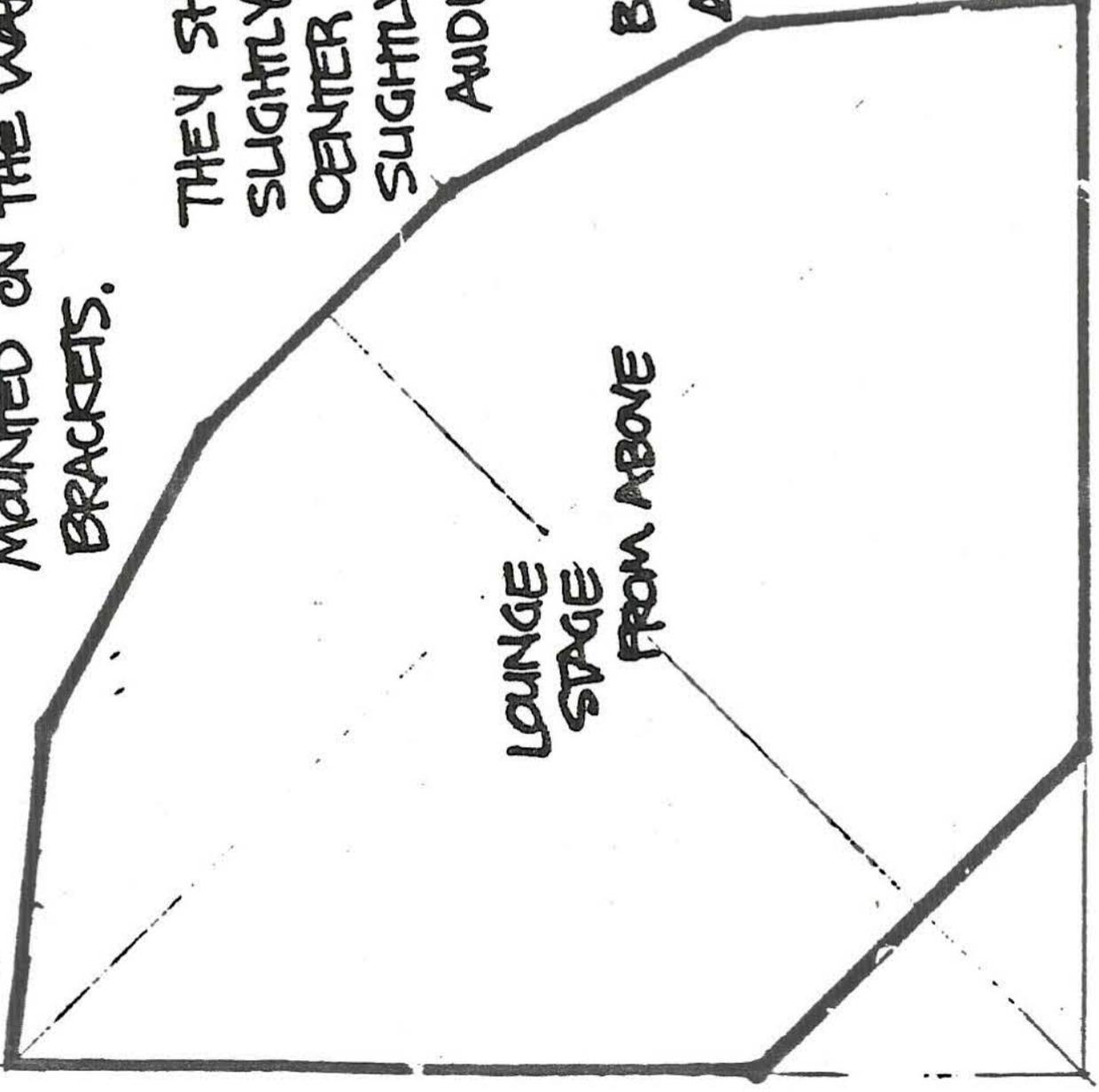
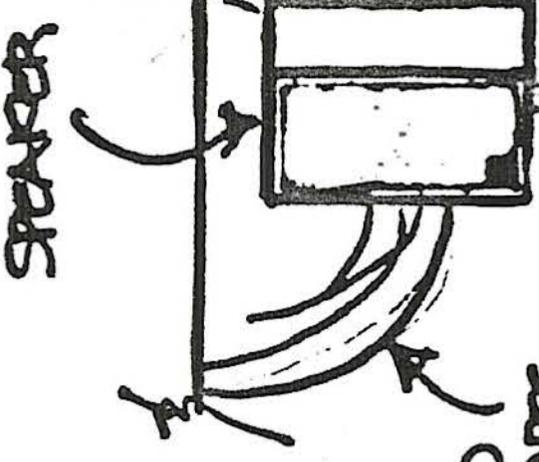
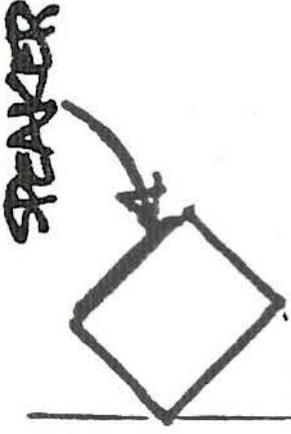

LOOKING ALONG THE WALL FROM FRONT

# LOUNGE STAGE DIMENSIONS

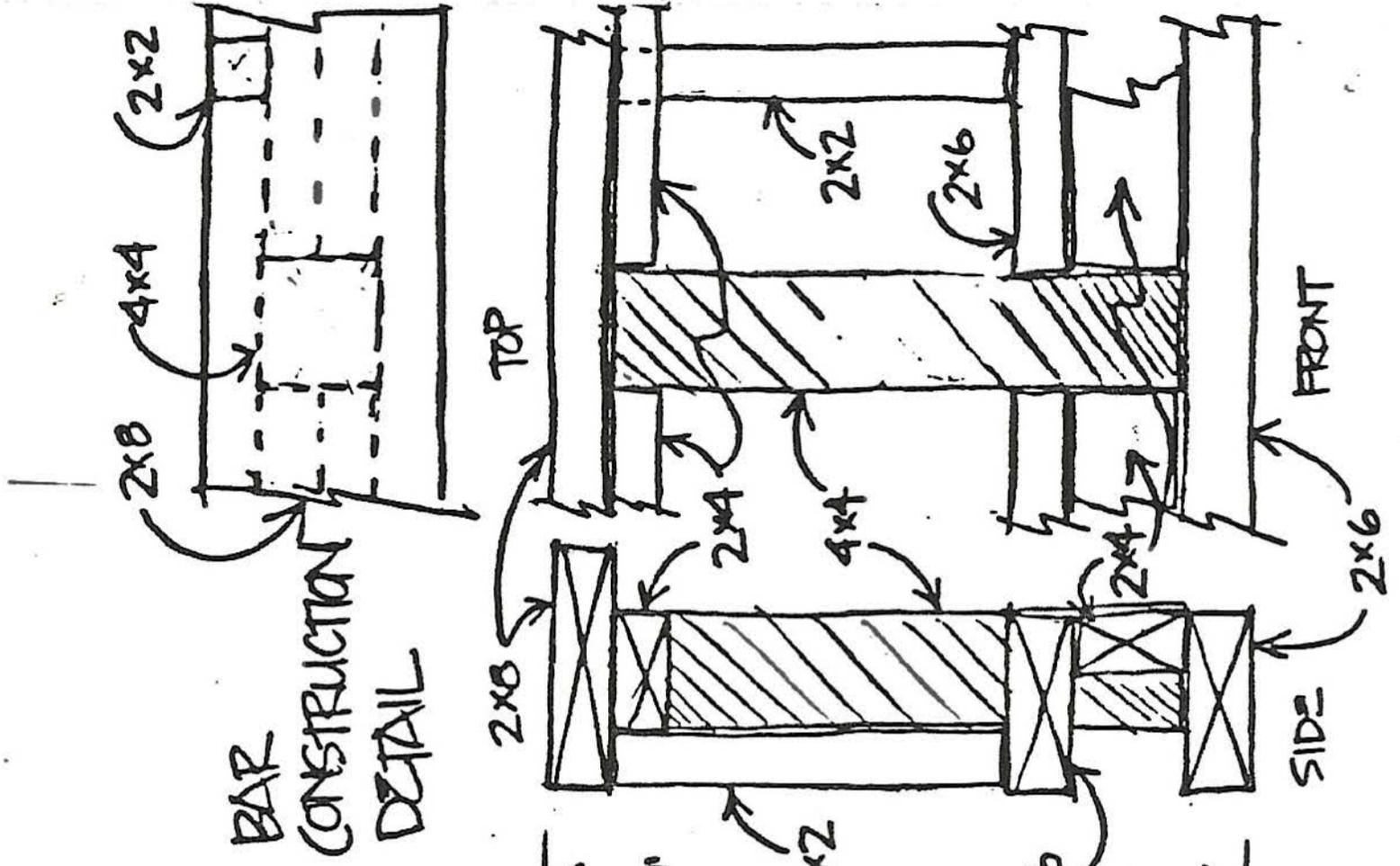
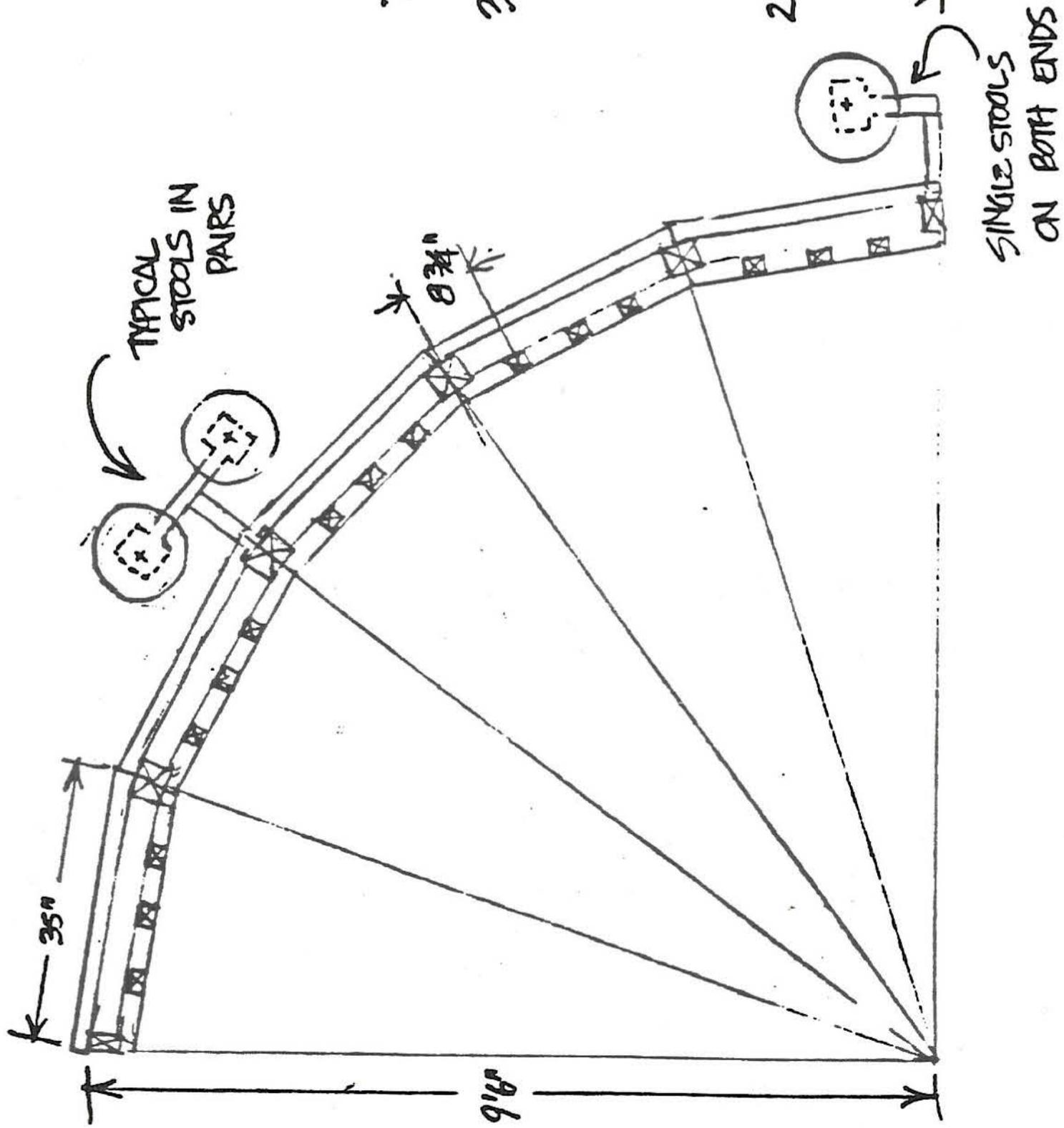



LOUNGE VALANCE

2' HIGH X 15' WIDE

BUNTED & GATHERED, FIREPROOF

MEDIUM BLUE VELOUR

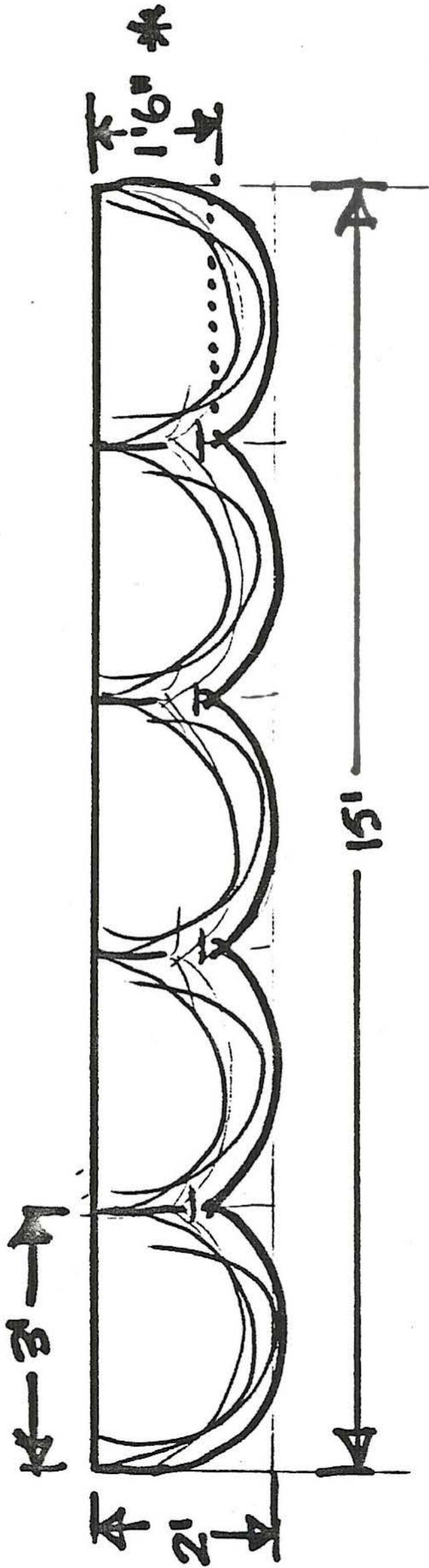

\* THIS DIMENSION IS  
OPEN, PER THE ACTUAL  
STYLE OF THE GATHERS.  
IT SHOULD BE BETWEEN  
1' 2" & 1' 8".



CHARACTER  
PLACEMENT  
THE KING

THE LION'S PLATFORM IS PLACED ON THE FLOOR BEHIND THE BAR IN THE LOUNGE. IT GOES 3' FORWARD OF THE CORNER, CENTERED. THATS ONE FOOT FORWARD OF THE CURTAINS. AT THE FRONT EDGE, PLATFORM CORNERS ARE 5' OUT FROM EITHER WALL (AT 45°) AT 9'6" DOWN THE WALL; 4' FROM THE CURTAIN. THE PLATFORM IS SLIGHTLY MORE THAN 3' WIDE.

THE LION IS BOLTED INTO THE FLOOR.

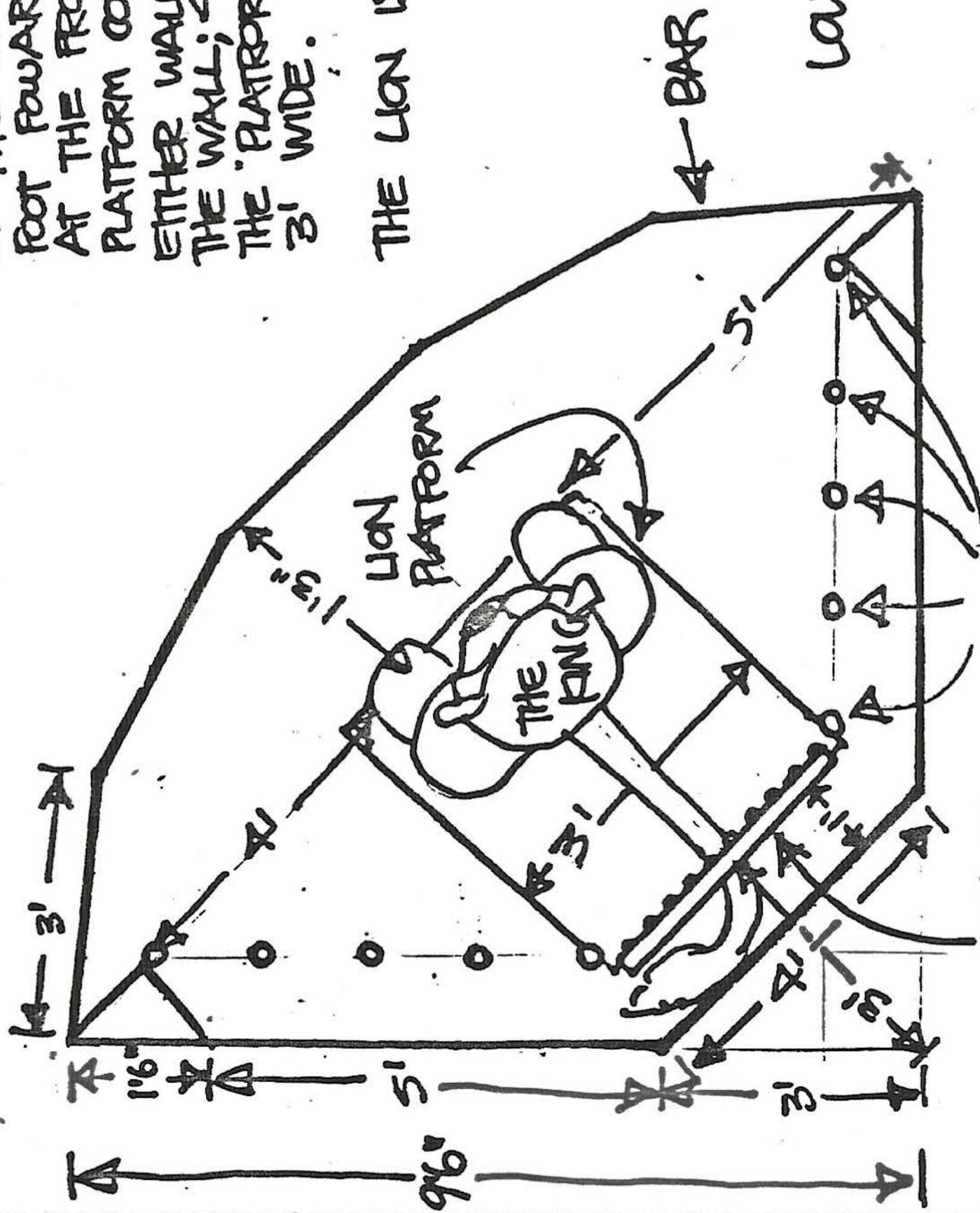

LOUNGE STAGE FROM ABOVE

FOAM CORE SIGN WITH MINI-LIGHT STRING

BEN

SET INSTALLATION

—— BACKGROUND CURTAIN

—— VALANCE CURTAIN

FOAM CORE SIGN WITH MINI-LIGHTS

TWO STRING LIGHTS (5 EACH SIDE)

FLOOR COVER

- (B)
- (C)
- (D)
- (E)

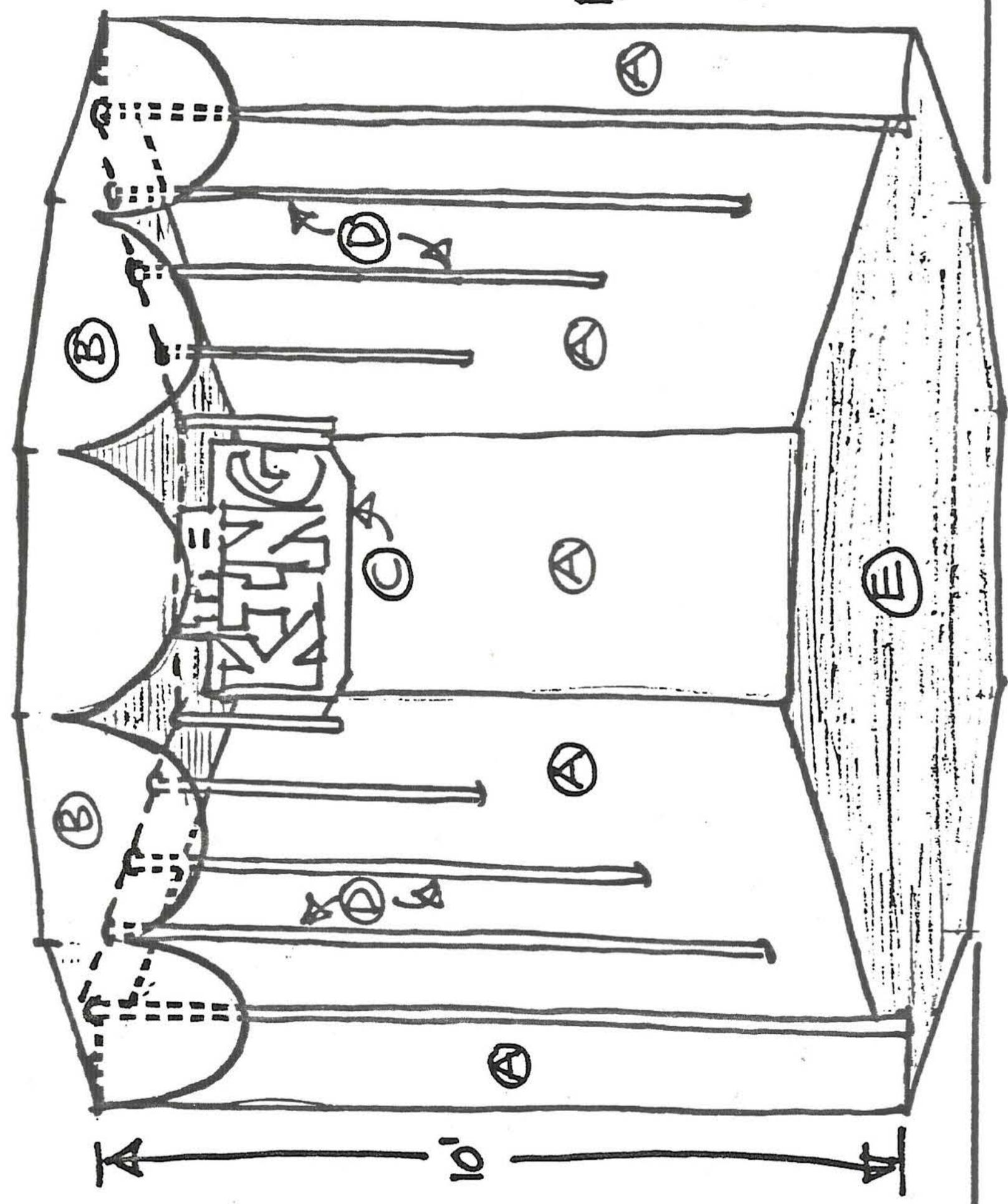

NOTE: BAR  
NOT SHOWN

# SET INSTALLATION

## THE KING

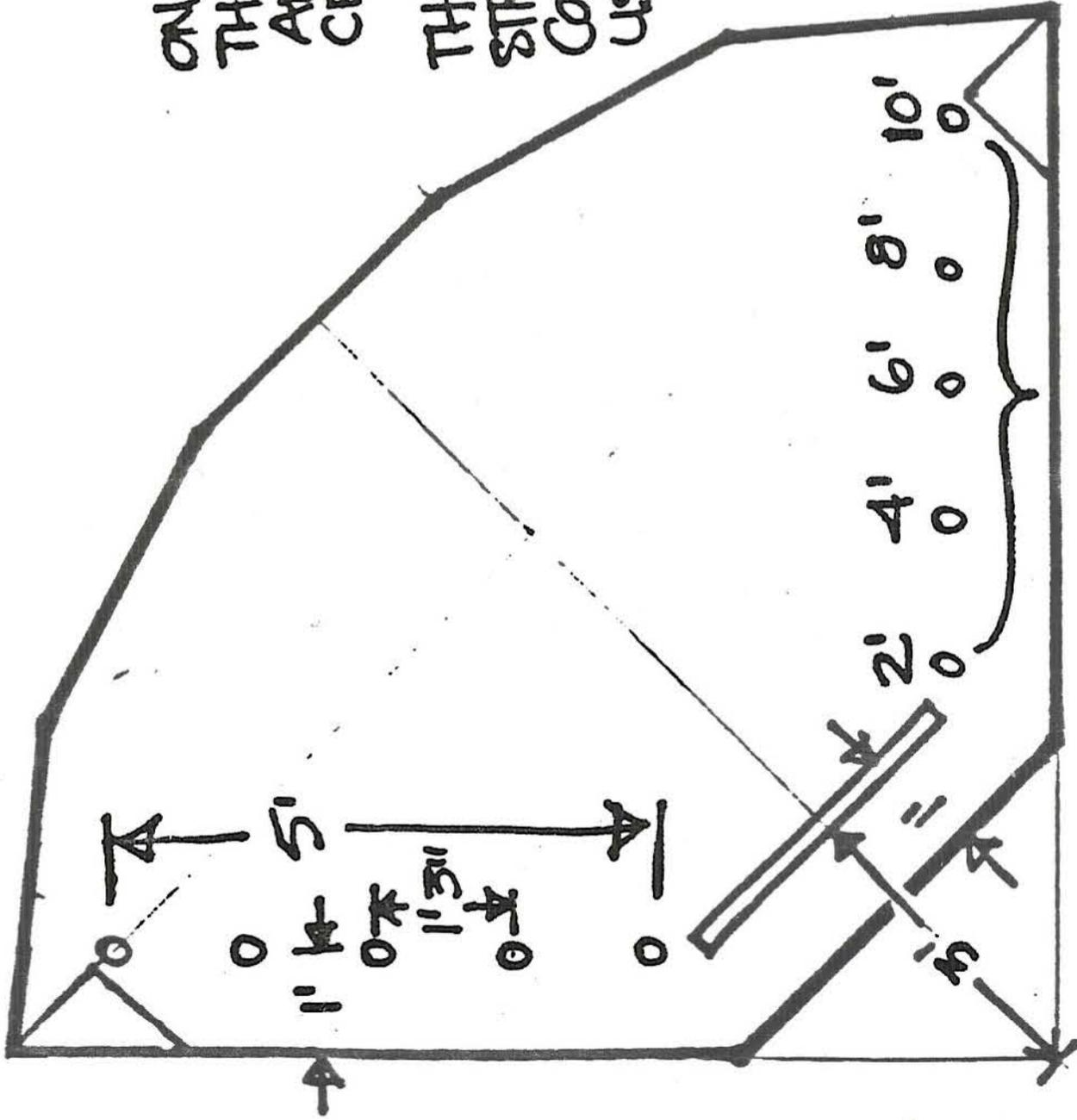

TNDU LIGHTS  
(DIMENSIONS ARE LENGTHS)

REN

THE KING'S SET CONSISTS OF BLUE VELOUR BACKGROUND CURTAINS AND VALANCE, TNDU STRING LIGHTS, A FOAM CORE SIGN, SET WITH A STRING OF MINI-LIGHTS, AND A FLOOR COVER.

ONCE THE CHARACTER IS INSTALLED THE FLOOR COVER HIDES THE AIR AND CYBER RUNS AS WELL AS THE CEC CARPET.

THE TNDU LIGHTS AND THE MINI LIGHT STRING ARE CONTROLLED BY SPOLS COMMAND IN THE ANIMATION. THEY USE THE OPEN CIRCUIT IN THE 3 AC SWITCHERS THAT CONTROL THE OVERHEAD LIGHTS.

THE LIGHTS AND SIGN ARE HUNG FROM THE T-BAR AND CEILING TILES.

# BACKDROP SIGN

14' 31"

2' 1"

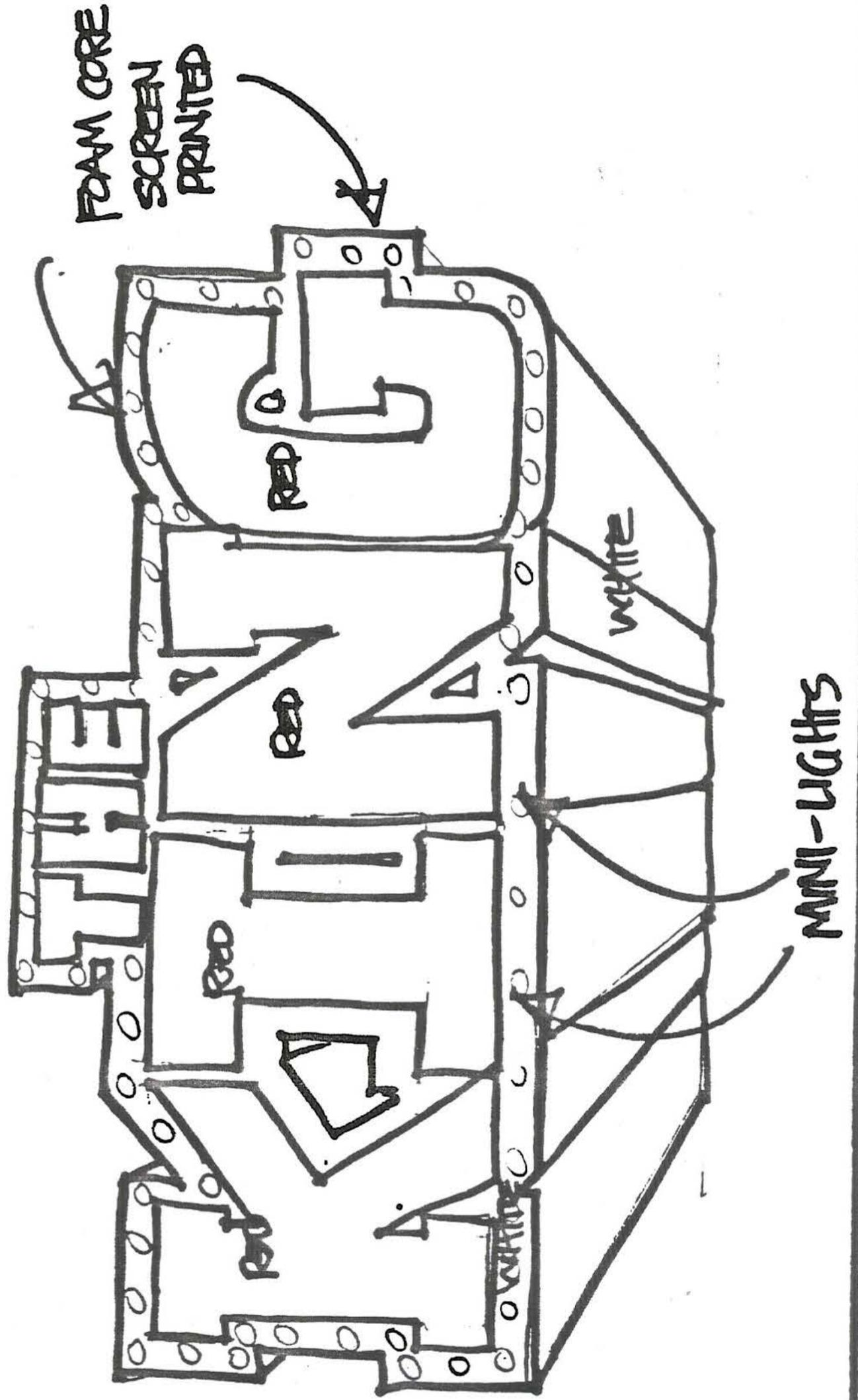

# LION FLOOR COVER

- \* BLACK CARPET
- \* LOW NAP
- \*( WITH OR WITHOUT CUTOUTS )
- \* CHEAP !

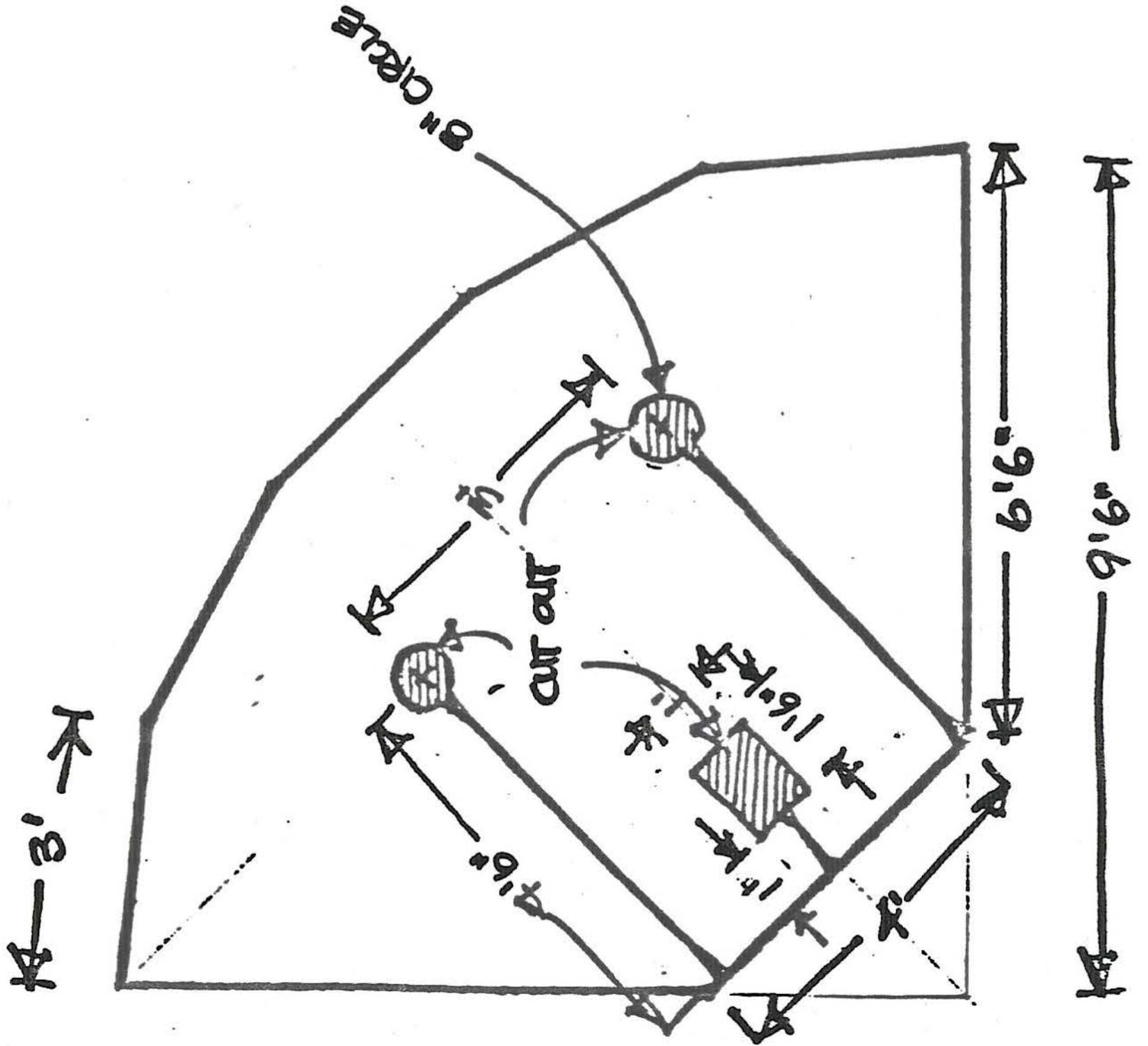

# LIGHT FOCUS

"HOT SPOT"  
AT FACE



"HOT SPOT"  
AT GUITAR

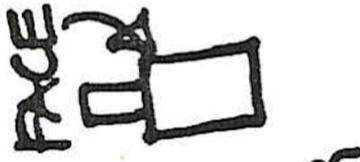
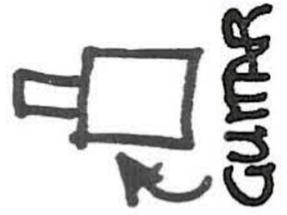
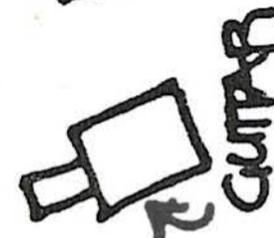
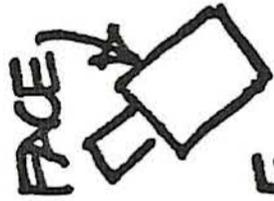

STAGE  
LEFT

GUITAR

GUITAR

STAGE  
RIGHT

IT TAKES TWO PEOPLE TO FOCUS LIGHTS - ONE TO MOVE THE LIGHT AND ONE TO STAND WHERE ITS SHINING TO SEE THE "HOT SPOT" OR THE BRIGHT CENTER OF THE BEAM OF LIGHT FALLING ON THE CORRECT AREA OF THE CHARACTER.

THE OUTSIDE AND CENTER LIGHTS ARE AIMED AT THE LIONS HEAD AND UPPER BODY. THE MIDDLE LIGHTS ARE AIMED AT HIS GUITAR AND MIDDLE SECTION, BUT SHOULD ALSO LIGHT HIS FACE.

THE FOOTLIGHTS, WHICH ARE ALWAYS ON, SHOULD BE AIMED AT THE CHARACTERS UPPER 2/3'S.

# STAGE LIGHTING REVISION

(From the Theatrical Standards Manual, with original memo)

Date of Origin: April 1981

Archived: 12-16-23

Submission by Pikalove

Version 1.0

The documents contained herein are for educational use only. Please do not replicate, redistribute, or make any unauthorized printings. All intellectual property including characters, artwork, photography, and slogans are trademark and/or copyright their respective owners.

